

CHAPTER - 05 HIGHLIGHTS (Summary of Changes)

Revision No. TR05-19 Apr 24/19

TO: HOLDERS OF THE AIRCRAFT MAINTENANCE MANUAL (06-117751)

Pages that have been added or revised are summarized below. Remove and insert the affected pages as listed, and enter the above revision number with issue date into the Record of Revisions sheet.

This Temporary Revision incorporates and supersedes previously released temporary revisions for the chapters listed below.

Do not remove this page. Keep it in place as a record of previous changes.

CH/SE/SU Page Block No.	Description of Change
05-00-00 PgBlk 1	Remove Life Extension Inspection Requirements from AMM. Supersedes 06-117751-TR05-15.
05-10-10 PgBlk 1	Revised Table 1, Secondary Outflow Valve filter replacement to delete 48 month Inspection. Revised Table 1, Passenger Oxygen Mask overhaul interval. Supersedes 06-117751-TR05-16 and 06-117751-TR05-17.
05-20-00 PgBlk 1	Remove Life Extension Inspection Requirements from AMM. Supersedes 06-117751-TR05-15.
05-20-10 PgBlk 1	Replaced floor panel 131 CZ with 131 CZ-A and CZ 131-B due to ADS-B Installation (MB 500-34-030). Added Passenger Door Handle Check. Supersedes 06-117751-TR05-18.
05-20-20 PgBlk 1	Deleted 48-month Secondary Outflow Valve Filter Replacement. Kept 1,200-hour requirement. Replaced floor panel 131 CZ with 131 CZ-A and CZ 131-B due to ADS-B Installation (MB 500-34-030). Supersedes 06-117751-TR05-16 and 06-117751-TR05-18.
05-20-30 PgBlk 1	Remove Life Extension Inspection Requirements from AMM. Supersedes 06-117751-TR05-15.
05-20-50 PgBlk 1	Add inspection of left side FS 133 at the junction of LH Frame FS 133 and LH Aft Lower Windshield Beam. Supersedes 06-117751-TR05-15.
05-30-41 PgBlk 601	Added secondary outflow filter inspection to cabin zonal inspection. Replaced floor panel 131 CZ with 131 CZ-A and CZ 131-B due to ADS-B Installation (MB 500-34-030). Supersedes 06-117751-TR05-16 and 06-117751-TR05-18.

THIS PAGE INTENTIONALLY LEFT BLANK

TIME LIMITS/MAINTENANCE CHECKS

AMM-05-00-00-081-801

1. General

SUBTASK AMM-05-00-00-081-211-001

A. Maintenance requirements:

- (1) Time Limits; see [AMM-05-10-00-081-801 – Time Limits](#).
 - (a) Time Limited Maintenance Requirements
- (2) Scheduled Maintenance Checks; see [AMM-05-20-00-081-801 – Scheduled Maintenance Checks](#).
 - (a) 300 Hour/24 Month Inspection
 - (b) 1,200 Hour Inspection/48 Month Inspection
 - (c) — DELETED —
 - (d) Structural Inspection
- (3) Inspection procedures; see [AMM-05-30-00-021-801 – Inspection Procedures](#).
 - (a) Pre-inspection Operational Checks
 - (b) Forward Fuselage Zonal Inspection
 - (c) Wings Zonal Inspection
 - (d) Cockpit and Cabin Equipment Zonal Inspection
 - (e) Cabin Zonal Inspection
 - (f) Cockpit Zonal Inspection
 - (g) Fuselage Center Section Exterior Zonal Inspection
 - (h) Aft Fuselage Zonal Inspection
 - (i) Empennage Zonal Inspection
 - (j) Engine/Pylon Zonal Inspection
 - (k) Post Inspection Checks
- (4) Unscheduled Maintenance Checks; see [AMM-05-50-00-081-801 – Unscheduled Maintenance Checks](#).
 - (a) Inspection After Hard Landing/Over Gross Landing
 - (b) Inspection After Severe Turbulence/Maneuvers
 - (c) Inspection After Flap Overspeed
 - (d) Inspection After Gear Overspeed
 - (e) Inspection After Lightning Strike
 - (f) Inspection After Lightning Strike

(g) Inspection After Engine Fire

B. Responsibility for airworthiness.

- (1) The owner/operator is primarily responsible for maintaining the aircraft in an airworthy condition including:
 - (a) Compliance with any Federal Aviation Administration (FAA) Airworthiness Directives (ADs).
 - (b) Compliance with the Airworthiness Limitations found in [AMM-04-00-00-081-801 – Airworthiness Limitations](#).
 - (c) Compliance with the maintenance requirements found in [AMM-05-10-00-081-801 – Time Limits](#), and [AMM-05-20-00-081-801 – Scheduled Maintenance Checks](#) of this manual, or another approved aircraft inspection program in accordance with FAR part 91.409.
 - (d) Compliance with Mandatory Service Bulletins is the responsibility of the Owner/ Operator as a part of this inspection program.
 - (e) Compliance with any other requirements imposed by Airworthiness Authorities of the country of registry and/or operation.

TIME LIMITED MAINTENANCE REQUIREMENTS

AMM-05-10-10-081-801

1. General

SUBTASK AMM-05-10-10-081-211-001

A. Time limited maintenance requirements

NOTE: Also see Airworthiness Limitations. Refer to [AMM-04-00-00-081-801 – Airworthiness Limitations](#).

B. Inspection Grace Periods

The specific aircraft systems/items included in [Table 1](#) are intended to be inspected at the inspection intervals listed. In order to provide scheduling flexibility, the inspection intervals may be exceeded by the applicable grace periods as provided in [Table 1](#). The inspection intervals plus applicable grace periods must not be exceeded without approval of the operator's regulatory authority.

Table 1. Time Limited Maintenance Requirements

System/Item	Task	Interval
Chapter 21 – Air Conditioning		
<ul style="list-style-type: none"> • Secondary Outflow valve filter 	<ul style="list-style-type: none"> • Discard 	<ul style="list-style-type: none"> • 1200 hours – Grace Period: <i>50 hours</i>
<ul style="list-style-type: none"> • VCS-GDCA Compressor Pallet Assembly P/N: 2188131 	<ul style="list-style-type: none"> • Change gear box oil 	<ul style="list-style-type: none"> • At first 300 hours – Grace Period: <i>30 hours</i> <p><u>NOTE:</u> This task is required only once after the first 300 hours of operation. Refer to AMM-21-00-00-061-B-801 – Air Conditioning - Servicing.</p>

EFFECTIVITY: ALL

05-10-10

System/Item	Task	Interval
Chapter 22 — Autoflight		
<ul style="list-style-type: none"> Pitch Servo Clutch 	<ul style="list-style-type: none"> Check/Adjust the Pitch Servo Clutch torque . Refer to AMM-22-10-11-071-801 – Pitch Servo Clutch - Adjustment/Test. 	<ul style="list-style-type: none"> 1200 hours – Grace Period: <i>50 hours</i>
Chapter 25 — Equipment and Furnishings		
<ul style="list-style-type: none"> Artex ME406 ELT 	<ul style="list-style-type: none"> Self test. Refer to AMM-25-60-00-071-801 – Emergency Equipment - Adjustment/Test. Inspect per FAR 91.207 Replace battery 	<ul style="list-style-type: none"> 12 calendar months – Grace Period: <i>None</i> 12 calendar months – Grace Period: <i>None</i> Replace in accordance with manufacturer's service life.
<ul style="list-style-type: none"> Portable cockpit/cabin fire extinguisher H3R model RT A600 	<ul style="list-style-type: none"> Inspect extinguisher. Refer to AMM-25-60-00-021-801 – Emergency Equipment - Inspection/Check. Weigh extinguisher. Refer to AMM-25-60-00-021-801 – Emergency Equipment - Inspection/Check. Remove extinguisher from service. Refer to AMM-25-61-10-001-801 – Fire Extinguisher - Removal. 	<ul style="list-style-type: none"> 12 months – Grace Period: <i>None</i> 12 months – Grace Period: <i>None</i> 12 years – Grace Period: <i>None</i>

System/Item	Task	Interval
Chapter 27 — Flight Controls		
<ul style="list-style-type: none"> Flight Control Cables 	<ul style="list-style-type: none"> Tension check 	<ul style="list-style-type: none"> At first 100 hours, 300 hours thereafter <ul style="list-style-type: none"> – Grace Period: <i>10 hours, 30 hours thereafter</i> <p>NOTE: This task has been included in the 300 hour/24 month inspection. Refer to AMM-05-20-10-081-801 – 300 Hour/24 Month Inspection.</p>
Chapter 28 — Fuel		
<ul style="list-style-type: none"> Fuel Tanks 	<ul style="list-style-type: none"> Detailed Visual Inspection <p>Refer to AMM-28-10-00-021-801 – Storage - Inspection/Check.</p>	<ul style="list-style-type: none"> 48 months <ul style="list-style-type: none"> – Grace Period: <i>3 months</i>
Chapter 30 — Ice and Rain Protection		
<ul style="list-style-type: none"> Icephobic Coating 	<ul style="list-style-type: none"> Inspect. Refer to AMM-30-30-01-071-801 – Icephobic Coating - Adjustment/Test. 	<ul style="list-style-type: none"> 200 hours or 12 months <ul style="list-style-type: none"> – Grace Period: <i>20 hours or 15 days as applicable</i> <p>(whichever occurs first)</p>
Chapter 31 — Indicating and Recording Systems		
<ul style="list-style-type: none"> Data Storage Unit 	<ul style="list-style-type: none"> Do the download of DSU data. Refer to AMM-31-30-00-071-801 – Aircraft Recorders - Adjustment/Test. 	<ul style="list-style-type: none"> At each scheduled maintenance check <ul style="list-style-type: none"> – Grace Period: <i>None</i> <p>NOTE: It is recommended that this task is accomplished at each unscheduled maintenance visit when the equipment is available and time permits.</p>

System/Item	Task	Interval
Chapter 32 – Landing Gear		
<ul style="list-style-type: none"> Wheel Speed Transducer (WST) PN D202106 	<ul style="list-style-type: none"> Return to EAI or FAA Approved Facility for inspection and functional test. 	<ul style="list-style-type: none"> 1500 flight cycles – Grace Period: <i>50 flight cycles</i>
<ul style="list-style-type: none"> Main Wheel PN 40-440 	<ul style="list-style-type: none"> Inspect. Refer to AMM-32-42-00-021-801 – Wheel and Tire - Inspection/Check. 	<ul style="list-style-type: none"> Tire change – Grace Period: <i>None</i>
<ul style="list-style-type: none"> Main Wheel PN 40-440 – Wheels with 0 to 4999 Landings 	<ul style="list-style-type: none"> Inspect. Refer to AMM-32-42-00-021-801 – Wheel and Tire - Inspection/Check, SUBTASK -004. 	<ul style="list-style-type: none"> Every second Tire change – Grace Period: <i>None</i>
<ul style="list-style-type: none"> Main Wheel PN 40-440 – Wheels with 5000 or more Landings 	<ul style="list-style-type: none"> Inspect. Refer to AMM-32-42-00-021-801 – Wheel and Tire - Inspection/Check, SUBTASK -005. 	<ul style="list-style-type: none"> Every Tire change – Grace Period: <i>None</i>
<ul style="list-style-type: none"> Main Landing Gear Strut Fluid 	<ul style="list-style-type: none"> Drain and replenish. Refer to AMM-12-10-06-061-801 – Landing Gear - Servicing. 	<ul style="list-style-type: none"> 3000 hours or 3 years – Grace Period: <i>75 hours or 3 months as applicable</i> (whichever occurs first)
<ul style="list-style-type: none"> Nose Wheel PN 40-432 	<ul style="list-style-type: none"> Inspect. Refer to AMM-32-42-00-021-801 – Wheel and Tire - Inspection/Check, SUBTASK AMM-32-42-00-021-211-003. 	<ul style="list-style-type: none"> Tire change – Grace Period: <i>None</i>
<ul style="list-style-type: none"> Nose Wheel PN 40-432 – Wheels with 0 to 4999 Landings 	<ul style="list-style-type: none"> Inspect. Refer to AMM-32-42-00-021-801 – Wheel and Tire - Inspection/Check, SUBTASK -004. 	<ul style="list-style-type: none"> Every second Tire change – Grace Period: <i>None</i>
<ul style="list-style-type: none"> Nose Wheel PN 40-432 Wheels with 5000 or more Landings 	<ul style="list-style-type: none"> Inspect. Refer to AMM-32-42-00-021-801 – Wheel and Tire - Inspection/Check, SUBTASK -005. 	<ul style="list-style-type: none"> Every Tire change – Grace Period: <i>None</i>

System/Item	Task	Interval
<ul style="list-style-type: none"> Nose Landing Gear Strut Fluid 	<ul style="list-style-type: none"> Drain and replenish. 	<ul style="list-style-type: none"> 3000 hours or 3 years – Grace Period: <i>75 hours or 3 months as applicable.</i> (whichever occurs first)
Chapter 33 – Lights		
<ul style="list-style-type: none"> Wingtip NAV/ACL Light Assembly, Left and Right PN 84001-() 	<ul style="list-style-type: none"> Inspect. Refer to AMM-33-00-00-071-801 – Lights - Adjustment/ Test. 	<ul style="list-style-type: none"> At first 8000 hours, then 600 hours thereafter – Grace Period: <i>100 hours, then 30 hours thereafter.</i>
<ul style="list-style-type: none"> Tail ACL Light Assembly PN 84002-() 	<ul style="list-style-type: none"> Inspect. Refer to AMM-33-00-00-071-801 – Lights - Adjustment/ Test. 	<ul style="list-style-type: none"> At first 8000 hours, then 600 hours thereafter – Grace Period: <i>100 hours, then 30 hours thereafter.</i>
<ul style="list-style-type: none"> Tail Position Light Assembly PN 84004-() 	<ul style="list-style-type: none"> Inspect. Refer to AMM-33-00-00-071-801 – Lights - Adjustment/ Test. 	<ul style="list-style-type: none"> At first 8000 hours, then 600 hours thereafter – Grace Period: <i>100 hours, then 30 hours thereafter.</i>
Chapter 34 – Navigation		
<ul style="list-style-type: none"> Altimeter system and altitude reporting equipment 	<ul style="list-style-type: none"> Test and inspection (FAR 91.411) 	<ul style="list-style-type: none"> 24 calendar months – Grace Period: <i>None</i>
<ul style="list-style-type: none"> ATC Transponder 	<ul style="list-style-type: none"> Test and inspection (FAR 91.413) 	<ul style="list-style-type: none"> 24 calendar months – Grace Period: <i>None</i>
Chapter 35 – Oxygen		
<ul style="list-style-type: none"> Crew Oxygen Mask PN 174252–N1 	<ul style="list-style-type: none"> Return to EAI or FAA Approved Facility for overhaul. 	<ul style="list-style-type: none"> 6 years from DOM/ Overhaul – Grace Period: <i>None</i>
<ul style="list-style-type: none"> Passenger Oxygen Mask PN 174095-() 	<ul style="list-style-type: none"> Return to EAI or FAA Approved Facility for overhaul. 	<ul style="list-style-type: none"> 8 years from the cure date of the elastomeric components. – Grace Period: <i>None</i>

System/Item	Task	Interval
Chapter 53 – Fuselage		
<ul style="list-style-type: none"> Forward Fuselage Skin (RVSM Critical Area) 	<ul style="list-style-type: none"> Inspect. Refer to AMM-53-10-10-021-801 – Forward Fuselage - Inspection/Check. 	<ul style="list-style-type: none"> 24 calendar months – Grace Period: <i>None</i>
Chapter 56 – Windows		
<ul style="list-style-type: none"> Left Windshield Static Coating 	<ul style="list-style-type: none"> Test. Refer to AMM-56-10-10-071-801 – Windshield Static Coating - Adjustment/ Test. 	<ul style="list-style-type: none"> 50 hours
<ul style="list-style-type: none"> Right Windshield Static Coating 	<ul style="list-style-type: none"> Test. Refer to AMM-56-10-10-071-801 – Windshield Static Coating - Adjustment/ Test. 	<ul style="list-style-type: none"> 50 hours

SCHEDULED MAINTENANCE CHECKS

AMM-05-20-00-081-801

1. Inspection Requirements

SUBTASK AMM-05-20-00-081-211-001

A. The scheduled inspection intervals are as follows:

- (1) 300 flight hours (FH) or 24 calendar months (whichever occurs first)
- (2) 1,200 flight hours (FH) or 48 calendar months (whichever occurs first)
- (3) — DELETED —
- (4) Structural inspection to be accomplished at intervals specified in the Airworthiness Limitations. Refer to [AMM-04-00-00-081-801 – Airworthiness Limitations](#).
- (5) Refer to PWC EMM 05–20–00 for engine scheduled maintenance checks.

B. The aircraft is intended to be inspected at multiples of 300 hours. In order to provide scheduling flexibility, the scheduled inspection intervals may be exceeded as shown in [Table 1](#).

NOTE: Inspection intervals and maintenance requirements not listed in [Table 1](#) below must not exceed the inspection intervals plus applicable grace periods identified in Table 1 of [AMM-05-10-10-081-801 – Time Limited Maintenance Requirements](#) without approval of the operator's regulatory authority.

Table 1. Inspection Grace Periods

Inspection Interval	Grace Period - Hours	Grace Period - Months
300 Hour/24 Month	30	1
1200 Hour/48 Month	50	2

When the grace period is used to exceed the normal inspection interval the next inspection is due at the following multiple of that inspection interval.

When an inspection is accomplished early, the following inspection is due at the normal interval and the grace period may be used to reach the following multiple of that inspection interval. However, the next inspection must be accomplished no later than the normal interval plus the grace period.

NOTE: The 300 Hour/24 Month inspection and the 1200 Hour/48 Month inspection are separate and unique inspections. The grace period for the 1200 Hour/48 month inspection may not be used to exceed the grace period for the coinciding 300 Hour/24 Month inspection.

C. The inspection intervals have been established for normal aircraft operations in average environmental conditions. Aircraft operated in an area of extreme humidity, heat, cold,

EFFECTIVITY: ALL

05-20-00

dust or sand, or in an area nearby to saltwater should implement appropriate maintenance requirements, as determined by owner/operator field experience.

D. Progressive Inspection Programs

- (1) If desired, an operator may choose to accomplish the scheduled inspections described above in multiple maintenance visits under the administration of a progressive inspection plan approved in accordance with FAR part 91.409.

E. Hourly intervals are based on flight hours (weight off wheels to weight on wheels) and begin counting at the beginning of the first flight of the aircraft (i.e. EAI Production Flight Test).

Calendar intervals are based on a calendar day, month or year. Calendar intervals on new aircraft begin on the date of issuance of the Standard Certificate of Airworthiness for that specific aircraft.

NOTE: For components tracked from the date of manufacture and that are not manufactured by Eclipse Aerospace (oxygen bottle, fire extinguisher, etc.), time will begin to accrue from the date of manufacture at the supplier.

F. Inspection Terms and Definitions

Table 2. Inspection Terms and Definitions

Term	Definition
CHECK	An observation to determine if an item is fulfilling its intended purpose. A check is a failure finding task and does not require quantitative tolerances.
CYCLE	A cycle consists of one takeoff and one landing. Also see FLIGHT.
DAILY INSPECTION	Extends from the day completed for the duration of the inspection period. Unless a grace period is given.
DISCARD	The removal from service of an item at a specified life limit.
FILL	Fill to the correct level, pressure or quantity, including (as applicable) the following tasks: <ul style="list-style-type: none"> • removing caps and/or covers • examining caps, covers, gaskets and seals • installing caps and/or covers • installing appropriate locking devices
FILL-TO-SPILL	Fill the fill port until substance begins to run-over or spill.
FLIGHT	A flight shall consist of one takeoff and one landing. Also see CYCLE.
FUNCTIONAL CHECK	A quantitative check to determine if one or more functions of an item perform within specified limits.
HOURLY INSPECTION	Extends from the hour completed for the duration of the inspection period. Unless a grace period is given.

Term	Definition
INSPECT	May consist of any one of the following: <ul style="list-style-type: none"> • General Visual Inspection (GVI) – A visual examination of an area, installation or assembly to detect obvious damage, failure or irregularity. • Detailed Inspection (DET) – An intensive examination of a specific item, installation or assembly to detect damage, failure or irregularity. Available lighting is normally supplemented with a direct source of lighting at an intensity deemed appropriate. • Special Detailed Inspection (SDI) - An intensive examination of a specific item, installation or assembly to detect damage, failure or irregularity. An SDI is likely to make use of specialized inspection techniques and/or equipment.
INSTALL	Connect or attach a component or system in order to secure it in its correct position.
LUBRICATE	Apply prescribed lubricant.
MONTHLY INSPECTION	Extends from any day of the month to the last day of month for the inspection period. Unless a grace period is given.
OPERATIONAL CHECK	A task to determine that an item is fulfilling its intended purpose. The check is a failure finding task and does not require quantitative tolerances.
REMOVE	Disconnect and/or detach a component or system in order to remove it from its installed position.
REMOVE AND REPLACE	Remove a component or system and install a new or serviceable component or system in its place.
YEARS	Extends for any day of the month to the last day of the month for the inspection period. Unless a grace period is given.

THIS PAGE INTENTIONALLY LEFT BLANK

300 HOUR/24 MONTH INSPECTION

AMM-05-20-10-081-801

1. General

- A. The following tasks are to be accomplished at an interval of each 300 flight hours or each 24 months, whichever comes first.

NOTE: The terms used in this checklist are defined in [AMM-05-20-00-081-801 – Scheduled Maintenance Checks](#).

- B. Refer to PWC EMM 05–20–00 for engine scheduled maintenance checks.

2. Job Set-Up

SUBTASK AMM-05-20-10-081-921-001

- A. Make aircraft safe for maintenance. Refer to [AMM-20-00-01-051-801 – Make Safe For Maintenance](#).
- B. Remove the access panels that follow:
- (1) 121 BZ - Floor Panel, Left Cockpit. Refer to [AMM-25-11-30-001-801 – Cockpit Floor Panels - Removal](#).
 - (2) 122 AZ - Floor Panel, Right Cockpit. Refer to [AMM-25-11-30-001-801 – Cockpit Floor Panels - Removal](#).
 - (3) 221 BZ - Left Lower Cockpit Sidewall Assembly. Refer to [AMM-25-11-20-001-801 – Cockpit Panels - Removal](#).
 - (4) 222 BZ - Right Lower Cockpit Sidewall Assembly. Refer to [AMM-25-11-20-001-801 – Cockpit Panels - Removal](#).
 - (5) 221 KZ - Cockpit Overhead Console. Refer to [AMM-25-21-21-001-801 – Overhead Console - Removal](#).
 - (6) 131 AZ - Floor Panel, Forward Left Cabin. Refer to [AMM-25-21-30-001-801 – Cabin Floor Panels - Removal](#).
 - (7) 132 AZ - Floor Panel, Forward Right Cabin. Refer to [AMM-25-21-30-001-801 – Cabin Floor Panels - Removal](#).
 - (8) 131 BZ - Floor Panel, Forward Cabin Center. Refer to [AMM-25-21-30-001-801 – Cabin Floor Panels - Removal](#).
 - (9) 131 CZ - Floor Panel, Aft Left Cabin. Refer to [AMM-25-21-30-001-801 – Cabin Floor Panels - Removal](#).
 - (10) 131 CZ-A - Floor Panel, Aft Long, Left Cabin (POST MB 500–34–30). Refer to [AMM-25-21-30-001-801 – Cabin Floor Panels - Removal](#).

EFFECTIVITY: ALL

05-20-10

- (11) 131 CZ-B - Floor Panel, Aft Short, Left Cabin (POST MB 500–34–30). Refer to [AMM-25-21-30-001-801 – Cabin Floor Panels - Removal](#).
NOTE: Remove fasteners only. Leave floor panel in place. The GPS 3 (GDL88 Unit) is attached to the underside of the panel. Inspection can be accomplished by lifting the panel from the forward edge and rotating the panel aft. If removal is required, refer to [AMM-34-50-11-001-C-801 – GPS 3 - Removal](#) and [AMM-34-50-13-001-801 – GPS 3 Mount - Removal](#).
- (12) 131 DZ - Floor Panel, Aft Cabin Center. Refer to [AMM-25-21-30-001-801 – Cabin Floor Panels - Removal](#).
- (13) 132 BZ - Floor Panel, Aft Right Cabin. Refer to [AMM-25-21-30-001-801 – Cabin Floor Panels - Removal](#).
- (14) 231 MZ - Baggage Step Panel. Refer to [AMM-25-21-20-001-801 – Cabin Panels - Removal](#).
- (15) 231 NZ - Floor Panel, Baggage Compartment. Refer to [AMM-25-21-30-001-801 – Cabin Floor Panels - Removal](#).
- (16) 231 KZ - Cabin Oxygen Box Cover. Refer to [AMM-27-51-10-041-801 – Flap Control Surface - Installation](#) for access panel location.
- (17) 231 LZ - Cabin Oxygen Box Cover. Refer to [AMM-27-51-10-041-801 – Flap Control Surface - Installation](#) for access panel location.
- (18) 231 JZ - Cabin Headliner Assembly. Refer to [AMM-25-21-20-001-801 – Cabin Panels - Removal](#).
- (19) 232 AZ - Right Upper Sidewall Panel. Refer to [AMM-25-21-20-001-801 – Cabin Panels - Removal](#).
- (20) 232 FZ - Right Lower Cabin Sidewall Assembly. Refer to [AMM-25-21-20-001-801 – Cabin Panels - Removal](#).
- (21) 241 JZ - Upper Door Panel. Refer to [AMM-25-21-23-001-801 – Upper Door Panel - Removal](#).
- (22) 241 HZ - Lower Cabin Door Panel Closeout. Refer to [AMM-06-50-00-051-801 – Aircraft Access Panels](#) for access panel location.
- (23) 231 FZ - Left Upper Sidewall Panel. Refer to [AMM-25-21-20-001-801 – Cabin Panels - Removal](#).
- (24) 231 AZ - Left Lower Cabin Sidewall Assembly. Refer to [AMM-25-21-20-001-801 – Cabin Panels - Removal](#).
- (25) 231 PZ - Aft Bulkhead Panel. Refer to [AMM-25-21-20-001-801 – Cabin Panels - Removal](#).
- (26) 231 HZ - APC/PDC Cover Panel. Refer to [AMM-25-21-20-001-801 – Cabin Panels - Removal](#).
- (27) 211 CT - Nose Access Panel. Refer to [AMM-53-10-11-001-801 – Nose Access Panel - Removal](#).
- (28) 211 EL - Oxygen Service Door. Refer to [AMM-06-50-00-051-801 – Aircraft Access Panels](#) for access panel location.

-
- (29) 211 JZ - Oxygen Bottle Cover. Refer to [AMM-06-50-00-051-801 – Aircraft Access Panels](#) for access panel location.
 - (30) 251 CL - Left Forward Wing-to-Body Fairing. Refer to [AMM-53-11-12-001-801 – Forward Wing to Body Fairing Assembly - Removal](#).
 - (31) 251 EL - Left Lower Wing-to-Body Fairing. Refer to [AMM-53-11-11-001-801 – Lower Wing to Body Fairing Assembly - Removal](#).
 - (32) 252 BR - Right Forward Wing-to-Body Fairing. Refer to [AMM-53-11-12-001-801 – Forward Wing to Body Fairing Assembly - Removal](#).
 - (33) 252 DR - Right Lower Wing-to-Body Fairing. Refer to [AMM-53-11-11-001-801 – Lower Wing to Body Fairing Assembly - Removal](#).
 - (34) 721 AL - Left Forward NLG Door. Refer to [AMM-52-81-10-001-801 – Nose Gear Forward Doors - Removal](#).
 - (35) 721 CR - Right Forward NLG Door. Refer to [AMM-52-81-10-001-801 – Nose Gear Forward Doors - Removal](#).
 - (36) 311 AL - Maintenance Bay Panel. Refer to [AMM-53-40-10-001-801 – Maintenance Bay Panel - Removal](#).
 - (37) 411 AT - Left Upper Nacelle Cowl. Refer to [AMM-54-20-21-001-801 – Upper Nacelle - Removal](#).
 - (38) 411 CB - Left Lower Nacelle Cowl. Refer to [AMM-54-20-22-001-801 – Lower Nacelle - Removal](#).
 - (39) 412 AT - Right Upper Nacelle Cowl. Refer to [AMM-54-20-21-001-801 – Upper Nacelle - Removal](#).
 - (40) 412 CB - Right Lower Nacelle Cowl. Refer to [AMM-54-20-22-001-801 – Lower Nacelle - Removal](#).
 - (41) 331 DT - Upper Overfin Fairing. Refer to [AMM-55-10-12-001-801 – Overfin Fairing - Removal](#).
 - (42) Engine Mount Insulating Covers. Refer to [AMM-06-50-00-051-801 – Aircraft Access Panels](#).

NOTE: If the fasteners removed from the exterior removable panels and fairings are replaced with unplated or uncoated stainless steel fasteners, there is an increased risk of galvanic corrosion of the fastener holes in the underlying aluminum structure. If unplated or uncoated fasteners have been installed in these locations, do a general visual inspection for corrosion of the fastener holes in the underlying aluminum structure. Refer to [AMM-20-10-00-051-801 – Corrosion](#).

3. Procedure

SUBTASK AMM-05-20-10-081-211-001

A. 300 Hour/24 Month Inspection

MODEL: EA500	
A/C SERIAL NO:	
A/C REGISTRATION NO:	
INSPECTION DUE TIME/DATE:	
INSPECTION START TIME/DATE:	
INSPECTION FINISH TIME/DATE:	
NOTE: Make sure that all of the inspection requirements have been completed and signed off.	

INSPECTION	MECH	INSP	DATE
PRE-INSPECTION CHECKS			
Compliance with Mandatory Service Bulletins is the responsibility of the Owner/Operator as a part of this inspection program. Perform a review of the aircraft records. Notify the operator of any due Mandatory Service Bulletins. Record any Mandatory Service Bulletins that are due and have not been completed in the aircraft logbooks.			
Check the displays for Crew Alerting System (CAS) messages. Any existing malfunctions must be repaired prior to doing this procedure.			
Check for freedom of movement of all flight and trim control surfaces.			
Do the PFD/MFD backlighting adjustment. Refer to AMM-31-10-00-071-801 – Displays and Control Panels - Adjustment/Test , SUBTASK AMM-31-10-00-071-A B C-701-023, where X is A, B, or C.			
Do a functional check of the DSU, flight history file off load and DSU data transfer. Refer to AMM-31-30-00-071-801 – Aircraft Recorders - Adjustment/Test .			
Do an operational check of the single left and single right aircraft computer system. Refer to AMM-31-40-00-071-801 – Aircraft Computer Systems - Adjustment/Test , SUBTASK AMM-31-40-00-071-701-001 and -002.			

EFFECTIVITY: ALL

05-20-10

Page 4
Apr 24/19

INSPECTION	MECH	INSP	DATE
For aircraft 0001-0265 POST SB 500-99-005 and 0266-9999, do a functional check of the flow control valve. Refer to AMM-21-40-20-071-801 – Flow Control Valve (FCV) - Adjustment/ Test.			
Do an operational check of the smoke clearing function of the cabin pressurization system. Refer to AMM-21-30-05-071-801 – CPCS Smoke Clearing - Adjustment/Test.			
Do an operational check of the dual generator load shed function and the electrical smoke clearing function. Refer to AMM-24-60-00-071-801 – Electrical Power Distribution System Modes - Adjustment/Test.			
Do an operational check of the wing and stabilizer deice system. Refer to AMM-30-10-10-071-801 – Airfoil Deice System - Adjustment/Test , SUBTASK AMM-30-10-10-071-781-002.			
INSPECTION/CHECK			
Do a general visual inspection of the cabin and cockpit. Refer to AMM-05-30-40-021-801 – Cockpit And Cabin Equipment Zonal Inspection.			
Do a general visual inspection of the cabin. Refer to AMM-05-30-41-021-801 – Cabin Zonal Inspection.			
Do a general visual inspection of the cockpit. Refer to AMM-05-30-42-021-801 – Cockpit Zonal Inspection.			
Do a Inspection/Check on the Passenger Door Handle. Refer to AMM-52-00-00-021-801 – Doors - Inspection/Check.			
Perform a general visual inspection for condition and security of the windshield resistive strips. Inspect for damage to, or exposure of, inner (dark resistive) layer. Inspect for areas where the strip may have peeled away from the windshield surface. <u>NOTE:</u> This check required for aircraft 0001-0265 post SB 500-56-002 and 0266-9999.			
Do a general visual inspection of the forward fuselage bay. Refer to AMM-05-30-20-021-801 – Forward Fuselage Zonal Inspection.			
Do a general visual inspection of the nose landing gear. Refer to AMM-32-20-00-021-801 – Nose Gear and Doors - Inspection/Check.			
Do a general visual inspection of the steering mechanism. Refer to AMM-32-50-00-021-801 – Steering - Inspection/Check.			
Do a general visual inspection of the exterior center section of the fuselage. Refer to AMM-05-30-50-021-801 – Fuselage Center Section Exterior Zonal Inspection.			

EFFECTIVITY: ALL

05-20-10

INSPECTION	MECH	INSP	DATE
Do a general visual inspection of the left and right wing. Refer to AMM-05-30-30-021-801 – Wings Zonal Inspection.			
Do a general visual inspection of left and right main landing gear. Refer to AMM-32-10-00-021-801 – Main Gear and Doors - Inspection/Check.			
Do a general visual inspection of the left and right brakes. Refer to AMM-32-41-15-021-801 – Main Landing Gear Brake Assembly - Inspection/Check.			
Do a general visual inspection of the aft fuselage and aft equipment bay. Refer to AMM-05-30-60-021-801 – Aft Fuselage Zonal Inspection.			
Do a general visual inspection of the engine and pylon. Refer to AMM-05-30-80-021-801 – Engine/Pylon Zonal Inspection.			
Do a general visual inspection of the empennage. Refer to AMM-05-30-70-021-801 – Empennage Zonal Inspection.			
OPERATIONAL/FUNCTIONAL CHECKS			
Perform the Dual Power Source Test for Avionics. Refer to AMM-24-00-00-071-801 – Electrical Power - Adjustment/Test..			
Drain the pitot/AOA probe and static systems. Refer to AMM-34-10-00-061-801 – Flight Environment Data - Servicing.			
Do a functional check of the air data system. Refer to AMM-34-10-00-071-801 – Flight Environment Data - Adjustment/ Test. NOTE: This functional test is not required for each 300 hour inspection interval (high usage) but it must be completed once each 24 calendar month interval as required per FAR part 91.411.			
Do a test of the static ports, pitot/AOA probes, standby pitot/static probe, and anti-ice system. Refer to AMM-30-30-00-071-801 – Pitot and Static Anti-Ice System - Adjustment/Test.			
Do an operational check of the stick pusher. Refer to AMM-22-00-00-071-801 – Auto Flight System - Adjustment/Test , SUBTASK AMM-22-00-00-071-701-001.			
Do a operational check of the fire detection system. Refer to AMM-26-10-00-071-801 – Fire Detection Wire - Adjustment/Test.			
Do a functional check of the passenger oxygen system deployment. Refer to AMM-35-00-00-071-801 – Oxygen System - Adjustment/ Test.			

INSPECTION	MECH	INSP	DATE
Do a operational check of the right battery bus contactor of the forward power distribution center. Refer to AMM-24-60-10-071-801 – Forward Power Distribution Center - Adjustment/Test . NOTE: This check is only required for Avidyne equipped aircraft that do not have SB 500-31-006 incorporated.			
Do a tension check of all flight control cables. Refer to AMM-27-00-01-071-801 – Flight Controls - Adjustment/Test (Rigging) . NOTE: Completion of the entire rigging task is not required. Only do the cable tension check steps identified as scheduled maintenance in the task.			
Do a functional check of the landing gear extension/retraction system. Refer to AMM-32-30-00-071-801 – Extension and Retraction - Adjustment/Test .			
SERVICING			
Do a servicing of the brake reservoir as necessary. Refer to AMM-12-10-02-061-801 – Brake - Servicing .			
Do a servicing of the tires. Refer to AMM-12-10-04-061-801 – Tires - Servicing .			
Do a servicing of the landing gear struts. Refer to AMM-12-10-06-061-801 – Landing Gear - Servicing .			
Do a servicing of the wheel bearings. Refer to AMM-12-20-05-061-801 – Wheel Bearing - Servicing .			
Brush or spray on the Corrosion Preventative Lubricant ZIP-Chem D-5026NS or equivalent to MIL-PRF-81309, Type II, class 1 or 2 to the landing gear components. Refer to AMM-12-20-04-011-801 – Landing Gear Corrosion Preventative - Servicing .			
POST INSPECTION CHECKS			
Do the post inspection checks. Refer to AMM-05-30-90-021-801 – Post Inspection Checks .			

4. Job Close-Up

SUBTASK AMM-05-20-10-081-921-002

- A. Remove all tools, equipment and unwanted material from work area.
- B. Install the access panels that follow:
 - (1) 121 BZ - Floor Panel, Left Cockpit. Refer to [AMM-25-11-30-041-801 – Cockpit Floor Panels - Installation](#).

- (2) 122 AZ - Floor Panel, Right Cockpit. Refer to [AMM-25-11-30-041-801 – Cockpit Floor Panels - Installation](#).
- (3) 221 BZ - Left Lower Cockpit Sidewall Assembly. Refer to [AMM-25-11-20-041-801 – Cockpit Panels - Installation](#).
- (4) 222 BZ - Right Lower Cockpit Sidewall Assembly. Refer to [AMM-25-11-20-041-801 – Cockpit Panels - Installation](#).
- (5) 221 KZ - Cockpit Overhead Console. Refer to [AMM-25-21-21-041-801 – Overhead Console - Installation](#).
- (6) 131 AZ - Floor Panel, Forward Left Cabin. Refer to [AMM-25-21-30-041-801 – Cabin Floor Panels - Installation](#).
- (7) 132 AZ - Floor Panel, Forward Right Cabin. Refer to [AMM-25-21-30-041-801 – Cabin Floor Panels - Installation](#).
- (8) 131 BZ - Floor Panel, Forward Cabin Center. Refer to [AMM-25-21-30-041-801 – Cabin Floor Panels - Installation](#).
- (9) 131 CZ - Floor Panel, Aft Left Cabin. Refer to [AMM-25-21-30-041-801 – Cabin Floor Panels - Installation](#).
- (10) 131 CZ-A - Floor Panel, Aft Long, Left Cabin (POST MB 500–34–30). Refer to [AMM-25-21-30-041-801 – Cabin Floor Panels - Installation](#).
- (11) 131 CZ-B - Floor Panel, Aft Short, Left Cabin (POST MB 500–34–30). Refer to [AMM-25-21-30-041-801 – Cabin Floor Panels - Installation](#).
- (12) 131 DZ - Floor Panel, Aft Cabin Center. Refer to [AMM-25-21-30-041-801 – Cabin Floor Panels - Installation](#).
- (13) 132 BZ - Floor Panel, Aft Right Cabin. Refer to [AMM-25-21-30-041-801 – Cabin Floor Panels - Installation](#).
- (14) 231 MZ - Baggage Step Panel. Refer to [AMM-25-21-20-041-801 – Cabin Panels - Installation](#).
- (15) 231 NZ - Floor Panel, Baggage Compartment. Refer to [AMM-25-21-30-041-801 – Cabin Floor Panels - Installation](#).
- (16) 231 KZ - Cabin Oxygen Box Cover. Refer to [AMM-06-50-00-051-801 – Aircraft Access Panels](#) for access panel location.
- (17) 231 LZ - Cabin Oxygen Box Cover. Refer to [AMM-06-50-00-051-801 – Aircraft Access Panels](#) for access panel location.
- (18) 231 JZ - Cabin Headliner Assembly. Refer to [AMM-25-21-20-041-801 – Cabin Panels - Installation](#).
- (19) 232 AZ - Right Upper Sidewall Panel. Refer to [AMM-25-21-20-041-801 – Cabin Panels - Installation](#).
- (20) 232 FZ - Right Lower Cabin Sidewall Assembly. Refer to [AMM-25-21-20-041-801 – Cabin Panels - Installation](#).
- (21) 241 JZ - Upper Door Panel. Refer to [AMM-25-21-23-041-801 – Upper Door Panel - Installation](#).

-
- (22) 241 HZ - Lower Cabin Door Panel Closeout. Refer to [AMM-06-50-00-051-801 – Aircraft Access Panels](#) for access panel location.
 - (23) 231 FZ - Left Upper Sidewall Panel. Refer to [AMM-25-21-20-041-801 – Cabin Panels - Installation](#).
 - (24) 231 AZ - Left Lower Cabin Sidewall Assembly. Refer to [AMM-25-21-20-041-801 – Cabin Panels - Installation](#).
 - (25) 231 PZ - Aft Bulkhead Panel. Refer to [AMM-25-21-20-041-801 – Cabin Panels - Installation](#).
 - (26) 231 HZ - APC/PDC Cover Panel. Refer to [AMM-25-21-20-041-801 – Cabin Panels - Installation](#).
 - (27) 211 CT - Nose Access Panel. Refer to [AMM-53-10-11-041-801 – Nose Access Panel - Installation](#).
 - (28) 211 EL - Oxygen Service Door. Refer to [AMM-06-50-00-051-801 – Aircraft Access Panels](#) for access panel location.
 - (29) 211 JZ - Oxygen Bottle Cover. Refer to [AMM-06-50-00-051-801 – Aircraft Access Panels](#) for access panel location.
 - (30) 251 CL - Left Forward Wing-to-Body Fairing. Refer to [AMM-53-11-12-001-801 – Forward Wing to Body Fairing Assembly - Removal](#).
 - (31) 251 EL - Left Lower Wing-to-Body Fairing. Refer to [AMM-53-11-11-041-801 – Lower Wing to Body Fairing Assembly - Installation](#).
 - (32) 252 BR - Right Forward Wing-to-Body Fairing. Refer to [AMM-53-11-12-041-801 – Forward Wing to Body Fairing Assembly - Installation](#).
 - (33) 252 DR - Right Lower Wing-to-Body Fairing. Refer to [AMM-53-11-11-041-801 – Lower Wing to Body Fairing Assembly - Installation](#).
 - (34) 721 AL - Left Forward NLG Door. Refer to [AMM-52-81-10-041-801 – Nose Gear Forward Doors - Installation](#).
 - (35) 721 CR - Right Forward NLG Door. Refer to [AMM-52-81-10-041-801 – Nose Gear Forward Doors - Installation](#).
 - (36) 311 AL - Maintenance Bay Panel. Refer to [AMM-53-40-10-041-801 – Maintenance Bay Panel - Installation](#).
 - (37) 411 AT - Left Upper Nacelle Cowl. Refer to [AMM-54-20-21-041-801 – Upper Nacelle - Installation](#).
 - (38) 411 CB - Left Lower Nacelle Cowl. Refer to [AMM-54-20-22-041-801 – Lower Nacelle - Installation](#).
 - (39) 412 AT - Right Upper Nacelle Cowl. Refer to [AMM-54-20-21-041-801 – Upper Nacelle - Installation](#).
 - (40) 412 CB - Right Lower Nacelle Cowl. Refer to [AMM-54-20-22-041-801 – Lower Nacelle - Installation](#).
 - (41) 331 DT - Upper Overfin Fairing. Refer to [AMM-55-10-12-041-801 – Overfin Fairing - Installation](#).

- (42) Engine Mount Insulating Covers. Refer to [AMM-06-50-00-051-801 – Aircraft Access Panels](#).
- C. If all other maintenance is complete, return aircraft to service. Refer to [AMM-20-00-02-051-801 – Return To Service \(After Maintenance\)](#).

1200 HOUR/48 MONTH INSPECTION

AMM-05-20-20-081-801

1. General

- A. The following tasks are to be accomplished at an interval of each 1200 flight hours or each 48 months, whichever comes first.

NOTE: This 1200 hour/48 month inspection does not include the 300 hour/24 month inspection tasks. The 300 hour/24 month inspection requirements are independent of the 1200 hour/48 month inspection. For 300 hour/24 month inspection details, refer to [AMM-05-20-10-081-801 – 300 Hour/24 Month Inspection](#).

NOTE: The terms used in this checklist are defined in [AMM-05-20-00-081-801 – Scheduled Maintenance Checks](#).

- B. Refer to PWC EMM 05-20-00 for engine scheduled maintenance checks.

2. Job Set-Up

SUBTASK AMM-05-20-20-081-211-001

- A. Make aircraft safe for maintenance. Refer to [AMM-20-00-01-051-801 – Make Safe For Maintenance](#).
- B. Remove the crew seats. Refer to [AMM-25-11-10-001-801 – Cockpit Seat - Removal](#).
- C. Remove the passenger seats. Refer to [AMM-25-21-10-001-801 – Passenger Seat - Removal](#).
- D. Remove the access panels that follow:
- (1) Remove 121 BZ - Floor Panel, Left Cockpit. Refer to [AMM-25-11-30-001-801 – Cockpit Floor Panels - Removal](#).
 - (2) Remove 122 AZ - Floor Panel, Right Cockpit. Refer to [AMM-25-11-30-001-801 – Cockpit Floor Panels - Removal](#).
 - (3) Remove 221 BZ - Left Lower Cockpit Sidewall Assembly. Refer to [AMM-25-11-20-001-801 – Cockpit Panels - Removal](#).
 - (4) Remove 222 BZ - Right Lower Cockpit Sidewall Assembly. Refer to [AMM-25-11-20-001-801 – Cockpit Panels - Removal](#).
 - (5) Remove 221 LZ - Cockpit Headliner. Refer to [AMM-25-11-20-001-801 – Cockpit Panels - Removal](#).
 - (6) Remove 131 AZ - Floor Panel, Forward Left Cabin. Refer to [AMM-25-21-30-001-801 – Cabin Floor Panels - Removal](#).
 - (7) Remove 132 AZ - Floor Panel, Forward Right Cabin. Refer to [AMM-25-21-30-001-801 – Cabin Floor Panels - Removal](#).
 - (8) Remove 131 BZ - Floor Panel, Forward Cabin Center. Refer to [AMM-25-21-30-001-801 – Cabin Floor Panels - Removal](#).

EFFECTIVITY: ALL

05-20-20

- (9) Remove 131 CZ - Floor Panel, Aft Left Cabin. Refer to [AMM-25-21-30-001-801 – Cabin Floor Panels - Removal](#).
- (10) Remove 131 CZ-A - Floor Panel, Aft Long, Left Cabin (POST MB 500–34–30). Refer to [AMM-25-21-30-001-801 – Cabin Floor Panels - Removal](#).
- (11) Remove 131 CZ-B - Floor Panel, Aft Short, Left Cabin (POST MB 500–34–30). Refer to [AMM-25-21-30-001-801 – Cabin Floor Panels - Removal](#).

NOTE: Remove fasteners only. Leave floor panel in place. The GPS 3 (GDL88 Unit) is attached to the underside of the panel. Inspection can be accomplished by lifting the panel from the forward edge and rotating the panel aft. If removal is required, refer to [AMM-34-50-11-001-C-801 – GPS 3 - Removal](#) and [AMM-34-50-13-001-801 – GPS 3 Mount - Removal](#).
- (12) Remove 131 DZ - Floor Panel, Aft Cabin Center. Refer to [AMM-25-21-30-001-801 – Cabin Floor Panels - Removal](#).
- (13) Remove 132 BZ - Floor Panel, Aft Right Cabin. Refer to [AMM-25-21-30-001-801 – Cabin Floor Panels - Removal](#).
- (14) Remove 231 MZ - Baggage Step Panel. Refer to [AMM-25-21-20-001-801 – Cabin Panels - Removal](#).
- (15) Remove 231 NZ - Floor Panel, Baggage Compartment. Refer to [AMM-25-21-30-001-801 – Cabin Floor Panels - Removal](#).
- (16) Remove 241 HZ - Lower Cabin Door Panel Closeout. Refer to [AMM-25-21-22-001-801 – Lower Door Panel - Removal](#).
- (17) 251 EL - Left Lower Wing-to-Body Fairing. Refer to [AMM-53-11-11-001-801 – Lower Wing to Body Fairing Assembly - Removal](#).
- (18) 252 DR - Right Lower Wing-to-Body Fairing. Refer to [AMM-53-11-11-001-801 – Lower Wing to Body Fairing Assembly - Removal](#).
- (19) Remove 251 CL - Left Forward Wing-to-Body Fairing. Refer to [AMM-53-11-12-001-801 – Forward Wing to Body Fairing Assembly - Removal](#).
- (20) Remove 252 BR - Right Forward Wing-to-Body Fairing. Refer to [AMM-53-11-12-001-801 – Forward Wing to Body Fairing Assembly - Removal](#).
- (21) Remove 251 FL - Left Aft Wing-to-Body Fairing. Refer to [AMM-53-11-13-001-801 – Aft Wing To Body Fairing - Removal](#).
- (22) Remove 252 EL - Right Aft Wing-to-Body Fairing. Refer to [AMM-53-11-13-001-801 – Aft Wing To Body Fairing - Removal](#).
- (23) Remove 511 HB - Left Main Landing Gear Access Panel. Refer to [AMM-06-50-00-051-801 – Aircraft Access Panels](#) for access panel location.
- (24) Remove 612 HB - Outboard Flap Actuator Panel. Refer to [AMM-06-50-00-051-801 – Aircraft Access Panels](#) for access panel location.
- (25) Remove 311 AL - Maintenance Bay Panel. Refer to [AMM-53-40-10-001-801 – Maintenance Bay Panel - Removal](#).
- (26) Remove 321 BT - Vertical Leading Edge. Refer to [AMM-55-30-12-001-801 – Vertical Stabilizer Leading Edge Fairing - Removal](#).

- (27) Remove 321 DB - Vertical Access Panel. Refer to [AMM-55-30-13-001-801 – Vertical Stabilizer Lower Access Panel - Removal](#).
- (28) Remove 331 DT - Upper Overfin Fairing. Refer to [AMM-55-10-12-001-801 – Overfin Fairing - Removal](#).
- (29) Remove 311 EL - Left Pylon Leading Edge. Refer to [AMM-54-30-11-001-801 – Leading Edge Pylon Skin - Removal](#).
- (30) Remove 312 BR - Right Pylon Leading Edge. Refer to [AMM-54-30-11-001-801 – Leading Edge Pylon Skin - Removal](#).

3. Procedure

SUBTASK AMM-05-20-20-081-211-002

A. 1200 Hour/48 Month Inspection

MODEL: EA500	
A/C SERIAL NO:	
A/C REGISTRATION NO:	
INSPECTION DUE TIME/DATE:	
INSPECTION START TIME/DATE:	
INSPECTION FINISH TIME/DATE:	
NOTE: Make sure that all of the inspection requirements have been completed and signed off.	

INSPECTION	MECH	INSP	DATE
PRE-INSPECTION CHECKS			
Do an operational check of the engine intake anti-ice system. Refer to AMM-30-20-10-071-801 – Engine Inlet Anti-Ice - Adjustment/Test .			
Do an operational check of the windshield anti-ice system. Refer to AMM-30-40-00-071-801 – Windshield Heat System - Adjustment/Test .			
Do an operational check of the VCS system. Refer to AMM-21-00-00-071-801 – Air Conditioning - Adjustment/Test .			
INSPECTION/CHECK			
Do a detailed visual inspection of the External Power Receptacle. Refer to AMM-24-40-11-021-801 – External Power Receptacle - Inspection/Check .			
Do a detailed visual inspection of the entrance stairs. Refer to AMM-52-60-00-021-801 – Entrance Stairs - Inspection/Check .			

EFFECTIVITY: ALL

05-20-20

INSPECTION	MECH	INSP	DATE
Do a detailed visual inspection of the aileron control system. Refer to AMM-27-10-00-021-801 – Aileron - Inspection/Check , SUBTASK AMM-27-10-00-021-221-002.			
Do a detailed visual inspection of the rudder control system. Refer to AMM-27-20-00-021-801 – Rudder and Tab - Inspection/Check , SUBTASK AMM-27-20-00-021-221-002.			
Do a detailed visual inspection of the elevator control system. Refer to AMM-27-30-00-021-801 – Elevator and Tab - Inspection/Check , SUBTASK AMM-27-30-00-021-221-002.			
Do a detailed visual inspection of the flap control system. Refer to AMM-27-50-00-021-801 – Flaps - Inspection/Check , SUBTASK AMM-27-50-00-021-221-002.			
Do a detailed visual inspection of the airfoil deice system. Refer to AMM-30-10-10-021-801 – Airfoil Deice System - Inspection/Check , SUBTASK AMM-30-10-10-021-X-221-002, where X is A or B.			
Do a detailed visual inspection of the fuel system. Refer to AMM-28-00-00-021-801 – Fuel System - Inspection/Check , SUBTASK AMM-28-00-00-021-X-201-002, where X is A or B.			
Do a general visual inspection of the exterior center section of the fuselage. Refer to AMM-05-30-50-021-801 – Fuselage Center Section Exterior Zonal Inspection . <u>NOTE</u> : Requires the removal and inspection under the access panels indicated for a 1200 hour inspection.			
Do a detailed visual inspection of the landing gear extension/retraction system. Refer to AMM-32-30-00-021-801 – Extension and Retraction - Inspection/Check .			
Do a general visual inspection of the Aft fuselage area. Refer to AMM-05-30-60-021-801 – Aft Fuselage Zonal Inspection . <u>NOTE</u> : Requires the removal and inspection under the access panels indicated for a 1200 hour inspection.			
Do a general visual inspection of the empennage. Refer to AMM-05-30-70-021-801 – Empennage Zonal Inspection . <u>NOTE</u> : Requires the removal and inspection under the access panels indicated for a 1200 hour inspection.			
Do a detailed visual inspection cockpit and cabin VCS cooling system components. Refer to AMM-21-50-00-021-801 – Cooling System - Inspection/Check .			
Do a general visual inspection of the static dischargers. Refer to AMM-23-60-00-021-801 – Static Discharging - Inspection/Check .			

INSPECTION	MECH	INSP	DATE
Do a resistance check of the static dischargers. Refer to AMM-23-60-00-071-801 – Static Discharging - Adjustment/Test.			
OPERATIONAL/FUNCTIONAL CHECKS			
Do a functional check of the pressurization system. Refer to AMM-21-30-00-071-801 – Cabin Pressurization Control System - Adjustment/Test.			
Do a functional check of the ILS system. Refer to AMM-34-30-00-071-801 – Landing and Taxiing Aids - Adjustment/Test.			
Do a functional check of the flight control system. Refer to AMM-27-00-00-071-801 – Flight Controls - Adjustment/Test (Functional Check).			
Do a functional check of the fire extinguisher cartridge control system. Refer to AMM-26-20-00-071-801 – Fire Extinguisher Cartridge Control - Adjustment/Test.			
SERVICING			
Replace the filter of the secondary outflow valve. Refer to AMM-21-30-14-001-801 – Secondary CPCS Outflow Valve Filter - Removal.			
<p>On aircraft with AVIO NG Electronic Flight Instrument System installed, remove the transponder cooling blower filter. Refer to AMM-34-50-25-001-801 – Transponder Cooling Blower Filter - Removal.</p> <p>Clean the filter using a vacuum or compressed air. Check the filter for general condition. Replace if necessary.</p> <p>Install the transponder cooling blower filter. Refer to AMM-34-50-25-041-801 – Transponder Cooling Blower Filter - Installation.</p>			
POST INSPECTION CHECKS			
Do the post inspection checks. Refer to AMM-05-30-90-021-801 – Post Inspection Checks.			

4. **Job Close-Up**

SUBTASK AMM-05-20-20-081-921-002

- A. Remove all tools, equipment and unwanted material from work area.
- B. Install the access panels that follow:
 - (1) Install 121 BZ - Floor Panel, Left Cockpit. Refer to [AMM-25-11-30-041-801 – Cockpit Floor Panels - Installation](#).
 - (2) Install 122 AZ - Floor Panel, Right Cockpit. Refer to [AMM-25-11-30-041-801 – Cockpit Floor Panels - Installation](#).
 - (3) Install 221 BZ - Left Lower Cockpit Sidewall Assembly. Refer to [AMM-25-11-20-041-801 – Cockpit Panels - Installation](#).
 - (4) Install 222 BZ - Right Lower Cockpit Sidewall Assembly. Refer to [AMM-25-11-20-041-801 – Cockpit Panels - Installation](#).
 - (5) Install 221 LZ - Cockpit Headliner. Refer to [AMM-25-11-20-041-801 – Cockpit Panels - Installation](#).
 - (6) Install 131 AZ - Floor Panel, Forward Left Cabin. Refer to [AMM-25-21-30-041-801 – Cabin Floor Panels - Installation](#).
 - (7) Install 132 AZ - Floor Panel, Forward Right Cabin. Refer to [AMM-25-21-30-041-801 – Cabin Floor Panels - Installation](#).
 - (8) Install 131 BZ - Floor Panel, Forward Cabin Center. Refer to [AMM-25-21-30-041-801 – Cabin Floor Panels - Installation](#).
 - (9) Install 131 CZ - Floor Panel, Aft Left Cabin. Refer to [AMM-25-21-30-041-801 – Cabin Floor Panels - Installation](#).
 - (10) Install 131 CZ-A - Floor Panel, Aft Long, Left Cabin (POST MB 500–34–30). Refer to [AMM-25-21-30-041-801 – Cabin Floor Panels - Installation](#).
 - (11) Install 131 CZ-B - Floor Panel, Aft Short, Left Cabin (POST MB 500–34–30). Refer to [AMM-25-21-30-041-801 – Cabin Floor Panels - Installation](#).
 - (12) Install 131 DZ - Floor Panel, Aft Cabin Center. Refer to [AMM-25-21-30-041-801 – Cabin Floor Panels - Installation](#).
 - (13) Install 132 BZ - Floor Panel, Aft Right Cabin. Refer to [AMM-25-21-30-041-801 – Cabin Floor Panels - Installation](#).
 - (14) Install 231 MZ - Baggage Step Panel. Refer to [AMM-25-21-20-041-801 – Cabin Panels - Installation](#).
 - (15) Install 231 NZ - Floor Panel, Baggage Compartment. Refer to [AMM-25-21-30-041-801 – Cabin Floor Panels - Installation](#).
 - (16) Install 241 HZ - Lower Cabin Door Panel Closeout. Refer to [AMM-06-50-00-051-801 – Aircraft Access Panels](#) for access panel location.
 - (17) Install 251 CL - Left Forward Wing-to-Body Fairing. Refer to [AMM-53-11-12-041-801 – Forward Wing to Body Fairing Assembly - Installation](#).

-
- (18) Install 252 BR - Right Forward Wing-to-Body Fairing. Refer to [AMM-53-11-12-041-801 – Forward Wing to Body Fairing Assembly - Installation](#).
 - (19) 251 EL - Left Lower Wing-to-Body Fairing. Refer to [AMM-53-11-11-041-801 – Lower Wing to Body Fairing Assembly - Installation](#).
 - (20) 252 DR - Right Lower Wing-to-Body Fairing. Refer to [AMM-53-11-11-041-801 – Lower Wing to Body Fairing Assembly - Installation](#).
 - (21) Install 251 FL - Left Aft Wing-to-Body Fairing. Refer to [AMM-53-11-13-041-801 – Aft Wing To Body Fairing - Installation](#).
 - (22) Install 252 EL - Right Aft Wing-to-Body Fairing. Refer to [AMM-53-11-13-041-801 – Aft Wing To Body Fairing - Installation](#).
 - (23) Install 511 HB - Left Main Landing Gear Access Panel. Refer to [AMM-06-50-00-051-801 – Aircraft Access Panels](#) for access panel location.
 - (24) Install 612 HB - Outboard Flap Actuator Panel. Refer to [AMM-06-50-00-051-801 – Aircraft Access Panels](#) for access panel location.
 - (25) Install 311 AL - Maintenance Bay Panel. Refer to [AMM-53-40-10-041-801 – Maintenance Bay Panel - Installation](#).
 - (26) Install 321 BT - Vertical Leading Edge. Refer to [AMM-55-30-12-041-801 – Vertical Stabilizer Leading Edge Fairing - Installation](#).
 - (27) Install 321 DB - Vertical Access Panel. Refer to [AMM-55-30-13-041-801 – Vertical Stabilizer Lower Access Panel - Installation](#).
 - (28) Install 331 DT - Upper Overfin Fairing. Refer to [AMM-55-10-12-041-801 – Overfin Fairing - Installation](#).
 - (29) Install 311 EL - Left Pylon Leading Edge. Refer to [AMM-54-30-11-041-801 – Leading Edge Pylon Skin - Installation](#).
 - (30) Install 312 BR - Right Pylon Leading Edge. Refer to [AMM-54-30-11-041-801 – Leading Edge Pylon Skin - Installation](#).
- C. Install the crew seats. Refer to [AMM-25-11-10-041-801 – Cockpit Seat - Installation](#).
 - D. Install the passenger seats. Refer to [AMM-25-21-10-041-801 – Passenger Seat - Installation](#).
 - E. If all other maintenance is complete, return aircraft to service. Refer to [AMM-20-00-02-051-801 – Return To Service \(After Maintenance\)](#).

THIS PAGE INTENTIONALLY LEFT BLANK

10,000 HOUR/10 YEAR INSPECTION

AMM-05-20-30-081-801

1. — TASK REMOVED FROM AMM —

- A. Structural inspection to be accomplished at intervals specified in the Airworthiness Limitations. Refer to [AMM-04-00-00-081-801 – Airworthiness Limitations](#).

THIS PAGE INTENTIONALLY LEFT BLANK

STRUCTURAL INSPECTION

AMM-05-20-50-081-801

1. General

NOTE: Requirements to perform this task outlined in [AMM-04-00-00-081-801 – Airworthiness Limitations](#).

- A. This task gives the procedures to do the structural inspection. The following areas are to be inspected from the outside of the aircraft.

NOTE: The terms used in this checklist are defined in [AMM-05-20-00-081-801 – Scheduled Maintenance Checks](#).

2. Job Setup

SUBTASK AMM-05-20-50-081-921-001

- A. Make aircraft safe for maintenance. Refer to [AMM-20-00-01-051-801 – Make Safe For Maintenance](#).
- B. Remove the forward combination antenna. Refer to [AMM-23-10-11-001-801 – Combination Antenna - Removal](#).
- C. Remove the iridium antenna. Refer to [AMM-23-15-10-001-801 – Iridium Antenna - Removal](#).
- D. Remove the Wi-Fi S-band antenna. Refer to [AMM-23-20-10-001-801 – Wi-Fi S-Band Antenna - Removal](#).
- E. Remove the upper transponder antenna. Refer to [AMM-34-50-22-001-801 – Transponder Antenna - Removal](#).
- F. If installed, remove the skywatch antenna (optional). Refer to [AMM-34-40-61-001-801 – Skywatch \(Traffic Advisory System\) Antenna - Removal](#).
- G. Remove the lower wing to body fairing. Refer to [AMM-53-11-11-001-801 – Lower Wing to Body Fairing Assembly - Removal](#).
- H. Remove the forward wing to body fairing. Refer to [AMM-53-11-12-001-801 – Forward Wing to Body Fairing Assembly - Removal](#).
- I. If necessary, remove the left and right engine. Refer to [AMM-71-03-00-001-801 – Power Plant - Removal](#).
- J. Remove the access panels that follow as necessary:
- 311 CT - Dorsal Fairing. Refer to [AMM-53-40-13-001-801 – Dorsal Fairing - Removal](#).
 - 311 FL - NACA. Refer to [AMM-06-50-00-051-801 – Aircraft Access Panels](#).
 - 311 GL - Left Aft Upper Pylon Skin. Refer to [AMM-54-30-14-001-801 – Aft Upper Pylon Skin - Removal](#).

EFFECTIVITY: ALL

05-20-50

- 311 JL - Left Forward Lower Pylon Skin. Refer to [AMM-54-30-13-001-801 – Forward Lower Pylon Skin - Removal](#).
- 312 CR - NACA. Refer to [AMM-06-50-00-051-801 – Aircraft Access Panels](#).
- 312 DR - Right Aft Upper Pylon Skin. Refer to [AMM-54-30-14-001-801 – Aft Upper Pylon Skin - Removal](#).
- 312 FR - Right Forward Lower Pylon Skin. Refer to [AMM-54-30-13-001-801 – Forward Lower Pylon Skin - Removal](#).
- 321 BT - Vertical Leading Edge. Refer to [AMM-55-30-12-001-801 – Vertical Stabilizer Leading Edge Fairing - Removal](#).
- 331 GB - Lower Overfin Fairing. Refer to [AMM-55-10-12-001-801 – Overfin Fairing - Removal](#).

3. Procedure

SUBTASK AMM-05-20-50-081-211-001

(Refer to [Fig. 1](#) unless otherwise noted.)

- A. Do a Detailed Visual Inspection (DET) of the fuselage and associated structure for general conditions as follows:
- (1) Examine the cockpit structure as follows:
 - (a) Inspect all fasteners that attach the center post (7) to the windshield (8) .
 - (b) Inspect for cracks extending from or next to the fastener holes.
 - (c) Inspect all fasteners that attach the lower sill beam (6) to the windshield (8) .
 - (d) Inspect for cracks extending from or next to the fastener holes.
 - (e) Inspect all fasteners that attach the upper sill beam (9) to the windshield (7) .
 - (f) Inspect for cracks extending from or next to the fastener holes.
 - (g) Inspect all fasteners that attach the side post (5) to the windshield (8) .
 - (h) Inspect for cracks extending from or next to the fastener holes.
 - (i) Inspect all fasteners that attach the cockpit side windows (4) to the cockpit structure.
 - (j) Inspect for cracks extending from or next to the fastener holes.
 - (k) Inspect left side FS 133 ([Fig. 1, Sheet 2](#)) at the junction of LH Frame FS 133 and LH Aft Lower Windshield Beam for cracks, loose fasteners, and evidence of paint or structural cracking.
 - (2) Examine the upper cabin skin as follows:
 - (a) Inspect all of the antenna skin cut outs for cracks.
 - (b) Inspect all of the edges of the window cut outs (13) for cracks.
 - (c) Inspect the edges of the emergency hatch cut out (15) for cracks.
 - (d) Inspect the edges of the passenger door cut out (3) for cracks.

- (e) Inspect all fasteners from FS 133 to FS 232 that attach the cabin skin splice to stringer S1. Refer to (10) and (11) .
 - (f) Inspect for cracks in the skin extending from under or next to the fastener heads.
 - (g) Inspect all fasteners that attach the skin to the aft pressure bulkhead at stringer S2L and S2R. Refer to (16) .
 - (h) Inspect for cracks in the skin extending from under or next to the fastener heads.
 - (i) Inspect the wing attach lug (14) on the aft pressure bulkhead for cracks.
- (3) Examine the lower cabin skin at FS 180 stub frame as follows:
- (a) Inspect all fasteners next to the skin cut outs for the lug (2) .
 - (b) Inspect for cracks in the skin extending from or next to the fastener heads.
 - (c) Inspect the edges of the skin cut outs for cracks.
- (4) Examine the lower cabin skin at FS 203 wing carry through joint as follows:
- (a) Inspect all fasteners next to the skin cut outs for the upper and lower lugs (1) .
 - (b) Inspect for cracks extending from under or next to the fastener heads.
 - (c) Inspect the edges of the skin cut outs for cracks.

SUBTASK AMM-05-20-50-081-211-002

(Refer to Fig. 2 unless otherwise noted.)

A. Do a DET of the empennage structure for general conditions as follows:

- (1) Examine the aft fuselage structure as follows:
- (a) Inspect all fasteners on the clips that attach the pylon engine beam (1) to the aft fuselage.
 - (b) Inspect for cracks extending from under or next to the fastener heads.
 - (c) Inspect all fasteners that attach the engine yoke (2) to the engine and pylon engine beam.
 - (d) Inspect for cracks extending from under or next to the fastener heads.
- (2) Examine the vertical stabilizer structure as follows:
- (a) Inspect all fasteners that attach the vertical stabilizer front spar splice to the dorsal longeron. Refer to (3) .
NOTE: Inspect the area 4 in. below the dorsal longeron and 4 in. forward of the front spar.
 - (b) Inspect for cracks extending from under or next to the fastener heads.
 - (c) Inspect the forward lugs (fitting and spar) (4) and aft lugs (drag strap and spar) (6) that attach the horizontal stabilizer to the vertical stabilizer.
 - (d) Inspect for cracks next to the bushings.
 - (e) Inspect all fasteners that attach the drag fitting (5) to the skin.
 - (f) Inspect for cracks next to the fastener heads.

- (g) Inspect all fasteners that attach the drag strap (6) to the skin.
- (h) Inspect for cracks extending from under or next to the fastener heads.

SUBTASK AMM-05-20-50-081-211-003

(Refer to Fig. 3 unless otherwise noted.)

A. Do a DET of the wing structure for general conditions as follows:

- (1) Examine the wing box structure as follows:
 - (a) Inspect all skin fasteners that attach the leading edge skin to the WS 60 rib (6) .
 - (b) Inspect for cracks extending from under or next to the fastener heads.
 - (c) Inspect all skin fasteners that attach the lift fitting (13) to the wing root rib.
 - (d) Inspect for cracks extending from under or next to the fastener heads.
 - (e) Inspect the lift fitting lug (12) on the front spar for cracks extending from under or next to the bushings.
 - (f) Inspect the upper lug (8) on the main spar for cracks extending from under or next to the bushings.
 - (g) Inspect the lower lug (9) on the main spar for cracks extending from under or next to the bushings.
 - (h) Inspect the aft spar lower lug (7) for cracks extending from under or next to the bushings.
 - (i) Inspect all the fasteners next to the drag clip (10) that attach the upper skin to the wing root rib.
 - (j) Inspect for cracks extending from under or next to the fastener heads.
 - (k) Inspect the lift link lugs (upper and lower) (11) on the drag clip for cracks extending from under or next to the bushings.
- (2) Examine the lower wing skin as follows:
 - (a) Inspect all skin fasteners that attach the lower wing skin to the WS 69 rib (5) and main spar (3) .
 - (b) Inspect for cracks extending from under or next to the fastener heads.
 - (c) Inspect the edges of the main landing gear skin cut out for cracks.
 - (d) Inspect all skin fasteners that attach the lower wing skin to the main and aft spars next to the landing gear skin cutout. Refer to (1) .
 - (e) Inspect for cracks extending from under or next to the fastener heads.
 - (f) Inspect all skin fasteners that attach the lower wing skin to the WS 80 rib (4) .
 - (g) Inspect for cracks extending from under or next to the fastener heads.
 - (h) Inspect the edges of all the access panels (2) inboard of WS 80 skin cut outs for cracks.
 - (i) Inspect for cracks extending from under or next to the fastener holes.

4. **Job Close-Up**

SUBTASK AMM-05-20-50-081-921-002

- A. Remove all tools, equipment and unwanted material from work area.
- B. Install the forward combination antenna. Refer to [AMM-23-10-11-041-801 – Combination Antenna - Installation](#).
- C. Install the iridium antenna. Refer to [AMM-23-15-10-041-801 – Iridium Antenna - Installation](#).
- D. Install the Wi-Fi S-band antenna. Refer to [AMM-23-20-10-041-801 – Wi-Fi S-Band Antenna - Installation](#).
- E. Install the upper transponder antenna. Refer to [AMM-34-50-22-041-801 – Transponder Antenna - Installation](#).
- F. If necessary, install the skywatch antenna. Refer to [AMM-34-40-61-041-801 – Skywatch \(Traffic Advisory System\) Antenna - Installation](#).
- G. Install the lower wing to body fairing. Refer to [AMM-53-11-11-041-801 – Lower Wing to Body Fairing Assembly - Installation](#).
- H. Install the forward wing to body fairing. Refer to [AMM-53-11-12-041-801 – Forward Wing to Body Fairing Assembly - Installation](#).
- I. If necessary, install the left and right engine. Refer to [AMM-71-03-00-041-801 – Power Plant - Installation](#).
- J. Install the access panels that follow as necessary:
 - Install the 311 CT - Dorsal Fairing. Refer to [AMM-53-40-13-041-801 – Dorsal Fairing - Installation](#).
 - Install the 311 FL - NACA. Refer to [AMM-06-50-00-051-801 – Aircraft Access Panels](#).
 - Install the 311 GL - Left Aft Upper Pylon Skin. Refer to [AMM-54-30-14-041-801 – Aft Upper Pylon Skin - Installation](#).
 - Install the 311 JL - Left Forward Lower Pylon Skin. Refer to [AMM-54-30-13-041-801 – Forward Lower Pylon Skin - Installation](#).
 - Install the 312 CR - NACA. Refer to [AMM-06-50-00-051-801 – Aircraft Access Panels](#).
 - Install the 312 DR - Right Aft Upper Pylon Skin. Refer to [AMM-54-30-14-041-801 – Aft Upper Pylon Skin - Installation](#).
 - Install the 312 FR - Right Forward Lower Pylon Skin. Refer to [AMM-54-30-13-041-801 – Forward Lower Pylon Skin - Installation](#).
 - Install the 321 BT - Vertical Leading Edge. Refer to [AMM-55-30-12-041-801 – Vertical Stabilizer Leading Edge Fairing - Installation](#).
 - Install the 331 GB - Lower Overfin Fairing. Refer to [AMM-55-10-12-041-801 – Overfin Fairing - Installation](#).

- K. If all other maintenance is complete, return aircraft to service. Refer to [AMM-20-00-02-051-801 – Return To Service \(After Maintenance\)](#).

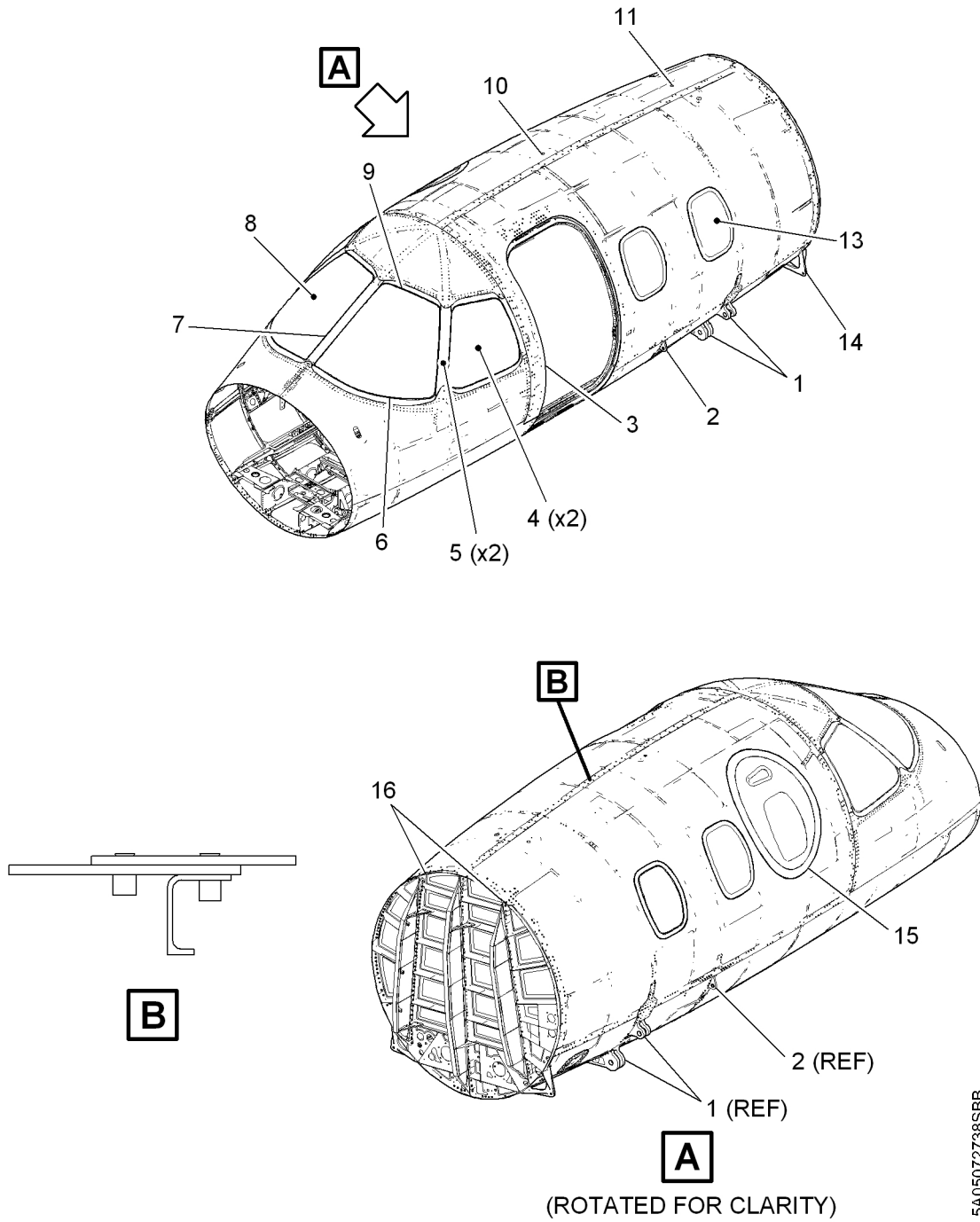

Fuselage Structural Inspection
Figure 1 (Sheet 1 of 2)

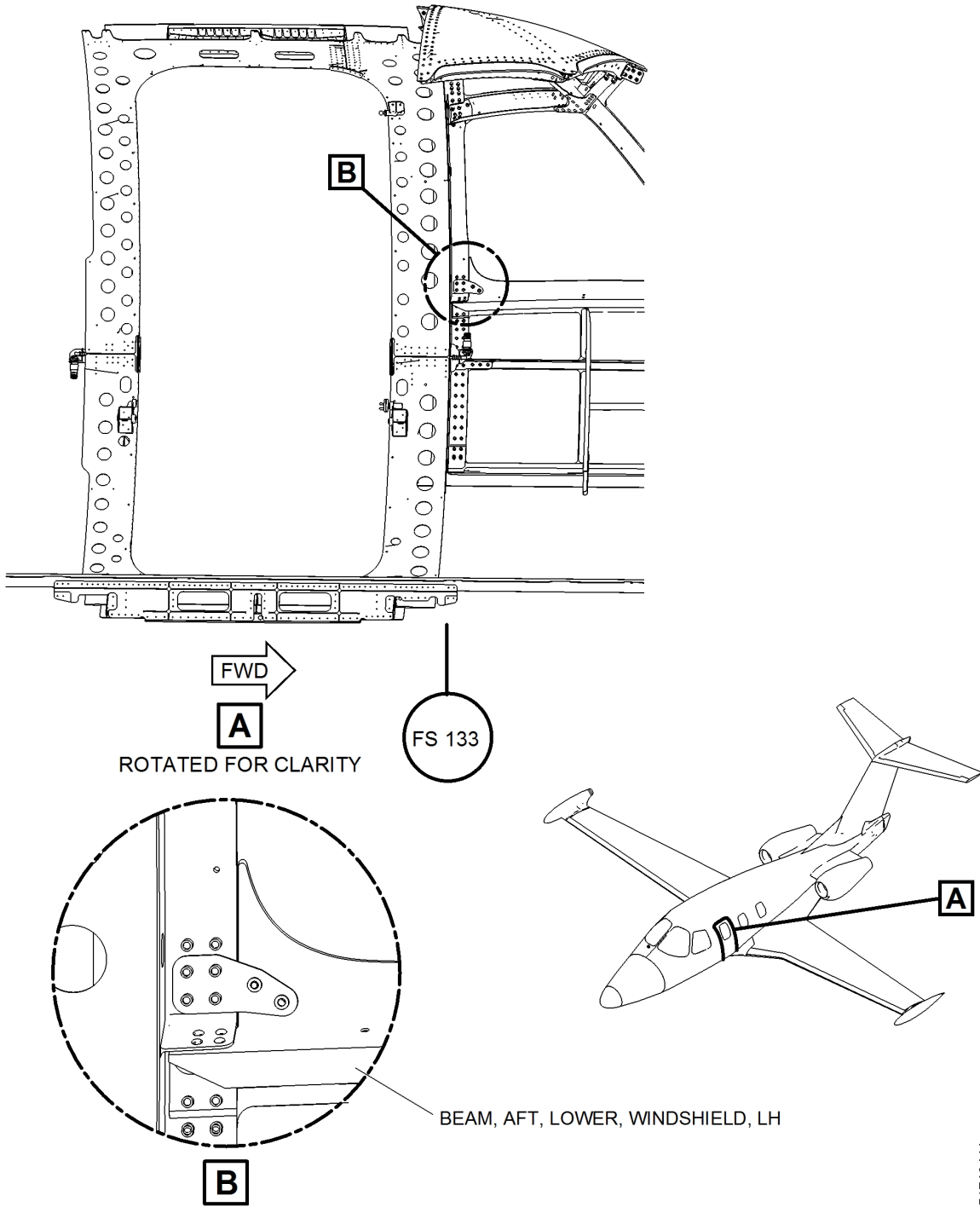

Fuselage Structural Inspection
Figure 1 (Sheet 2 of 2)

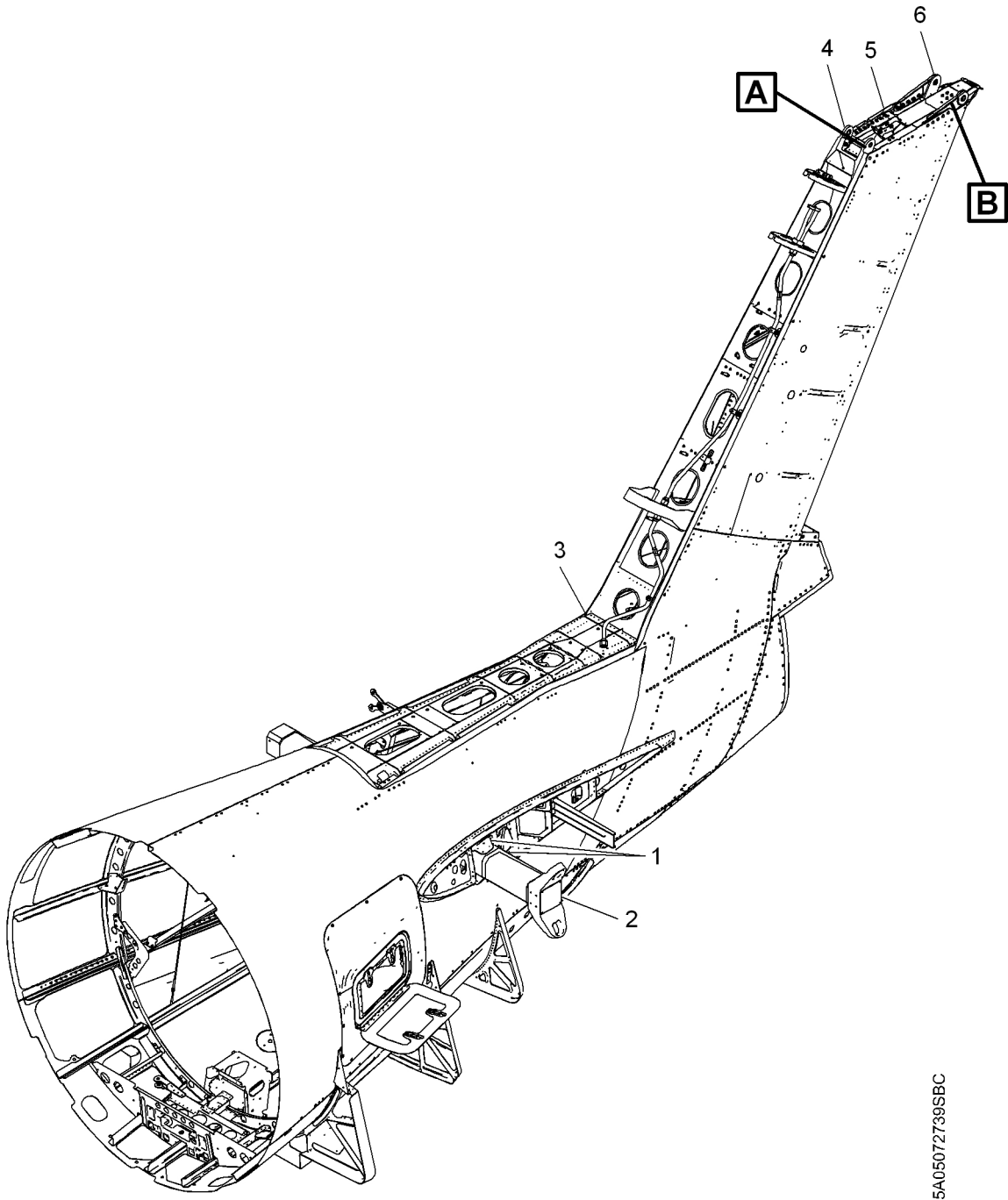

5A05072739SBC

**Empennage Structural Inspection
Figure 2 (Sheet 1 of 2)**

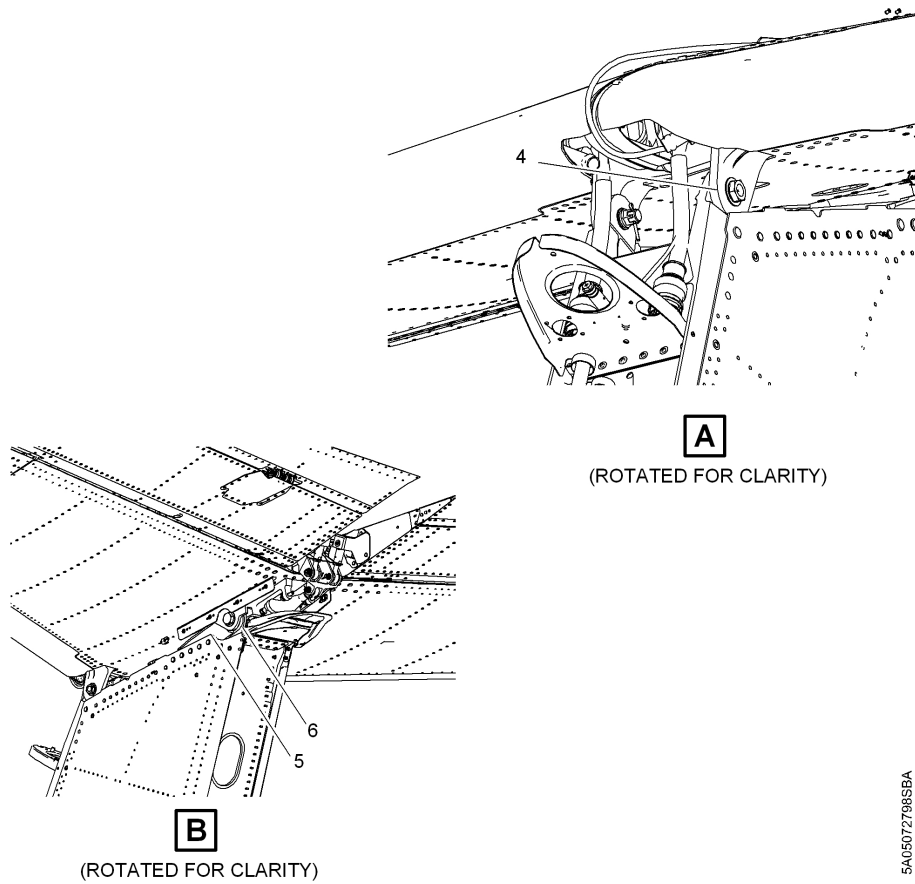

**Empennage Structural Inspection
Figure 2 (Sheet 2 of 2)**

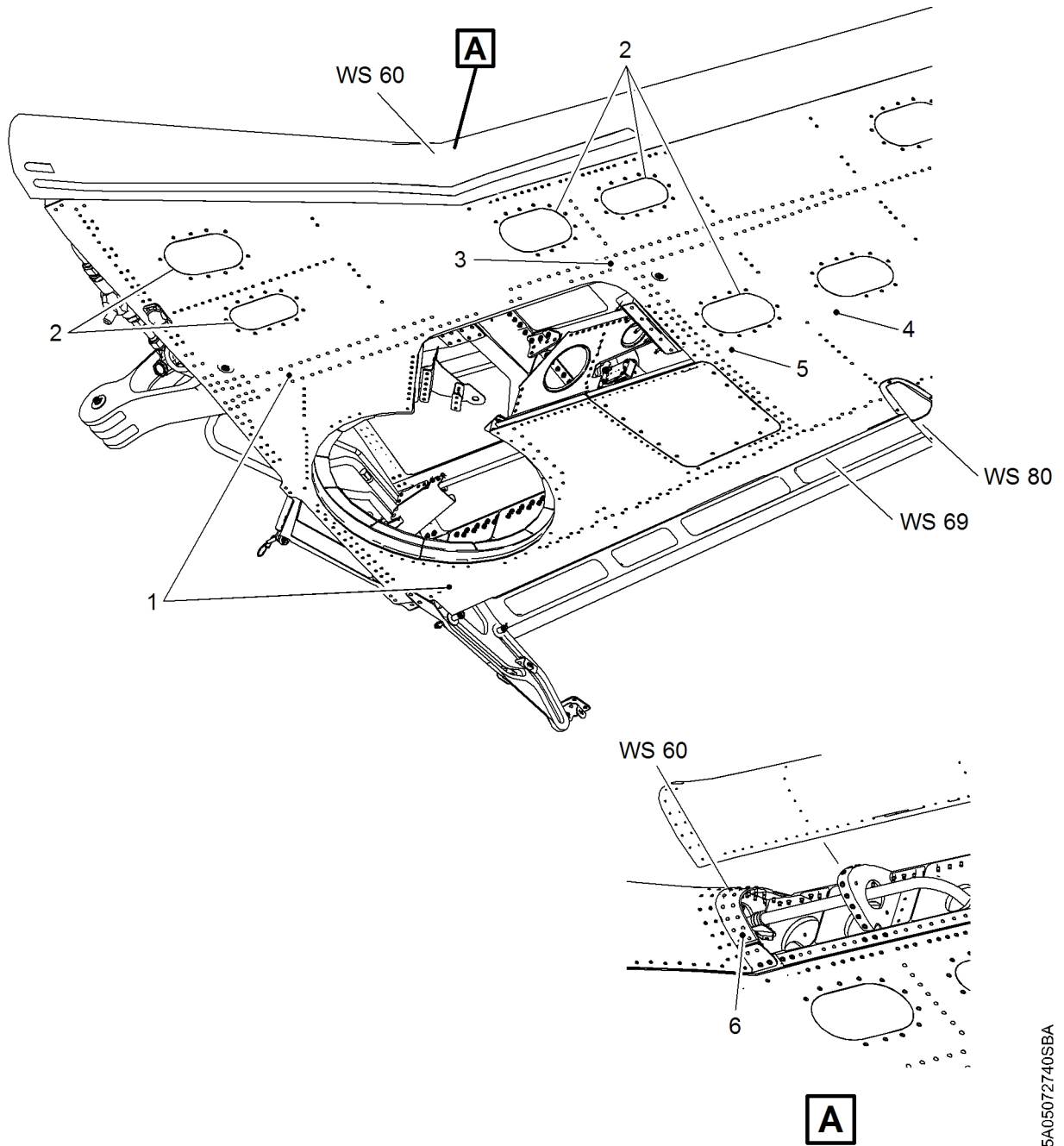

5A05072740SBA

Wing Structural Inspection
Figure 3 (Sheet 1 of 2)

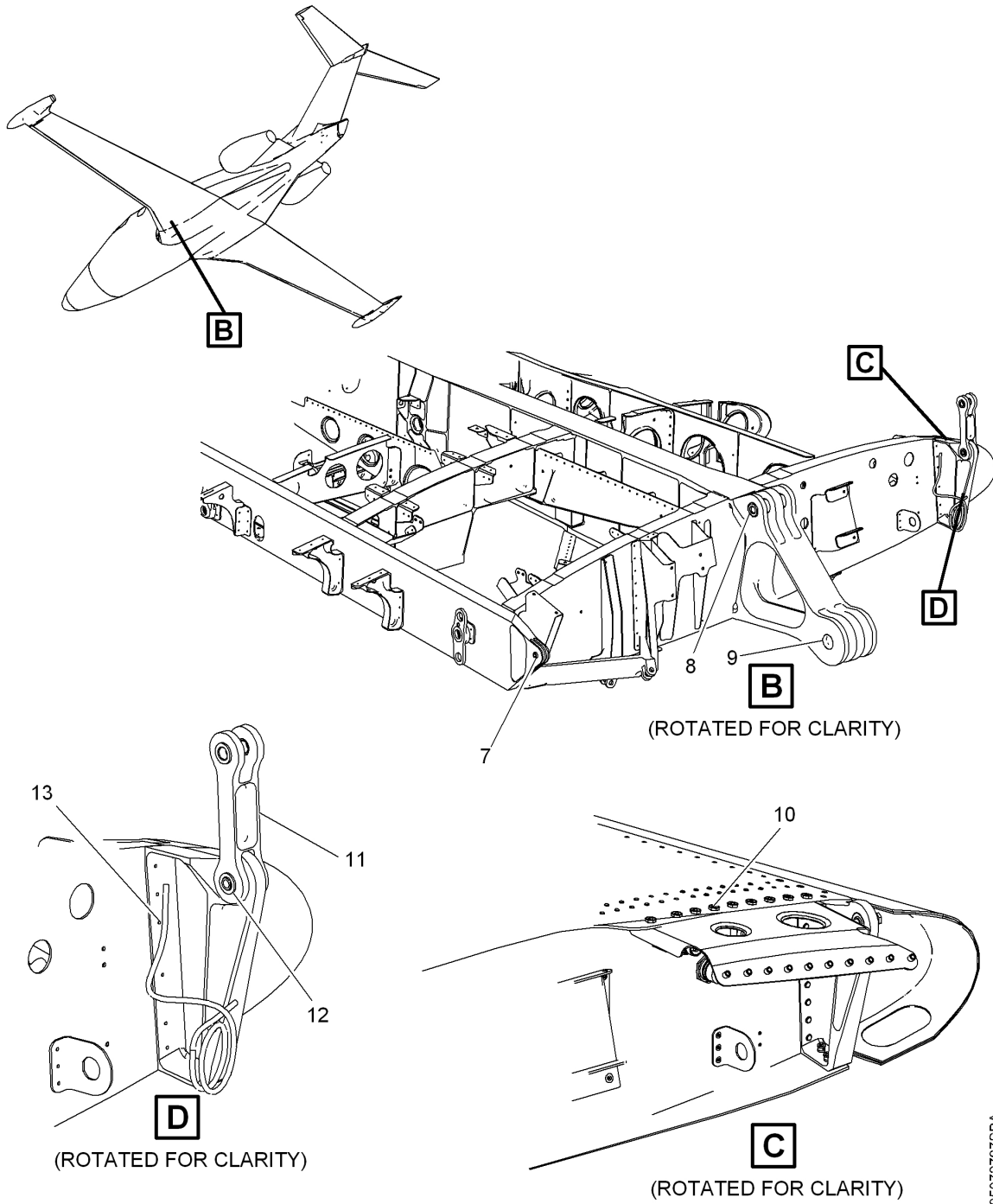

5A05072797SBA

Wing Structural Inspection
Figure 3 (Sheet 2 of 2)

CABIN ZONAL INSPECTION

AMM-05-30-41-021-801

1. General

- A. This task describes the zonal inspection procedures for the cabin zonal inspection.
- B. This inspection is to be done on the components and structures visible with the access listed below.

NOTE: The terms used in the following checklist are defined in [AMM-05-20-00-081-801 – Scheduled Maintenance Checks](#).

- C. This inspection includes lightning/high intensity radiated field (L/HIRF) requirements.

2. Required Access

SUBTASK AMM-05-30-41-021-921-001

- A. Passenger seats removed.
- B. 131 AZ - Floor Panel, Forward Left Cabin. Refer to [AMM-25-21-30-001-801 – Cabin Floor Panels - Removal & AMM-25-21-30-041-801 – Cabin Floor Panels - Installation](#).
- C. 132 AZ - Floor Panel, Forward Right Cabin. Refer to [AMM-25-21-30-001-801 – Cabin Floor Panels - Removal & AMM-25-21-30-041-801 – Cabin Floor Panels - Installation](#).
- D. 131 BZ - Floor Panel, Forward Cabin Center. Refer to [AMM-25-21-30-001-801 – Cabin Floor Panels - Removal & AMM-25-21-30-041-801 – Cabin Floor Panels - Installation](#).
- E. 131 CZ - Floor Panel, Aft Left Cabin. Refer to [AMM-25-21-30-001-801 – Cabin Floor Panels - Removal & AMM-25-21-30-041-801 – Cabin Floor Panels - Installation](#).
- F. 131 CZ-A - Floor Panel, Aft Long, Left Cabin (POST MB 500–34–030). Refer to [AMM-25-21-30-001-801 – Cabin Floor Panels - Removal & AMM-25-21-30-041-801 – Cabin Floor Panels - Installation](#).
- G. 131 CZ-B - Floor Panel, Aft Short, Left Cabin (POST MB 500–34–030). Refer to [AMM-25-21-30-001-801 – Cabin Floor Panels - Removal & AMM-25-21-30-041-801 – Cabin Floor Panels - Installation](#).

NOTE: Remove fasteners only. Leave floor panel in place. The GPS 3 (GDL88 Unit) is attached to the underside of the panel. Inspection can be accomplished by lifting the panel from the forward edge and rotating the panel aft. If removal is required, refer to [AMM-34-50-11-001-C-801 – GPS 3 - Removal](#) and [AMM-34-50-13-001-801 – GPS 3 Mount - Removal](#).

- H. 131 DZ - Floor Panel, Aft Cabin Center. Refer to [AMM-25-21-30-001-801 – Cabin Floor Panels - Removal & AMM-25-21-30-041-801 – Cabin Floor Panels - Installation](#).

EFFECTIVITY: ALL

05-30-41

- I. 132 BZ - Floor Panel, Aft Right Cabin. Refer to
[AMM-25-21-30-001-801 – Cabin Floor Panels - Removal & AMM-25-21-30-041-801 – Cabin Floor Panels - Installation.](#)
- J. 231 NZ - Floor Panel, Baggage Compartment. Refer to
[AMM-25-21-30-001-801 – Cabin Floor Panels - Removal & AMM-25-21-30-041-801 – Cabin Floor Panels - Installation.](#)
- K. 231 MZ - Baggage Step Panel. Refer to
[AMM-25-21-20-001-801 – Cabin Panels - Removal & AMM-25-21-20-041-801 – Cabin Panels - Installation.](#)
- L. 231 NZ - Floor Panel, Baggage Compartment. Refer to
[AMM-25-21-30-001-801 – Cabin Floor Panels - Removal & AMM-25-21-30-041-801 – Cabin Floor Panels - Installation.](#)
- M. 231 KZ - Cabin Oxygen Box Cover. Refer to
[AMM-06-50-00-051-801 – Aircraft Access Panels.](#)
- N. 231 LZ - Cabin Oxygen Box Cover. Refer to
[AMM-06-50-00-051-801 – Aircraft Access Panels.](#)
- O. 231 JZ - Cabin Headliner Assembly. Refer to
[AMM-25-21-20-001-801 – Cabin Panels - Removal & AMM-25-21-20-041-801 – Cabin Panels - Installation.](#)
- P. 232 AZ - Right Upper Sidewall Panel. Refer to
[AMM-25-21-20-001-801 – Cabin Panels - Removal & AMM-25-21-20-041-801 – Cabin Panels - Installation.](#)
- Q. 232 FZ - Right Lower Cabin Sidewall Assembly. Refer to
[AMM-25-21-20-001-801 – Cabin Panels - Removal & AMM-25-21-20-041-801 – Cabin Panels - Installation.](#)
- R. 241 JZ - Upper Door Panel. Refer to
[AMM-25-21-23-001-801 – Upper Door Panel - Removal & AMM-25-21-23-041-801 – Upper Door Panel - Installation.](#)
- S. 231 FZ - Left Upper Sidewall Panel. Refer to
[AMM-25-21-20-001-801 – Cabin Panels - Removal & AMM-25-21-20-041-801 – Cabin Panels - Installation.](#)
- T. 231 AZ - Left Lower Cabin Sidewall Assembly. Refer to
[AMM-25-21-20-001-801 – Cabin Panels - Removal & AMM-25-21-20-041-801 – Cabin Panels - Installation.](#)
- U. 231 PZ - Aft Bulkhead Panel. Refer to
[AMM-25-21-20-001-801 – Cabin Panels - Removal & AMM-25-21-20-041-801 – Cabin Panels - Installation.](#)
- V. 231 HZ - APC/PDC Cover Panel. Refer to
[AMM-25-21-20-001-801 – Cabin Panels - Removal & AMM-25-21-20-041-801 – Cabin Panels - Installation.](#)

3. **Procedure**

SUBTASK AMM-05-30-41-021-211-001

- A. Do a General Visual Inspection (GVI) of the cabin paying particular attention to the following:
- (1) All structure visible under the cabin sidewalls and ceiling for any evidence of damage, distortion or corrosion.
 - (2) All visible structure for any evidence of damage, distortion or corrosion.
 - (3) All wiring/wire bundles for condition and security. Check for proper attachment and clearance from structure and components.
 - (4) All control cables for condition, wear, fraying strands, and security of swage fittings. Check cable runs for pulley wear, proper attachment, security, condition of cable retainers, and clearance from structure and components.
 - (5) All control pushrods, bellcranks, sectors and pulleys for condition and security.
 - (6) Seat rails for general condition and cleanliness.
 - (7) Primary and secondary outflow valves and associated wiring and tubing for condition, security and cleanliness.
 - (8) Emergency extension release mechanism and cable for condition and security.
 - (9) Parking brake valve and cable for condition and security.
 - (10) Cabin passenger oxygen mask containers for condition and security.

THIS PAGE INTENTIONALLY LEFT BLANK