CHAPTER - 21 HIGHLIGHTS
(Summary of Changes)*Revision No. TR21-7 May 20/20*

TO: HOLDERS OF THE AIRCRAFT MAINTENANCE MANUAL (06-117751)

Pages that have been added or revised are summarized below. Remove and insert the affected pages as listed, and enter the above revision number with issue date into the Record of Revisions sheet.

This Temporary Revision incorporates and supersedes previously released temporary revisions for the chapters listed below.

Do not remove this page. Keep it in place as a record of previous changes.

CH/SE/SU Page Block No.	Description of Change
21-30-01 PgBlk 501	Added ADVISORY: CABIN ALT HOLD MODE CAS message. Updated CAS message text.

THIS PAGE INTENTIONALLY LEFT BLANK

CPCS OUTFLOW VALVE - ADJUSTMENT/TEST

AMM-21-30-01-071-801

1. General

- A. This task gives procedures to do a test of Cabin Pressurization Control System (CPCS) outflow valves (OFV) and the Avio Processing Center (APC) pressure sensors.
- B. CPCS outflow valve components are mounted on the forward side of the aft pressure bulkhead, beneath the baggage compartment floor.

2. Job Set-Up

SUBTASK AMM-21-30-01-071-921-001

(Refer to [Fig. 501.](#))

- A. Make aircraft safe for maintenance. Refer to [AMM-20-00-01-051-801 – Make Safe For Maintenance.](#)
- B. Get access to cabin pressurization system components as follows:
 - (1) Remove 231 NZ - Floor Panel, Baggage Compartment. Refer to [AMM-25-21-30-001-801 – Cabin Floor Panels - Removal.](#)
 - (2) Remove 311 AL - Maintenance Bay Panel. Refer to [AMM-53-40-10-001-801 – Maintenance Bay Panel - Removal.](#)
- C. Disconnect tube coupling nut (10) that attaches pressurization tube assembly (11) to aft pressure bulkhead connector (9).
- D. Put protective caps on pressurization tube assembly (11) and aft pressure bulkhead connector (9).
- E. Connect a source of filtered dry nitrogen, or filtered dry (oil-free) compressed air, capable of supplying 20 ± 1 psig (137.90 ± 6.89 kPag), to the primary OFV supply air inlet line (11).
- F. Connect WOW Box to Main Landing Gear electrical connectors 32A07P01 (left) and 32A08P01 (right) and set switches to WOnW (on ground).
- G. Apply external power to aircraft. Refer to [AMM-24-40-00-051-801 – External Power - Maintenance Practices](#) for instructions.
- H. Power up the aircraft by setting the SYS BATT and START BATT switches to ON and the BUS TIE to AUTO. Clear any MASTER WARNINGS/CAUTIONS as needed.

WARNING: THE FOLLOWING CHECK IS PERFORMED WITH WEIGHT-OFF-WHEELS SIMULATED. IF THE PITOT/STATIC HEAT ECBS ARE NOT COLLARED, HARM TO PERSONNEL OR AIR DATA TEST EQUIPMENT MAY OCCUR.

- I. Collar the following:
 - ECB - L PITOT HEAT (BATT Bus)

EFFECTIVITY: ALL

21-30-01

Page 501
May 20/20

- ECB - R PITOT HEAT (R FWD Bus)
 - ECB - L STATIC HEAT (BATT Bus)
 - ECB - L STATIC HEAT (R FWD Bus)
 - ECB - R STATIC HEAT (L FWD Bus)
 - ECB - R STATIC HEAT (R FWD Bus)
 - ECB - STBY PITOT HEAT (BATT Bus)
 - ECB - DEICE MANIFOLD HTR (R AFT Bus)
 - ECB - L WINDSHIELD HEAT (L AFT Bus)
 - ECB - R WINDSHIELD HEAT (R AFT Bus)
 - ECB - L ENG ANTI-ICE VLV (L AFT Bus)
 - ECB - R ENG ANTI-ICE VLV (R AFT Bus)
- J. Slowly apply and maintain 20 ± 1 psig (137.90 ± 6.89 kPag) nitrogen to primary CPCS outflow valve (8) .

NOTE: This setup applies to each test below unless otherwise stated.

3. Test Procedure

SUBTASK AMM-21-30-01-071-781-001

(Refer to [Fig. 501.](#))

A. Do the Ground Dump Test as follows:

- (1) Select WOW box to WOffW (in air).
- (2) On the instrument panel left (IPL), make sure that DUMP is OFF. Observe on the MFD PRESS synoptic page that CABIN DUMP is not illuminated.
- (3) On the MFD PRESS synoptic page, select mode to AUTO. Select LDG ALT to MANUAL and using the left lower inner knob, scroll to set the LANDING ALT to 1000 ft below the airport field elevation. Observe OFV and MFD pressurization page.
 - Make sure the primary and secondary outflow valves (8) and (6) CLOSE.

NOTE: This test may take several minutes to complete.

- (4) Select WOW box to WOnW (on ground).
 - Make sure the primary and secondary outflow valves (8) and (6) OPEN.
 - On the primary outflow valve, make sure that the Built-In Test (BIT) indicator (7) is not illuminated. A red light indicates a failure of the primary outflow valve.

B. Do the Outflow Valve Closed Test as follows:

- (1) On the MFD PRESS synoptic page, select mode to MANUAL and vary the SEL CABIN RATE from 0 to 1000 FPM. Observe MFD pressurization page.
- (2) Select WOW box to WOffW (in air).
- (3) On the IPL, make sure DUMP is OFF.

- Observe on the MFD PRESS synoptic page that CABIN DUMP is not illuminated.
- (4) Use MFD bezel key (2) to set SEL CABIN ALTITUDE to -2000 ft (-609.60 meters) below the local field elevation.
- NOTE: The following may take several minutes to complete.
- Make sure that the primary and secondary outflow valves (8) and (6) CLOSE.
 - On the primary outflow valve, make sure the Built-In Test (BIT) indicator (7) is not illuminated. A red light indicates a failure of the primary outflow valve.
- C. Do the Dump Test as follows:
- (1) On the MFD PRESS synoptic page, select mode to MANUAL and vary the SEL CABIN RATE from 0 to 1000 FPM. Observe MFD pressurization page.
- (2) On the IPL, select DUMP switch (1) to ON.
- NOTE: The following may take several minutes to complete.
- Make sure the MFD PRESS synoptic page shows CABIN DUMP illuminated white (5).
 - Make sure the primary and secondary outflow valves (8) and (6) OPEN.
- (3) On the IPL, select DUMP OFF. Observe the following:
- NOTE: The following may take several minutes to complete.
- Make sure the CABIN DUMP is not illuminated.
 - Make sure the primary and secondary outflow valves (8) and (6) CLOSE.
 - Make sure the primary outflow valve BIT indicator (7) is off.
A red light indicates a failure of the primary outflow valve.
- D. Do the Outflow Valve Open Test as follows:
- (1) On the MFD PRESS synoptic page, select mode to MANUAL and vary the SEL CABIN RATE from 0 to 1000 FPM. Observe MFD pressurization page. Observe MFD pressurization page. Make sure the CABIN DUMP is not illuminated.
- (2) On the MFD PRESS synoptic page, set the SEL CABIN ALTITUDE to 2000 ft above the local elevation. Observe the following:
- NOTE: The following may take several minutes to complete.
- Make sure the primary and secondary outflow valves (8) and (6) OPEN.
 - Make sure the primary outflow valve BIT indicator (7) is off. A red light indicates a failure of the primary outflow valve.
- E. Do the APC Pressure Sensors Test as follows:
- (1) Pull the following circuit breakers:
- ECB - R AIRCRAFT COMPUTER (L FWD Bus)
 - ECB - R AIRCRAFT COMPUTER (R FWD Bus)

-
- (2) Make sure that the LH ACS Cabin ALT, Climb Rate, and Delta-P (dP) are shown on the MFD (not dashed out).
 - (3) Record the LH ACS dP value.
 - (4) Make sure that the dP value does not exceed 0.32 psid.
 - (5) Make sure that no WARNING: CABIN dP HIGH CAS message is shown.
 - (6) Reset the following circuit breakers:
 - ECB - R AIRCRAFT COMPUTER (L FWD Bus)
 - ECB - R AIRCRAFT COMPUTER (R FWD Bus)
 - (7) On the IPL, pull the MECHANICAL CIRCUIT BREAKER - INSTRUMENT PANEL, LEFT: L ACS.
 - (8) Pull the following circuit breaker:
 - ECB - L AIRCRAFT COMPUTER (R FWD Bus)
 - (9) ADVISORY: CABIN ALT HOLD MODE CAS message will appear.
 - (10) Make sure that the RH ACS Cabin ALT, Climb Rate, and Delta-P (dP) are shown on the MFD (not dashed out).
 - (11) Record the RH ACS dP value.
 - (12) Make sure that the dP value does not exceed 0.32 psid.
 - (13) Make sure that no WARNING: CABIN dP HIGH CAS message is shown.
 - (14) Reset the following circuit breakers:
 - ECB - L AIRCRAFT COMPUTER (R FWD Bus)
 - MECHANICAL CIRCUIT BREAKER - INSTRUMENT PANEL, LEFT: L ACS

4. **Job Close-Up**

SUBTASK AMM-21-30-01-071-921-002

(Refer to [Fig. 501](#).)

- A. Reduce the 20 ± 1 psig (137.90 ± 6.89 kPag) pressure source to zero psig.
- B. Select WOW box to WOnW (on ground).
- C. Close the following:
 - ECB - L PITOT HEAT (BATT Bus)
 - ECB - R PITOT HEAT (R FWD Bus)
 - ECB - L STATIC HEAT (BATT Bus)
 - ECB - L STATIC HEAT (R FWD Bus)
 - ECB - R STATIC HEAT (L FWD Bus)
 - ECB - R STATIC HEAT (R FWD Bus)
 - ECB - STBY PITOT HEAT (BATT Bus)
 - ECB - DEICE MANIFOLD HTR (R AFT Bus)
 - ECB - L WINDSHIELD HEAT (L AFT Bus)
 - ECB - R WINDSHIELD HEAT (R AFT Bus)
 - ECB - L ENG ANTI-ICE VLV (L AFT Bus)
 - ECB - R ENG ANTI-ICE VLV (R AFT Bus)
- D. Power down the aircraft by selecting SYS BATT and START BATT to OFF and the BUS TIE to OPEN.
- E. Disconnect the WOW Box and reconnect electrical connectors 32A07P01 (left) and 32A08P01 (right) to the proximity switches at the main landing gear struts.
- F. Remove external power from aircraft. Refer to [AMM-24-40-00-051-801 – External Power - Maintenance Practices](#) for instructions.
- G. Disconnect source of compressed nitrogen from the OFV inlet line (9) . Allow nitrogen to evacuate to atmosphere.
- H. Remove protective caps from pressurization tube assembly (11) and aft pressure bulkhead connector (9) .
- I. Connect pressurization tube assembly (11) tube coupling nut (10) to aft pressure bulkhead connector (9) . Torque tube coupling nut (10) to 40-60 lbf.in (4.5-6.7 Nm).
- J. Make sure that all electrical connectors are installed and secure.
- K. Make sure that the interconnect tubes are installed and properly secure.
- L. Make sure that the static tubes are properly secured with the tie wraps.

- M. Make sure that the clearance between the primary static tube, secondary static tube and the control cables are a minimum of 0.50 in. (12.7 mm).
- N. Remove all tools, equipment, and unwanted material from work area.
- O. Install access panels as follows:
 - (1) Install 231 NZ - Floor Panel, Baggage Compartment. Refer to [AMM-25-21-30-041-801 – Cabin Floor Panels - Installation](#).
 - (2) Install 311 AL - Maintenance Bay Panel. Refer to [AMM-53-40-10-041-801 – Maintenance Bay Panel - Installation](#).
- P. If all other maintenance is complete, return aircraft to service. Refer to [AMM-20-00-02-051-801 – Return To Service \(After Maintenance\)](#).

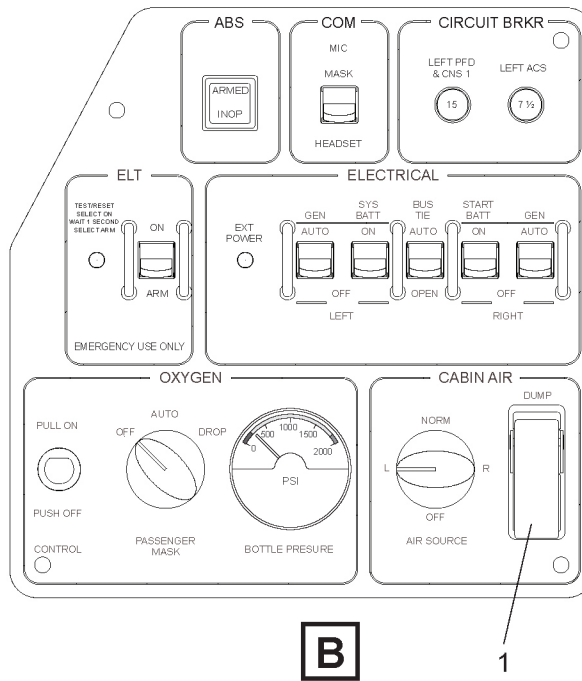
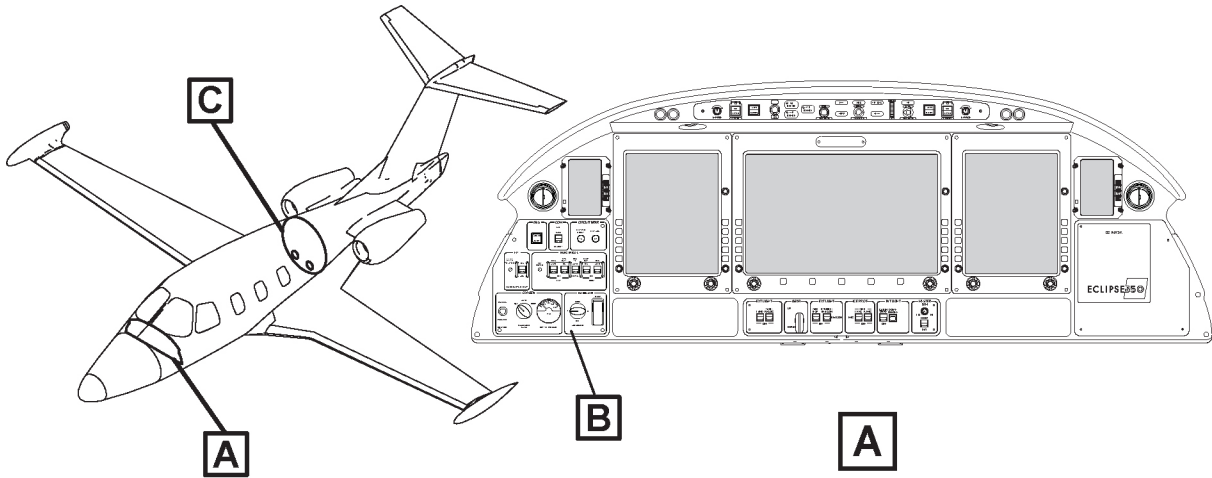

5A210508255BE

CPCS Outflow Valve - Adjustment/Test
Figure 501 (Sheet 1 of 2)

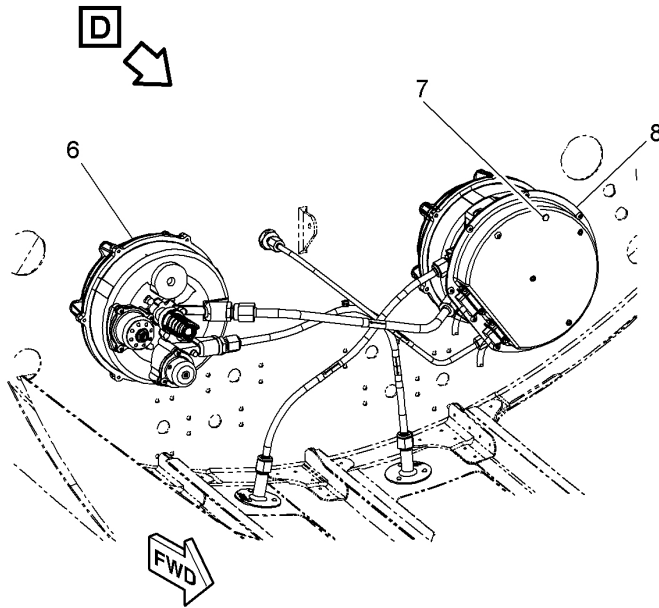

C
(ROTATED FOR CLARITY)

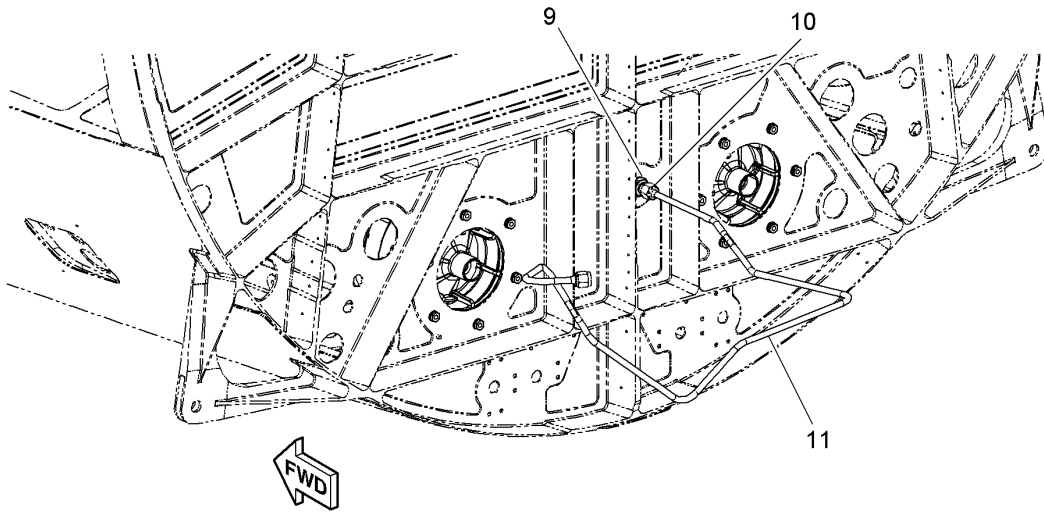

D
(ROTATED FOR CLARITY)

5A21050826SBB

CPCS Outflow Valve - Adjustment/Test
Figure 501 (Sheet 2 of 2)