CHAPTER - 22 HIGHLIGHTS
(Summary of Changes)*Revision No. TR22-4 May 20/20*

TO: HOLDERS OF THE AIRCRAFT MAINTENANCE MANUAL (06-117751)

Pages that have been added or revised are summarized below. Remove and insert the affected pages as listed, and enter the above revision number with issue date into the Record of Revisions sheet.

This Temporary Revision incorporates and supersedes previously released temporary revisions for the chapters listed below.

Do not remove this page. Keep it in place as a record of previous changes.

CH/SE/SU Page Block No.	Description of Change
22-10-11 PgBlk 501	Updated procedure.

THIS PAGE INTENTIONALLY LEFT BLANK

PITCH SERVO CLUTCH - ADJUSTMENT/TEST

AMM-22-10-11-071-801

1. General

- A. This task gives procedures to adjust the pitch servo clutch torque.
- B. There is one pitch servo installed in the aft/tail area.
- C. Unless otherwise stated, references to left and right are with the servo "AS INSTALLED" in the aircraft.

2. Required Equipment and Materials

Table 501. Tools

Description	Specification
Tensiometer, Cable	T-60-1001-C8-1A
Rig pin	0.25 in. (6.35 mm)
Allen Wrench, 0.063 in.	Commercially Available
Spanner Wrench, Capstan	6622-1

3. Job Set-Up

SUBTASK AMM-22-10-11-071-921-001

- A. Make the aircraft safe for maintenance. Refer to [AMM-20-00-01-051-801 – Make Safe For Maintenance](#).
- B. Remove power from the aircraft. Refer to [AMM-24-40-00-051-801 – External Power - Maintenance Practices](#).
- C. Remove the access panels that follow:
 - 251 FL - Left Aft Wing-to-Body Fairing. Refer to [AMM-53-11-13-001-801 – Aft Wing To Body Fairing - Removal](#).
 - 252 EL - Right Aft Wing-to-Body Fairing. Refer to [AMM-53-11-13-001-801 – Aft Wing To Body Fairing - Removal](#).
 - 321 DB - Vertical Access Panel. Refer to [AMM-55-30-13-001-801 – Vertical Stabilizer Lower Access Panel - Removal](#).

EFFECTIVITY: ALL

22-10-11

Page 501
May 20/20

4. Procedure

SUBTASK AMM-22-10-11-071-011-001

(Refer to [Fig. 501.](#))

A. Adjust the pitch servo clutch torque.

- (1) Install a 0.25 in. rig pin through the rig pin hole (2) in the aft elevator sector (1) .
 - (2) Disconnect the autopilot elevator cable assembly (5) from the elevator servo cable, forward - upper (7) and elevator servo cable, aft - upper (6) .
 - (3) Remove the four screws (12) and four washers (13) from the servo end cover (15) .
 - (4) Remove the capstan end cover (15) and the four standoffs (14) .
 - (5) Unlock the cable center ball (16) (1/16th inch set screw) (17) with the allen wrench.
 - (6) Remove the autopilot elevator cable assembly (5) from the pitch servo (3) .
 - (7) Apply electrical power to the aircraft. Refer to [AMM-24-40-00-051-801 – External Power - Maintenance Practices.](#)
-
- (8) On the MFD, use the lower LH/RH knob to scroll to the OPS synoptic page.
 - (9) On the MFD OPS synoptic page, select the SYSTEM TEST LSK.
 - (10) On the MFD OPS SYSTEM TEST synoptic page, use the outer DCK to highlight AUTOFLIGHT.

NOTE: The AUTOFLIGHT test will stop automatically after 2 minutes. If necessary, select the START TEST LSK to start the test again.
 - (11) On the MFD OPS SYSTEM TEST synoptic page, select the START TEST LSK.
 - (a) On the MFD, make sure AUTOFLIGHT TEST IN PROGRESS shows.
 - (12) On the AUTOPILOT CONTROL PANEL (ACP), press the A/P OFF/ON button.
 - (a) On the ACP, make sure the AP OFF/ON LED comes ON.
 - (13) Attach the Capstan Spanner Wrench 6622-1 (2) and torque wrench (1) to the capstan (3) as shown in [Fig. 502.](#)
 - (14) Rotate the Capstan counter-clockwise and measure running torque.

NOTE: Running torque is the value measured while rotating and is not the initial, breakout torque.
 - (15) If the torque is not between 65 and 75 lb.in. (7.34 and 8.47 Nm), adjust the pitch servo torque.
 - (a) To increase the torque value (value is less than 65 lb.in. [7.34 Nm]) rotate the servo center shaft nut CLOCKWISE. Re-measure the torque until the slip clutch torque is between 68 and 72 lb.in. (7.68 and 8.13 Nm).
 - (b) To lower the torque (value is greater than 75 lb.in. [8.47 Nm]), rotate the servo center shaft nut COUNTERCLOCKWISE. Re-measure the torque until the slip clutch torque is between 68 and 72 lb.in. (7.68 and 8.13 Nm).

B. Pitch Servo Clutch Setting — Close-up:

- (1) Remove power from the aircraft. Refer to [AMM-24-40-00-051-801 – External Power - Maintenance Practices](#).

WARNING: MAKE SURE THE BLUE AUTOPILOT ELEVATOR CONTROL CABLE ASSEMBLY IS ON THE AIRCRAFT RIGHT HAND SIDE AND THE PINK AUTOPILOT ELEVATOR CONTROL CABLE ASSEMBLY IS ON THE AIRCRAFT LEFT HAND SIDE DURING INSTALLATION. FAILURE TO OBEY THESE INSTRUCTIONS WILL CAUSE INJURY TO PERSONS AND DAMAGE TO THE AIRCRAFT.

- (2) Align the capstan on servo so the ball groove is at the 12 o'clock position in regard to its mounting position.
- (3) Place the autopilot elevator cable assembly (5) onto the Pitch Servo (3) with the shorter blue terminal end positioned to aircraft left and the longer pink terminal end positioned to aircraft right.
- (4) Align and insert the autopilot elevator cable assembly ball (16) into the ball groove on servo capstan.

CAUTION: FIRMLY PRESS AND HOLD THE CABLE ASSEMBLY BALL IN PLACE DURING INSTALLATION.

- (5) Using an allen wrench, lock the autopilot elevator cable assembly ball (16) in position with the 1/16th inch set screw in the capstan (17).
- (6) Wrap the shorter blue terminal end of the cable 1.75 (one and three-quarters) turns forward.
- (7) Wrap the longer pink terminal end of the cable 1.75 (one and three-quarters) turns aft.
- (8) Hold the autopilot elevator cable assembly (5) in position and install the four standoffs (14).
- (9) Torque the standoffs to between 4 and 5 lb.in. (0.4519 and 0.5649 Nm).
- (10) Put the capstan end cover (15) on the standoffs (14) and align the screw holes.
- (11) Attach the capstan end cap (15) with the four screws (12) and four washers (13).
- (12) Torque the screws to between 4 and 5 lb.in. (0.4519 and 0.5649 Nm).

CAUTION: MAKE SURE NOT TO CROSS THE CABLE ASSEMBLIES.

- (13) Connect the autopilot elevator cable assembly (5) blue terminal end to the elevator servo cable, Fwd - Upper (7) blue terminal end.
- (14) Connect the autopilot elevator cable assembly (5) pink terminal end to the elevator servo cable, Aft - Upper (6) pink terminal end.

NOTE: Make sure the cables are not twisted for the entire length of run.

- (15) Tension the autopilot elevator cable assembly (5) using the turnbuckles on the cable ends to 50 lbs, alternating tightening between both sides to avoid rolling the servo capstan from forward center.

-
- (16) Remove the 0.25 in. rig pin from the aft elevator sector (1).
- (17) Cycle the elevator for 50 cycles to pre-stretch and seat the control cable loop.
- (a) Using the cockpit controls, cycle the elevator for 50 cycles to pre-stretch and seat the control cable loop.
- NOTE:** One cycle is accomplished by starting from the AIRCRAFT FULL NOSE DOWN stop, displacing the control surface to the AIRCRAFT FULL NOSE UP stop and returning to the AIRCRAFT FULL NOSE DOWN stop.
- (18) Install the 0.25 in. rig pin through the rig pin hole (2) in Aft Elevator Sector (1).
- (19) Using the Cable Tensiometer to measure the tension on the autopilot elevator cable assembly (5), adjust the turnbuckles on the cable ends to between 20 and 30 lbs at 70° F (21 deg. C), alternating tightening between both sides to avoid rolling the servo capstan from the forward center position.
- NOTE:** Refer to Fig. 503 for temperature corrections.
- (20) Install the locking clips on the turnbuckle body.
- (21) Remove the 0.25 in. rig pin from the aft elevator sector (1).
- (22) Apply power to the aircraft. Refer to [AMM-24-40-00-051-801 – External Power - Maintenance Practices](#).
- (23) On the MFD, select the PROCEED LSK.
- (24) On the MFD, use the lower LH/RH knob to scroll to the ECB synoptic page.
- (25) On the MFD ECB synoptic page, select the ECB BY SYSTEM LSK.
- (26) On the MFD ECB synoptic page, use the inner DCK to select the FLCS system, and the outer DCK to highlight the ECB that follows:
- ECB - AP ELEVATOR SERVO (R FWD Bus)
- (27) On the MFD ECB synoptic page, select the RESET LSK.
- (a) On the MFD ECB synoptic page, make sure the ECB that follows shows as AUTO/ON:
- ECB - AP ELEVATOR SERVO (R FWD Bus)
 - ECB - AP AILERON SERVO (R FWD Bus)
 - ECB - AP RUDDER SERVO (R FWD Bus)
- (28) Do a test of the autopilot. Refer to [AMM-22-00-00-071-801 – Auto Flight System - Adjustment/Test](#).

5. **Job Close-Up**

SUBTASK AMM-22-10-11-071-921-002

- A. Remove all tools, equipment, and unwanted material from the work area.
- B. Install the access panels that follow:
 - 321 DB - Vertical Access Panel. Refer to [AMM-55-30-13-041-801 – Vertical Stabilizer Lower Access Panel - Installation](#).
 - 251 FL - Left Aft Wing-to-Body Fairing and 252 EL - Right Aft Wing-to-Body Fairing. Refer to [AMM-53-11-13-041-801 – Aft Wing To Body Fairing - Installation](#).
 - 252 EL - Right Aft Wing-to-Body Fairing. Refer to [AMM-53-11-13-001-801 – Aft Wing To Body Fairing - Removal](#).
- C. If all other maintenance is complete, return the aircraft to service. Refer to [AMM-20-00-02-051-801 – Return To Service \(After Maintenance\)](#).

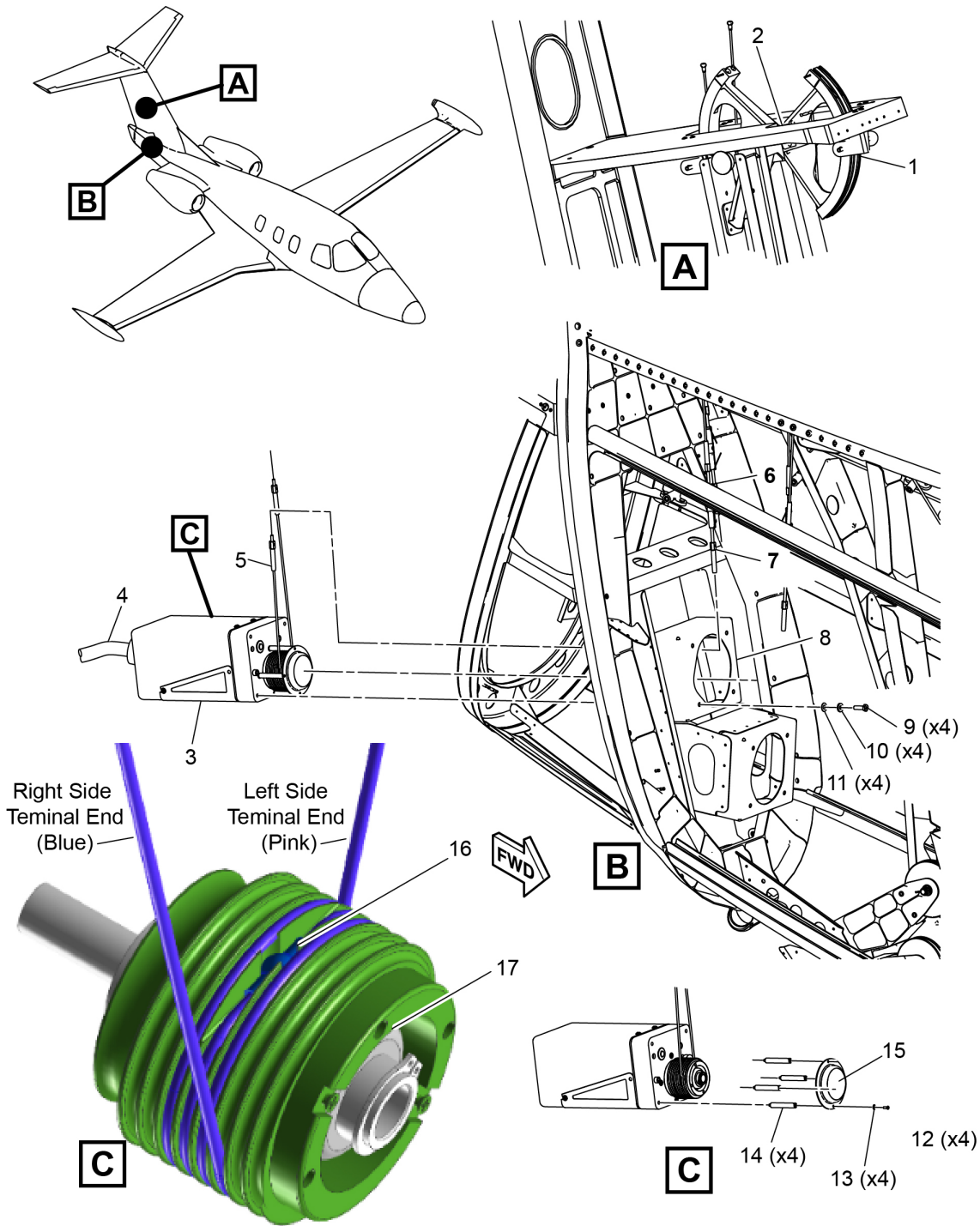

5A22051086SBC

Pitch Servo Clutch - Adjustment/Test
Figure 501 (Sheet 1 of 1)

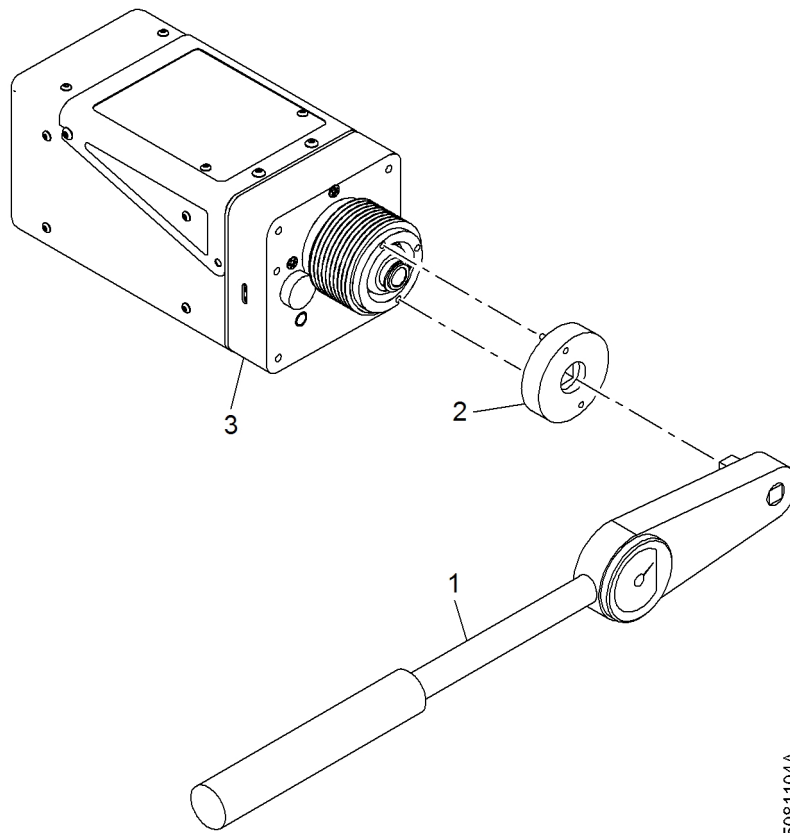

Pitch Servo Clutch - Adjustment/Test
Figure 502 (Sheet 1 of 1)

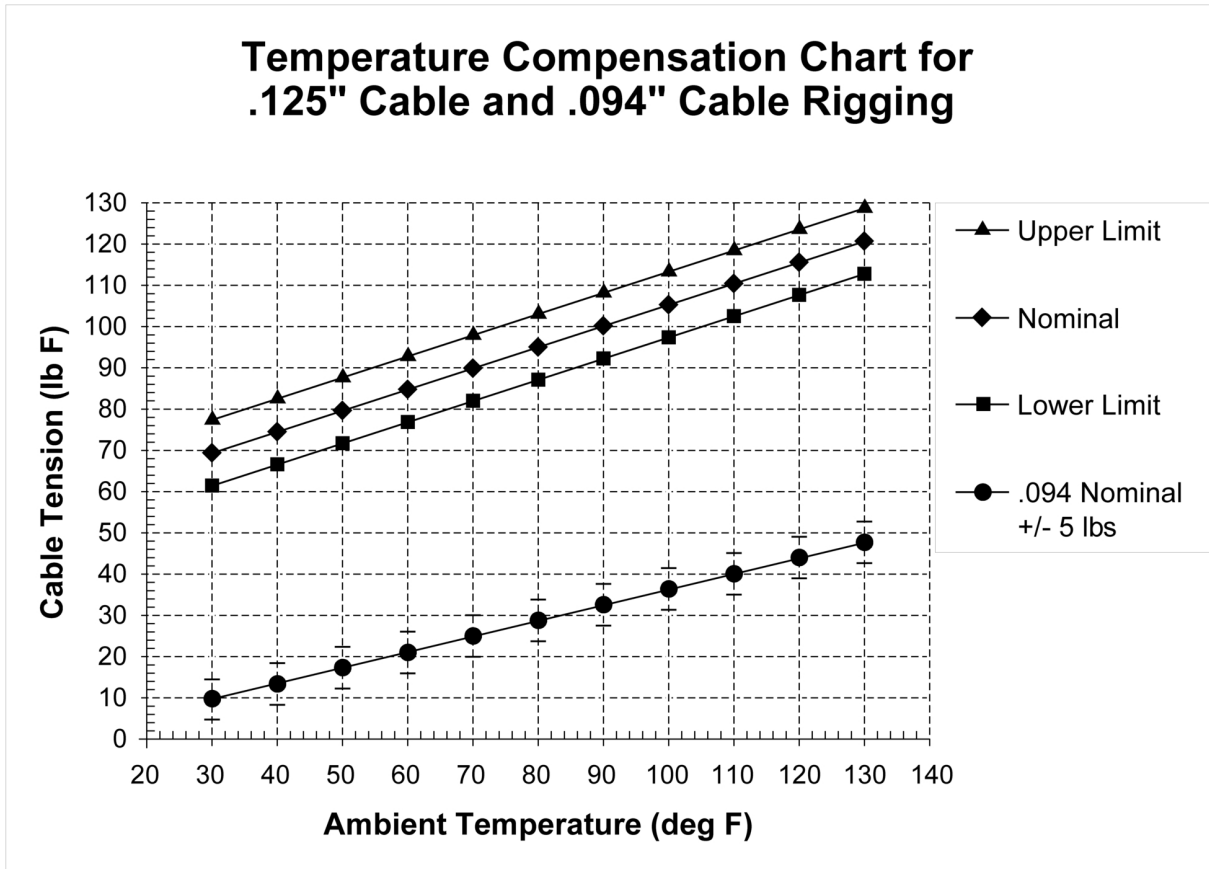

5A27050485SBB

**Elevator Control Cable Temperature Correction Chart
Figure 503 (Sheet 1 of 1)**