CHAPTER - 24 HIGHLIGHTS
(Summary of Changes)*Revision No. TR24-11 Dec 21/18*

TO: HOLDERS OF THE AIRCRAFT MAINTENANCE MANUAL (06-117751)

Pages that have been added or revised are summarized below. Remove and insert the affected pages as listed, and enter the above revision number with issue date into the Record of Revisions sheet.

This Temporary Revision incorporates and supersedes previously released temporary revisions for the chapters listed below.

Do not remove this page. Keep it in place as a record of previous changes.

CH/SE/SU Page Block No.	Description of Change
24-60-00 PgBlk 1 (D)	Independent Pitot/AOA Auxiliary Heaters – Config D.
24-60-13 PgBlk 401-Rem	Updated effectivity to include MB 500-34-028.
24-60-13 PgBlk 401-Inst	Updated effectivity to include MB 500-34-028.

THIS PAGE INTENTIONALLY LEFT BLANK

DC ELECTRICAL LOAD DISTRIBUTION - DESCRIPTION AND OPERATION

AMM-24-60-00-081-D-801

1. Introduction

A. When the engines are running, power is supplied to the aircraft from a Starter Generator (SG) attached to each engine. Power is supplied to the left and right electrical buses through a Forward and an Aft Power Distribution Center. Refer to [Fig. 1, Sheet 1](#).

(1) The DC electrical load distribution system has the components that follow:

- One Forward Power Distribution Center (FPDC)
- One Aft Power Distribution Center (APDC)
- Two Electronic Circuit Breaker Units (ECBU)
- One Fuse Assembly for the Pitot/AOA Probe Auxiliary Heaters. Refer to [Fig. 1, Sheet 2](#).

2. Description

SUBTASK AMM-24-60-00-081-D-871-001

*** ALL POST MB 500-34-028

A. Forward Power Distribution Center (FPDC)

(1) The FPDC LRU is located in the forward section of the aircraft inside the pressure bulkhead, behind the instrument panel.

B. Aft Power Distribution Center (APDC)

(1) The APDC is installed in the aft left side of the aircraft inside the pressure bulkhead.

C. Electronic Circuit Breaker Unit (ECBU)

(1) Two identical ECBUs are installed in the forward section of the aircraft inside the pressure bulkhead behind the instrument panel.

D. Fuse Assembly for the Pitot/AOA Probe Auxiliary Heaters

(1) The Fuse Assembly for the Pitot/AOA Probe Auxiliary Heaters is located below the Aft Power Distribution Center (APDC), connected to electrical connector 24A04P01.

3. Operation

SUBTASK AMM-24-60-00-081-D-871-002

*** ALL POST MB 500-34-028

A. Forward Power Distribution Center:

(1) The FPDC contains the power distribution components for the left (ECBU1) and right (ECBU2) buses. The ECBUs are separate Line Replaceable Units (LRU). The FPDC contains the components that follow:

- ECBU3

- Left Battery Bus Contactor (LBBC)
 - Right Battery Bus Contactor (RBBC)
 - Systems Battery current reporting and ground fault detection circuitry
 - Start Battery current reporting and ground fault detection circuitry
- (2) The Left Battery Bus Contactor (LBBC) is used to electrically connect or separate the left forward and battery buses. the LBBC is controlled by the ACS through a RS-485 data bus.
 - (3) The left forward bus is supplied from the Left Forward Remote Electronic Circuit Breaker (LFRECB) in the APDC. This bus uses ECBU No. 1 and ECBU No. 3 to supply power to the aircraft equipment in normal operation.
 - (4) The right forward bus is supplied from the Right Forward Remote Electronic Circuit Breaker (RFRECB) in the APDC. This bus uses ECBU2 to supply power to the aircraft equipment in normal operation. The Right Battery Bus Contactor (RBBC) is used to electrically connect or separate the right forward and battery bus. The RBBC is controlled by the Aircraft Computer System (ACS) through a RS-485 data bus.
 - (5) The systems battery ground fault protection function is provided by a current sensor in the Battery Bus Contactor (BBC) and a detection and logic function in the FPDC. The BBC monitors systems battery current and provides a current source output signal that is proportional to the systems battery current. The FPDC measures the amplitude of that signal and senses a ground fault if the current is more than a specified maximum. The systems battery ground fault status is reported to the ACS through the RS-485 data bus.
 - (6) The start battery ground fault protection function is provided by a current sensor in the Start Battery Contactor/Lighting Controller (SBCLC or SBC/LC) and a detection and logic function in the FPDC. The SBCLC monitors start battery current and provides a current source output signal that is proportional to the start battery current. The FPDC measures the amplitude of that signal and senses a ground fault if the current more than a specified maximum. The start battery ground fault status is reported to the ACS through the RS-485 data bus.
 - (7) ECBU3 monitors the left forward, battery, and right forward bus voltages, and the ECB current for equipment connected to these buses. The ECBs are programmable within a specified range of current. Each ECB contains a solid-state switch, current protection and built-in test functions, and voltage and current monitoring capabilities. The ECBs have immediate and I2T current protection features.
 - (8) Refer to [Table 1](#) for ECB Quantity by Programmable Range.

Table 1. ECBU3 ECB Quantity by Programmable Range

ECBU No. 3	ECB Program Values
4	2.5A
5	2.5, 5.0, 7.5A
1	7.5, 10, 15A

B. Aft Power Distribution Center:

- (1) The APDC contains the power distribution components for the left and right aft buses. The buses are separated by a barrier in the APDC. A Bus Tie Contactor (BTC) is used to electrically connect and separate the buses.
 - (2) The APDC contains the components that follow for the left aft bus:
 - ECBU4
 - BTC
 - Left Forward Remote Electronic Circuit Breaker (LFRECB)
 - Left feeder current sensor and differential ground fault detector
 - (3) The APDC contains the components that follow for the right aft bus:
 - ECBU5
 - Right Forward Remote Electronic Circuit Breaker (RFRECB)
 - Right feeder current sensor and differential ground fault detector
 - (4) The left aft bus uses ECBU4 to supply power to the aircraft equipment.
 - (5) The right aft bus uses ECBU5 to supply power to utilization equipment.
 - (6) The LFRECB controls power to the left forward bus and RFRECB controls power to the right forward bus. The ACS controls each Remote Electronic Circuit Breaker (RECB) through the RS-485 data bus. The BTC is used to electrically tie together or separate the left and right aft buses. The BTC is controlled by the ACS through the RS-485 data bus when the BUS TIE switch on the Instrument Panel, Left (IPL), is in the AUTO position. When the BUS TIE switch is in the OPEN position, the BTC is open and can not be closed by the ACS.
 - (7) ECBU4 and ECBU5 monitor the left aft and right aft bus voltages, and the ECB current for equipment connected to these buses. The ECBs are programmable within a specified range of current. Each ECB contains a solid-state switch, current protection and built-in test functions, and voltage and current monitoring capabilities. The ECBs have immediate and I2T current protection features.
- Refer to [Table 2](#) for ECB Quantity by Programmable Range.

Table 2. ECBU4 & ECBU5 ECB Quantity by Programmable Range

ECBU4	ECBU5	ECB Program Values
14	14	2.5A
9	10	2.5, 5.0, 7.5A
5	7	7.5, 10, 15A
5	2	15, 20, 25A
2	1	25, 30A

C. Electronic Circuit Breaker Units:

- (1) ECBU1 distributes power to the aircraft equipment connected to the left forward bus. It receives power from the LFRECB, located in the APDC.
- (2) ECBU2 distributes power to the aircraft equipment connected to the right forward bus. It receives power from the RFRECB, located in the APDC.
- (3) ECBU1 and ECBU2 contain ECBs that are programmable within a specified range of current. Each ECB contains a solid-state switch, current protection and built-in test functions, and voltage and current monitoring capabilities. The ECBs have immediate and I2T current protection features. Refer to [Table 3](#) for ECB Quantity by Programmable Range.
- (4) There are five ECBUs. Each ECBU is associated with one of the following five buses in the aircraft.
 - ECBU1: Left forward bus
 - ECBU2: Right forward bus
 - ECBU3: Battery bus
 - ECBU4: Left aft bus
 - ECBU5: Right aft bus
- (5) Each ECBU contains a number of ECBs. The ECBs supply power to individual systems or loads. Each ECB provides fault protection for the load circuit wiring that is supplied by that ECB. The ECB will automatically trip in the event of a wiring fault or overload. Reset may be attempted by way of pilot input at the Multifunction Display (MFD). The ECBs will trip in the event of circuit fault regardless of the presence of a command to close from the pilot. Automatic reset after a fault is cleared is not allowed. In addition, the ACS controls the ECBUs as necessary to control systems operation and load shedding. ECBU control by the ACS is by way of dual RS-485 data buses. The ACS controls required load shedding in the event of loss of one or both SGs.

Table 3. ECBU1 & ECBU2 ECB Quantity by Programmable Range

ECBU1	ECBU2	ECB Program Values
13	13	2.5A
7	7	2.5, 5.0, 7.5A
4	4	7.5, 10, 15A

D. ECBs:

Circuit protection is provided by 127 ECBs that are controlled by the ACS. Each of the ECBs contains an independent microprocessor that detects over-current conditions and is programmed to operate the same way a mechanical breaker operates (trips faster if a larger ratio of over-current occurs). Each ECB is also monitored by the adjacent microprocessor, so that the reliability of the ECB is higher than the mechanical circuit breaker it replaces. The status of each ECB may be displayed on the Multifunction Display (MFD) and is remembered by the ECB in non-volatile memory. Thus, when the aircraft is powered down and then back up, the prior state of the ECB is returned. All

circuits that were turned on at the time the power was removed are again turned on when power is reapplied. Two mechanical circuit breakers supply power to the left PFD and left ACS to make sure that no transitory event can cause all the ECBs to turn off and thus remove all computer control to turn them back on.

- (1) Each ECBU contains a number of ECBs. The ECBs supply power to individual systems or loads. Each ECB provides fault protection for the load circuit wiring that is supplied by that ECB. The ECB will automatically trip in the event of a wiring fault or overload. Reset may be attempted by way of pilot input at the MFD. The ECBs will trip in the event of circuit fault regardless of the presence of a command to close from the pilot. Automatic reset after a fault is cleared is not allowed. In addition, the ACS controls the ECBUs as necessary to control systems operation and load shedding. ECBU control by the ACS is by way of dual RS-485 data buses. The ACS controls require load shedding in the event of loss of one or both SGs.
- E. Pitot/AOA Probe Auxiliary Heaters Fuse Assembly :
- (1) The Pitot/AOA Probe Auxiliary Heaters Fuse Assembly provides circuit protection for the Pitot/AOA Auxiliary Heaters. Power is received from the Aft Power Distribution Center (APDC), ECBU #4 (L AFT Bus) through three 5 Amp fuses, one fuse for each heater and one fuse for the Pitot/AOA Auxiliary Heater Switch and Fail Indicator and Auxiliary Heater Controller. Power for each Pitot/AOA Auxiliary Heater is switched on and off by the Auxiliary Heater Controller.

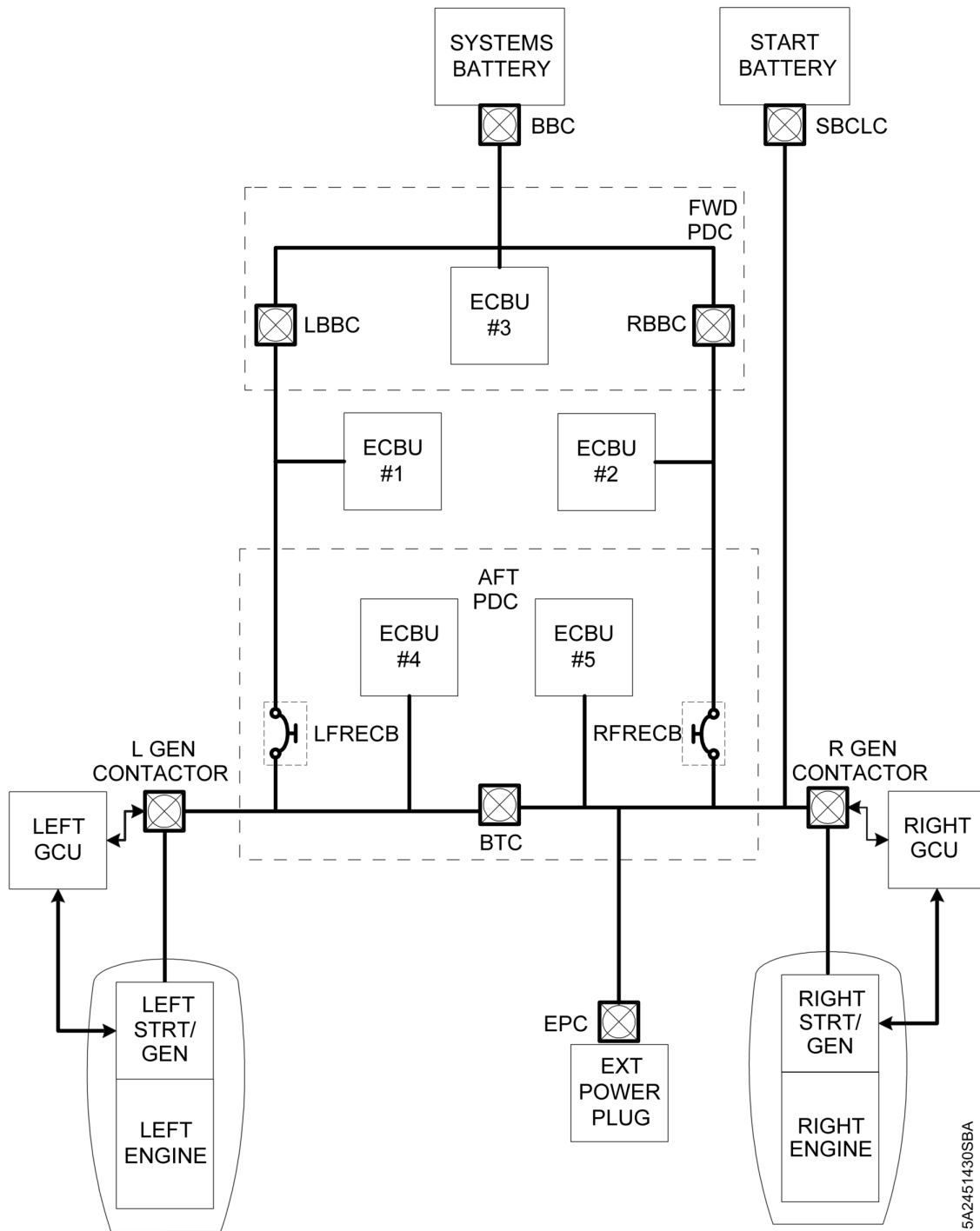

DC Electrical Load Distribution - Description and Operation
Figure 1 (Sheet 1 of 2)

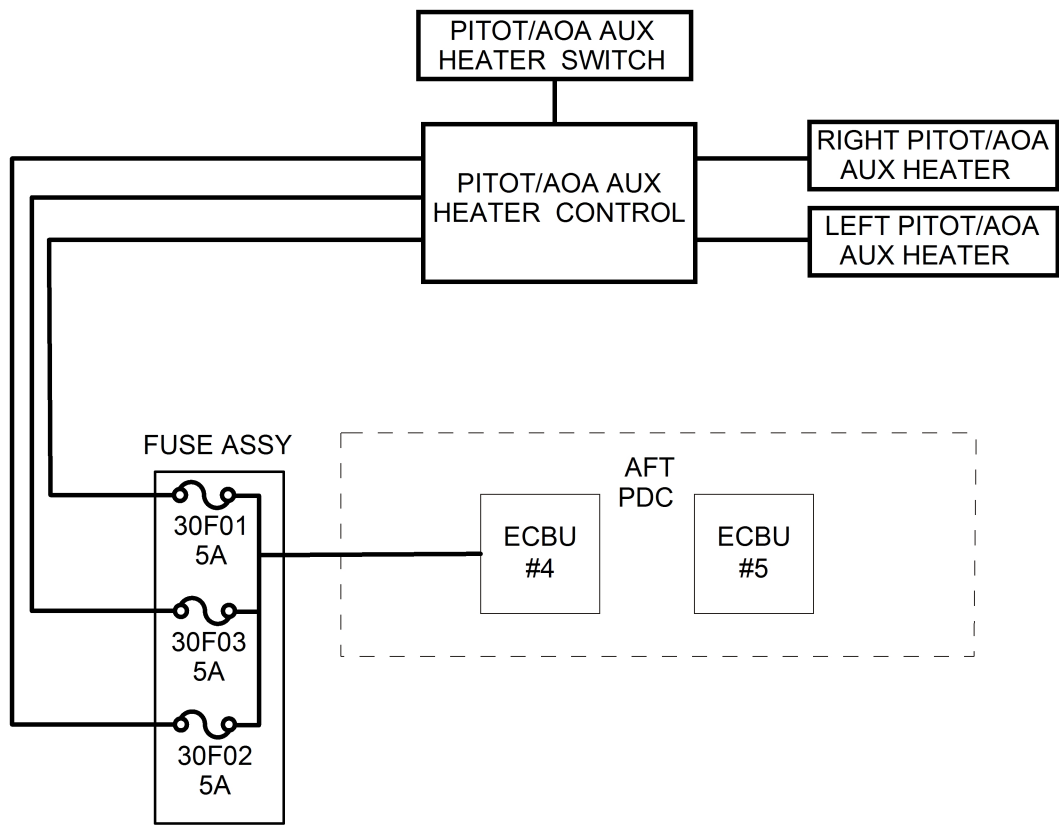

5171954A

DC Electrical Load Distribution - Description and Operation
Figure 1 (Sheet 2 of 2)

THIS PAGE INTENTIONALLY LEFT BLANK

PITOT/AOA PROBE AUXILIARY HEATER FUSE ASSEMBLY - REMOVAL

AMM-24-60-13-001-801

1. General

- A. This task gives the procedures to remove the Auxiliary Heater Fuse Assembly.

2. Job Set-Up

SUBTASK AMM-24-60-13-001-921-001

- A. Make the aircraft safe for maintenance. Refer to [AMM-20-00-01-051-801 – Make Safe For Maintenance](#).
- B. Remove the 231 HZ - APC/PDC Cover Panel. Refer to [AMM-06-50-00-051-801 – Aircraft Access Panels](#).

3. Procedure

SUBTASK AMM-24-60-13-001-011-001

(Refer to [Fig. 401](#) .)

- A. Remove tie straps from fuse assembly (1) .
- B. Loosen two screws and remove fuse assembly (1) from electrical connector 30F01J01 (2) .

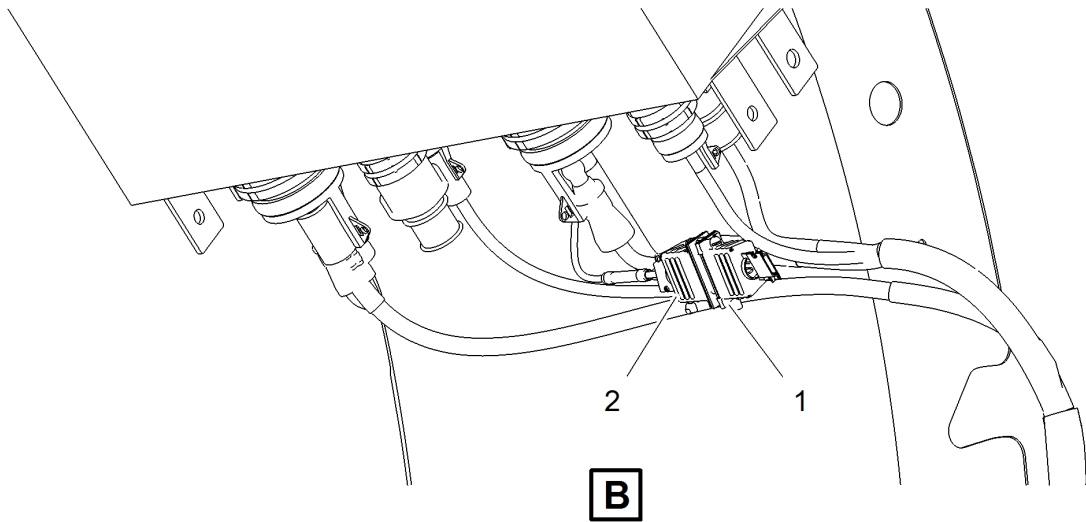
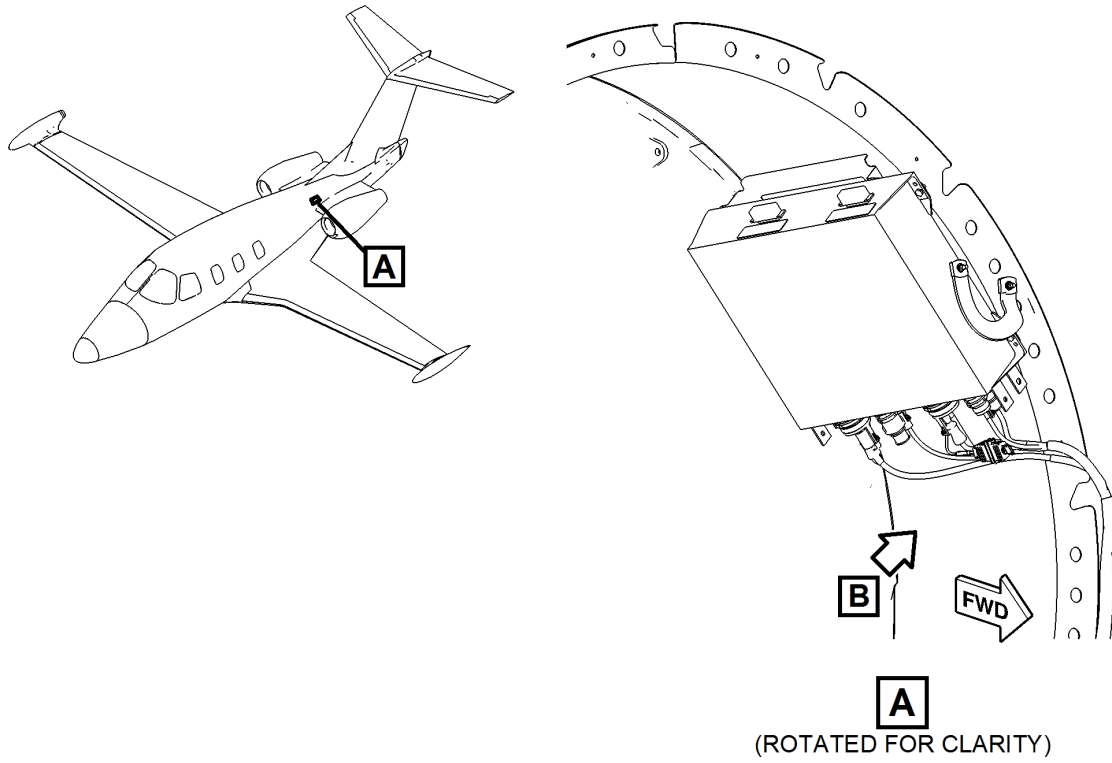

5171941A

Pitot/AOA Probe Auxiliary Heater Fuse Assembly - Removal/Installation
Figure 401 (Sheet 1 of 1)

PITOT/AOA PROBE AUXILIARY HEATER FUSE ASSEMBLY - INSTALLATION

AMM-24-60-13-041-801

1. General

- A. This task gives the procedures to install the Auxiliary Heater Fuse Assembly.

2. Job Set-Up

SUBTASK AMM-24-60-13-041-921-001

(Refer to [Fig. 401, Sheet 1.](#))

- A. Make sure aircraft is in the same configuration as it was when the removal task was completed. Refer to [AMM-24-60-13-001-801 – Pitot/AOA Auxiliary Heater Fuse Assembly - Removal](#)

3. Procedure

SUBTASK AMM-24-60-13-041-411-001

(Refer to [Fig. 401, Sheet 1](#) and [Fig. 401, Sheet 1.](#))

- A. Install fuse assembly (1) on to electrical connector 30F01J01. (2)
- B. Tighten two screws that secure fuse assembly (1) to electrical connector 30F01J01 (2).
- C. Secure fuse assembly (1) to wiring harness 39-108859 using tie straps

4. Job Close-Up

SUBTASK AMM-24-60-13-041-921-002

- A. Install the 231 HZ - APC/PDC Cover Panel. Refer to [AMM-06-50-00-051-801 – Aircraft Access Panels.](#)
- B. Remove all tools, equipment and unwanted material from the work area.
- C. If all other maintenance is complete, return the aircraft to service. Refer to [AMM-20-00-02-051-801 – Return To Service \(After Maintenance\).](#)

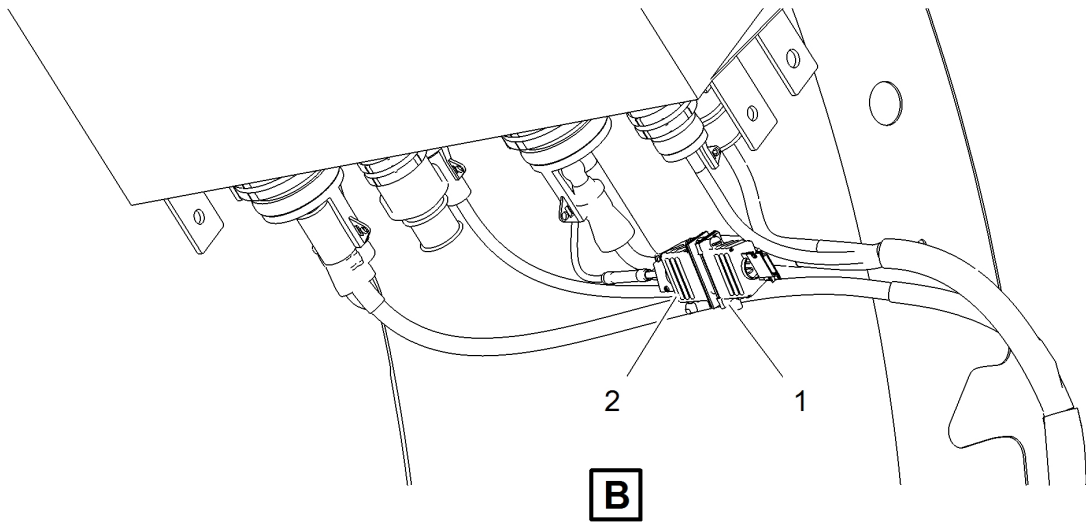
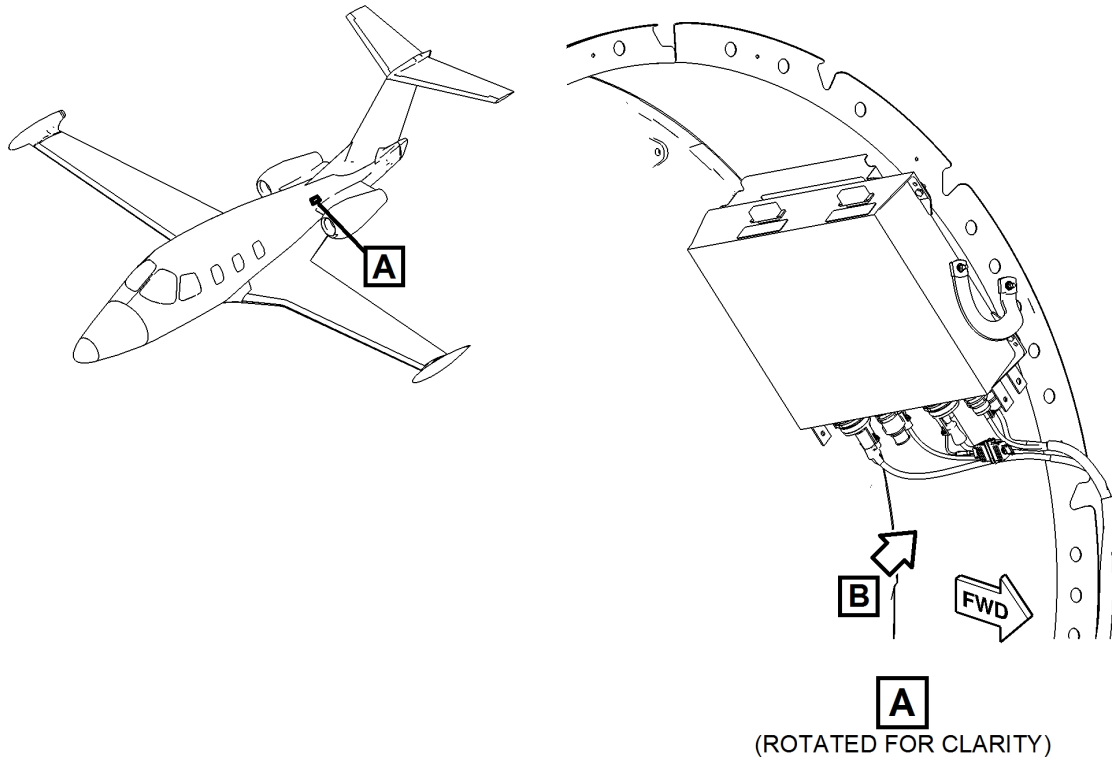

5171941A

Pitot/AOA Probe Auxiliary Heater Fuse Assembly - Removal/Installation
Figure 401 (Sheet 1 of 1)