CHAPTER - 32 HIGHLIGHTS
(Summary of Changes)*Revision No. TR32-10 Apr 19/18*

TO: HOLDERS OF THE AIRCRAFT MAINTENANCE MANUAL (06-117751)

Pages that have been added or revised are summarized below. Remove and insert the affected pages as listed, and enter the above revision number with issue date into the Record of Revisions sheet.

This Temporary Revision incorporates and supersedes previously released temporary revisions for the chapters listed below.

Do not remove this page. Keep it in place as a record of previous changes.

CH/SE/SU Page Block No.	Description of Change
32-10-13 PgBlk 801	Added MLG Shock Absorber seal repack procedure.

THIS PAGE INTENTIONALLY LEFT BLANK

MAIN LANDING GEAR SHOCK ABSORBER ASSEMBLY - REPACK

AMM-32-10-13-031-801

1. General

- A. This task gives the procedures to repack the Main Landing Gear (MLG) shock absorber assembly seals.

There are six seals to be replaced.

(Refer to [Fig. 801.](#))

- Back-up ring [\(5\)](#)
- O-ring [\(6\)](#)
- AGT ring [\(9\)](#)
- AGT ring [\(11\)](#)
- Back-up ring [\(13\)](#)
- O-ring [\(14\)](#)

NOTE: This procedure is for the repacking of the Main Landing Gear Shock Absorber seals and is not to be used as for shock absorber overhaul.

2. Job Set-Up

SUBTASK AMM-32-10-13-031-921-001

- A. Required Test Equipment

- M041-07T005-101/103: Extraction Tool Striker
- M041-07T009-041: Valve Assembly Extraction Tool
- Moog L853-001: Test Rig or equivalent
- Hydraulic hand pump: Commercially available
- 3 way hydraulic fluid distributor: Commercially available

3. Procedure

SUBTASK AMM-32-10-13-031-411-001

(Refer to [Fig. 801.](#))

- A. Remove Shock Absorber from Main Landing Gear. Refer to [AMM-32-10-13-001-801 – Main Landing Gear Shock Absorber Assembly - Removal](#) .

- B. DISASSEMBLY

NOTE: Inspect parts during disassembly for damage. If damaged parts are found other than the seals identified for replacement, replace the shock absorber.

WARNING: MAKE SURE SAFETY PRECAUTIONS ARE OBEYED WHEN WORKING ON NITROGEN SYSTEM OR COMPONENTS. INJURY TO PERSONNEL AND OR DAMAGE TO EQUIPMENT CAN OCCUR. USE PROTECTIVE GOGGLES AND GLOVES.

CAUTION: SHOCK ABSORBER MUST BE UPRIGHT WHEN NITROGEN PRESSURE IS RELEASED, OR ELSE DAMAGE TO EQUIPMENT CAN OCCUR.

- (1) Open the charging valve (15) and let nitrogen and hydraulic fluid mix go out through the valve into a suitable container.
- (2) When the unit is completely depressurized loosen and remove the charging valve (16).
- (3) Drain any remaining hydraulic fluid from the shock absorber.
- (4) Loosen and remove three screws (22) and remove the target WOW (21).
- (5) Remove ring retainer (19).
- (6) Remove four pin dowels (23) using tool M041-07T005-101/103.
- (7) Separate the piston assy (2) and the other installed items from the cylinder assembly (24).
- (8) Remove the slydring (18).
- (9) Remove four pin dowels (3) from piston (2) and remove the piston head (17).
- (10) Remove stop ring (8) and flat valve (7).
- (11) Extract the valve assy (4) using tool M041-07T009-041.
- (12) Remove the back up ring (5) and the O-ring (6) from valve (4).
- (13) Remove the back up ring (13) and the O-ring (14).
- (14) Remove the gland (12) from piston (2).
- (15) Remove the hard landing indicator (20).
- (16) Remove the excluder (9), the slydring (10), and the AGT ring (9) from gland (12).

SUBTASK AMM-32-10-13-031-411-002

(Refer to [Fig. 801.](#))

A. PRE-ASSEMBLY

- (1) The following seals are to be replaced:
 - Back-up ring [\(5\)](#)
 - O-ring [\(6\)](#)
 - AGT ring [\(9\)](#)
 - AGT ring [\(11\)](#)
 - Back-up ring [\(13\)](#)
 - O-ring [\(14\)](#)
- (2) Install the elastic ring [\(1\)](#) on its seat on the top of the piston [\(2\)](#) .
- (3) Slide the hard landing indicator [\(20\)](#) and the retainer ring [\(19\)](#) on the piston.
- (4) Install the AGT ring [\(11\)](#) , the slydring [\(10\)](#) and the excluder DC [\(9\)](#) into the gland [\(12\)](#) .
- (5) Install the O-ring [\(14\)](#) and the back-up ring [\(13\)](#) on the gland [\(12\)](#) .
- (6) Slide the gland [\(12\)](#) on piston [\(2\)](#) .
- (7) Install the O-ring [\(6\)](#) and the back-up ring [\(5\)](#) on the valve [\(4\)](#) .
- (8) Install the flat valve [\(7\)](#) and the stop ring [\(8\)](#) on the bottom of the valve [\(4\)](#) .
- (9) Install the valve group and the piston head [\(17\)](#) on the bottom of the piston [\(2\)](#) . Make sure that all the components holes are aligned.
- (10) Lock all the group to the piston with four pins [\(3\)](#) .
- (11) Install piston bearing [\(18\)](#) .
- (12) Put the piston group into the cylinder [\(24\)](#) and make sure to have the four cylinder holes coincident with the gland holes.
- (13) Install four pins [\(23\)](#) .
- (14) Push the hard landing indicator [\(20\)](#) against the gland [\(12\)](#) .
- (15) Move the ring retainer [\(19\)](#) to have its four holes coincident with the installed pin holes.
- (16) Install the WOW target [\(21\)](#) and lock it with three screws [\(22\)](#) , torque the screws to 12-15 lbf.in (1.36-1.69 Nm).
- (17) Apply PRC-Desoto polysulfide sealant (P/S 890 Class A or C) to the mating surfaces of the three screws [\(22\)](#) , WOW target [\(21\)](#) , ring retainer [\(19\)](#) , hard landing indicator [\(20\)](#) , and top of the piston [\(2\)](#) . Refer to [Fig. 803](#) and [AMM-20-08-00-051-801 – Sealants and Adhesives - Maintenance Practices](#).
- (18) Temporary install the charging valve [\(16\)](#) with its O-ring [\(15\)](#) .

SUBTASK AMM-32-10-13-031-411-003

(Refer to [Fig. 801](#) and [Fig. 803](#).)

A. HYDRAULIC FLUID FILLING - PROOF PRESSURE CHECK OF THE SHOCK ABSORBER

WARNING: BEFORE TO PROCEED, MAKE SURE THAT THERE IS NO PRESSURE IN THE UNIT. DO NOT PRESSURIZE SHOCK ABSORBER TO MORE THAN THE SPECIFIED PRESSURE. IT IS DANGEROUS AND COULD KILL OR CAUSE INJURY.

- (1) Install the shock absorber in the test rig in the vertical position, with the charging valve on the top.
- (2) Remove the charging valve [\(16\)](#).
- (3) Remove the elastic ring [\(1\)](#).
- (4) Connect the hose which supplies fluid to the valve port with a two way fitting.
- (5) Set the test rig to permit the free extension of the shock absorber.
- (6) Set the 3 way distributor to pressure.
- (7) Fill with hydraulic fluid until the shock absorber is fully extended. Do not let the hydraulic fluid pressure exceed 363 psi (25 bar).
- (8) Set the 3 way distributor to return.
- (9) Slowly compress until the shock absorber is in the fully compressed position, and let the excess hydraulic fluid go out.
- (10) Repeat steps 6 to 9 until the hydraulic fluid becomes free of bubbles.
- (11) Check that the total stroke from the fully extended to the fully compressed position of the shock absorber is 4.9611 ± 0.4 in (126 ± 1 mm).
- (12) Keep the shock absorber restrained and fill with hydraulic fluid until the shock absorber is approximately half stroke.
- (13) Apply proof pressure of 4540 psi (313 bar) and keep it for 180 seconds. Check for external leakage.

CAUTION: DO NOT APPLY THE PROOF PRESSURE WITH THE MLG FULLY EXTENDED AGAINST THE PISTON-TO-GLANDS ABUTMENTS.

- (14) Fill with hydraulic fluid until the shock absorber is in the fully extended position.
- (15) Set the 3 way distributor to return and slowly compress the shock absorber until it is in the fully compressed position.
- (16) Drain the excess hydraulic fluid.
- (17) Remove the two way fitting and install the charging valve [\(16\)](#) with a new O-ring [\(15\)](#).
 - (a) Apply lubricant (Dow Corning 55 O-Ring Lubricant) on the new O-ring [\(15\)](#).

-
- (18) Install the elastic ring (1) .
 - (19) Lockwire the following items with MS20995C32 lockwire.
 - (a) Three screws (22) .
 - (b) Charging valve (16) .
 - (20) Apply PRC-Desoto polysulfide sealant (P/S 890 Class A or C) around the charging valve body (16) and shock absorber (2) . Refer to Fig. 803 and [AMM-20-08-00-051-801 – Sealants and Adhesives - Maintenance Practices](#).
 - (21) Install and tighten the charging valve cap by hand.
- B. Install Shock Absorber on to Main Landing Gear. Refer to [AMM-32-10-13-041-801 – Main Landing Gear Shock Absorber Assembly - Installation](#) .
 - C. Do servicing of Main Landing Gear. Refer to [AMM-12-10-06-061-801 – Landing Gear - Servicing](#) .
 - D. After one hour, inspect main landing gear shock absorber for hydraulic fluid leaks. Make sure that Dimension H falls within the tolerances shown in [AMM-12-10-06-061-801 – Landing Gear - Servicing](#) SUBTASK AMM-12-10-06-061-611-002.

4. **Job Close-Up**

SUBTASK AMM-32-10-13-041-921-008

- A. Remove all tools, equipment and unwanted material from work area.

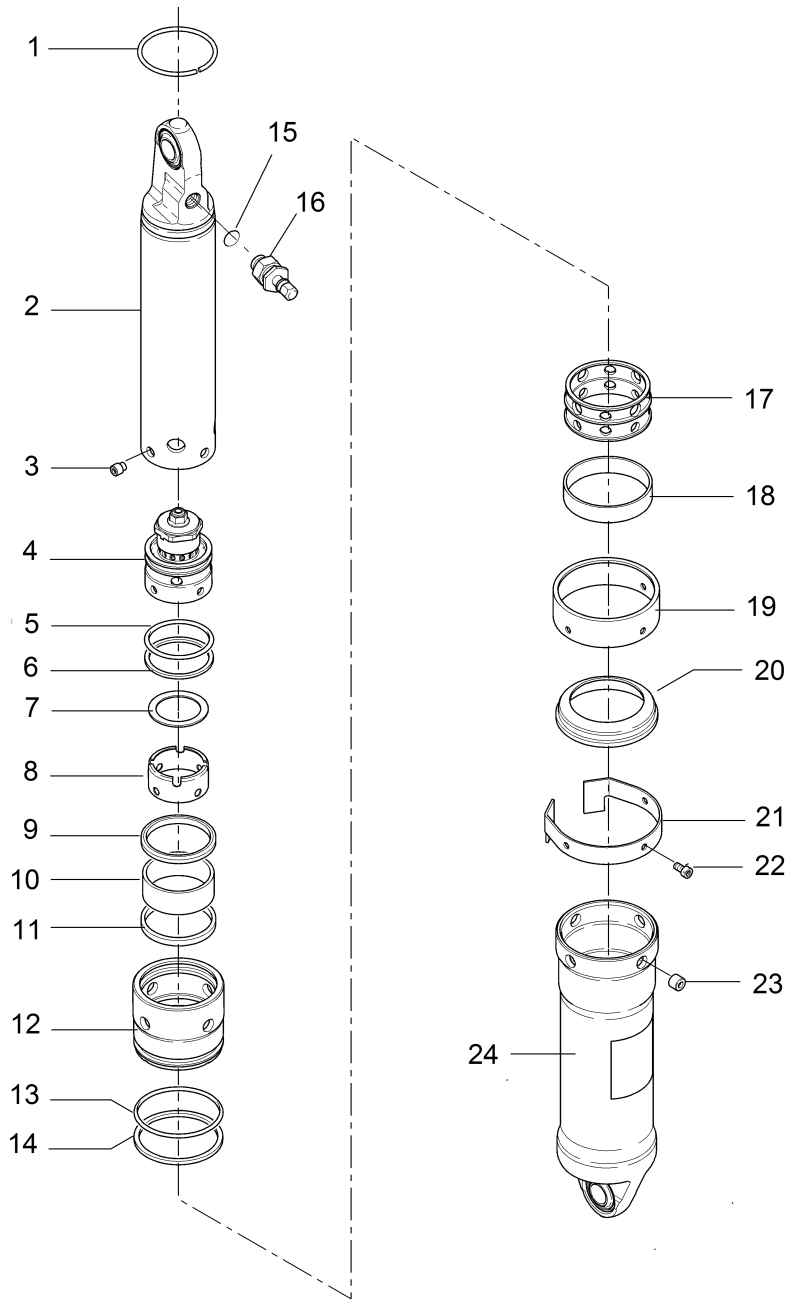

5181972A

Main Landing Gear Shock Absorber Assembly - Repack
Figure 801 (Sheet 1 of 1)

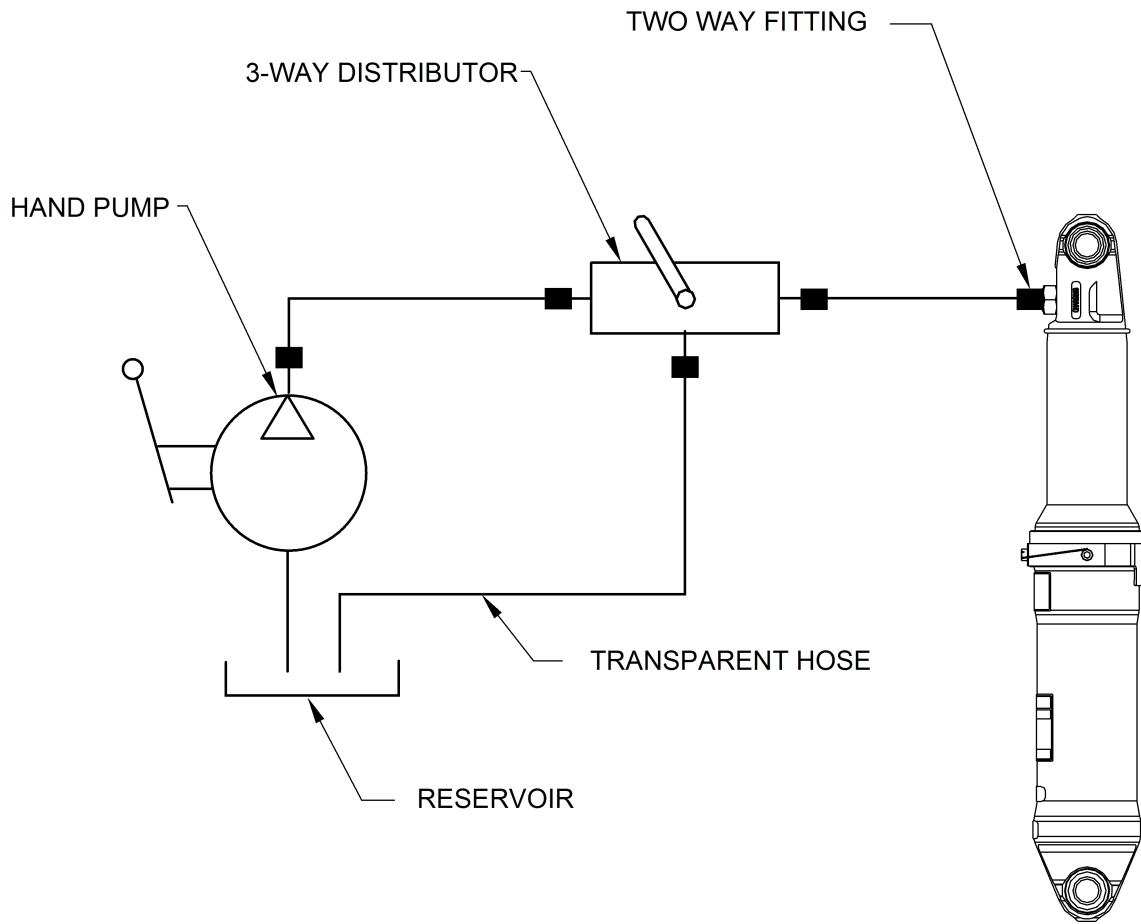

**Hydraulic Fluid Filling Schematic
Figure 802 (Sheet 1 of 1)**

5181973A

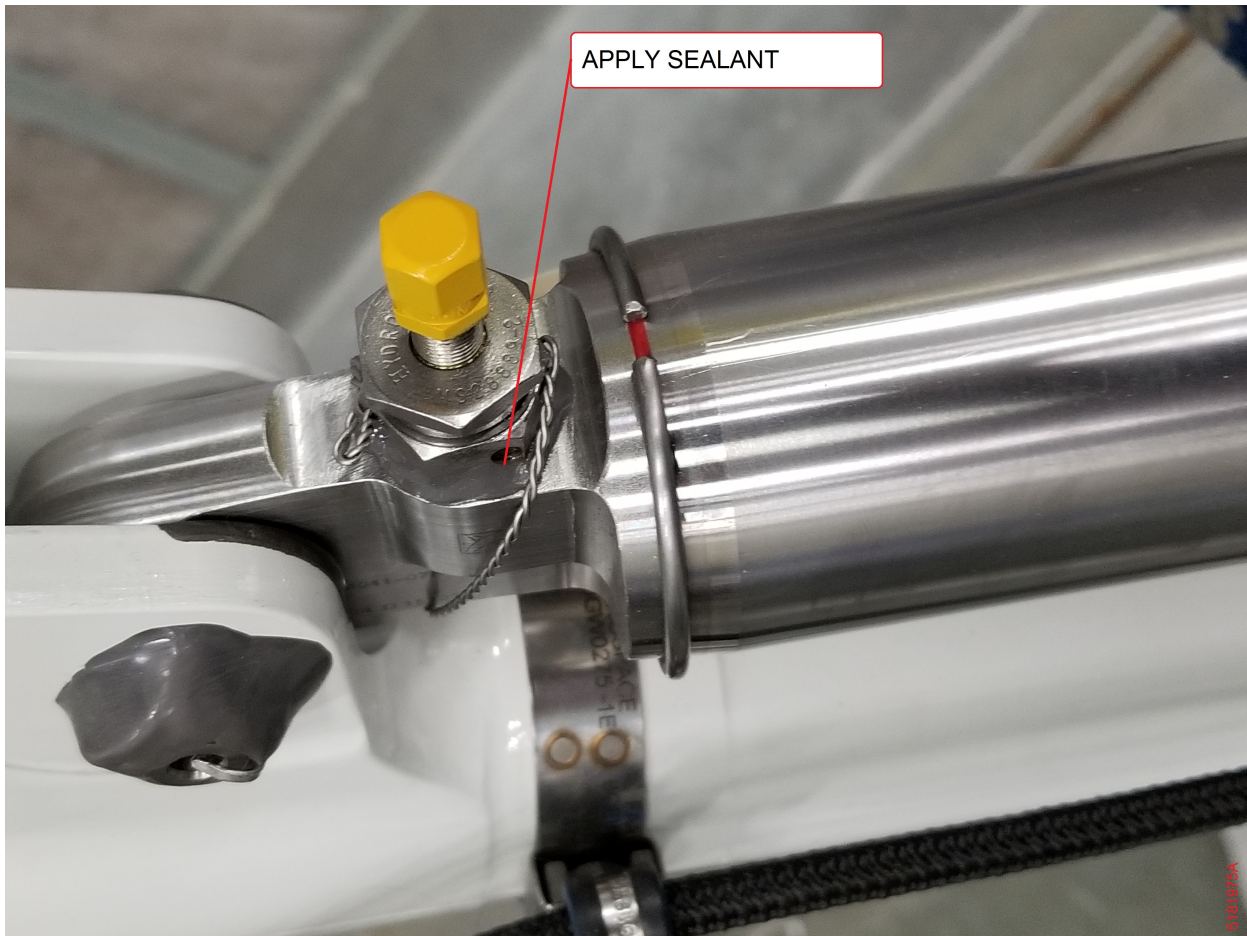

Sealant Application
Figure 803 (Sheet 1 of 2)



Sealant Application
Figure 803 (Sheet 2 of 2)

THIS PAGE INTENTIONALLY LEFT BLANK