

**CHAPTER - 34 HIGHLIGHTS
 (Summary of Changes)**

Revision No. TR34-14 Jan 30/18

TO: HOLDERS OF THE AIRCRAFT MAINTENANCE MANUAL (06-117751)

Pages that have been added or revised are summarized below. Remove and insert the affected pages as listed, and enter the above revision number with issue date into the Record of Revisions sheet.

This Temporary Revision incorporates and supersedes previously released temporary revisions for the chapters listed below.

Do not remove this page. Keep it in place as a record of previous changes.

CH/SE/SU Page Block No.	Description of Change
34-50-20 PgBlk 1 (C)	Revised Description and Operation – Config C.
34-50-20 PgBlk 1 (D)	Added ADS-B Out to Description and Operation. – Config D.
34-50-20 PgBlk 501 (A)	Revised General, Table 1 – Special Tools and Equipment, removed Barfield Altitude testing, Transponder Address Module Programming Procedure (AMC no longer supports this task). Revised Job Close-Up. – Config A.
34-50-20 PgBlk 501 (B)	Removed Barfield Altitude testing, Transponder and Avionics Cooling Fan Fault Checks (Standard System), and referenced Avionics Cooling Fan to AMM-34-50-24. Deleted Enhanced Downlinked Parameters test. – Config B.
34-50-20 PgBlk 501 (C)	Removed Barfield Altitude testing, Transponder and Avionics Cooling Fan Fault Checks (Standard System), and referenced Avionics Cooling Fan to AMM-34-50-24. Deleted Enhanced Downlinked Parameters test. Added ADS-B Test to test matrix. – Config C.
34-50-21 PgBlk 501	Added ADS-B Out check.
34-50-23 PgBlk 401-Inst	Revised Job Close-up test reference.

THIS PAGE INTENTIONALLY LEFT BLANK

TRANSPONDER - DESCRIPTION AND OPERATION

AMM-34-50-20-081-C-801

1. Introduction

- A. Standard Transponder System with or without Extended Squitter: |
- (1) The standard transponder system provides aircraft identification (Mode S), and altitude (Mode C) information to Air Traffic Control.
 - (2) The standard transponder system is made up of the components that follow:
 - Dual standard transponder units installed behind the Primary Flight Displays (PFD)
 - Two transponder antennas
- B. Optional Diversity Transponder System with or without Extended Squitter:: |
- (1) The diversity transponder system provides aircraft identification (Mode S) and altitude reporting information (Mode C) to Air Traffic Control.
 - (2) The diversity transponder system is made up of the components that follow:
 - Dual diversity transponder units installed behind the Primary Flight Displays (PFD)
 - Two transponder antennas
 - Two RF antenna switching relays

2. Description

SUBTASK AMM-34-50-20-081-C-871-001

- A. Standard Transponder System:
- (1) There are two transponders, one (transponder number 1) is installed in the instrument panel behind the left PFD and the other (transponder number 2) is installed in the instrument panel behind the right PFD.
- B. Optional Diversity Transponder System:
- (1) There are two diversity transponders, one (diversity transponder number 1) is installed in the instrument panel behind the left PFD and the other (diversity transponder number 2) is installed in the instrument panel behind the right PFD.
 - (2) There are two RF antenna switching relays, both installed behind the Multi Function Display (MFD). One is inboard of the left diversity transponder and the other is inboard of the right diversity transponder. |

3. **Operation**

SUBTASK AMM-34-50-20-081-C-871-002

A. Standard Transponder System:

The two transponder units located behind the left and right PFDs provide identification information (Modes A and S) and altitude reporting information (Mode C).

The rack mounted dual Mode S transponder system are a radio transmitter-receivers that operate on radar frequencies, receiving ground radar and Traffic Collision Avoidance System interrogations at 1030 MHz and transmitting a coded response of pulses on a frequency of 1090 MHz. The transponder is equipped with the IDENT capability that activates the Special Position Identification pulse for 18 seconds. IDENT function is available through the designated button on the respective side grip.

The GTX 33 replies to Mode A, Mode C, and Mode S interrogations. Mode A replies consist of framing pulses and any one of 4,096 codes (also known as "squawk codes"), which differ in the position and number of pulses transmitted. Mode C replies include framing pulses and encoded altitude.

There are two transponder antennas. The number 1 upper transponder antenna is mounted on the top of the fuselage and is connect to transponder number 1 behind the left PFD. The number 2 lower transponder antenna is mounted on the bottom of the fuselage and is connect to transponder number 2 behind the right PFD.

B. Optional Diversity Transponder System:

As an option, the transponders allow for antenna diversity feature available through the connection of both antennas to a single transponder unit. this is realized by the RF antenna switching relay and the diversity configuration control bit to the PFD available for configuration though the Aircraft Maintenance Computer (AMC). An active transponder alternates between the upper and lower antennas ensures the quality and reliability of the transponder system communications.

TRANSPONDER - DESCRIPTION AND OPERATION

AMM-34-50-20-081-D-801

1. Introduction

A. Standard Transponder System:

- (1) The standard transponder system provides aircraft identification (Mode S), altitude (Mode C), and Automatic Dependent Surveillance Broadcast (ADS-B) OUT information to Air Traffic Control.
- (2) The standard transponder system is made up of the components that follow:
 - Dual standard transponder units with Extended Squitter installed behind the Primary Flight Displays (PFD)
 - Two transponder antennas

B. Optional Diversity Transponder System:

- (1) The diversity transponder system provides aircraft identification (Mode S) and altitude reporting information (Mode C) to Air Traffic Control.
- (2) The diversity transponder system is made up of the components that follow:
 - Dual diversity transponder units installed behind the PFDs.
 - Two transponder antennas
 - Two RF antenna switching relays

C. ADS-B Function

The Extended Squitter enabled transponders provide the capabilities of ADS-B technology, which improves situational awareness and flight safety. The ADS-B OUT function is an option and may be activated through the Multi Function Display (MFD) software key pertinent to a specific aircraft registration number.

2. Description

SUBTASK AMM-34-50-20-081-D-871-001

A. Standard Transponder System:

- (1) There are two transponders, one (transponder number 1) is installed in the instrument panel behind the left PFD and the other (transponder number 2) is installed in the instrument panel behind the right PFD.

B. Optional Diversity Transponder System:

- (1) There are two diversity transponders, one (diversity transponder number 1) is installed in the instrument panel behind the left PFD and the other (diversity transponder number 2) is installed in the instrument panel behind the right PFD.

- (2) There are two RF antenna switching relays, both installed behind the MFD. One is inboard of the left diversity transponder and the other is inboard of the right diversity transponder.

C. ADS-B Function

The Extended Squitter enabled transponders provide the capabilities of ADS-B technology, which improves situational awareness and flight safety. The ADS-B OUT function is an option and may be activated through the MFD software key pertinent to a specific aircraft registration number.

3. **Operation**

SUBTASK AMM-34-50-20-081-D-871-002

A. Standard Transponder System:

The two transponder units located behind the left and right PFDs provide identification information (Modes A and S) and altitude reporting information (Mode C).

The rack mounted dual Mode S transponder system are a radio transmitter-receivers that operate on radar frequencies, receiving ground radar and Traffic Collision Avoidance System interrogations at 1030 MHz and transmitting a coded response of pulses on a frequency of 1090 MHz. The transponder is equipped with the IDENT capability that activates the Special Position Identification pulse for 18 seconds. IDENT function is available through the designated button on the respective side grip.

The GTX 33 replies to Mode A, Mode C, and Mode S interrogations. Mode A replies consist of framing pulses and any one of 4,096 codes (also known as "squawk codes"), which differ in the position and number of pulses transmitted. Mode C replies include framing pulses and encoded altitude.

There are two transponder antennas. The number 1 upper transponder antenna is mounted on the top of the fuselage and is connect to transponder number 1 behind the left PFD. The number 2 lower transponder antenna is mounted on the bottom of the fuselage and is connect to transponder number 2 behind the right PFD.

B. Optional Diversity Transponder System:

As an option, the transponders allow for antenna diversity feature available through the connection of both antennas to a single transponder unit. this is realized by the RF antenna switching relay and the diversity configuration control bit to the PFD available for configuration though the Aircraft Maintenance Computer (AMC). An active transponder alternates between the upper and lower antennas ensure the quality and reliability of the transponder system communications.

C. ADS-B Function

The Extended Squitter enabled transponders provides the capabilities of ADS-B technology, which improves situational awareness and flight safety. With ADS-B capabilities, position, velocity, and heading information are automatically transmitted to other aircraft and ground stations. The current Air Traffic Control system depends on a transponder request for pertinent aircraft information. ADS-B provides immediate surveillance of air-to-air traffic and aircraft in remote or inhospitable areas not currently covered by radar.

TRANSPONDER - ADJUSTMENT/TEST

AMM-34-50-20-071-A-801

1. General

- A. This task gives procedures to do the adjustment/test of the transponder components.
- An adjustment/test is only required for the transponder that is being installed. The opposite transponder, if it has not been removed, does not require an adjustment/test

2. Equipment and Materials

Table 501. Special Tools and Equipment

Name and Part Number
Transponder Test Set (Aeroflex, IFR6000)
Weight-on-Wheels (WOW) Box (EAI, 87-117390-1001) or Avio Maintenance Computer (AMC) (EAI 20-120576-1001 or 20-121926-1001), SW version "1.5.71 or higher" for Pre-Avio NG aircraft and "2.2.02 or higher" for Avio NG aircraft
PCMCIA to Parallel Port Adapter, (Quatech, PN SPP-100), for use with Transponder Programming Kit, (Bender, PN AMP6400-1 (parallel port) or PN AMP6400-2 (USB)).
Transponder Programming Kit, (Bender, PN AMP6400-1 (parallel port) or PN AMP6400-2 (USB))
Personal Computer (PC) — for Address Module Programming

3. Job Set-Up

SUBTASK AMM-34-50-20-071-A-921-001

- A. Make aircraft safe for maintenance. Refer to [AMM-20-00-01-051-801 – Make Safe For Maintenance](#).
- B. If on jacks, refer to [AMM-07-10-00-051-801 – Jacking - Maintenance Practices](#) and [AMM-08-20-00-051-801 – Leveling](#).
- C. Connect external power. Refer to [AMM-24-40-00-051-801 – External Power - Maintenance Practices](#). Do turn on START BATT and SYS BATT switches until prompted.
- D. Prepare Anti-ice system for maintenance. Refer to [AMM-20-00-03-051-801 – Prepare Anti-Ice Systems For Maintenance](#).
- E. Take proper safety precautions to protect personnel. Position aircraft such that multi-path RF reflections between the IFR-6000 test set, the aircraft's antennas, and surrounding

objects are minimized. The area on the left side of the aircraft should not be up against a metal wall or another aircraft. If necessary, position the aircraft outside, away from metal buildings or other aircraft. Refer to [Fig. 501](#).

CAUTION: FAILURE TO COMPLY WITH THIS STEP AND CONTINUING WITH THIS PROCEDURE COULD IMPACT LOCAL AIRPORT TOWER OPERATIONS.

- F. If applicable, contact local airport tower to inform them a transponder test is being run at your location (inside or outside). Request appropriate squawk and allotted time to run test.

NOTE: If local airport tower is not informed, use code 1200.

- G. Attach test set antenna to Transponder Test Set using 1 foot long test set cable (blue cable, supplied if IFR6000 is used), connected to ANT port on tester.
- H. During testing, place the Transponder Test Set antenna approximately two feet to four feet forward and in line with right wing tip tank. May require periodic repositioning between two and four feet.
- I. Connect WOW Box or AMC to aircraft. Refer to AMM-20-00-04-051-801 – Weight On Wheels (WOW) Box - Connect/Disconnect. Make sure switches are set to W-on-W.

4. **Procedure**

SUBTASK AMM-34-50-20-071-A-701-001

- A. Do adjustment/test of the Transponder System as follows:

- (1) Perform job setup, refer to [SUBTASK AMM-34-50-20-071-A-921-001](#).
- (2) Push ECB BY SYSTEM soft key. Scroll to FLT CTRLS using outer knob. Push inner knob to select. Scroll to the listed ECB using outer knob and highlight. Push “COLLAR” Soft key. Press “CONFIRM COLLAR” soft key.
 - ECB - NOSE LDG GEAR (L AFT Bus)
 - ECB - L MAIN LDG GEAR (L AFT Bus)
 - ECB - R MAIN LDG GEAR (L AFT Bus)
- (3) Set WOW Box to W-off-W.

NOTE: Transponders only turn on with Weight-off-Wheels.

- (4) Set both left and right PFD baro set to 29.92 on Autopilot Control Panel (ACP) by pressing BARO SET knob.

- B. Transponder-1 Setup using Transponder Test Set, IFR6000

- (1) Press the bottom right rocker switch on the left PFD to select XPDR.

NOTE: The XPDR select page times out and switches back to the COM page after 30 seconds. Select XPDR page from time to time during this test.

- (2) Press ACTIVE softkey (upper right button) on the left PFD to select XPDR1.

- (3) CODE status box on the left PFD and right PFD shows 1200.
 - (a) To change CODE, scroll to XPDR using softkey. Use outer knob to highlight and inner knob to change numeric values.
- (4) Press MODE softkey on the left PFD to select ON.
- (5) Press the bottom right rocker switch on the right PFD to select XPDR.

NOTE: The XPDR select page times out and switches back to the COM page after 30 seconds. Select XPDR page from time to time during this test.
- (6) Press ACTIVE softkey (upper right button) on the right PFD to select XPDR1.
- (7) Set CODE to 1300, scroll to XPDR using softkey, and use the outer knob to highlight and inner knob to change numeric values.
- (8) CODE status box on the Left PFD and Right PFD shows 1300.

NOTE: Upon completion of Right PFD test, return CODE to 1200.
- (9) Press MODE softkey on the right PFD to select ON.
- (10) Using the pilot's keyboard, perform the following steps:
 - (a) Press XPDR1.
 - Keyboard XPDR1 LED is lit.
 - (b) Press ON.
 - (c) Press XPDR SQWK.
 - (d) Using the keyboard numbers, set the code to 1200.
 - (e) Press Enter.
 - CODE status box on the left PFD shows 1200.

C. Transponder-1 MODE A,C,S Test using Transponder Test Set, IFR6000

- (1) Power up the Transponder Test Set, IFR6000 and press SET UP button on the test set. Press XPDR to display AUTO TEST until XPDR-AUTO TEST is displayed. Using UP/DOWN buttons scroll to GENERIC MODE S press SET UP button on IFR 6000 to go to SET UP-XPDR display
 - Display shows: SETUP XPDR.
- (2) Use either PREV PARAM or NEXT PARAM button to highlight RF Port selection window. Using Up/Down arrow keys, select Antenna.
 - (a) Press NEXT PARAM to scroll to the TOP ANT RANGE and ANT HEIGHT.

NOTE: If the BOTTOM antenna is boxed, press XPDR button, then press Select Antenna. Use SELECT ANT button to toggle to TOP. Press SETUP button to return to previous screen.
 - (b) Enter estimated distance that the test set antenna is from the aircraft using up/down buttons.

- (c) Press NEXT PARAM and enter estimated height of aircraft antenna from ground.
 - (d) Select NEXT PARAM until ANT CABLE LOSS is highlighted. Obtain cable loss value from cable running between antenna and Test set (denoted by Value followed by dB). Enter the data on Transponder Test Set, IFR6000.
 - (e) Press NEXT PARAM and enter the dBi value directly beneath the GHz values 1.03 and 1.09 from antenna data plate. Enter the data on Transponder Test Set, IFR6000.
- (3) Press XPDR button to go to the XPDR AUTO TEST page.
 - (4) Press CONFIG button. On the CONFIG line, scroll to GENERIC MODE S using the up/down buttons. Press Return button and select Run Test, found on display screen.
 - Top ERP dBm should be between 48 to 60 and MTL. dBm should be between -67 to -79 to PASS.
 - (5) If values are obtained and test FAILS, press TEST LIST button on IFR 6000 and, using up/down buttons, scroll to the specific failed test. Press SELECT TEST button, adjust IFR antenna, and press RUN TEST button until PASS message appears.

NOTE: This may take several adjustments until IFR 6000 and aircraft transponder SYNC UP.
 - (6) Press STOP TEST button.
 - (7) Repeat until all FAILED tests have been completed.
 - (8) Press Return button on IFR 6000 to return to XPDR-AUTO. TEST screen appears.
 - A PASS message should be displayed.

NOTE: If POWER/FREQ test fails, after pressing RUN TEST, adjust antenna until PASS message appears. Stop adjusting antenna as soon as PASS message appears and press STOP TEST button. This test performs a live update of the dBm values needed to achieve a PASS message for test.
 - (9) On left PFD, scroll to XPDR using lower softkey.
 - (10) Press MODE softkey to change the mode to ALT.
 - (11) CODE status box on the left PFD and right PFD show 1200.
 - (12) Press RUN TEST button on Transponder Test Set, IFR6000.

Transponder Test Set, IFR6000 indicates:

 - A Code = 1200
 - C Alt = Reading within +/- 100 ft. of the Left PFD altitude reading
 - (13) On Transponder Test Set, IFR6000, press XPDR button one time. Check that the following is displayed:
 - XPDR – ALT ENCODER
 - (14) On Transponder Test Set, IFR6000, press Source Select button. Check that the following is displayed:

- SOURCE: XPDR
- (15) On Transponder Test Set, IFR6000, select RUN TEST.
NOTE: Wait approximately 30 Seconds between cockpit IDENT tests.
 - (16) Press IDNT key on the Pilot's keyboard.
 - IDENT is displayed on Transponder Test Set, IFR6000.NOTE: IDENT disappears from the IFR test set in approximately 20 seconds.
 - (17) Press IDNT key on the Copilot's keyboard (If Installed).
 - IDENT is displayed on Transponder Test Set, IFR6000.NOTE: IDENT disappears from the IFR test set in approximately 20 seconds.
 - (18) Press IDNT button on the Pilot's Stick Grip.
 - IDENT is displayed on Transponder Test Set, IFR6000.NOTE: IDENT disappears from the IFR test set in approximately 20 seconds.
 - (19) Press IDENT button on the Copilot's Stick Grip.
 - IDENT is displayed on Transponder Test Set, IFR6000.NOTE: IDENT disappears from the IFR test set in approximately 20 seconds.
 - (20) Press STOP TEST button on Transponder Test Set, IFR6000.
- D. Transponder-2 MODE A,C,S Test using Transponder Test Set, IFR6000
- (1) Realign the Transponder Test Set, IFR6000 flat plane antenna to point at the aircraft Transponder 2 Antenna located in the Center Belly.
 - (2) Power up the Transponder Test Set, IFR6000 (if required), and press SET UP button one time on the test set, and press XPDR to display AUTO TEST until XPDR-AUTO TEST. Using up/down buttons, scroll to GENERIC MODE S press SET UP button on IFR 6000 to go to SET UP-XPDR display
 - Display shows SETUP XPDR.
 - (3) Use either PREV PARAM or NEXT PARAM button to highlight RF Port: selection window. Using up/down arrow keys, select ANTENNA.
 - (a) Press NEXT PARAM to scroll to the TOP ANT RANGE and ANT HEIGHT.
NOTE: If BOTTOM antenna is boxed, press XPDR button, then press Select Antenna. Use the SELECT ANT button to toggle to TOP. Press Set-up button to return to previous screen.
 - (b) Enter estimated distance that the test set antenna is from the aircraft using up/down buttons.
 - (c) Press NEXT PARAM and enter estimated height of aircraft antenna from ground.

- (d) Select NEXT PARAM until ANT CABLE LOSS is highlighted. Obtain cable loss value from cable running between antenna and Test set (denoted by value followed by dB). Enter the data on Transponder Test Set, IFR6000.
 - (e) Press NEXT PARAM and Enter the dBi value directly beneath the GHz values 1.03 and 1.09 from antenna data plate. Enter the data on Transponder Test Set, IFR6000:
- (4) On left PFD use lower right softkey to scroll to XPDR, press ACTIVE softkey (upper right button) on the left PFD to select XPDR2.
 - (5) Press MODE softkey button on the Left PFD to select ON
 - (6) Press XPDR button to go to the XPDR AUTO TEST page.
 - (7) Press CONFIG button. On the CONFIG line, scroll to GENERIC MODE S using the up/down buttons and press the Return button and select RUN TEST, found on display screen.
 - Bottom ERP dBm should be between 48 to 60 and MTL dBm should be between -67 to -79 to PASS.
 - (8) If values are obtained and test FAILS, press TEST LIST button on IFR 6000 and using the up/down buttons, scroll to the specific failed test. Press SELECT TEST button, adjust IFR antenna and press RUN TEST button until PASS message appears

NOTE: This may take several adjustments until IFR 6000 and aircraft Transponder SYNC UP.
 - (9) Press STOP TEST button.
 - (10) Repeat until all FAILED tests have been completed.
 - (11) Press Return button on IFR 6000 to return to XPDR-AUTO TEST screen appears.
 - A PASS message should appear.

NOTE: If POWER/FREQ test fails, after pressing RUN TEST, adjust Antenna until PASS message appears. Stop adjusting antenna as soon as PASS message appears and press STOP TEST button. This test performs a LIVE update of the dBm values needed to achieve a PASS message for test.
 - (12) On left PFD press MODE softkey to change the mode to ALT.
 - (13) CODE status box on the Left PFD and Right PFD show 1200.
 - (14) Press RUN TEST button on Transponder Test Set, IFR6000.
Transponder Test Set, IFR6000 indicates:
 - “A Code” = 1200
 - “C Alt” = Reading within +/- 100 ft. of the right PFD altitude reading
 - (15) On Transponder Test Set, IFR6000, press XPDR button one time. Check that the following is displayed:
 - XPDR – ALT ENCODER

-
- (16) On Transponder Test Set, IFR6000, press SOURCE SELECT button. Check that the following is displayed:
 - SOURCE: XPDR
 - (17) On Transponder Test Set, IFR6000, select RUN TEST.
NOTE: Wait approximately 30 seconds between cockpit IDENT Tests
 - (18) Press IDNT key on the pilot's keyboard.
 - IDENT is displayed on Transponder Test Set, IFR6000.NOTE: IDENT will disappear from the IFR test set in approximately 20 seconds.
 - (19) Press IDNT key on the Copilot's keyboard. (If Installed)
 - IDENT is displayed on Transponder Test Set, IFR6000.NOTE: IDENT will disappear from the IFR test set in approximately 20 seconds.
 - (20) Press IDNT button on the Pilot's Stick Grip.
 - IDENT is displayed on Transponder Test Set, IFR6000.NOTE: IDENT will disappear from the IFR test set in approximately 20 seconds.
 - (21) Press IDNT button on the Copilot's Stick Grip.
 - IDENT is displayed on Transponder Test Set, IFR6000.NOTE: IDENT will disappear from the IFR test set in approximately 20 seconds.
 - (22) Press STOP TEST button on Transponder Test Set, IFR6000.
- E. Generic Mode S Test
- (1) Press STOP TEST button on Transponder Test Set, IFR6000.
 - (2) Make sure XPDR is still in MODE ALT on Left PFD.
 - (3) On Transponder Test Set, IFR6000, select XPDR button. On CONFIG line, scroll using up/down buttons to GENERIC MODE S. Press Return button.
 - (4) On Transponder Test Set, IFR6000, select Run Test. Expected results are as follows:
 - PASS, displayed on Transponder Test Set, IFR6000
 - the tail number listed on the test set matches the aircraft tail numberNOTE: If the tail number is not displayed, refer to [SUBTASK AMM-34-50-20-071-A-701-002](#).
 - (5) Scroll to XPDR on Left PFD, Press the MODE softkey button to change the mode to STBY.
 - (6) On Transponder Test Set, IFR6000, select Run Test.
 - Check that the NO REPLY message appears on upper section of Transponder Test Set, IFR6000.

5. Transponder Address Module Programming Procedure

SUBTASK AMM-34-50-20-071-A-701-002

- A. The 24-bit ICAO address is stored for the transponder in the Address Module PN: AM6400-1-(01).

Program the Transponder Address Module as follows:

- (1) Remove Transponder Address Module from back of PFD.
- (2) Use address module programmer kits AMP6400-1 (parallel interface) or AMP6400-2 (USB interface), along with a PC to program the Address Module.

NOTE: The CD-ROM, which is part of the address module programmer kit, includes the programming procedure. Insert the CD-ROM into a PC and follow the instructions. If autostart is disabled on your PC, you have to start "setup.exe" manually.

- (3) Reinstall Transponder Address Module on back of PFD.

6. Job Close-Up

SUBTASK AMM-34-50-20-071-A-921-002

- A. Set WOW Box switches to W-on-W
- B. Reset the collared ECB's. Refer to AMM-20-00-03-051-801 – Prepare Anti-Ice Systems For Maintenance.
- C. Power down the aircraft by setting the SYS BATT and START BATT switches to OFF and the BUS TIE to OPEN.
- D. Disconnect WOW Box from aircraft. Refer to AMM-20-00-04-051-801 – Weight On Wheels (WOW) Box - Connect/Disconnect.
- E. Remove all tools, equipment and unwanted material from work area.
- F. Disconnect external power. Refer to [AMM-24-40-00-051-801 – External Power - Maintenance Practices](#).
- G. If all other maintenance is complete, return aircraft to service. Refer to [AMM-20-00-02-051-801 – Return To Service \(After Maintenance\)](#).

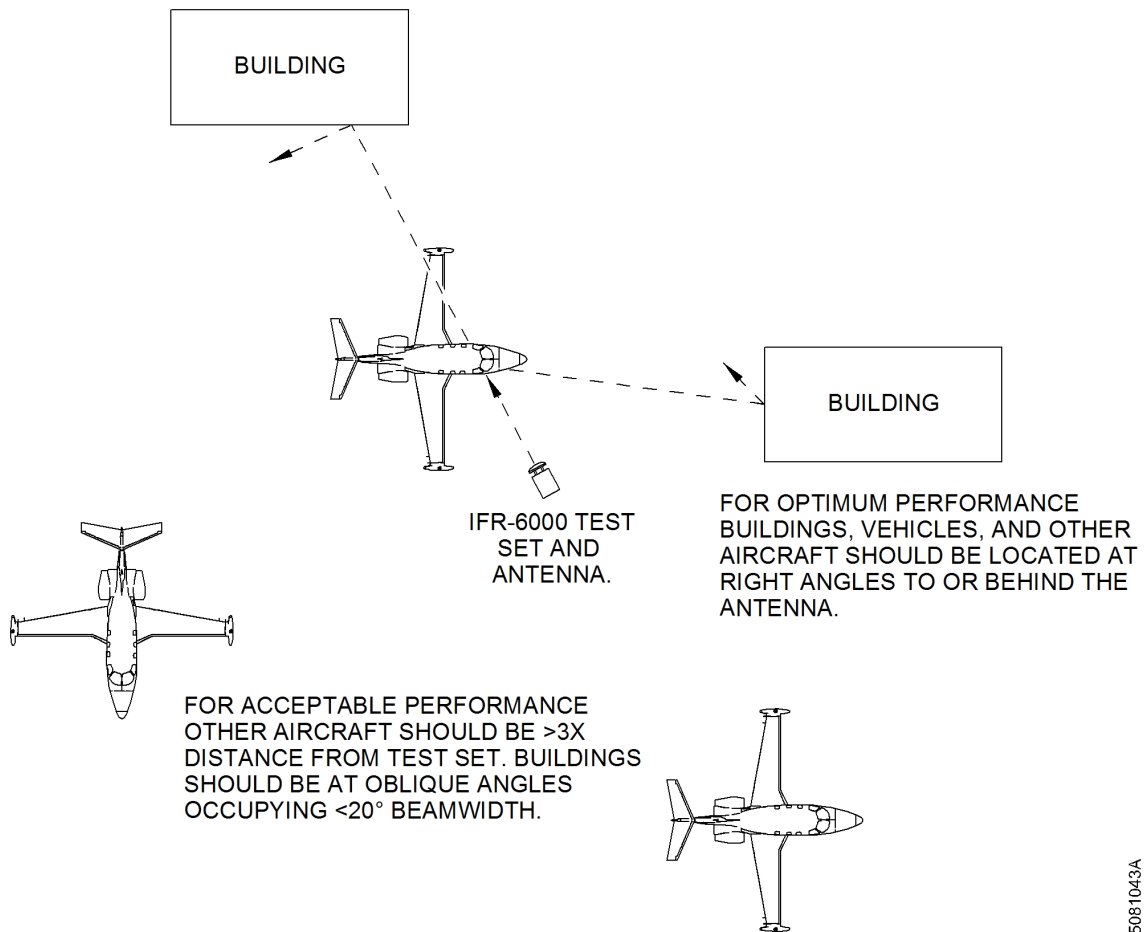
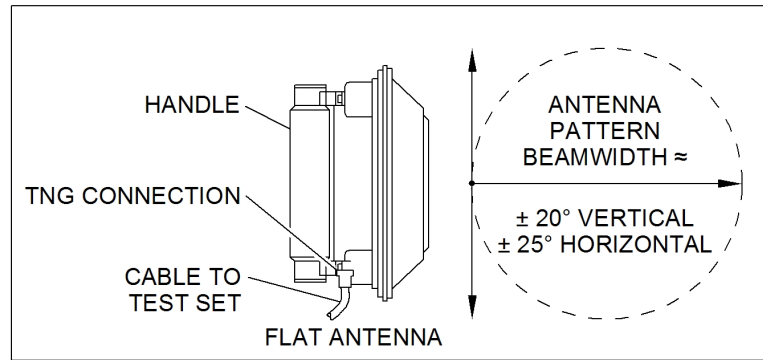

5081043A

**Transponder - Adjustment/Test
Figure 501 (Sheet 1 of 1)**

THIS PAGE INTENTIONALLY LEFT BLANK

TRANSPONDER - ADJUSTMENT/TEST

AMM-34-50-20-071-B-801

1. General

- A. This task gives procedures to do the adjustment/test of the:
- Dual Standard (Non-Diversity) Transponder System and components (or) Optional Dual Diversity Transponder System and components.
 - An adjustment/test is only required for the transponder that is being installed. The opposite transponder, if it has not been removed, does not require an adjustment/test
- (1) Refer to [Table 501](#) for testing procedures.

Table 501. Test Matrix

System Test	Procedures
Dual Standard Transponder System Test	Std. Transponder 1 Adjustment/Test: SUBTASK AMM-34-50-20-071-B-701-001 , and Std. Transponder 2 Adjustment/Test: SUBTASK AMM-34-50-20-071-B-701-002 . Transponder Cooling Adjustment/Test: TASK AMM-34-50-24-071-801 .
Dual Diversity Transponder System Test	Diversity Transponder 1 Adjustment/Test: SUBTASK AMM-34-50-20-071-B-701-003 , and Diversity Transponder 2 Adjustment/Test: SUBTASK AMM-34-50-20-071-B-701-004 . Transponder Cooling Adjustment/Test: TASK AMM-34-50-24-071-801 .

2. Equipment and Materials

- A. Special Tools and Equipment

Name and Part Number
Transponder Test Set (Aeroflex, IFR6000) or equivalent
Weight-on-Wheels (WOW) Box (EAI, 87-117390-1001) or AMC 2.4.01 (or higher).
Ground Power Unit (GPU). AllStar 450 or AllStar G.S.E. or Hobart GPU-400 or Hobart GPU-600 or Bycan PS-28100

3. **Job Set-Up**

SUBTASK AMM-34-50-20-071-B-921-001

- A. Make aircraft safe for maintenance. Refer to [AMM-20-00-01-051-801 – Make Safe For Maintenance](#).
- B. If on jacks, refer to [AMM-07-10-00-051-801 – Jacking - Maintenance Practices](#) and [AMM-08-20-00-051-801 – Leveling](#).
- C. Connect external power. Refer to [AMM-24-40-00-051-801 – External Power - Maintenance Practices](#). Do not turn on START BATT and SYS BATT switches until prompted.
- D. Prepare Anti-ice system for maintenance. Refer to [AMM-20-00-03-051-801 – Prepare Anti-Ice Systems For Maintenance](#).
- E. Take proper safety precautions to protect personnel. Position aircraft such that multi-path RF reflections between the IFR-6000 test set, the aircraft's antennas, and surrounding objects are minimized. The area on the left side of the aircraft should not be up against a metal wall or another aircraft. If necessary, position the aircraft outside, away from metal buildings or other aircraft. Refer to [Fig. 501](#).

CAUTION: FAILURE TO COMPLY WITH THIS STEP AND CONTINUING WITH THIS PROCEDURE COULD IMPACT LOCAL AIRPORT TOWER OPERATIONS.

- F. If applicable, contact local airport tower to inform them a transponder test is being run at your location (inside or outside). Request appropriate squawk and allotted time to run test.

NOTE: If local airport tower is not informed, use code 1200.

- G. Attach test set antenna to Transponder Test Set using 1 foot long test set cable (blue cable, supplied if IFR6000 is used), connected to ANT port on tester.
- H. During testing, place the Transponder Test Set antenna approximately two feet to four feet forward and in line with right wing tip tank. May require periodic repositioning between two and four feet.
- I. Connect Weight On Wheels (WOW) box or Aircraft Maintenance Computer (AMC) and set switches on Box to W-On-W. Refer to [AMM-20-00-04-051-801 – Weight On Wheels \(WOW\) Box - Connect/Disconnect](#).

4. **Transponder–1 Adjustment/Test (Standard System)**

SUBTASK AMM-34-50-20-071-B-701-001

- A. Begin adjustment/test as follows:
 - (1) Perform job setup, refer to [SUBTASK AMM-34-50-20-071-B-921-001](#).
 - (2) Re-align the Transponder Test Set, IFR6000 antenna to point at the aircraft's Transponder–1 antenna (top of the center cabin/fuselage).

- (3) Use the small rotary knob on the left PFD to select XPDR page.
NOTE: The XPDR select page will time out and switch back to the COM page after 30 seconds. The operator will have to select XPDR page from time to time during this test. Make sure that Transponder 1 (XPDR 1) is selected as ACTIVE transponder in STANDBY MODE.
 - (4) Scroll to FLT CTRLS using outer knob. Push inner knob to select. Scroll to the listed ECB using outer knob and highlight. Push “COLLAR” soft key. Push “CONFIRM COLLAR” soft key.
 - ECB - NOSE LDG GEAR (L AFT Bus)
 - ECB - L MAIN LDG GEAR (L AFT Bus)
 - ECB - R MAIN LDG GEAR (L AFT Bus)
 - (5) Scroll to ENGINE using outer knob. Push inner knob to select. Scroll to the listed ECB using outer knob and highlight. Push “COLLAR” soft key. Push “CONFIRM COLLAR” soft key.
 - ECB - L ENG FIRE EXTNGR (L FWD Bus)
 - ECB - R ENG FIRE EXTNGR (R FWD Bus)
 - (6) Clear any “MASTER CAUTIONS” and “MASTER WARNINGS” as needed.
 - (7) Set both left and right PFD baro set to 29.92 (in/Hg) on Autopilot Control Panel (ACP) by pushing BARO SET knob.
- B. Transponder-1 Setup
- (1) Use the small rotary knob on the left PFD to select XPDR page.
NOTE: The XPDR select page times out and switches back to the COM page after 30 seconds. Select XPDR page from time to time during this test.
 - (2) Make sure that Transponder 1 (XPDR 1) is selected as ACTIVE transponder in STANDBY MODE.
 - (3) Push CODE soft key on left PFD and enter the transponder code provided by the control tower for this test. If no code was assigned, enter 1200.
- C. Transponder-1 MODE A,C,S Test using Transponder Test Set, IFR6000
- (1) Power up the Transponder Test Set (IFR 6000). After tester performs Self Test, push SETUP button on the test set to bring up the SETUP-XPDR page. If necessary, continue pressing SETUP button until tester cycles to SETUP-XPDR page.
 - (2) On the Transponder Test Set (IFR 6000)'s SETUP-XPDR page, use NEXT PARAM or PREV PARAM soft keys to select each parameter, and the “arrow” DATA keys to set the values listed below.
 - ANTENNA: TOP
 - RF PORT: ANTENNA
 - ANT RANGE-TOP: 18 ft.

- ANT HEIGHT-TOP: 7 ft.
- ANT RANGE-BOTTOM: 18 ft.
- ANT HEIGHT-BOTTOM: 1 ft.
- DIR CABLE LOSS: Ignore
- ANT CABLE: 1 ft.
- ANT CABLE LOSS: As marked on blue cable (should be 0.1 dB)
- ANT GAIN (dBi) - 1.03 GHz: As marked on test set antenna
- ANT GAIN (dBi) - 1.09 GHz: As marked on test set antenna
- UUT ADDRESS: AUTO
- MANUAL AA: Ignore
- DIVERSITY TEST: OFF
- PWR LIM: FAR 43
- CHECK CAP: YES

(3) Push XPDR button to go to the XPDR-AUTO TEST page.

(4) Push CONFIG soft key to display the XPDR-CONFIG SCREEN page.

(5) On the XPDR-CONFIG SCREEN, scroll to GENERIC MODE S using the UP/Down DATA keys.

(6) With GENERIC MODE S highlighted, push RETURN soft key to confirm selection. This will also cause a return to the XPDR-AUTO TEST page.

(7) Set the WOW test box or AMC to W-off-W.

NOTE: Transponder will transition to ALT mode automatically when airborne or simulated airborne (W-off-W).

(8) Push RUN TEST soft key to start AUTO TEST. The tester will sequence through separate tests, after which a "PASS" message should be displayed.

- (9) Top ERP should be between 48 to 60 dBm and MTL should be between -68 to -80 dBm to PASS.

NOTE: If values are obtained and any of the individual tests FAIL during AUTO TEST, press TEST LIST button on IFR 6000 and using UP/DOWN buttons scroll to the specific Failed test(s). Press SELECT TEST button, adjust IFR 6000 test set positioning anywhere within a 30 foot arc between the aircraft's right wingtip and the nose as required, and Press RUN TEST button until PASS Message is received (this may take several test set position adjustments until IFR 6000 and aircraft Transponder "Sync up"). Press STOP TEST button. Repeat until all individual FAILED tests have achieved a PASS. It is not necessary to re-run AUTO TEST. AUTO TEST is a convenience feature only.

NOTE: If POWER/FREQ test Fails: After pressing RUN TEST, adjust IFR-6000 test set positioning while test is running until PASS message appears (this test performs a "Live" update of the dBm values). It may be required to position the test set anywhere within a 30 foot arc between the aircraft's right wingtip and the nose. Press the STOP TEST button as soon as PASS message is displayed

- (10) Push RUN TEST soft key on Transponder Test Set (IFR 6000) again.
- (11) Make sure the following appears on the Transponder Test Set (IFR 6000):
- "A CODE" = transponder code entered
 - "C ALT" = left PFD altitude indication +/- 100 ft.
 - "S CODE" = ICAO code assigned to this aircraft/tail number
 - "TAIL" = tail number assigned to this aircraft
 - DF17 DETECTED = YES (IF ADS-B OUT IS INSTALLED) / NO (IF ADS-B OUT IS NOT INSTALLED)
 - "FLT ID" = same as tail number
 - "AA" = ICAO code assigned to this aircraft/tail number (8 digit number in parenthesis)
 - "FS" = IN-AIR
 - "VS" = IN-AIR
- (12) On MFD, press SYS along bottom of MFD. Use the small lower knob on the MFD to scroll to the SETUP page. On the SETUP page, press the SETTINGS softkey to bring up the SETTINGS page. At the bottom of the SETTINGS page, check:
- (a) The "REGISTRATION NO" number (alphanumeric) matches the "TAIL" number (alphanumeric) displayed on the IFR 6000 (above).

- (13) The “ICAO 24-BIT (OCT)” number matches the “AA” ICAO 24-bit code displayed on the IFR 6000 (above).

NOTE: If the aircraft’s registration number and/or ICAO 24-bit (octal) number are not present on the MFD’s SETTINGS page, the Aircraft Configuration File must be updated, refer to [AMM-31-40-00-051-801 – Aircraft Computer Systems - Maintenance Practices](#). Steps (15) through this step must then be repeated.

- (14) On the MFD, scroll to the SETUP tab, press the SENSOR Soft Key.
- (15) Set the ADC PFD source selection from AUTO to ADC 2.
- (16) On the IFR 6000, press the XPDR button once. Once XPDR – ALT ENCODER is displayed, press the SOURCE SELECT Soft Key until SOURCE - XPDR is displayed. Press the RUN TEST Soft Key.
- (17) Make sure that an altitude reported on IFR 6000 matches L PFD altitude indication +/- 100 ft.
- (18) On the MFD, set the ADC source back to AUTO.
- (19) Set the WOW Box Switches to W-on-W (on-ground).
- (20) Set XPDR 1 to STANDBY MODE.

5. Transponder–2 Adjustment/Test (Standard System)

SUBTASK AMM-34-50-20-071-B-701-002

A. Begin adjustment/test as follows:

- (1) Perform job setup, refer to [SUBTASK AMM-34-50-20-071-B-921-001](#).
- (2) Re-align the Transponder Test Set, IFR6000 antenna to point at the aircraft’s lower Transponder–2 antenna (bottom of the center cabin/fuselage).
- (3) Place WOW box switches to W-on-W (on ground).
- (4) Use the small rotary knob on the left PFD to select XPDR page.

NOTE: The XPDR select page will time out and switch back to the COM page after 30 seconds. The operator will have to select XPDR page from time to time during this test.

- (5) Push ACTIVE soft key, upper right button, on the left PFD to select XPDR 2.
 - (a) Make sure that Transponder 2 (XPDR 2) is in STANDBY MODE.

B. Transponder-2 Setup

- (1) Push CODE soft key on right PFD and enter the transponder code provided by the control tower for this test. If no code was assigned, enter 1200.

C. Transponder-2 MODE A,C,S Test using Transponder Test Set, IFR6000

- (1) Power up the Transponder Test Set (IFR 6000). After tester performs Self Test, push SETUP button on the test set to bring up the SETUP-XPDR page. If necessary, continue pressing SETUP button until tester cycles to SETUP-XPDR page.

-
- (2) On the Transponder Test Set (IFR 6000) SETUP-XPDR page, use NEXT PARAM or PREV PARAM soft keys to select each parameter, and the “arrow” DATA keys to set the values listed below.
 - ANTENNA: BOTTOM
 - RF PORT: ANTENNA
 - ANT RANGE-TOP: 18 ft.
 - ANT HEIGHT-BOTTOM: 7 ft.
 - ANT RANGE-BOTTOM: 18 ft.
 - ANT HEIGHT-TOP: 1 ft.
 - DIR CABLE LOSS: Ignore
 - ANT CABLE: 1 ft.
 - ANT CABLE LOSS: As marked on blue cable (should be 0.1 dB)
 - ANT GAIN (dBi) - 1.03 GHz: As marked on test set antenna
 - ANT GAIN (dBi) - 1.09 GHz: As marked on test set antenna
 - UUT ADDRESS: AUTO
 - MANUAL AA: Ignore
 - DIVERSITY TEST: OFF
 - PWR LIM: FAR 43
 - CHECK CAP: YES
 - (3) Push XPDR button to go to the XPDR-AUTO TEST page.
 - (4) Push CONFIG soft key to display the XPDR-CONFIG SCREEN page.
 - (5) On the XPDR-CONFIG SCREEN, scroll to GENERIC MODE S using the up/down DATA keys.
 - (6) With GENERIC MODE S highlighted, push RETURN soft key to confirm selection. This will also cause a return to the XPDR-AUTO TEST page.
 - (7) Set the WOW Box Switches to W-off-W (airborne).
 - (8) Push RUN TEST soft key to start AUTO TEST. The tester will sequence through separate tests, after which a “PASS” message should be displayed.

- (9) Bottom ERP should be between 48 to 60 dBm and MTL should be between -68 to -80 dBm to PASS.

NOTE: If values are obtained and any of the individual tests FAIL during AUTO TEST, press TEST LIST button on IFR 6000 and using UP/DOWN buttons scroll to the specific Failed test(s). Press SELECT TEST button, adjust IFR 6000 test set positioning anywhere within a 30 foot arc between the aircraft's right wingtip and the nose as required, and Press RUN TEST button until PASS Message is received (this may take several test set position adjustments until IFR 6000 and aircraft Transponder "Sync up"). Press STOP TEST button. Repeat until all individual FAILED tests have achieved a PASS. It is not necessary to re-run AUTO TEST. AUTO TEST is a convenience feature only.

NOTE: If POWER/FREQ test Fails: After pressing RUN TEST, adjust IFR-6000 test set positioning while test is running until PASS message appears (this test performs a "Live" update of the dBm values). It may be required to position the test set anywhere within a 30 foot arc between the aircraft's right wingtip and the nose. Press the STOP TEST button as soon as PASS message is displayed.

- (10) Make sure the following appears on the Transponder Test Set (IFR 6000):

- "A CODE" = transponder code entered
- "C ALT" = left PFD altitude indication +/- 100 ft.
- "S CODE" = ICAO code assigned to this aircraft/tail number
- "TAIL" = tail number assigned to this aircraft
- "FLT ID" = same as tail number
- "DF17 DETECTED" = YES (IF ADS-B OUT IS INSTALLED) / NO (IF ADS-B OUT IS NOT INSTALLED)
- "AA" = ICAO code assigned to this aircraft/tail number (8 digit number in parenthesis)
- "FS" = IN-AIR
- "VS" = IN-AIR

- (11) On MFD, press SYS along bottom of MFD. Use the small lower knob on the MFD to scroll to the SETUP page. On the SETUP page, press the SETTINGS softkey to bring up the SETTINGS page. At the bottom of the SETTINGS page, check:

- (a) The "REGISTRATION NO" number (alphanumeric) matches the "TAIL" number (alphanumeric) displayed on the IFR 6000 (above).

- (12) The “ICAO 24-BIT (OCT)” number matches the “AA” ICAO 24-bit code displayed on the IFR 6000 (above).

NOTE: If the aircraft’s registration number and/or ICAO 24-bit (octal) number are not present on the MFD’s SETTINGS page, the Aircraft Configuration File must be updated, refer to [AMM-31-40-00-051-801 – Aircraft Computer Systems - Maintenance Practices](#).

- (13) On the MFD, scroll to the SETUP tab, press the SENSOR Soft Key. Set the ADC PFD source selection from AUTO to ADC 2.
- (14) On the IFR 6000, press the XPDR button once.
- (15) Once XPDR – ALT ENCODER is displayed, press the SOURCE SELECT Soft Key until SOURCE - XPDR is displayed. Press the RUN TEST Soft Key.
- (16) Make sure an altitude reported on IFR 6000 matches L PFD altitude indication +/- 100 ft.
- (17) On the MFD, set the ADC source back to AUTO.

Set the WOW Box Switches to W-on-W (on-ground).

- (19) Set XPDR 2 to STANDBY MODE.

6. Diversity Transponder–1 Adjustment/Tests

SUBTASK AMM-34-50-20-071-B-701-003

A. Begin adjustment/test as follows:

- (1) Install Antenna Clamp and Shield Assembly (part of Transponder Test Set IFR 6000) on lower transponder antenna (bottom of the center cabin/fuselage), in accordance with instructions in IFR 6000 Ramp Test Set Operation Manual.
- (a) Position Antenna Clamp inside the slot in the Antenna Shield Plate, aligning captive screws into the respective screw holes.
- (b) Tighten captive screws.
- (c) Cover the transponder's Antenna with Antenna Shield. Loosen thumbscrews if necessary.
- NOTE:** It may be necessary to remove the unit under test's Antenna Guard if access to the transponders Antenna is restricted.
- (d) Secure Antenna Shield by tightening thumbscrews.
- (2) Perform job setup, refer to [SUBTASK AMM-34-50-20-071-B-921-001](#).
- (3) Push ECB BY SYSTEM soft key. Scroll to FLCSS using outer knob. Push inner knob to select. Scroll to the listed ECB using outer knob and highlight. Push “COLLAR” soft key. Push “CONFIRM COLLAR” soft key.
- ECB - NOSE LDG GEAR (L AFT Bus)
 - ECB - L MAIN LDG GEAR (L AFT Bus)

- ECB - R MAIN LDG GEAR (L AFT Bus)
- (4) Scroll to ENGINE using outer knob. Push inner knob to select. Scroll to the listed ECB using outer knob and highlight. Push “COLLAR” soft key. Push “CONFIRM COLLAR” soft key.
- ECB - L ENG FIRE EXTNGR (L FWD Bus)
 - ECB - R ENG FIRE EXTNGR (R FWD Bus)
- (5) Clear any “MASTER CAUTIONS” and “MASTER WARNINGS” as needed.
- (6) Set both left and right PFD baro set to 29.92 (in/Hg.) on Autopilot Control Panel (ACP) by pushing BARO SET knob.
- Make sure Baro Set on PFD annunciates “29.92 IN”.
- B. Diversity Transponder-1 Setup
- (1) Use the small rotary knob on the left PFD to select XPDR page.
- NOTE: The XPDR select page times out and switches back to the COM page after 30 seconds. Select XPDR page from time to time during this test.
- (2) Push ACTIVE soft key (upper right button) on the left PFD to select D-XPDR1.
- (3) Ensure the selected transponder is in Standby Mode.
- (4) Push CODE soft key on left PFD and enter the transponder code used for this test or 1200.
- (5) Make sure the selected transponder is in Standby Mode.
- C. Diversity Transponder-1 MODE A,C,S Test using Transponder Test Set, IFR6000 (Upper Antenna)
- (1) Power up the Transponder Test Set (IFR 6000). After tester performs Self Test, push SETUP button on the test set to bring up the SETUP-XPDR page. If necessary, continue pressing SETUP button until tester cycles to SETUP-XPDR page.
- (2) On the Transponder Test Set (IFR 6000)’s SETUP-XPDR page, use NEXT PARAM or PREV PARAM soft keys to select each parameter, and the “arrow” DATA keys to set the values listed below.
- ANTENNA: TOP
 - RF PORT: ANTENNA
 - ANT RANGE-TOP: 18 ft.
 - ANT HEIGHT-TOP: 7 ft.
 - ANT RANGE-BOTTOM: 18 ft.
 - ANT HEIGHT-BOTTOM: 1 ft.
 - DIR CABLE LOSS: Ignore
 - ANT CABLE: 1 ft.

- ANT CABLE LOSS: As marked on blue cable (should be 0.1 dB)
 - ANT GAIN (dBi) - 1.03 GHz: As marked on test set antenna
 - ANT GAIN (dBi) - 1.09 GHz: As marked on test set antenna
 - UUT ADDRESS: AUTO
 - MANUAL AA: Ignore
 - DIVERSITY TEST: ON
 - PWR LIM: FAR 43
 - CHECK CAP: YES
- (3) Push XPDR button to go to the XPDR-AUTO TEST page.
- (4) Push CONFIG soft key to display the XPDR-CONFIG SCREEN page.
- (5) On the XPDR-CONFIG SCREEN, scroll to GENERIC MODE S using the UP/Down DATA keys.
- (6) With GENERIC MODE S highlighted, push RETURN soft key to confirm selection. This will also cause a return to the XPDR-AUTO TEST page.
- (7) Set the WOW Box Switches to W-off-W (airborne).
- (8) Push RUN TEST soft key to start AUTO TEST. The tester will sequence through separate tests, after which a “PASS” message should be displayed.
- (9) Top ERP should be between 48 to 60 dBm and MTL should be between -68 to -80 dBm to PASS.

NOTE: If values are obtained and any of the individual tests FAIL during AUTO TEST, press TEST LIST button on IFR 6000 and using UP/DOWN buttons scroll to the specific Failed test(s). Press SELECT TEST button, adjust IFR 6000 test set positioning anywhere within a 30 foot arc between the aircraft’s right wingtip and the nose as required, and Press RUN TEST button until PASS Message is received (this may take several test set position adjustments until IFR 6000 and aircraft Transponder “Sync up”). Press STOP TEST button. Repeat until all individual FAILED tests have achieved a PASS. It is not necessary to re-run AUTO TEST. AUTO TEST is a convenience feature only.

NOTE: If POWER/FREQ test Fails: After pressing RUN TEST, adjust IFR-6000 test set positioning while test is running until PASS message appears (this test performs a “Live” update of the dBm values). It may be required to position the test set anywhere within a 30 foot arc between the aircraft’s right wingtip and the nose. Press the STOP TEST button as soon as PASS message is displayed

- (10) Make sure the following appears on the Transponder Test Set (IFR 6000):
- “A CODE” = transponder code entered
 - “C ALT” = left PFD altitude indication +/- 100 ft.

- “S CODE” = ICAO code assigned to this aircraft/tail number
 - “TAIL” = tail number assigned to this aircraft
 - “FLT ID” = same as tail number
 - “DF17 DETECTED” = YES (IF ADS-B OUT IS INSTALLED) / NO (IF ADS-B OUT IS NOT INSTALLED)
 - “AA” = ICAO code assigned to this aircraft/tail number (8 digit number in parenthesis)
 - “FS” = IN-AIR
 - “VS” = IN-AIR
- (11) On MFD, press SYS along bottom of MFD. Use the small lower knob on the MFD to scroll to the SETUP page. On the SETUP page, press the SETTINGS soft key to bring up the SETTINGS page. At the bottom of the SETTINGS page, check:
- (a) The “REGISTRATION NO” number (alphanumeric) matches the “TAIL” number (alphanumeric) displayed on the IFR 6000 (above).
 - (b) The “ICAO 24-BIT (OCT)” number matches the “AA” ICAO 24-bit code displayed on the IFR 6000 (above).
- NOTE:** If the aircraft’s registration number and/or ICAO 24-bit (octal) number are not present on the MFD’s SETTINGS page, the Aircraft Configuration File must be updated, refer to [AMM-31-40-00-051-801 – Aircraft Computer Systems - Maintenance Practices](#). Steps (14) through this step must then be repeated.
- (12) On the MFD, scroll to the SETUP tab, press the SENSOR Soft Key. Set the ADC PFD source selection from AUTO to ADC 2.
- (13) On the IFR 6000, press the XPDR button once.
- (14) Once XPDR – ALT ENCODER is displayed, press the SOURCE SELECT Soft Key until SOURCE - XPDR is displayed. Press the RUN TEST Soft Key.
- (15) Make sure an altitude reported on IFR 6000 matches L PFD altitude indication +/- 100 ft.
- (16) On the MFD, set the ADC source back to AUTO.
- (17) Set the WOW Box Switches to W-on-W (on-ground).
- (18) Set D-XPDR 1 to STANDBY MODE.
- D. Diversity Transponder-1 MODE A,C,S Test using Transponder Test Set (IFR 6000) (Lower Antenna)
- (1) Remove Antenna Clamp and Shield Assembly (part of Transponder Test Set IFR 6000) from lower transponder antenna (bottom of the center cabin/fuselage).
 - (2) Install Antenna Clamp and Shield Assembly (part of Transponder Test Set IFR 6000) on upper transponder antenna (top of the center cabin/fuselage), in accordance with instructions in IFR 6000 Ramp Test Set Operation Manual.

- (3) Pre-position the Transponder Test Set IFR 6000 antenna to point at the aircraft's lower Transponder 2 antenna (bottom of the center cabin/fuselage)..
- (4) Push XPDR button to go to the XPDR-AUTO TEST page.
- (5) Push CONFIG soft key to display the XPDR-CONFIG SCREEN page.
- (6) On the XPDR-CONFIG SCREEN, scroll to GENERIC MODE S using the UP/Down DATA keys.
- (7) With GENERIC MODE S highlighted, push RETURN soft key to confirm selection. This will also cause a return to the XPDR-AUTO TEST page.
- (8) Set the WOW Box Switches to W-off-W (airborne).
- (9) Push RUN TEST soft key to start AUTO TEST. The tester will sequence through separate tests, after which a "PASS" message should be displayed.
- (10) Bottom ERP should be between 48 to 60 dBm and MTL should be between -68 to -80 dBm to PASS.

NOTE: If values are obtained and any of the individual tests FAIL during AUTO TEST, press TEST LIST button on IFR 6000 and using UP/DOWN buttons scroll to the specific Failed test(s). Press SELECT TEST button, adjust IFR 6000 test set positioning anywhere within a 30 foot arc between the aircraft's right wingtip and the nose as required, and Press RUN TEST button until PASS Message is received (this may take several test set position adjustments until IFR 6000 and aircraft Transponder "Sync up"). Press STOP TEST button. Repeat until all individual FAILED tests have achieved a PASS. It is not necessary to re-run AUTO TEST. AUTO TEST is a convenience feature only.

NOTE: If POWER/FREQ test Fails: After pressing RUN TEST, adjust IFR-6000 test set positioning while test is running until PASS message appears (this test performs a "Live" update of the dBm values). It may be required to position the test set anywhere within a 30 foot arc between the aircraft's right wingtip and the nose. Press the STOP TEST button as soon as PASS message is displayed

- (11) Remove Antenna Clamp and Shield Assembly.
- (12) Set the WOW Box Switches to W-on-W (on-ground).

7. Diversity Transponder-2 Adjustment/Tests

SUBTASK AMM-34-50-20-071-B-701-004

A. Begin adjustment/test as follows:

- (1) Install Antenna Clamp and Shield Assembly (part of Transponder Test Set IFR 6000) on lower transponder antenna (bottom of the center cabin/fuselage), in accordance with instructions in IFR 6000 Ramp Test Set Operation Manual.

- (a) Position Antenna Clamp inside the slot in the Antenna Shield Plate, aligning captive screws into the respective screw holes.
- (b) Tighten captive screws.
- (c) Cover the transponder's Antenna with Antenna Shield. Loosen thumbscrews if necessary.

NOTE: It may be necessary to remove the unit under test's Antenna Guard if access to the transponders Antenna is restricted.

- (d) Secure Antenna Shield by tightening thumbscrews.

- (2) Perform job setup, refer to [SUBTASK AMM-34-50-20-071-B-921-001](#).
- (3) Push ECB BY SYSTEM soft key. Scroll to FLCSS using outer knob. Push inner knob to select. Scroll to the listed ECB using outer knob and highlight. Push "COLLAR" soft key. Push "CONFIRM COLLAR" soft key.
 - ECB - NOSE LDG GEAR (L AFT Bus)
 - ECB - L MAIN LDG GEAR (L AFT Bus)
 - ECB - R MAIN LDG GEAR (L AFT Bus)
- (4) Scroll to ENGINE using outer knob. Push inner knob to select. Scroll to the listed ECB using outer knob and highlight. Push "COLLAR" soft key. Push "CONFIRM COLLAR" soft key.
 - ECB - L ENG FIRE EXTNGR (L FWD Bus)
 - ECB - R ENG FIRE EXTNGR (R FWD Bus)
- (5) Clear any "MASTER CAUTIONS" and "MASTER WARNINGS" as needed.
- (6) Set both left and right PFD baro set to 29.92 (in/Hg.) on Autopilot Control Panel (ACP) by pushing BARO SET knob.
 - Make sure that Baro Set on PFD annunciates "29.92 IN".

B. Diversity Transponder-2 Setup

- (1) Use the small rotary knob on the left PFD to select XPDR page.

NOTE: The XPDR select page times out and switches back to the COM page after 30 seconds. Select XPDR page from time to time during this test.
- (2) Push ACTIVE soft key (upper right button) on the left PFD to select D-XPDR2.
- (3) Make sure that D-XPDR2 is in Standby Mode.
- (4) Push CODE soft key on left PFD and enter the transponder code used for this test or 1200.

C. Diversity Transponder-2 MODE A,C,S Test using Transponder Test Set, IFR6000 (Upper Antenna)

- (1) Power up the Transponder Test Set (IFR 6000). After tester performs Self Test, push SETUP button on the test set to bring up the SETUP-XPDR page. If necessary, continue pressing SETUP button until tester cycles to SETUP-XPDR page.
- (2) On the Transponder Test Set (IFR 6000)'s SETUP-XPDR page, use NEXT PARAM or PREV PARAM soft keys to select each parameter, and the "arrow" DATA keys to set the values listed below.
 - ANTENNA: TOP
 - RF PORT: ANTENNA
 - ANT RANGE-TOP: 18 ft.
 - ANT HEIGHT-TOP: 7 ft.
 - ANT RANGE-BOTTOM: 18 ft.
 - ANT HEIGHT-BOTTOM: 1 ft.
 - DIR CABLE LOSS: Ignore
 - ANT CABLE: 1 ft.
 - ANT CABLE LOSS: As marked on blue cable (should be 0.1 dB)
 - ANT GAIN (dBi) - 1.03 GHz: As marked on test set antenna
 - ANT GAIN (dBi) - 1.09 GHz: As marked on test set antenna
 - UUT ADDRESS: AUTO
 - MANUAL AA: Ignore
 - DIVERSITY TEST: ON
 - PWR LIM: FAR 43
 - CHECK CAP: YES
- (3) Push XPDR button to go to the XPDR-AUTO TEST page.
- (4) Push CONFIG soft key to display the XPDR-CONFIG SCREEN page.
- (5) On the XPDR-CONFIG SCREEN, scroll to GENERIC MODE S using the UP/Down DATA keys.
- (6) With GENERIC MODE S highlighted, push RETURN soft key to confirm selection. This will also cause a return to the XPDR-AUTO TEST page.
- (7) Set the WOW Box Switches to W-off-W (airborne).
- (8) Push RUN TEST soft key to start AUTO TEST. The tester will sequence through separate tests, after which a "PASS" message should be displayed.

- (9) Top ERP should be between 48 to 60 dBm and MTL should be between -68 to -80 dBm to PASS.

NOTE: If values are obtained and any of the individual tests FAIL during AUTO TEST, press TEST LIST button on IFR 6000 and using UP/DOWN buttons scroll to the specific Failed test(s). Press SELECT TEST button, adjust IFR 6000 test set positioning anywhere within a 30 foot arc between the aircraft's right wingtip and the nose as required, and Press RUN TEST button until PASS Message is received (this may take several test set position adjustments until IFR 6000 and aircraft Transponder "Sync up"). Press STOP TEST button. Repeat until all individual FAILED tests have achieved a PASS. It is not necessary to re-run AUTO TEST. AUTO TEST is a convenience feature only.

NOTE: If POWER/FREQ test Fails: After pressing RUN TEST, adjust IFR-6000 test set positioning while test is running until PASS message appears (this test performs a "Live" update of the dBm values). It may be required to position the test set anywhere within a 30 foot arc between the aircraft's right wingtip and the nose. Press the STOP TEST button as soon as PASS message is displayed

- (10) Make sure the following appears on the Transponder Test Set (IFR 6000):

- "A CODE" = transponder code entered
- "C ALT" = left PFD altitude indication +/- 100 ft.
- "S CODE" = ICAO code assigned to this aircraft/tail number
- "TAIL" = tail number assigned to this aircraft
- "DF17 DETECTED" = YES (IF ADS-B OUT IS INSTALLED) / NO (IF ADS-B OUT IS NOT INSTALLED)
- "FLT ID" = same as tail number
- "AA" = ICAO code assigned to this aircraft/tail number (8 digit number in parenthesis)
- "FS" = IN-AIR
- "VS" = IN-AIR

- (11) On MFD, press SYS along bottom of MFD. Use the small lower knob on the MFD to scroll to the SETUP page. On the SETUP page, press the SETTINGS softkey to bring up the SETTINGS page. At the bottom of the SETTINGS page, check:

- (a) The "REGISTRATION NO" number (alphanumeric) matches the "TAIL" number (alphanumeric) displayed on the IFR 6000 (above).

- (b) The “ICAO 24-BIT (OCT)” number matches the “AA” ICAO 24-bit code displayed on the IFR 6000 (above).

NOTE: If the aircraft’s registration number and/or ICAO 24-bit (octal) number are not present on the MFD’s SETTINGS page, the Aircraft Configuration File must be updated, refer to [AMM-31-40-00-051-801 – Aircraft Computer Systems - Maintenance Practices](#). Steps (14) through this step must then be repeated.

- (12) On the MFD, scroll to the SETUP tab, press the SENSOR Soft Key. Set the ADC PFD source selection from AUTO to ADC 2.
 - (13) On the IFR 6000, press the XPDR button once.
 - (14) Once XPDR – ALT ENCODER is displayed, press the SOURCE SELECT Soft Key until SOURCE - XPDR is displayed. Press the RUN TEST Soft Key.
 - (15) Make sure that an altitude reported on IFR 6000 matches L PFD altitude indication +/- 100 ft.
 - (16) On the MFD, set the ADC source back to AUTO.
 - (17) Set the WOW Box Switches to W-on-W (on-ground).
 - (18) Set D-XPDR 2 to STANDBY MODE.
- D. Diversity Transponder-2 MODE A,C,S Test using Transponder Test Set (IFR 6000) (Lower Antenna)
- (1) Remove Antenna Clamp and Shield Assembly (part of Transponder Test Set IFR 6000) from lower transponder antenna (bottom of the center cabin/fuselage).
 - (2) Install Antenna Clamp and Shield Assembly (part of Transponder Test Set IFR 6000) on upper transponder antenna (top of the center cabin/fuselage), in accordance with instructions in IFR 6000 Ramp Test Set Operation Manual.
 - (3) Pre-position the Transponder Test Set IFR 6000 antenna to point at the aircraft’s lower Transponder 2 antenna (bottom of the center cabin/fuselage)
 - (4) On the Transponder Test Set (IFR 6000) SETUP-XPDR page, use NEXT PARAM or PREV PARAM softkeys to select each parameter, and the “arrow” DATA keys to set the values listed below:
 - ANTENNA: BOTTOM
 - RF PORT: ANTENNA
 - ANT RANGE-TOP: 18 ft.
 - ANT HEIGHT-TOP: 7 ft.
 - ANT RANGE-BOTTOM: 18 ft.
 - ANT HEIGHT-BOTTOM: 1 ft.
 - DIR CABLE LOSS: Ignore
 - ANT CABLE: 1 ft.
 - ANT CABLE LOSS: As marked on blue cable (should be 0.1 dB)

- ANT GAIN (dBi) - 1.03 GHz: As marked on test set antenna
 - ANT GAIN (dBi) - 1.09 GHz: As marked on test set antenna
 - UUT ADDRESS: AUTO
 - MANUAL AA: Ignore
 - DIVERSITY TEST: ON
 - PWR LIM: FAR 43
 - CHECK CAP: YES
- (5) Push XPDR button to go to the XPDR-AUTO TEST page.
 - (6) Push CONFIG soft key to display the XPDR-CONFIG SCREEN page.
 - (7) On the XPDR-CONFIG SCREEN, scroll to GENERIC MODE S using the UP/Down DATA keys.
 - (8) With GENERIC MODE S highlighted, push RETURN soft key to confirm selection. This will also cause a return to the XPDR-AUTO TEST page.
 - (9) Set the WOW Box Switches to W-off-W (airborne).
 - (10) Push RUN TEST soft key to start AUTO TEST. The tester will sequence through 17 separate tests, after which a “PASS” message should be displayed.
 - (11) Bottom ERP should be between 48 to 60 dBm and MTL should be between -68 to -80 dBm to PASS.

NOTE: If values are obtained and any of the individual tests FAIL during AUTO TEST, press TEST LIST button on IFR 6000 and using UP/DOWN buttons scroll to the specific Failed test(s). Press SELECT TEST button, adjust IFR 6000 test set positioning anywhere within a 30 foot arc between the aircraft’s right wingtip and the nose as required, and Press RUN TEST button until PASS Message is received (this may take several test set position adjustments until IFR 6000 and aircraft Transponder “Sync up”). Press STOP TEST button. Repeat until all individual FAILED tests have achieved a PASS. It is not necessary to re-run AUTO TEST. AUTO TEST is a convenience feature only.

NOTE: If POWER/FREQ test Fails: After pressing RUN TEST, adjust IFR-6000 test set positioning while test is running until PASS message appears (this test performs a “Live” update of the dBm values). It may be required to position the test set anywhere within a 30 foot arc between the aircraft’s right wingtip and the nose. Press the STOP TEST button as soon as PASS message is displayed

- (12) Remove Antenna Clamp and Shield Assembly from aircraft and stow in IFR 6000 ramp test set kit.
- (13) Remove Antenna Clamp and Shield Assembly and stow in ramp test kit.
- (14) Set the WOW Box Switches to W-on-W (on-ground).

8. Job Close-Up

SUBTASK AMM-34-50-20-071-B-921-002

- A. Set WOW Box switches to W-on-W
- B. Reset the collared ECB's. Refer to AMM-20-00-03-051-801 – Prepare Anti-Ice Systems For Maintenance.
- C. Scroll to FLCs using outer knob. Press inner knob to select. Scroll to the listed ECB using outer knob and highlight. Push “RESET” Soft key. Press “CONFIRM RESET” soft key.
 - ECB - NOSE LDG GEAR (L AFT Bus)
 - ECB - L MAIN LDG GEAR (L AFT Bus)
 - ECB - R MAIN LDG GEAR (L AFT Bus)
- D. Scroll to ENGINE using outer knob. Press inner knob to select. Scroll to the listed ECB using outer knob and highlight. Push “RESET” Soft key. Press “CONFIRM RESET” soft key.
 - ECB - L ENG FIRE EXTNGR (L FWD Bus)
 - ECB - R ENG FIRE EXTNGR (R FWD Bus)
- E. Power down the aircraft by setting the SYS BATT and START BATT switches to OFF and the BUS TIE to OPEN.
- F. Disconnect WOW Box from aircraft. Refer to AMM-20-00-04-051-801 – Weight On Wheels (WOW) Box - Connect/Disconnect.
- G. If on jacks, lower aircraft and remove jacks. Refer to [AMM-07-10-00-051-801 – Jacking - Maintenance Practices](#).
- H. If applicable, call the local control tower and tell them the transponder test is complete.
- I. Remove all tools, equipment and unwanted material from work area.
- J. Disconnect external power. Refer to [AMM-24-40-00-051-801 – External Power - Maintenance Practices](#).
- K. If all other maintenance is complete, return aircraft to service. Refer to [AMM-20-00-02-051-801 – Return To Service \(After Maintenance\)](#).

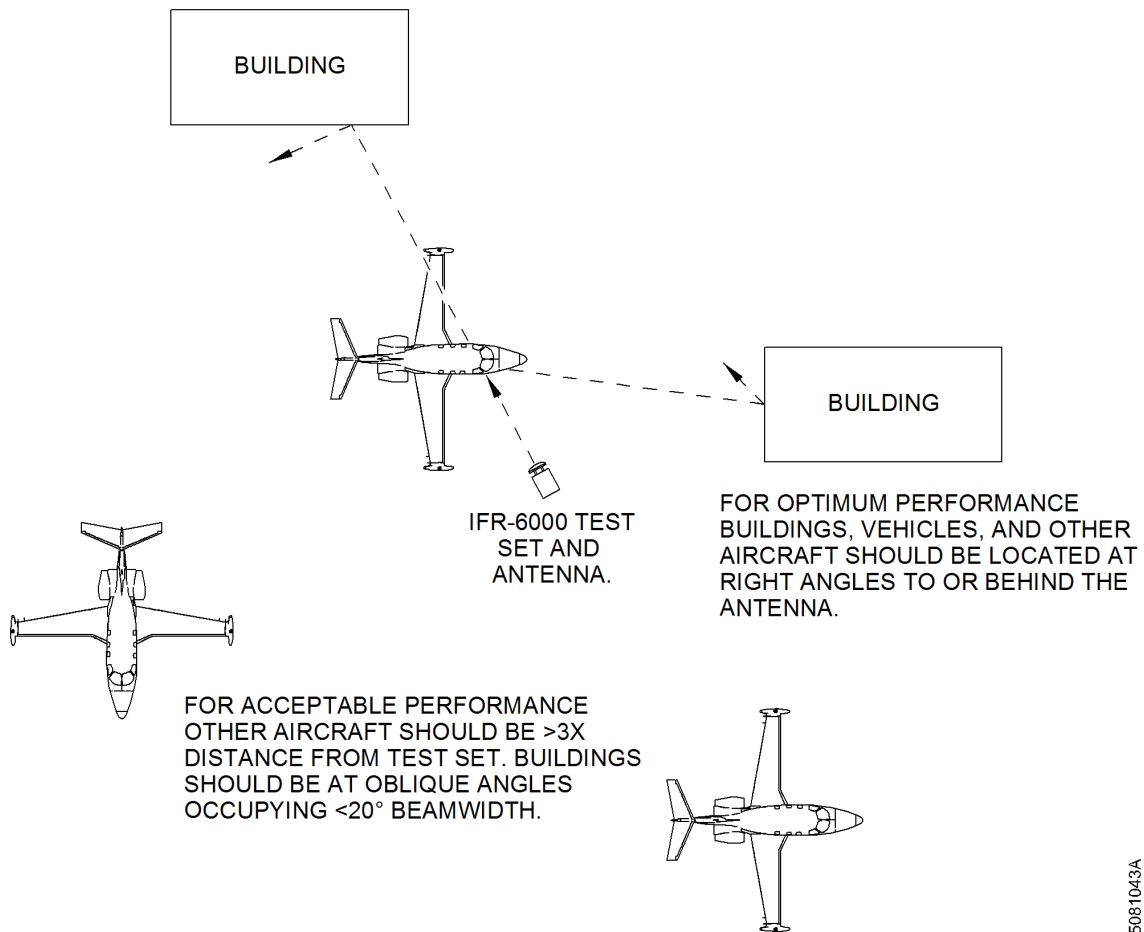
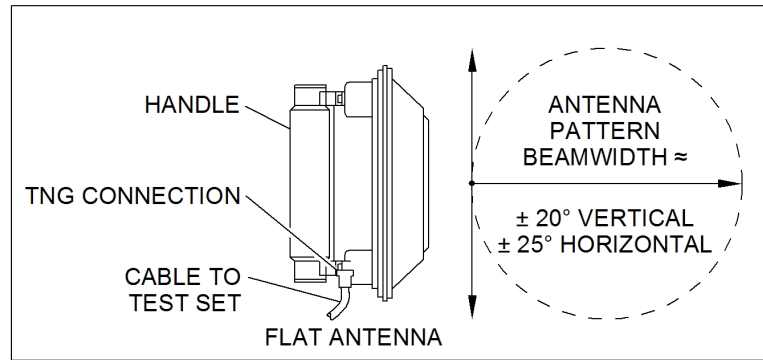

5081043A

**Transponder - Adjustment/Test
Figure 501 (Sheet 1 of 1)**

TRANSPONDER - ADJUSTMENT/TEST

AMM-34-50-20-071-C-801

1. General

A. This task gives procedures to do the adjustment/test of the:

- Dual Standard (Non-Diversity) Transponder System and components or Optional Dual Diversity Transponder System and components.
- An adjustment/test is only required for the transponder that is being installed. The opposite transponder, if it has not been removed, does not require an adjustment/test

NOTE: ADS-B test is only required, if the ADS-B function is enabled.

 (1) Refer to [Table 501](#) for testing procedures.

Table 501. Test Matrix

System Test	Procedures
Dual Standard Transponder System Test	Std. Transponder 1 Adjustment/Test: SUBTASK AMM-34-50-20-071-C-701-001 , and Std. Transponder 2 Adjustment/Test: SUBTASK AMM-34-50-20-071-C-701-002 . ADS-B Adjustment Test: (If installed) AMM-34-50-21-071-801 – ADS-B - Adjustment/Test . Transponder Cooling Adjustment/Test: TASK AMM-34-50-24-071-801 .
Dual Diversity Transponder System Test	Diversity Transponder 1 Adjustment/Test: SUBTASK AMM-34-50-20-071-C-701-003 , and Diversity Transponder 2 Adjustment/Test: SUBTASK AMM-34-50-20-071-C-701-004 . ADS-B Adjustment Test: (If installed) AMM-34-50-21-071-801 – ADS-B - Adjustment/Test . Transponder Cooling Adjustment/Test: TASK AMM-34-50-24-071-801 .

2. Equipment and Materials

A. Special Tools and Equipment

Name and Part Number
Transponder Test Set (Aeroflex, IFR6000) or equivalent

Name and Part Number
Weight-on-Wheels (WOW) Box (EAI, 87-117390-1001) or AMC 2.4.01 (or higher).
Ground Power Unit (GPU). AllStar 450 or AllStar G.S.E. or Hobart GPU-400 or Hobart GPU-600 or Bycan PS-28100

3. Job Set-Up

SUBTASK AMM-34-50-20-071-C-921-001

- A. Make aircraft safe for maintenance. Refer to [AMM-20-00-01-051-801 – Make Safe For Maintenance](#).
- B. If on jacks, refer to [AMM-07-10-00-051-801 – Jacking - Maintenance Practices](#) and [AMM-08-20-00-051-801 – Leveling](#).
- C. Connect external power. Refer to [AMM-24-40-00-051-801 – External Power - Maintenance Practices](#). Do not turn on START BATT and SYS BATT switches until prompted.
- D. Prepare Anti-ice system for maintenance. Refer to [AMM-20-00-03-051-801 – Prepare Anti-Ice Systems For Maintenance](#).
- E. Take proper safety precautions to protect personnel. Position aircraft such that multi-path RF reflections between the IFR-6000 test set, the aircraft's antennas, and surrounding objects are minimized. The area on the left side of the aircraft should not be up against a metal wall or another aircraft. If necessary, position the aircraft outside, away from metal buildings or other aircraft. Refer to [Fig. 501](#).

CAUTION: FAILURE TO COMPLY WITH THIS STEP AND CONTINUING WITH THIS PROCEDURE COULD IMPACT LOCAL AIRPORT TOWER OPERATIONS.

- F. If applicable, contact local airport tower to inform them a transponder test is being run at your location (inside or outside). Request appropriate squawk and allotted time to run test.

NOTE: If local airport tower is not informed, use code 1200.

- G. Attach test set antenna to Transponder Test Set using 1 foot long test set cable (blue cable, supplied if IFR6000 is used), connected to ANT port on tester.
- H. During testing, place the Transponder Test Set antenna approximately two feet to four feet forward and in line with right wing tip tank. May require periodic repositioning between two and four feet.
- I. Connect Weight On Wheels (WOW) box or Aircraft Maintenance Computer (AMC) and set switches on Box to W-On-W (on-ground). Refer to [AMM-20-00-04-051-801 – Weight On Wheels \(WOW\) Box - Connect/Disconnect](#).

4. Transponder-1 Adjustment/Test (Standard System)

SUBTASK AMM-34-50-20-071-C-701-001

A. Begin adjustment/test as follows:

- (1) Perform job setup, refer to [SUBTASK AMM-34-50-20-071-C-921-001](#).
- (2) Re-align the Transponder Test Set, IFR6000 antenna to point at the aircraft's Transponder-1 antenna (top of the center cabin/fuselage).
- (3) Use the small rotary knob on the left PFD to select XPDR page. NOTE: The XPDR select page will time out and switch back to the COM page after 30 seconds. The operator will have to select XPDR page from time to time during this test.
- (4) Make sure that Transponder 1 (XPDR 1) is ACTIVE transponder in STANDBY MODE.
- (5) Scroll to FLT CTRLS using outer knob. Push inner knob to select. Scroll to the listed ECB using outer knob and highlight. Push "COLLAR" soft key. Push "CONFIRM COLLAR" soft key.
 - ECB - NOSE LDG GEAR (L AFT Bus)
 - ECB - L MAIN LDG GEAR (L AFT Bus)
 - ECB - R MAIN LDG GEAR (L AFT Bus)
- (6) Scroll to ENGINE using outer knob. Push inner knob to select. Scroll to the listed ECB using outer knob and highlight. Push "COLLAR" soft key. Push "CONFIRM COLLAR" soft key.
 - ECB - L ENG FIRE EXTNGR (L FWD Bus)
 - ECB - R ENG FIRE EXTNGR (R FWD Bus)
- (7) Clear any "MASTER CAUTIONS" and "MASTER WARNINGS" as needed.
- (8) Set both left and right PFD baro set to 29.92 (in/Hg) on Autopilot Control Panel (ACP) by pushing BARO SET knob.

B. Transponder-1 Setup

- (1) Use the small rotary knob on the left PFD to select XPDR page.
NOTE: The XPDR select page times out and switches back to the COM page after 30 seconds. Select XPDR page from time to time during this test.
- (2) Make sure that Transponder 1 (XPDR 1) is selected as ACTIVE transponder in STANDBY MODE.
- (3) Push CODE soft key on left PFD and enter the transponder code provided by the control tower for this test. If no code was assigned, enter 1200.

C. Transponder-1 MODE A,C,S Test using Transponder Test Set, IFR6000

- (1) Power up the Transponder Test Set (IFR 6000). After tester performs Self Test, push SETUP button on the test set to bring up the SETUP-XPDR page. If necessary, continue pressing SETUP button until tester cycles to SETUP-XPDR page.
- (2) On the Transponder Test Set (IFR 6000)'s SETUP-XPDR page, use NEXT PARAM or PREV PARAM soft keys to select each parameter, and the "arrow" DATA keys to set the values listed below.
 - ANTENNA: TOP
 - RF PORT: ANTENNA
 - ANT RANGE-TOP: 18 ft.
 - ANT HEIGHT-TOP: 7 ft.
 - ANT RANGE-BOTTOM: 18 ft.
 - ANT HEIGHT-BOTTOM: 1 ft.
 - DIR CABLE LOSS: Ignore
 - ANT CABLE: 1 ft.
 - ANT CABLE LOSS: As marked on blue cable (should be 0.1 dB)
 - ANT GAIN (dBi) - 1.03 GHz: As marked on test set antenna
 - ANT GAIN (dBi) - 1.09 GHz: As marked on test set antenna
 - UUT ADDRESS: AUTO
 - MANUAL AA: Ignore
 - DIVERSITY TEST: OFF
 - PWR LIM: FAR 43
 - CHECK CAP: YES
- (3) Push XPDR button to go to the XPDR-AUTO TEST page.
- (4) Push CONFIG soft key to display the XPDR-CONFIG SCREEN page.
- (5) On the XPDR-CONFIG SCREEN, scroll to GENERIC MODE S using the UP/Down DATA keys.
- (6) With GENERIC MODE S highlighted, push RETURN soft key to confirm selection. This will also cause a return to the XPDR-AUTO TEST page.
- (7) Set the WOW test box or AMC to W-off-W (airborne).

NOTE: Transponders will transition to ALT mode automatically when airborne or simulated airborne (W-off-W).
- (8) Push RUN TEST soft key to start AUTO TEST. The tester will sequence through separate tests, after which a "PASS" message should be displayed.

- (9) Top ERP should be between 48 to 60 dBm and MTL should be between -68 to -80 dBm to PASS.

NOTE: If values are obtained and any of the individual tests FAIL during AUTO TEST, press TEST LIST button on IFR 6000 and using UP/DOWN buttons scroll to the specific Failed test(s). Press SELECT TEST button, adjust IFR 6000 test set positioning anywhere within a 30 foot arc between the aircraft's right wingtip and the nose as required, and Press RUN TEST button until PASS Message is received (this may take several test set position adjustments until IFR 6000 and aircraft Transponder "Sync up"). Press STOP TEST button. Repeat until all individual FAILED tests have achieved a PASS. It is not necessary to re-run AUTO TEST. AUTO TEST is a convenience feature only.

NOTE: If POWER/FREQ test Fails: After pressing RUN TEST, adjust IFR-6000 test set positioning while test is running until PASS message appears (this test performs a "Live" update of the dBm values). It may be required to position the test set anywhere within a 30 foot arc between the aircraft's right wingtip and the nose. Press the STOP TEST button as soon as PASS message is displayed

- (10) Push RUN TEST soft key on Transponder Test Set (IFR 6000) again.
- (11) Make sure the following appears on the Transponder Test Set (IFR 6000):
- "A CODE" = transponder code entered
 - "C ALT" = left PFD altitude indication +/- 100 ft.
 - "S CODE" = ICAO code assigned to this aircraft/tail number
 - "TAIL" = tail number assigned to this aircraft
 - DF17 DETECTED = YES (IF ADS-B OUT IS INSTALLED) / NO (IF ADS-B OUT IS NOT INSTALLED)
 - "FLT ID" = same as tail number
 - "AA" = ICAO code assigned to this aircraft/tail number (8 digit number in parenthesis)
 - "FS" = IN-AIR
 - "VS" = IN-AIR
- (12) On MFD, press SYS along bottom of MFD. Use the small lower knob on the MFD to scroll to the SETUP page. On the SETUP page, press the SETTINGS softkey to bring up the SETTINGS page. At the bottom of the SETTINGS page, verify:
- (a) The "REGISTRATION NO" number (alphanumeric) matches the "TAIL" number (alphanumeric) displayed on the IFR 6000 (above).

- (b) The “ICAO 24-BIT (OCT)” number matches the “AA” ICAO 24-bit code displayed on the IFR 6000 (above).

NOTE: If the aircraft’s registration number and/or ICAO 24-bit (octal) number are not present on the MFD’s SETTINGS page, the Aircraft Configuration File must be updated, refer to [AMM-31-40-00-051-801 – Aircraft Computer Systems - Maintenance Practices](#). Steps (10) through this step must then be repeated.

- (13) On the MFD, scroll to the SETUP tab, press the SENSOR Soft Key. Set the ADC PFD source selection from AUTO to ADC 2.
- (14) On the IFR 6000, press the XPDR button once. Once XPDR – ALT ENCODER is displayed, press the SOURCE SELECT Soft Key until SOURCE - XPDR is displayed. Press the RUN TEST Soft Key.
- (15) Make sure that the altitude reported on IFR 6000 matches L PFD altitude indication +/- 100 ft.
- (16) On the MFD, set the ADC source back to AUTO.
- (17) Set the WOW Box Switches to W-on-W (on-ground).
- (18) Set XPDR 1 to STANDBY MODE.

5. **Transponder–2 Adjustment/Test (Standard System)**

SUBTASK AMM-34-50-20-071-C-701-002

A. Begin adjustment/test as follows:

- (1) Perform job setup, refer to [SUBTASK AMM-34-50-20-071-C-921-001](#).
- (2) Re-align the Transponder Test Set, IFR6000 antenna to point at the aircraft’s lower Transponder–2 antenna (bottom of the center cabin/fuselage).
- (3) Use the small rotary knob on the left PFD to select XPDR page.

NOTE: The XPDR select page will time out and switch back to the COM page after 30 seconds. The operator will have to select XPDR page from time to time during this test.

- (4) Push ACTIVE soft key, upper right button, on the left PFD to select XPDR 2.
- (5) Make sure that Transponder 2 (XPDR 2) is in STANDBY MODE.

B. Transponder-2 Setup

- (1) Push CODE soft key on right PFD and enter the transponder code provided by the control tower for this test. If no code was assigned, enter 1200.

C. Transponder-2 MODE A,C,S Test using Transponder Test Set, IFR6000

- (1) Power up the Transponder Test Set (IFR 6000). After tester performs Self Test, push SETUP button on the test set to bring up the SETUP-XPDR page. If necessary, continue pressing SETUP button until tester cycles to SETUP-XPDR page.

- (2) On the Transponder Test Set (IFR 6000) SETUP-XPDR page, use NEXT PARAM or PREV PARAM soft keys to select each parameter, and the “arrow” DATA keys to set the values listed below.
 - ANTENNA: BOTTOM
 - RF PORT: ANTENNA
 - ANT RANGE-TOP: 18 ft.
 - ANT HEIGHT-BOTTOM: 7 ft.
 - ANT RANGE-BOTTOM: 18 ft.
 - ANT HEIGHT-TOP: 1 ft.
 - DIR CABLE LOSS: Ignore
 - ANT CABLE: 1 ft.
 - ANT CABLE LOSS: As marked on blue cable (should be 0.1 dB)
 - ANT GAIN (dBi) - 1.03 GHz: As marked on test set antenna
 - ANT GAIN (dBi) - 1.09 GHz: As marked on test set antenna
 - UUT ADDRESS: AUTO
 - MANUAL AA: Ignore
 - DIVERSITY TEST: OFF
 - PWR LIM: FAR 43
 - CHECK CAP: YES
- (3) Push XPDR button to go to the XPDR-AUTO TEST page.
- (4) Push CONFIG soft key to display the XPDR-CONFIG SCREEN page.
- (5) On the XPDR-CONFIG SCREEN, scroll to GENERIC MODE S using the up/down DATA keys.
- (6) With GENERIC MODE S highlighted, push RETURN soft key to confirm selection. This will also cause a return to the XPDR-AUTO TEST page.
- (7) Set the WOW Box Switches to W-off-W (airborne).
- (8) Push RUN TEST soft key to start AUTO TEST. The tester will sequence through separate tests, after which a “PASS” message should be displayed.

- (9) Bottom ERP should be between 48 to 60 dBm and MTL should be between -68 to -80 dBm to PASS.

NOTE: If values are obtained and any of the individual tests FAIL during AUTO TEST, press TEST LIST button on IFR 6000 and using UP/DOWN buttons scroll to the specific Failed test(s). Press SELECT TEST button, adjust IFR 6000 test set positioning anywhere within a 30 foot arc between the aircraft's right wingtip and the nose as required, and Press RUN TEST button until PASS Message is received (this may take several test set position adjustments until IFR 6000 and aircraft Transponder "Sync up"). Press STOP TEST button. Repeat until all individual FAILED tests have achieved a PASS. It is not necessary to re-run AUTO TEST. AUTO TEST is a convenience feature only.

NOTE: If POWER/FREQ test Fails: After pressing RUN TEST, adjust IFR-6000 test set positioning while test is running until PASS message appears (this test performs a "Live" update of the dBm values). It may be required to position the test set anywhere within a 30 foot arc between the aircraft's right wingtip and the nose. Press the STOP TEST button as soon as PASS message is displayed.

- (10) Make sure the following appears on the Transponder Test Set (IFR 6000):
- "A CODE" = transponder code entered
 - "C ALT" = left PFD altitude indication +/- 100 ft.
 - "S CODE" = ICAO code assigned to this aircraft/tail number
 - "TAIL" = tail number assigned to this aircraft
 - "FLT ID" = same as tail number
 - "DF17 DETECTED" = YES (IF ADS-B OUT IS INSTALLED) / NO (IF ADS-B OUT IS NOT INSTALLED)
 - "AA" = ICAO code assigned to this aircraft/tail number (8 digit number in parenthesis)
 - "FS" = IN-AIR
 - "VS" = IN-AIR
- (11) On MFD, press SYS along bottom of MFD. Use the small lower knob on the MFD to scroll to the SETUP page. On the SETUP page, press the SETTINGS softkey to bring up the SETTINGS page. At the bottom of the SETTINGS page, verify:
- (a) The "REGISTRATION NO" number (alphanumeric) matches the "TAIL" number (alphanumeric) displayed on the IFR 6000 (above).

- (12) The “ICAO 24-BIT (OCT)” number matches the “AA” ICAO 24-bit code displayed on the IFR 6000 (above).

NOTE: If the aircraft’s registration number and/or ICAO 24-bit (octal) number are not present on the MFD’s SETTINGS page, the Aircraft Configuration File must be updated, refer to [AMM-31-40-00-051-801 – Aircraft Computer Systems - Maintenance Practices](#).

- (13) On the MFD, scroll to the SETUP tab, press the SENSOR Soft Key. Set the ADC PFD source selection from AUTO to ADC 2.
- (14) On the IFR 6000, press the XPDR button once.
- (15) Once XPDR – ALT ENCODER is displayed, press the SOURCE SELECT Soft Key until SOURCE - XPDR is displayed. Press the RUN TEST Soft Key.
- (16) Make sure that an altitude reported on IFR 6000 matches L PFD altitude indication +/- 100 ft.
- (17) On the MFD, set the ADC source back to AUTO.
- (18) Set the WOW Box Switches to W-on-W (on-ground).
- (19) Set XPDR 2 to STANDBY MODE.

6. **Diversity Transponder–1 Adjustment/Tests**

SUBTASK AMM-34-50-20-071-C-701-003

A. Begin adjustment/test as follows:

- (1) Install Antenna Clamp and Shield Assembly (part of Transponder Test Set IFR 6000) on lower transponder antenna (bottom of the center cabin/fuselage), in accordance with instructions in IFR 6000 Ramp Test Set Operation Manual.
- (a) Position Antenna Clamp inside the slot in the Antenna Shield Plate, aligning captive screws into the respective screw holes.
- (b) Tighten captive screws.
- (c) Cover the transponder's Antenna with Antenna Shield. Loosen thumbscrews if necessary.
- NOTE:** It may be necessary to remove the unit under test's Antenna Guard if access to the transponders Antenna is restricted.
- (d) Secure Antenna Shield by tightening thumbscrews.
- (2) Perform job setup, refer to [SUBTASK AMM-34-50-20-071-C-921-001](#).
- (3) Push ECB BY SYSTEM soft key. Scroll to FLCs using outer knob. Push inner knob to select. Scroll to the listed ECB using outer knob and highlight. Push “COLLAR” soft key. Push “CONFIRM COLLAR” soft key.
- ECB - NOSE LDG GEAR (L AFT Bus)
 - ECB - L MAIN LDG GEAR (L AFT Bus)

- ECB - R MAIN LDG GEAR (L AFT Bus)
- (4) Scroll to ENGINE using outer knob. Push inner knob to select. Scroll to the listed ECB using outer knob and highlight. Push “COLLAR” soft key. Push “CONFIRM COLLAR” soft key.
- ECB - L ENG FIRE EXTNGR (L FWD Bus)
 - ECB - R ENG FIRE EXTNGR (R FWD Bus)
- (5) Clear any “MASTER CAUTIONS” and “MASTER WARNINGS” as needed.
- (6) Set both left and right PFD baro set to 29.92 (in/Hg.) on Autopilot Control Panel (ACP) by pushing BARO SET knob.
- Make sure Baro Set on PFD annunciates “29.92 IN”.
- B. Diversity Transponder-1 Setup
- (1) Use the small rotary knob on the left PFD to select XPDR page.
- NOTE: The XPDR select page times out and switches back to the COM page after 30 seconds. Select XPDR page from time to time during this test.
- (2) Push ACTIVE soft key (upper right button) on the left PFD to select D-XPDR1.
- (3) Make sure that the selected transponder is in Standby Mode.
- (4) Push CODE soft key on left PFD and enter the transponder code used for this test or 1200.
- C. Diversity Transponder-1 MODE A,C,S Test using Transponder Test Set, IFR6000 (Upper Antenna)
- (1) Power up the Transponder Test Set (IFR 6000). After tester performs Self Test, push SETUP button on the test set to bring up the SETUP-XPDR page. If necessary, continue pressing SETUP button until tester cycles to SETUP-XPDR page.
- (2) On the Transponder Test Set (IFR 6000)’s SETUP-XPDR page, use NEXT PARAM or PREV PARAM soft keys to select each parameter, and the “arrow” DATA keys to set the values listed below.
- ANTENNA: TOP
 - RF PORT: ANTENNA
 - ANT RANGE-TOP: 18 ft.
 - ANT HEIGHT-TOP: 7 ft.
 - ANT RANGE-BOTTOM: 18 ft.
 - ANT HEIGHT-BOTTOM: 1 ft.
 - DIR CABLE LOSS: Ignore
 - ANT CABLE: 1 ft.
 - ANT CABLE LOSS: As marked on blue cable (should be 0.1 dB)

- ANT GAIN (dBi) - 1.03 GHz: As marked on test set antenna
 - ANT GAIN (dBi) - 1.09 GHz: As marked on test set antenna
 - UUT ADDRESS: AUTO
 - MANUAL AA: Ignore
 - DIVERSITY TEST: ON
 - PWR LIM: FAR 43
 - CHECK CAP: YES
- (3) Push XPDR button to go to the XPDR-AUTO TEST page.
 - (4) Push CONFIG soft key to display the XPDR-CONFIG SCREEN page.
 - (5) On the XPDR-CONFIG SCREEN, scroll to GENERIC MODE S using the UP/Down DATA keys.
 - (6) With GENERIC MODE S highlighted, push RETURN soft key to confirm selection. This will also cause a return to the XPDR-AUTO TEST page.
 - (7) Set the WOW Box Switches to W-off-W (airborne).
 - (8) Push RUN TEST soft key to start AUTO TEST. The tester will sequence through separate tests, after which a “PASS” message should be displayed.
 - (9) Top ERP should be between 48 to 60 dBm and MTL should be between -68 to -80 dBm to PASS.

NOTE: If values are obtained and any of the individual tests FAIL during AUTO TEST, press TEST LIST button on IFR 6000 and using UP/DOWN buttons scroll to the specific Failed test(s). Press SELECT TEST button, adjust IFR 6000 test set positioning anywhere within a 30 foot arc between the aircraft’s right wingtip and the nose as required, and Press RUN TEST button until PASS Message is received (this may take several test set position adjustments until IFR 6000 and aircraft Transponder “Sync up”). Press STOP TEST button. Repeat until all individual FAILED tests have achieved a PASS. It is not necessary to re-run AUTO TEST. AUTO TEST is a convenience feature only.

NOTE: If POWER/FREQ test Fails: After pressing RUN TEST, adjust IFR-6000 test set positioning while test is running until PASS message appears (this test performs a “Live” update of the dBm values). It may be required to position the test set anywhere within a 30 foot arc between the aircraft’s right wingtip and the nose. Press the STOP TEST button as soon as PASS message is displayed

- (10) Make sure the following appears on the Transponder Test Set (IFR 6000):
 - “A CODE” = transponder code entered
 - “C ALT” = left PFD altitude indication +/- 100 ft.
 - “S CODE” = ICAO code assigned to this aircraft/tail number

- “TAIL” = tail number assigned to this aircraft
 - “FLT ID” = same as tail number
 - DF17 DETECTED” = YES (IF ADS-B OUT IS INSTALLED) / NO (IF ADS-B OUT IS NOT INSTALLED)
 - “AA” = ICAO code assigned to this aircraft/tail number (8 digit number in parenthesis)
 - “FS” = IN-AIR
 - “VS” = IN-AIR
- (11) On MFD, press SYS along bottom of MFD. Use the small lower knob on the MFD to scroll to the SETUP page. On the SETUP page, press the SETTINGS soft key to bring up the SETTINGS page. At the bottom of the SETTINGS page, verify:
- (a) The “REGISTRATION NO” number (alphanumeric) matches the “TAIL” number (alphanumeric) displayed on the IFR 6000 (above).
 - (b) The “ICAO 24-BIT (OCT)” number matches the “AA” ICAO 24-bit code displayed on the IFR 6000 (above).
- NOTE: If the aircraft’s registration number and/or ICAO 24-bit (octal) number are not present on the MFD’s SETTINGS page, the Aircraft Configuration File must be updated, refer to [AMM-31-40-00-051-801 – Aircraft Computer Systems - Maintenance Practices](#). Steps (10) through this step must then be repeated.
- (12) On the MFD, scroll to the SETUP tab, press the SENSOR Soft Key. Set the ADC PFD source selection from AUTO to ADC 2.
- (13) On the IFR 6000, press the XPDR button once.
- (14) Once XPDR – ALT ENCODER is displayed, press the SOURCE SELECT Soft Key until SOURCE - XPDR is displayed. Press the RUN TEST Soft Key.
- (15) Make sure that an altitude reported on IFR 6000 matches L PFD altitude indication +/- 100 ft.
- (16) On the MFD, set the ADC source back to AUTO.
- (17) Set the WOW Box Switches to W-on-W (on-ground).
- (18) Set D-XPDR 1 to STANDBY MODE.
- D. Diversity Transponder-1 MODE A,C,S Test using Transponder Test Set (IFR 6000) (Lower Antenna)
- (1) Remove Antenna Clamp and Shield Assembly (part of Transponder Test Set IFR 6000) from lower transponder antenna (bottom center cabin/fuselage).
 - (2) Install Antenna Clamp and Shield Assembly (part of Transponder Test Set IFR 6000) on upper transponder antenna (top of the center cabin/fuselage), in accordance with instructions in IFR 6000 Ramp Test Set Operation Manual.

- (3) Pre-position the Transponder Test Set IFR 6000 antenna to point at the aircraft's lower Transponder 2 antenna, (bottom of the center cabin/fuselage).
- (4) Push XPDR button to go to the XPDR-AUTO TEST page.
- (5) Push CONFIG soft key to display the XPDR-CONFIG SCREEN page.
- (6) On the XPDR-CONFIG SCREEN, scroll to GENERIC MODE S using the UP/Down DATA keys.
- (7) With GENERIC MODE S highlighted, push RETURN soft key to confirm selection. This will also cause a return to the XPDR-AUTO TEST page.
- (8) Set the WOW Box Switches to W-off-W (airborne).
- (9) Push RUN TEST soft key to start AUTO TEST. The tester will sequence through separate tests, after which a "PASS" message should be displayed.
- (10) ERP should be between 48 to 60 dBm and MTL should be between -68 to -80 dBm to PASS.

NOTE: If values are obtained and any of the individual tests FAIL during AUTO TEST, press TEST LIST button on IFR 6000 and using UP/DOWN buttons scroll to the specific Failed test(s). Press SELECT TEST button, adjust IFR 6000 test set positioning anywhere within a 30 foot arc between the aircraft's right wingtip and the nose as required, and Press RUN TEST button until PASS Message is received (this may take several test set position adjustments until IFR 6000 and aircraft Transponder "Sync up"). Press STOP TEST button. Repeat until all individual FAILED tests have achieved a PASS. It is not necessary to re-run AUTO TEST. AUTO TEST is a convenience feature only.

NOTE: If POWER/FREQ test Fails: After pressing RUN TEST, adjust IFR-6000 test set positioning while test is running until PASS message appears (this test performs a "Live" update of the dBm values). It may be required to position the test set anywhere within a 30 foot arc between the aircraft's right wingtip and the nose. Press the STOP TEST button as soon as PASS message is displayed

- (11) Remove Antenna Clamp and Shield Assembly.
- (12) Set the WOW Box Switches to W-on-W (on-ground).

7. Diversity Transponder-2 Adjustment/Tests

SUBTASK AMM-34-50-20-071-C-701-004

A. Begin adjustment/test as follows:

- (1) Install Antenna Clamp and Shield Assembly (part of Transponder Test Set IFR 6000) on lower transponder antenna (bottom of the center cabin/fuselage), in accordance with instructions in IFR 6000 Ramp Test Set Operation Manual.
 - (a) Position Antenna Clamp inside the slot in the Antenna Shield Plate, aligning captive screws into the respective screw holes.

- (b) Tighten captive screws.
- (c) Cover the transponder's Antenna with Antenna Shield. Loosen thumbscrews if necessary.

NOTE: It may be necessary to remove the unit under test's Antenna Guard if access to the transponders Antenna is restricted.

- (d) Secure Antenna Shield by tightening thumbscrews.
- (2) Perform job setup, refer to [SUBTASK AMM-34-50-20-071-C-921-001](#).
- (3) Push ECB BY SYSTEM soft key. Scroll to FLCS using outer knob. Push inner knob to select. Scroll to the listed ECB using outer knob and highlight. Push "COLLAR" soft key. Push "CONFIRM COLLAR" soft key.
 - ECB - NOSE LDG GEAR (L AFT Bus)
 - ECB - L MAIN LDG GEAR (L AFT Bus)
 - ECB - R MAIN LDG GEAR (L AFT Bus)
- (4) Scroll to ENGINE using outer knob. Push inner knob to select. Scroll to the listed ECB using outer knob and highlight. Push "COLLAR" soft key. Push "CONFIRM COLLAR" soft key.
 - ECB - L ENG FIRE EXTNGR (L FWD Bus)
 - ECB - R ENG FIRE EXTNGR (R FWD Bus)
- (5) Clear any "MASTER CAUTIONS" and "MASTER WARNINGS" as needed.
- (6) Set both left and right PFD baro set to 29.92 (in/Hg.) on Autopilot Control Panel (ACP) by pushing BARO SET knob.
 - Make sure Baro Set on PFD annunciates "29.92 IN".

B. Diversity Transponder-2 Setup

- (1) Use the small rotary knob on the left PFD to select XPDR page.

NOTE: The XPDR select page times out and switches back to the COM page after 30 seconds. Select XPDR page from time to time during this test.
- (2) Push ACTIVE soft key (upper right button) on the left PFD to select D-XPDR2.
- (3) Make sure that D-XPDR2 is in Standby Mode.
- (4) Push CODE soft key on left PFD and enter the transponder code used for this test or 1200.

C. Diversity Transponder-2 MODE A,C,S Test using Transponder Test Set, IFR6000 (Upper Antenna)

- (1) Power up the Transponder Test Set (IFR 6000). After tester performs Self Test, push SETUP button on the test set to bring up the SETUP-XPDR page. If necessary, continue pressing SETUP button until tester cycles to SETUP-XPDR page.

- (2) On the Transponder Test Set (IFR 6000)'s SETUP-XPDR page, use NEXT PARAM or PREV PARAM soft keys to select each parameter, and the "arrow" DATA keys to set the values listed below.
 - ANTENNA: TOP
 - RF PORT: ANTENNA
 - ANT RANGE-TOP: 18 ft.
 - ANT HEIGHT-TOP: 7 ft.
 - ANT RANGE-BOTTOM: 18 ft.
 - ANT HEIGHT-BOTTOM: 1 ft.
 - DIR CABLE LOSS: Ignore
 - ANT CABLE: 1 ft.
 - ANT CABLE LOSS: As marked on blue cable (should be 0.1 dB)
 - ANT GAIN (dBi) - 1.03 GHz: As marked on test set antenna
 - ANT GAIN (dBi) - 1.09 GHz: As marked on test set antenna
 - UUT ADDRESS: AUTO
 - MANUAL AA: Ignore
 - DIVERSITY TEST: ON
 - PWR LIM: FAR 43
 - CHECK CAP: YES
- (3) Push XPDR button to go to the XPDR-AUTO TEST page.
- (4) Push CONFIG soft key to display the XPDR-CONFIG SCREEN page.
- (5) On the XPDR-CONFIG SCREEN, scroll to GENERIC MODE S using the UP/Down DATA keys.
- (6) With GENERIC MODE S highlighted, push RETURN soft key to confirm selection. This will also cause a return to the XPDR-AUTO TEST page.
- (7) Set the WOW Box Switches to W-off-W (airborne).
- (8) Push RUN TEST soft key to start AUTO TEST. The tester will sequence through separate tests, after which a "PASS" message should be displayed.

- (9) Top ERP should be between 48 to 60 dBm and MTL should be between -68 to -80 dBm to PASS.

NOTE: If values are obtained and any of the individual tests FAIL during AUTO TEST, press TEST LIST button on IFR 6000 and using UP/DOWN buttons scroll to the specific Failed test(s). Press SELECT TEST button, adjust IFR 6000 test set positioning anywhere within a 30 foot arc between the aircraft's right wingtip and the nose as required, and Press RUN TEST button until PASS Message is received (this may take several test set position adjustments until IFR 6000 and aircraft Transponder "Sync up"). Press STOP TEST button. Repeat until all individual FAILED tests have achieved a PASS. It is not necessary to re-run AUTO TEST. AUTO TEST is a convenience feature only.

NOTE: If POWER/FREQ test Fails: After pressing RUN TEST, adjust IFR-6000 test set positioning while test is running until PASS message appears (this test performs a "Live" update of the dBm values). It may be required to position the test set anywhere within a 30 foot arc between the aircraft's right wingtip and the nose. Press the STOP TEST button as soon as PASS message is displayed

- (10) Make sure the following appears on the Transponder Test Set (IFR 6000):
- "A CODE" = transponder code entered
 - "C ALT" = left PFD altitude indication +/- 100 ft.
 - "S CODE" = ICAO code assigned to this aircraft/tail number
 - "TAIL" = tail number assigned to this aircraft
 - "DF17 DETECTED" = YES (IF ADS-B OUT IS INSTALLED) / NO (IF ADS-B OUT IS NOT INSTALLED)
 - "FLT ID" = same as tail number
 - "AA" = ICAO code assigned to this aircraft/tail number (8 digit number in parenthesis)
 - "FS" = IN-AIR
 - "VS" = IN-AIR
- (11) On MFD, press SYS along bottom of MFD. Use the small lower knob on the MFD to scroll to the SETUP page. On the SETUP page, press the SETTINGS softkey to bring up the SETTINGS page. At the bottom of the SETTINGS page, verify:
- (a) The "REGISTRATION NO" number (alphanumeric) matches the "TAIL" number (alphanumeric) displayed on the IFR 6000 (above).

- (b) The “ICAO 24-BIT (OCT)” number matches the “AA” ICAO 24-bit code displayed on the IFR 6000 (above).

NOTE: If the aircraft’s registration number and/or ICAO 24-bit (octal) number are not present on the MFD’s SETTINGS page, the Aircraft Configuration File must be updated, refer to [AMM-31-40-00-051-801 – Aircraft Computer Systems - Maintenance Practices](#). Steps (10) through this step must then be repeated.

- (12) On the MFD, scroll to the SETUP tab, press the SENSOR Soft Key. Set the ADC PFD source selection from AUTO to ADC 2.
- (13) On the IFR 6000, press the XPDR button once.
- (14) Once XPDR – ALT ENCODER is displayed, press the SOURCE SELECT Soft Key until SOURCE - XPDR is displayed. Press the RUN TEST Soft Key.
- (15) Make sure that an altitude reported on IFR 6000 matches L PFD altitude indication +/- 100 ft.
- (16) On the MFD, set the ADC source back to AUTO.
- (17) Set the WOW Box Switches to W-on-W (on-ground).
- (18) Set D-XPDR 2 to STANDBY MODE.
- D. Diversity Transponder-2 MODE A,C,S Test using Transponder Test Set (IFR 6000) (Lower Antenna)
- (1) Remove Antenna Clamp and Shield Assembly (part of Transponder Test Set IFR 6000) from lower transponder antenna (bottom of the center cabin/fuselage).
- (2) Install Antenna Clamp and Shield Assembly (part of Transponder Test Set IFR 6000) on upper transponder antenna (top of the center cabin/fuselage), in accordance with instructions in IFR 6000 Ramp Test Set Operation Manual.
- (3) Pre-position the Transponder Test Set IFR 6000 antenna to point at the aircraft’s lower Transponder 2 antenna (bottom of the center cabin/fuselage).
- (4) On the Transponder Test Set (IFR 6000) SETUP-XPDR page, use NEXT PARAM or PREV PARAM softkeys to select each parameter, and the “arrow” DATA keys to set the values listed below:
- ANTENNA: BOTTOM
 - RF PORT: ANTENNA
 - ANT RANGE-TOP: 18 ft.
 - ANT HEIGHT-TOP: 7 ft.
 - ANT RANGE-BOTTOM: 18 ft.
 - ANT HEIGHT-BOTTOM: 1 ft.
 - DIR CABLE LOSS: Ignore
 - ANT CABLE: 1 ft.
 - ANT CABLE LOSS: As marked on blue cable (should be 0.1 dB)

- ANT GAIN (dBi) - 1.03 GHz: As marked on test set antenna
 - ANT GAIN (dBi) - 1.09 GHz: As marked on test set antenna
 - UUT ADDRESS: AUTO
 - MANUAL AA: Ignore
 - DIVERSITY TEST: ON
 - PWR LIM: FAR 43
 - CHECK CAP: YES
- (5) Push XPDR button to go to the XPDR-AUTO TEST page.
 - (6) Push CONFIG soft key to display the XPDR-CONFIG SCREEN page.
 - (7) On the XPDR-CONFIG SCREEN, scroll to GENERIC MODE S using the UP/Down DATA keys.
 - (8) With GENERIC MODE S highlighted, push RETURN soft key to confirm selection. This will also cause a return to the XPDR-AUTO TEST page.
 - (9) Set the WOW Box Switches to W-off-W (airborne).
 - (10) Push RUN TEST soft key to start AUTO TEST. The tester will sequence through separate tests, after which a “PASS” message should be displayed.
 - (11) Bottom ERP should be between 48 to 60 dBm and MTL should be between -68 to -80 dBm to PASS.

NOTE: If values are obtained and any of the individual tests FAIL during AUTO TEST, press TEST LIST button on IFR 6000 and using UP/DOWN buttons scroll to the specific Failed test(s). Press SELECT TEST button, adjust IFR 6000 test set positioning anywhere within a 30 foot arc between the aircraft’s right wingtip and the nose as required, and Press RUN TEST button until PASS Message is received (this may take several test set position adjustments until IFR 6000 and aircraft Transponder “Sync up”). Press STOP TEST button. Repeat until all individual FAILED tests have achieved a PASS. It is not necessary to re-run AUTO TEST. AUTO TEST is a convenience feature only.

NOTE: If POWER/FREQ test Fails: After pressing RUN TEST, adjust IFR-6000 test set positioning while test is running until PASS message appears (this test performs a “Live” update of the dBm values). It may be required to position the test set anywhere within a 30 foot arc between the aircraft’s right wingtip and the nose. Press the STOP TEST button as soon as PASS message is displayed

- (12) Remove Antenna Clamp and Shield Assembly from aircraft and stow in IFR 6000 ramp test set kit.
- (13) Remove Antenna Clamp and Shield Assembly and stow in ramp test kit.
- (14) Set the WOW Box Switches to W-on-W (on-ground).

8. Job Close-Up

SUBTASK AMM-34-50-20-071-C-921-005

- A. Set WOW Box switches to W-on-W (on-ground)
- B. Reset the collared ECB's. Refer to AMM-20-00-03-051-801 – Prepare Anti-Ice Systems For Maintenance.
- C. Scroll to FLCs using outer knob. Press inner knob to select. Scroll to the listed ECB using outer knob and highlight. Push “RESET” Soft key. Press “CONFIRM RESET” soft key.
 - ECB - NOSE LDG GEAR (L AFT Bus)
 - ECB - L MAIN LDG GEAR (L AFT Bus)
 - ECB - R MAIN LDG GEAR (L AFT Bus)
- D. Scroll to ENGINE using outer knob. Press inner knob to select. Scroll to the listed ECB using outer knob and highlight. Push “RESET” Soft key. Press “CONFIRM RESET” soft key.
 - ECB - L ENG FIRE EXTNGR (L FWD Bus)
 - ECB - R ENG FIRE EXTNGR (R FWD Bus)
- E. Power down the aircraft by setting the SYS BATT and START BATT switches to OFF and the BUS TIE to OPEN.
- F. Disconnect WOW Box from aircraft. Refer to AMM-20-00-04-051-801 – Weight On Wheels (WOW) Box - Connect/Disconnect.
- G. If on jacks, lower aircraft and remove jacks. Refer to [AMM-07-10-00-051-801 – Jacking - Maintenance Practices](#).
- H. If applicable, call the local control tower and tell them the transponder test is complete.
- I. Remove all tools, equipment and unwanted material from work area.
- J. Disconnect external power. Refer to [AMM-24-40-00-051-801 – External Power - Maintenance Practices](#).
- K. If all other maintenance is complete, return aircraft to service. Refer to [AMM-20-00-02-051-801 – Return To Service \(After Maintenance\)](#).

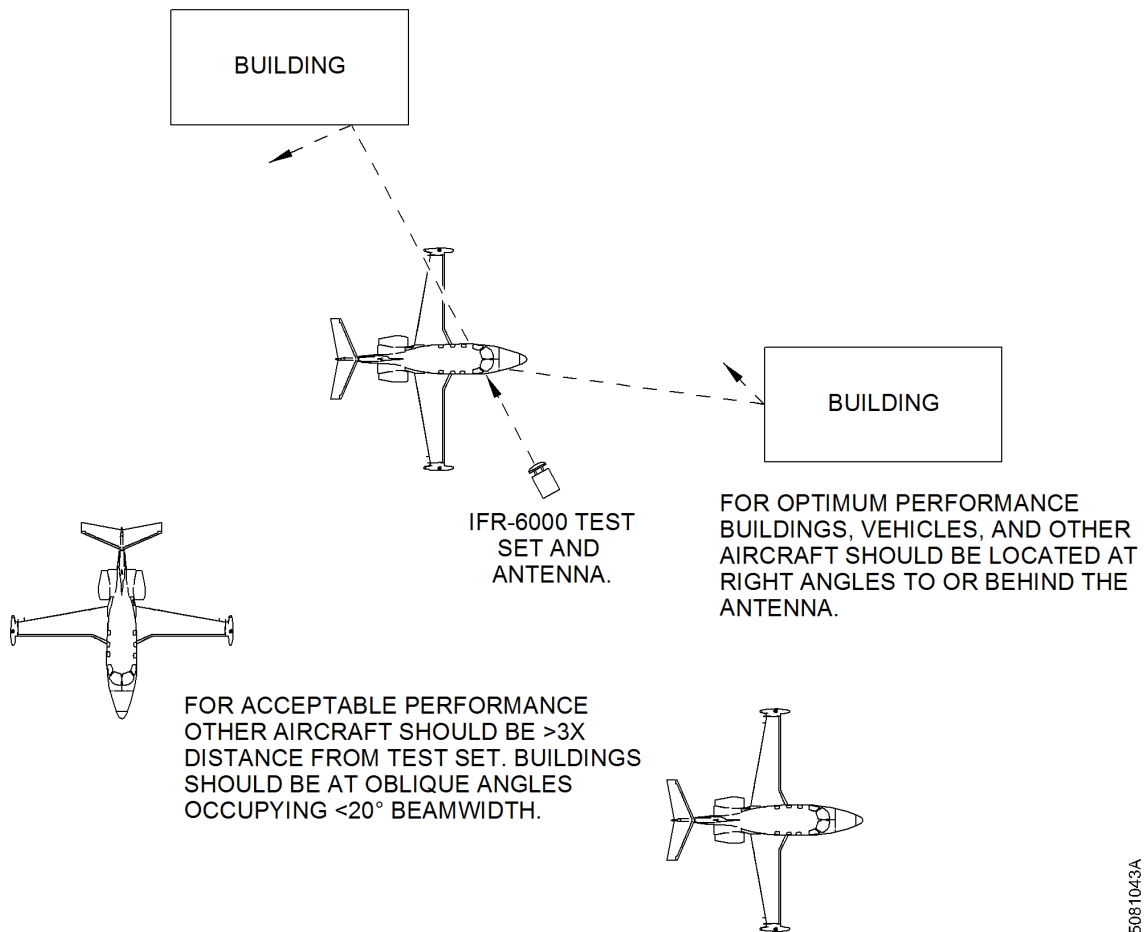
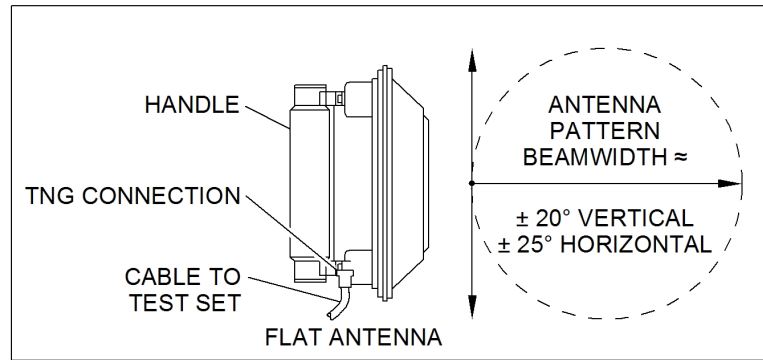

5081043A

**Transponder - Adjustment/Test
Figure 501 (Sheet 1 of 1)**

ADS-B - ADJUSTMENT/TEST

AMM-34-50-21-071-801

1. General

- A. This task gives procedures to do the adjustment/test of the ADS-B.

NOTE: ADS-B test is only required, if the ADS-B function is enabled.

2. Equipment and Materials

- A. Special Tools and Equipment

Name and Part Number
Transponder Test Set (Aeroflex, IFR6000) or equivalent
Weight-on-Wheels (WOW) Box (EAI, 87-117390-1001) or AMC 2.4.01 (or higher).
Ground Power Unit (GPU). AllStar 450 or AllStar G.S.E. or Hobart GPU-400 or Hobart GPU-600 or Bycan PS-28100

3. Job Set-Up

SUBTASK AMM-34-50-21-071-921-001

- A. Make aircraft safe for maintenance. Refer to [AMM-20-00-01-051-801 – Make Safe For Maintenance](#).
- B. If on jacks, refer to [AMM-07-10-00-051-801 – Jacking - Maintenance Practices](#) and [AMM-08-20-00-051-801 – Leveling](#).
- C. Connect external power. Refer to [AMM-24-40-00-051-801 – External Power - Maintenance Practices](#). Do not turn on START BATT and SYS BATT switches until prompted.
- D. Prepare Anti-ice system for maintenance. Refer to [AMM-20-00-03-051-801 – Prepare Anti-Ice Systems For Maintenance](#) .
- E. Take proper safety precautions to protect personnel. Position aircraft such that multi-path RF reflections between the IFR-6000 test set, the aircraft’s antennas, and surrounding objects are minimized. The area on the left side of the aircraft should not be up against a metal wall or another aircraft. If necessary, position the aircraft outside, away from metal buildings or other aircraft. Refer to .

CAUTION: FAILURE TO COMPLY WITH THIS STEP AND CONTINUING WITH THIS PROCEDURE COULD IMPACT LOCAL AIRPORT TOWER OPERATIONS.

- F. If applicable, contact local airport tower to inform them a transponder test is being run at your location (inside or outside). Request appropriate squawk and allotted time to run test.

NOTE: If local airport tower is not informed, use code 1200.

- G. Attach test set antenna to Transponder Test Set using 1 foot long test set cable (blue cable, supplied if IFR6000 is used), connected to ANT port on tester.
- H. During testing, place the Transponder Test Set antenna approximately two feet to four feet forward and in line with right wing tip tank. May require periodic repositioning between two and four feet.
- I. Connect Weight On Wheels (WOW) box or Aircraft Maintenance Computer (AMC) and set switches on Box to W-On-W (on-ground). Refer to [AMM-20-00-04-051-801 – Weight On Wheels \(WOW\) Box - Connect/Disconnect](#).

4. **ADS-B System Test**

SUBTASK AMM-34-50-21-071-701-002

- A. In order to verify ADS-B OUT function is active, perform the following test using IFR 6000 or an equivalent test set.

NOTE: If IFR 6000 (or an equivalent transponder test set) does not include the ADS-B test capability, at a minimum, verification that the DF17 extended squitter format is being detected is sufficient. During Generic Mode S tests, DF17 format availability is being checked in the following subtasks:

- [SUBTASK AMM-34-50-20-071-C-701-001](#)
- [SUBTASK AMM-34-50-20-071-C-701-002](#)
- [SUBTASK AMM-34-50-20-071-C-701-003](#)
- [SUBTASK AMM-34-50-20-071-C-701-004](#)

NOTE: If no transponder test set with the ADS-B test capability is available, as an additional or alternate method of verifying proper operation and performance of the installed ADS-B OUT function, the FAA Public ADS-B Performance Report (PAPR) may be requested after a Return to Service (RTS) flight. This report request may be made online on the FAA web site at the ADS-B related area.

NOTE: To check if IFR 6000 has the ADS-B test, press SETUP to display SETUP-GENERAL page. Press INFO and verify that ADSB is listed in the OPTIONS area.

If using IFR 6000 with the ADSB test option, to make sure that the ADS-B OUT function is active, perform the following procedure:

- (1) ADS-B Test Setup

- (a) After the Transponder Test Set (IFR 6000) performs Self Test, push SETUP button on the test set to bring up the SETUP-XPDR page. If necessary, continue pressing SETUP button until SETUP XPDR screen is displayed.
- (b) Press ADS-B SETUP Soft Key to display the SETUP-ADSB Setup Screen. Use NEXT PARAM and PREV PARAM Soft Keys to select each parameter. Configure the setup parameters as shown in the following example:
POS DECODE: GLOBAL
LAT: 35 02 13.80 N
LON: 106 37 1.80 W
BARO PRES ALT: 5450 ft.
ADSB MON: DF17

NOTE: LAT and LON must be set to the values corresponding to the location of the test as shown on the MFD GPS Status Page. In this example, for the test set entry, the position data corresponds to the MFD displayed position data of N35°02.23' W106°37.03', where seconds are represented as a fraction of a minute, and, therefore, the entered seconds' values are $0.23 \times 60 \text{ sec} = 13.80 \text{ sec}$ and $0.03 \times 60 \text{ sec} = 1.80 \text{ sec}$, respectively. BARO PRES ALT is a test reference and must be set to the value corresponding to the tested aircraft Pressure Altitude. Therefore, using the Autopilot Control Panel (ACP) controls, set Baro Correction to 29.92 inHg, and then enter the altitude value displayed on the PFD into BARO PRES ALT entry field of IFR 6000. This entry may not be available in some IFR 6000 test sets.

(2) ADS-B OUT Data Monitor Test

- (a) Make sure aircraft power is off.
- (b) Set WOW Box switches to W-on-W (on-ground).
- (c) On IFR 6000, press XPDR mode Key until ADSB/GICB/UAT MAIN menu is displayed. Press the ADS-B MON Soft Key to display the ADS-B MON list screen.
- (d) Power up the aircraft.
- (e) On the PFD, select active transponder and enter transponder test squawk code as 1200 (or as assigned by the Air Traffic Control).
- (f) Make sure that the Baro Correction is set to 29.92 inHg.
- (g) Set WOW Box switches to W-off-W (airborne). Transponder should be in ALT mode.
- (h) Select BDS 0,5 AIRBORNE POS and check the following data:
AA = matches aircraft ICAO code displayed on the MFD Settings Page
LAT = comparable to the aircraft latitude.
LON = comparable to the aircraft longitude.
BARO PRES ALT = matches aircraft altitude displayed on the L PFD within 125 ft.
- (i) Set WOW Box switches to W-on-W (on-ground).

5. Job Close-Up

SUBTASK AMM-34-50-21-071-921-003

- A. Reset the collared ECB's. Refer to AMM-20-00-03-051-801 – Prepare Anti-Ice Systems For Maintenance.
- B. Scroll to FLCS using outer knob. Press inner knob to select. Scroll to the listed ECB using outer knob and highlight. Push "RESET" Soft key. Press "CONFIRM RESET" soft key.
 - ECB - NOSE LDG GEAR (L AFT Bus)
 - ECB - L MAIN LDG GEAR (L AFT Bus)
 - ECB - R MAIN LDG GEAR (L AFT Bus)
- C. Scroll to ENGINE using outer knob. Press inner knob to select. Scroll to the listed ECB using outer knob and highlight. Push "RESET" Soft key. Press "CONFIRM RESET" soft key.
 - ECB - L ENG FIRE EXTNGR (L FWD Bus)
 - ECB - R ENG FIRE EXTNGR (R FWD Bus)
- D. Power down the aircraft by setting the SYS BATT and START BATT switches to OFF and the BUS TIE to OPEN.
- E. Disconnect WOW Box from aircraft. Refer to AMM-20-00-04-051-801 – Weight On Wheels (WOW) Box - Connect/Disconnect.
- F. If on jacks, lower aircraft and remove jacks. Refer to [AMM-07-10-00-051-801 – Jacking - Maintenance Practices](#).
- G. If applicable, call the local control tower and tell them the transponder test is complete.
- H. Remove all tools, equipment and unwanted material from work area.
- I. Disconnect external power. Refer to [AMM-24-40-00-051-801 – External Power - Maintenance Practices](#).
- J. If all other maintenance is complete, return aircraft to service. Refer to [AMM-20-00-02-051-801 – Return To Service \(After Maintenance\)](#).

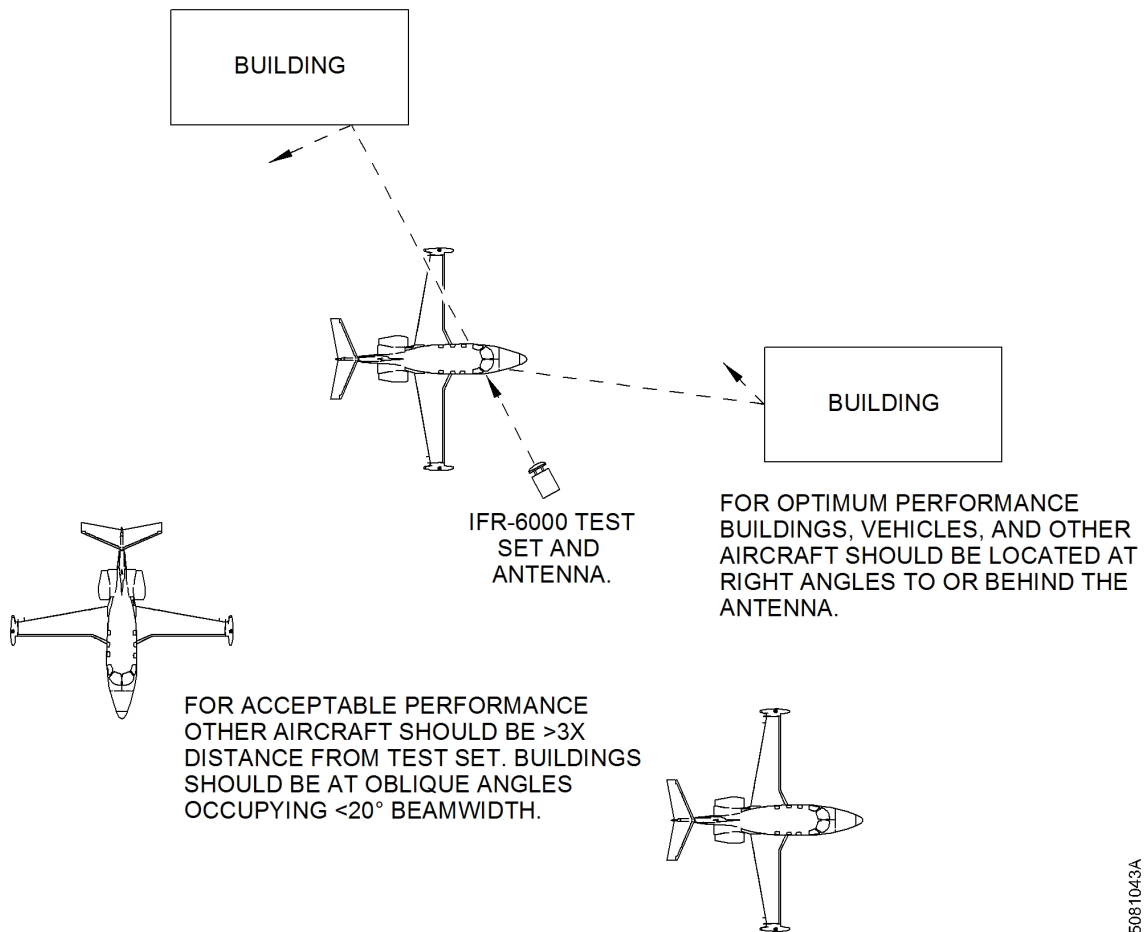
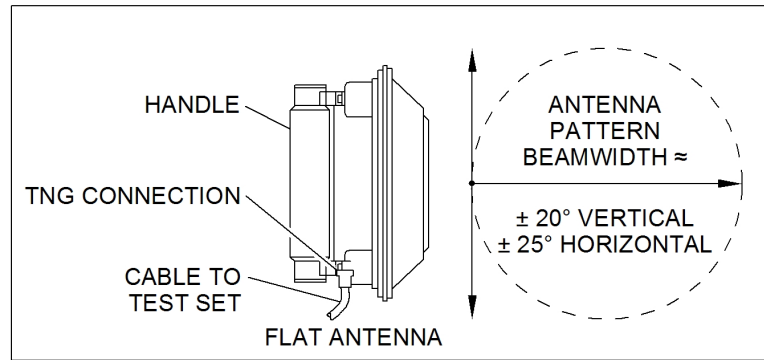

**ADS-B - Adjustment/Test
Figure 501 (Sheet 1 of 1)**

5081043A

THIS PAGE INTENTIONALLY LEFT BLANK

TRANSPONDER ANTENNA RELAY - INSTALLATION

AMM-34-50-23-041-801

1. General

- A. This task gives the procedures to install the transponder antenna relay(s).
 - (1) Single Diversity Transponder Configuration:
 - (a) There is one transponder lower antenna relay installed with the optional Single Diversity Transponder configuration behind the instrument panel.
 - (2) Dual Diversity Transponder Configuration
 - (a) There are two transponder (upper and lower) antenna relays installed with the optional Dual Diversity Transponder configuration behind the instrument panel.

2. Job Set-Up

SUBTASK AMM-34-50-23-041-921-001

- A. Make sure the aircraft is in the same configuration as it was when the removal task was completed. Refer to [AMM-34-50-23-001-801 – Transponder Antenna Relay - Removal](#).

3. Procedure

SUBTASK AMM-34-50-23-041-411-001

(Refer to [Fig. 401](#). Installation procedures apply to both sides)

NOTE: The lower antenna relay (and upper antenna relay if a second diversity transponder is installed) are located inboard of their respective diversity transponder(s).

- A. Remove the protective caps from the electrical connectors.
- B. Put the transponder lower and/or (if installed) upper antenna relay (1) on the structure and align the holes.
- C. Attach the transponder lower and/or (if installed) upper antenna relay (1) with the two screws (3) and washers (2).
- D. Connect the coax cable connectors 23K02P01 to the transponder lower antenna relay coax receptacle marked COM (Common) (5).
- E. If transponder upper antenna relay installed, connect the coax cable connectors 23K03P01 to the transponder upper antenna relay coax receptacle marked COM (Common) (5).
- F. Connect the coax cable connectors 23K02P02 to the transponder lower antenna relay coax receptacle marked NC (Normally Closed) (6).

- G. If transponder upper antenna relay installed, connect the coax cable connectors 23K03P02 to the transponder upper antenna relay coax receptacle marked NC (Normally Closed) (6) .
- H. Connect the coax cable connectors 23K02P03 to the transponder lower antenna relay coax receptacle marked NO (Normally Open) (4) .
- I. If transponder upper antenna relay installed, connect the coax cable connectors 23K03P03 to the transponder upper antenna relay coax receptacle marked NO (Normally Open) (4) .
- J. Connect the electrical connector 23K02P04 to the transponder lower antenna relay electrical receptacle (7) .
- K. If transponder upper antenna relay installed, connect the electrical connector 23K03P04 to the transponder upper antenna relay electrical receptacle (7) .
- L. Electrically bond the transponder lower antenna relay (1) to the structure. Refer to [AMM-20-03-00-051-801 – Electrical Bonding - Maintenance Practices](#). Resistance must be 2.5 milliohms or less.

4. **Job Close-Up**

SUBTASK AMM-34-50-23-041-921-002

- A. Remove all tools, equipment, and unwanted material from the work area.
- B. If removed, install the air conditioning ducts. Refer to [AMM-21-20-11-041-801 – Cockpit Ducting - Installation](#).
- C. Install the 222 KZ - Multi Function Display (MFD). Refer to [AMM-31-10-15-041-801 – Multi-Function Display - Installation](#).
- D. Remove the warning placards.
- E. Do the adjustment/test of the transponder system. Noting effectivity, refer to [AMM-34-50-20-071-801 – Transponder - Adjustment/Test](#)
- F. If all other maintenance is complete, return the aircraft to service. Refer to [AMM-20-00-02-051-801 – Return To Service \(After Maintenance\)](#).

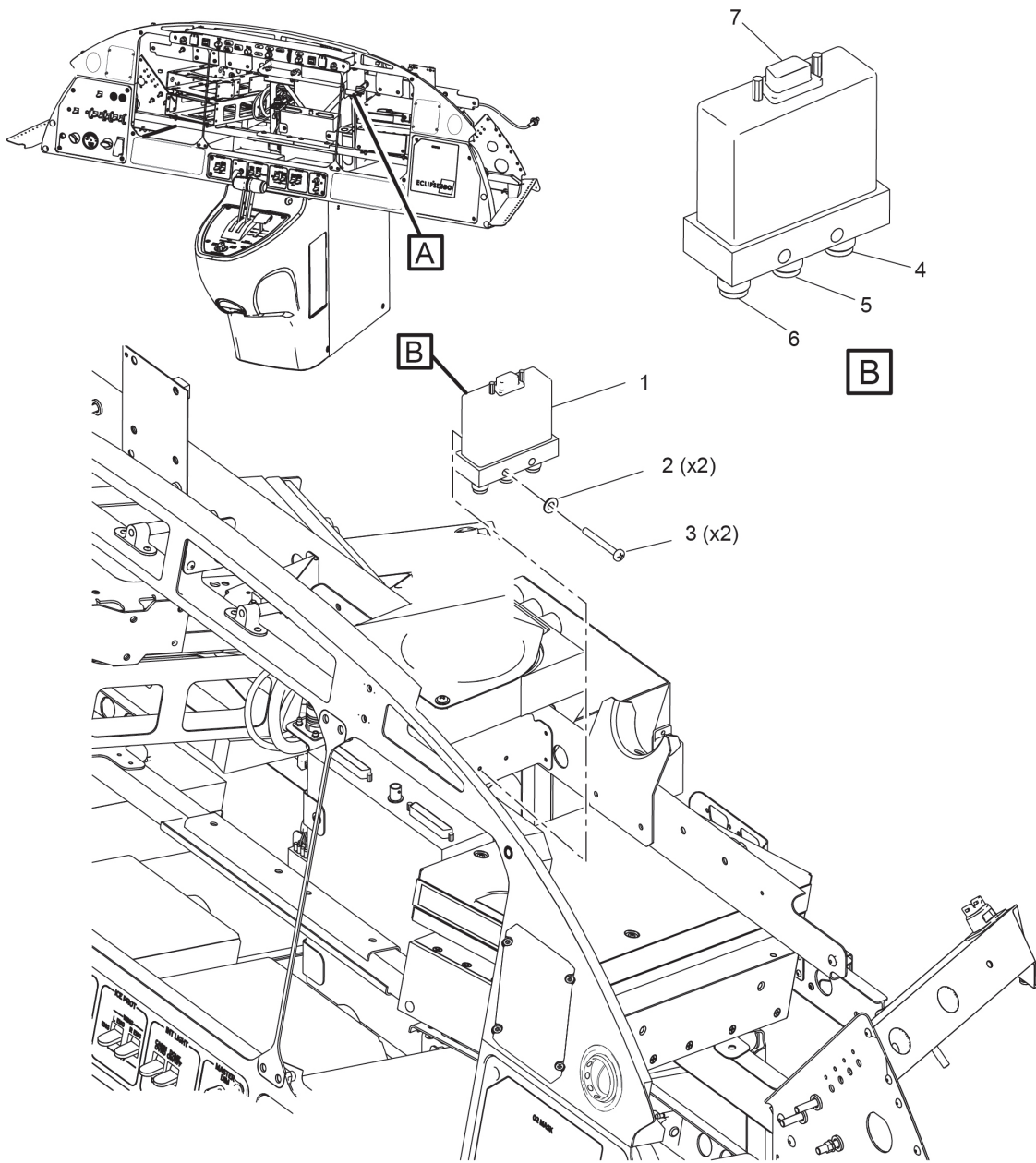

NOTE:
STRUCTURE AND EQUIPMENT
REMOVED FOR CLARITY

A

5080777B

**Transponder Antenna Relay - Removal/Installation (Avio NG +1.5 Display shown)
Figure 401 (Sheet 1 of 1)**

THIS PAGE INTENTIONALLY LEFT BLANK