

## CHAPTER - 34 HIGHLIGHTS (Summary of Changes)

*Revision No. TR34-21 Sep 30/20*

TO: HOLDERS OF THE AIRCRAFT MAINTENANCE MANUAL (06-117751)

Pages that have been added or revised are summarized below. Remove and insert the affected pages as listed, and enter the above revision number with issue date into the Record of Revisions sheet.

**This Temporary Revision incorporates and supersedes previously released temporary revisions for the chapters listed below.**

*Do not remove this page. Keep it in place as a record of previous changes.*

CH/SE/SU Page Block No.	Description of Change
34-10-00 PgBlk 501	Adjustment / Test - Added Standby Pitot/Static Verification with Standby Display Unit (SDU).
34-10-10 PgBlk 401-Rem (C)	Added MB 500-34-028 to effectivity for Pitot/AOA Probe auxiliary heaters - Removal - Config C.
34-10-10 PgBlk 401-Inst (C)	Added MB 500-34-028 to effectivity for Pitot/AOA Probe auxiliary heaters - Installation - Config C.
34-40-50 PgBlk 1 (A)	Description and Operation – Config A. Corrected effectivity.
34-40-50 PgBlk 1 (B)	Description and Operation – Config B. Added configuration B – POST SB 500-31-024.
34-40-50 PgBlk 501 (A)	Adjustment/Test – Config A. Corrected effectivity.
34-40-50 PgBlk 501 (B)	Adjustment/Test – Config B. Added configuration for Stormscope lightning strike test post SB 500-31-024.
34-50-10 PgBlk 1 (B)	Description and Operation - Revised Effectivity (ALL POST MB 500-31-018). Revised Description.
34-50-10 PgBlk 201 (A)	Description and Operation - Revised Effectivity (ALL POST MB 500-31-018). Updated for ADS-B Out – Config A.
34-50-10 PgBlk 201 (B)	Added GPS 3 (GDL 88) Maintenance Practices – Config B.
34-50-10 PgBlk 501 (C)	Adjustment/Test for GPS Units – Config C.
34-50-11 PgBlk 401-Rem (C)	Added GPS 3 (GDL 88) Unit Removal procedure.

<b>CH/SE/SU Page Block No.</b>	<b>Description of Change</b>
34-50-11 PgBlk 401-Rem (D)	Added Removal procedure for iFMS 2.7 GPS.
34-50-11 PgBlk 401-Inst (B)	GPS Installation - Revised Effectivity (ALL POST MB 500-31-018) and Job Close-Up.
34-50-11 PgBlk 401-Inst (C)	Added GPS 3 Unit Installation procedure.
34-50-11 PgBlk 401-Inst (D)	Added Installation procedure for iFMS 2.7 GPS.
34-50-13 PgBlk 401-Rem	Added GPS 3 Mount Removal procedure.
34-50-13 PgBlk 401-Inst	Added GPS 3 Mount Installation procedure.
34-50-14 PgBlk 401-Rem	Added GPS 2 Antenna Splitter Removal procedure.
34-50-14 PgBlk 401-Inst	Added GPS 2 Antenna Splitter Installation procedure.
34-50-20 PgBlk 1 (C)	Revised Description and Operation – Config C.
34-50-20 PgBlk 1 (D)	Description and Operation - Revised effectivity.
34-50-20 PgBlk 201	Added Transponder – Maintenance Practices.
34-50-20 PgBlk 501 (A)	Adjustment/Test - Revised General, Table 1 – Special Tools and Equipment, removed Barfield Altitude testing, Transponder Address Module Programming Procedure (AMC no longer supports this task). Revised Job Close-Up. – Config A. Added UC-584 antenna couplers to equipment table. Renamed existing procedures to with IFR-6000 Test Set Antenna. Added test procedures with UC-584 Antenna Coupler.
34-50-20 PgBlk 501 (B)	Adjustment/Test - Removed Barfield Altitude testing, Transponder and Avionics Cooling Fan Fault Checks (Standard System), and referenced Avionics Cooling Fan to AMM-34-50-24. Deleted Enhanced Downlinked Parameters test. – Config B. Added UC-584 antenna couplers to equipment table. Renamed existing procedures to with IFR-6000 Test Set Antenna. Added test procedures with UC-584 Antenna Coupler.
34-50-20 PgBlk 501 (C)	Adjustment/Test - Added Transponder Adjustment/Test for ADS-B Out. - Config C. Added UC-584 antenna coupler to equipment table. Renamed existing procedures to with IFR-6000 Test Set Antenna. Added test procedures with UC-584 Antenna Coupler.
34-50-21 PgBlk 1	Added ADS-B Out with GPS 3 – Description and Operation.

---

<b>CH/SE/SU Page Block No.</b>	<b>Description of Change</b>
34-50-21 PgBlk 501	Adjustment/Test - Added ADS-B Out check. Added antenna coupler to test.
34-50-21 PgBlk 401-Inst	Installation - Revised Job Set-Up.
34-50-23 PgBlk 401-Inst	Installation - Revised Job Close-up test reference.
34-50-26 PgBlk 401-Rem	Removal - Added ADS-B Fail Indicator Removal procedure.
34-50-26 PgBlk 401-Inst	Installation - Added ADS-B Fail Indicator Installation procedure.

THIS PAGE INTENTIONALLY LEFT BLANK

**FLIGHT ENVIRONMENT DATA - ADJUSTMENT/TEST**

AMM-34-10-00-071-801

**1. General**

- A. This task gives procedures to do an adjustment/test of the flight environment data components.

**NOTE:** This test procedure complies with the requirements of 14 CFR Part 43 Appendix E.

- (1) Unless indicated differently, the adjustment/test procedures are the same for both left and right sides.
- (2) Included are procedures for use of both the Barfield Pitot/Static Tester (Barfield, DPS450) and the Barfield Pitot/Static Tester (Barfield, DPS500).
- (3) After a replacement of the left and right Pitot/AOA probes, static ports, Air Data Computers (ADCs), Standby Pitot/Static probe and Outside Air Temperature (OAT) probes, do the test for each component shown in the table below.

**Table 501. Component Test Matrix**

Component to be Tested	Test
Left and right ADCs	<i>Pitot and Static System Leak Test</i> <a href="#">SUBTASK AMM-34-10-00-071-701-001</a> , <i>Pitot and Static Verification Test</i> <a href="#">SUBTASK AMM-34-10-00-071-701-005</a> and <i>Angle of Attack Test</i> <a href="#">SUBTASK AMM-34-10-00-071-701-004</a> and <a href="#">AMM-24-00-00-071-801 – Electrical Power - Adjustment/Test</a> , <a href="#">SUBTASK AMM-24-00-00-071-701-005</a> , Left and Right ADC Test. <b>If software only is replaced, perform the following:</b> <i>Pitot and Static Verification Test</i> <a href="#">SUBTASK AMM-34-10-00-071-701-005</a> .
Left and right Pitot/AOA probes	<i>Pitot and Static System Leak Test</i> <a href="#">SUBTASK AMM-34-10-00-071-701-001</a> , <i>Angle of Attack Test</i> <a href="#">SUBTASK AMM-34-10-00-071-701-004</a> and <a href="#">AMM-30-30-00-071-801 – Pitot and Static Anti-Ice System - Adjustment/Test</a> . <b>If software only is replaced, perform the following:</b> <i>Pitot and Static System Leak Test</i> <a href="#">SUBTASK AMM-34-10-00-071-701-001</a> , and <i>Angle of Attack Test</i> <a href="#">SUBTASK AMM-34-10-00-071-701-004</a> .
Left and right Static ports	<i>Pitot and Static System Leak Test</i> <a href="#">SUBTASK AMM-34-10-00-071-701-001</a> and <a href="#">AMM-30-30-00-071-801 – Pitot and Static Anti-Ice System - Adjustment/Test</a> .

EFFECTIVITY: NOTED

34-10-00

Component to be Tested	Test
Standby Pitot/Static probe	<i>Standby Pitot/Static Probe System Leak Test</i> <b>SUBTASK</b> <a href="#">AMM-34-10-00-071-701-002</a> , <i>Standby Pitot/Static Probe Verification Test</i> (Effectivity Noted) <b>SUBTASK</b> <a href="#">AMM-34-10-00-071-701-006</a> or <b>SUBTASK</b> <a href="#">AMM-34-10-00-071-701-007</a> and <a href="#">AMM-30-30-00-071-801 – Pitot and Static Anti-Ice System - Adjustment/Test</a> . <b>If software only is replaced, perform the following:</b> <i>Standby Pitot/Static Probe Verification Test</i> (Effectivity Noted) <b>SUBTASK</b> <a href="#">AMM-34-10-00-071-701-006</a> or <b>SUBTASK</b> <a href="#">AMM-34-10-00-071-701-007</a> .
Right and left OAT probes	<i>Outside Air Temperature Test</i> <b>SUBTASK</b> <a href="#">AMM-34-10-00-071-701-008</a> .

## 2. Equipment and Materials

**Table 502. Special Tools and Equipment**

Name and Part Number
Barfield Pitot/Static Tester (Barfield, DPS450) or Barfield Pitot/Static Tester (Barfield, DPS500) or Equivalent Tester.
Air Data Accessories Kit (NavAids P/N ADA500MD-945) (or) Air Data Accessories Kit ; (Nav Aids PN ADA500945) (Note: If using ADA500–945, covering pitot probes with tape is required)
Stop Watch (Inotek, EH365528) or Equivalent (Note: Calibrated with 1 second resolution)
Weight-on-Wheels (WOW) Box (EAI, 87-117390-1001) or Avio Maintenance Computer (AMC) (EAI 20-120576-1001 or 20-121926-1001), SW version “1.5.71 or higher” for Pre-Avio NG aircraft and “2.2.02 or higher” for Avio NG aircraft (for Weight off Wheels simulation)
Vinyl Tape (To cover drain hole on Pitot probes)
Ground Power Unit (GPU). AllStar 450 or AllStar G.S.E. or Hobart GPU-400 or Hobart GPU-600 or Bycan PS-28100 (Note: 28.0 ± 0.5 VDC)

### 3. Job Set-Up

SUBTASK AMM-34-10-00-071-921-001

\*\*\* ALL

- A. Make aircraft safe for maintenance. Refer to [AMM-20-00-01-051-801 – Make Safe For Maintenance](#).
- B. Apply external power to the aircraft. Refer to [AMM-24-40-00-051-801 – External Power - Maintenance Practices](#).

**CAUTION:** IF TRANSPONDER(S) NOT SET TO “STBY”, THE AIRCRAFT WILL CAUSE NUISANCE TRANSPONDER TRANSMISSIONS TO THE LOCAL AIRFIELD AND OTHER AIRCRAFT.

- D. When performing tests with the Weight On Wheels (WOW) box or Aircraft Maintenance Computer (AMC) for Weight off Wheels simulation, refer to [AMM-20-00-04-051-801 – Weight On Wheels \(WOW\) Box - Connect/Disconnect](#).
  - (1) Set both the left and right PFD Baro to 29.92 by pressing the BARO SET knob on the Autopilot Control Panel (ACP). Make sure the baro setting matches on the left and right PFD.
  - (2) Collar the following ECBs:

**WARNING: BECAUSE THIS TEST IS PERFORMED WITH WOFFW, THE HEATERS WILL BE COMMANDED ON BY THE SYSTEM. IF THE PITOT/STATIC HEAT ECBs ARE NOT COLLARED OFF, HARM TO PERSONNEL OR DAMAGE TO AIR DATA TEST EQUIPMENT CAN OCCUR.**

**NOTE:** ECBs can only be collared in the Weight-on-Wheels condition.

- (4) Collar the following ECB's:
  - ECB - WEATHER RADAR (L FWD Bus)
  - ECB - DEICE MANIFOLD HTR (R AFT Bus)
  - ECB - L PITOT HEAT (L FWD Bus) or ECB - L PITOT HEAT (BATT Bus)
  - ECB - R PITOT HEAT (R FWD Bus)
  - ECB - L STATIC HEAT (BATT Bus)
  - ECB - L STATIC HEAT (R FWD Bus)
  - ECB - R STATIC HEAT (R FWD Bus)
  - ECB - R STATIC HEAT (L FWD Bus)
  - ECB - STBY PITOT HEAT (BATT Bus) or ECB - STBY PITOT HEAT (L FWD)
  - ECB - L WINDSHIELD HEAT (L AFT Bus)
  - ECB - R WINDSHIELD HEAT (R AFT Bus)
- (5) Make sure that the ADC selection source is not displayed on the left PFD. Make sure that the ADC selection source is not displayed on the right PFD.

- (6) Set both the left and right PFD Baro to 29.92 by pressing the BARO SET knob on the Autopilot Control Panel (ACP). Make sure the baro setting matches on the left and right PFD.
- (7) Make sure that the ADC 3 is displayed on the MFD ADI.

**CAUTION:** IF TRANSPONDER(S) NOT SET TO “STBY”, THE AIRCRAFT WILL CAUSE NUISANCE TRANSPONDER TRANSMISSIONS TO THE LOCAL AIRFIELD AND OTHER AIRCRAFT.

#### 4. **Pitot and Static System Leak Test**

SUBTASK AMM-34-10-00-071-701-001

\*\*\* ALL

**CAUTION:** DO NOT PRESSURIZE THE AIRCRAFT DURING TESTING.

**NOTE:** If a Barfield Pitot/Static Tester DPS450 is used for this test complete paragraph A. If a Barfield Pitot/Static Tester DPS500 is used, go to paragraph B.

A. Pitot and Static System Leak Test with Barfield Pitot/Static Tester DPS450:

Procedure is given for the left side and is the same for the right side.

Refer to [Fig. 501, Sheet 1](#).

**CAUTION:** DO NOT OVER TIGHTEN HOSES. DAMAGE MAY OCCUR TO TEST EQUIPMENT. HOSES SHOULD BE SNUG.

**CAUTION:** THE LEAK TEST CAN BE ACCOMPLISHED WITH ELECTRICAL POWER OFF. MAKE SURE THAT IF THE WOW BOX IS CONNECTED, THE SWITCHES ARE SET TO WONW DURING THIS TEST IF ELECTRICAL POWER IS USED. WITH WEIGHT OFF WHEELS, THE HEATERS ARE COMMANDED ON BY THE AIRCRAFT COMPUTER SYSTEM. IF THE PITOT/STATIC HEAT ECBS ARE NOT COLLARED OFF, HARM TO PERSONNEL OR AIR DATA TEST EQUIPMENT CAN OCCUR.

**NOTE:** Refer to step (1) if using Air Data Accessories Kit ; (Nav Aids PN ADA500945) or step (2) if using Air Data Accessories Kit (NavAids P/N ADA500MD-945).

- (1) Connect the Barfield Pitot/Static Tester DPS450 to the aircraft using the Air Data Accessories Kit ; (Nav Aids PN ADA500945) as follows:
  - (a) Install the Pitot/Angle of Attack (AOA) Probe Adaptor (Nav Aids, APA94520-4-4-4) (7) with the label TOP facing up on the Pitot/AOA probe. If needed, lubricate with Pitot adaptor lubricating fluid (Part Number LF5050).

Adjust the Pitot/AOA Probe Adaptor nozzles to align with the holes of the Pitot/AOA probe.

**NOTE:** No other lubricating fluid is permitted. Malfunction of the equipment in flight is possible.

**NOTE:** When installing the pressure test adapters, make sure that the seal is good by applying a firm force to seat the adapter on the probe.

**NOTE:** The Pitot/AOA probes with a drain hole near the base of mast, must have the drain hole covered. The drain hole must be covered with teflon or vinyl tape. Failure to do so will result in a failure of this test.

(b) Connect the Pitot Test Hose Assembly (long hose) (3) to the Pt connection (2) on the Barfield Pitot/Static Tester DPS450. Connect the other end of the long hose to the quick-connect cross (4).

(c) Connect the Pitot Test Hose Assembly (three short hoses) (5, 6 and 8) to the quick-connect cross. Connect the other end of the short hoses to the upper, center and lower connections on the Pitot/AOA Probe Adaptor (7).

**NOTE:** Make sure that the Pitot/AOA Probe Adaptor nozzles are still aligned with the holes on the Pitot/AOA probe.

(d) Connect the Static Port Adaptor (Nav Aids, SS53515-4-4) (10) to the left static port and finger tighten the screws to seat the seals over the static ports.

(e) Connect the Static Test Hose Assembly ; (Nav Aids PN E500-5160) (long hose) (12) to the Barfield Pitot/Static Tester DPS450 Ps connection (1). Connect the other end of the Static Test Hose Assembly to the quick connect cross (11).

(f) Connect the (short hose) (9) to the top fitting of the Static Port Adaptor (Nav Aids, SS53515-4-4) (10). Connect the other end of the short hose to the quick connect cross (11).

(2) Connect the Barfield Pitot/Static Tester DPS450 to the aircraft using the Air Data Accessories Kit (NavAids P/N ADA500MD-945) as follows:

**NOTE:** When installing the pressure test adapters, make sure that the seal is good by applying a firm force to seat the adapter on the probe.

**NOTE:** The P22201MD-4 adapter contains a built-in seal that covers the Pitot/AOA probe drain hole. If using the P22201-3 adapter, the drain hole must be covered with teflon or vinyl tape.

**NOTE:** The Pitot/AOA probes with a drain hole near the base of the mast, must have the drain hole covered. Failure to do so will result in a failure of this test.

(a) Connect the Pitot Test Hose Assembly (3) to the Pt connection (2) on the Barfield Pitot/Static Tester DPS450. DO NOT OVERTIGHTEN.

(b) Connect the opposite end of the hose to the NAV Aids P22201MD-4 adapter.

(c) Install the NAV Aids P22201MD-4 adapter to the Pitot/AOA Probe. Make sure that the internal seal of the adapter covers the pitot probe drain hole. If using the

P22201-3 adapter, make sure that the pitot probe drain hole is covered with tape. If needed, lubricate with Pitot adaptor lubricating fluid (Part Number LF5050).

**NOTE:** No other lubricating fluid is permitted. Malfunction of the equipment in flight is possible.

- (d) Connect the Static Port Adaptor (Nav Aids, SS53515-4-4) (10) to the left static port and finger tighten the screws to seat the seals over the static ports.
  - (e) Connect the Static Test Hose Assembly ; (Nav Aids PN E500-5160) (long hose) (12) to the Barfield Pitot/Static Tester DPS450 Ps connection (1).
  - (f) Connect the other end of the hose (9) to the top fitting of the Static Port Adaptor (Nav Aids, SS53515-4-4) (10).
- (3) Use tape to seal the opposite-side Static port.
- NOTE:** Make sure to select a tape that does not leave any adhesive residue on the static port when the test is complete.
- (4) Power on the Barfield Pitot/Static Tester DPS450. Wait for the Barfield Pitot/Static Tester DPS450 to the Confirm Settings.
- After a successful self-test sequence, the system changes to the Leak Measure mode.
- NOTE:** Skip this step if the Barfield Pitot/Static Tester DPS450 is in Quad mode. Quad mode displays four values: ALT, ROC, CAS, and Rt CAS.
- (5) Press Setup and press F1 to select Display. Press F3 to select Quad. Make sure that Alt is in ft, CAS is in kts and Rt CAS is in kts/min. If not, press F2 to select Units and then press F1 to select ft kts ft/min and press F4 to save settings. Press Clear/Quit to return to Main Menu displayed in the upper right corner.
  - (6) Press LEAK MEASURE/ CONTROL for CONTROL MODE.
  - (7) Press F1 to select Rate Timer and then press F3 to select Set Wait.
  - (8) Press 5 and then press Enter.
    - The Set Wait will be updated to 5 minutes.
  - (9) Press F4 to select Set Time, press 1, and then press Enter.
    - The Set Time will be updated to 1 minute.
  - (10) Press CLEAR/QUIT to return to Main Menu.
  - (11) Press ROC RATE Ps to select the ROC control aim, enter 4000 and press the Enter button.
  - (12) Press ALT Ps to select the ALT control aim, enter 30000 and press the Enter button.
    - The system starts to control to the new set point.
  - (13) Press SPEED Qc, enter 200 and press Enter. Wait for at least a 15 second stabilization period after the altitude and airspeed achieve these new air data parameter set point values to continue.
  - (14) Press LEAK MEASURE/CONTROL to change to LEAK MEASURE MODE.
  - (15) Press F1 twice to Start Timing.

- After the Waiting and Timing intervals are complete, the Barfield Pitot/Static Tester DPS450 displays Timed Rates Available.
- (16) Check that the maximum ROC is 100 ft/min or less and the maximum Rt CAS is 2 kts/min. or less.
- If the leak rate is not within tolerances, refer to Leak Testing in the Barfield Pitot/Static Tester DPS450 and Connecting Hoses ([SUBTASK AMM-34-10-00-071-701-003](#)). Subtract the Barfield Pitot/Static Tester DPS450 leak check altitude value recorded in Leak Testing in the Barfield Pitot/Static Tester DPS450 and Connecting Hoses subtask from the value obtained in this section in order to get a corrected total system leak value.
- (17) Press LEAK MEASURE/CONTROL to return to CONTROL MODE.
- (18) If no further maintenance is required, remove all of the Nav Aids test equipment from the aircraft. Stow the Air Data Accessories Kit ; (Nav Aids PN ADA500945) equipment and Barfield Pitot/Static Tester DPS450.
- (19) Remove the tape from the opposite-side Static port.

**B. Pitot and Static System Leak Test with Barfield Pitot/Static Tester DPS500:**

Procedure is given for the left side and is the same for the right side unless noted.

**NOTE:** To use the Barfield Pitot/Static Tester DPS500 Remote during this test, connect the Remote (P/N ADTS405-1728-37M0) and Remote Cord (P/N ADTS405-1728-28M0) to the Barfield Pitot/Static Tester DPS500 Hand Terminal Connection.

**NOTE:** The Pt Hose (p/n ADTS405-1729-62m0) may be used in place of the hose (p/n E500-7270). The AN6-AN4 adaptor is not needed if using the ADTS405-1729-62m0 Pt hose.

**NOTE:** The Ps Hose (p/n ADTS405-1729-61m0) may be used in place of the hose (p/n E500-5160), The AN6-AN4 connector is not required if using this configuration. Install a AN5 to AN4 adaptor on the Barfield DPS500 Ps connection.

**CAUTION:** DO NOT OVER TIGHTEN HOSES. DAMAGE MAY OCCUR TO TEST EQUIPMENT. HOSES SHOULD BE SNUG.

**CAUTION:** THE LEAK TEST CAN BE DONE WITH ELECTRICAL POWER OFF. MAKE SURE THAT IF THE WOW BOX IS CONNECTED, THE SWITCHES ARE SET TO WONW DURING THIS TEST IF ELECTRICAL POWER IS USED. WITH WEIGHT OFF WHEELS, THE HEATERS ARE COMMANDED ON BY THE AIRCRAFT COMPUTER SYSTEM. IF THE PITOT/STATIC HEAT ECBS ARE NOT COLLARED OFF, HARM TO PERSONNEL OR AIR DATA TEST EQUIPMENT CAN OCCUR.

**NOTE:** Refer to step (1) if using the Air Data Accessories Kit ; (Nav Aids PN ADA500945) or step (2) if using the Air Data Accessories Kit (NavAids P/N ADA500MD-945).

- (1) Connect the Barfield Pitot/Static Tester DPS500 to the aircraft as follows:
- (a) Install the Pitot/Angle of Attack (AOA) Probe Adaptor (Nav Aids, APA94520-4-4-4) (7) with the label TOP facing up on the Pitot/AOA probe. If

needed, lubricate with Pitot adaptor lubricating fluid (Part Number LF5050). Adjust the Pitot/AOA Probe Adaptor nozzles to align with the holes of the Pitot/AOA probe.

**NOTE:** No other lubricating fluid is allowed, possible malfunction of the equipment in flight is possible

**NOTE:** When installing the pressure test adapters, make sure of a good seal by applying a firm force to seat the adapter on the probe.

**NOTE:** If present, cover the probe drain hole with vinyl tape.

- (b) Connect the Pitot Test Hose Assembly (long hose) (3) to the Pt connection (2) on the Barfield Pitot/Static Tester DPS500. Connect the other end of the long hose (3) to the quick connect cross (4).
- (c) Connect the Pitot Test Hose Assembly (one short hose) (5) to the quick connect cross (4). Connect the other end of the short hose (5) to the center connection on the Pitot/AOA Probe Adaptor (7).

**NOTE:** Make sure that the Pitot/AOA Probe Adaptor nozzles are still aligned with the holes on the Pitot/AOA probe.

- (d) Connect the Static Test Hose Assembly ; (Nav Aids PN E500-5160) (12) to the Barfield Pitot/Static Tester DPS500 Ps connection (1).
- (e) Connect the other end of the Static Test Hose Assembly (12) to the top fitting of the Static Port Adaptor (Nav Aids, SS53515-4-4) (10).
- (f) Connect the Static Port Adaptor (Nav Aids, SS53515-4-4) (10) to the left Static port with the connected fitting to the top port and finger tighten the screws to seat the seals over the Static ports.

**NOTE:** The right static upper port can be tested from the left Static lower port by connecting the short hose to the lower port connection on the Static Port Adaptor. The aircraft's left lower port is connected to the right upper port and the left upper port is connected to the right lower port by aircraft design. Refer to [Fig. 504, Sheet 1](#).

- (2) Connect the Barfield Pitot/Static Tester DPS500 to the aircraft using the Air Data Accessories Kit (NavAids P/N ADA500MD-945) as follows:

**NOTE:** When installing the pressure test adapters, make sure that the seal is good by applying a firm force to seat the adapter on the probe.

**NOTE:** The P22201MD-4 adapter contains a built-in seal that covers the Pitot/AOA probe drain hole. If using the P22201-3 adapter, the drain hole must be covered with teflon or vinyl tape.

**NOTE:** The Pitot/AOA probes with a drain hole near the base of the mast, must have the drain hole covered. Failure to do so will result in a failure of this test.

- (a) Connect the Pitot Test Hose Assembly (3) to the Pt connection (2) on the Barfield Pitot/Static Tester DPS500. DO NOT OVERTIGHTEN.
- (b) Connect the opposite end of the hose to the NAV Aids P22201MD-4 adapter.
- (c) Install the NAV Aids P22201MD-4 adapter to the Pitot/AOA Probe. Make sure that the internal seal of the adapter covers the pitot probe drain hole. If using the

P22201-3 adapter, make sure that the pitot probe drain hole is covered with tape. If needed, lubricate with Pitot adaptor lubricating fluid (Part Number LF5050).

**NOTE:** No other lubricating fluid is permitted. Malfunction of the equipment in flight is possible.

- (d) Connect the Static Test Hose Assembly ; (Nav Aids PN E500-5160) (12) to the Barfield Pitot/Static Tester DPS500 Ps connection (1) .
  - (e) Connect the other end of the Static Test Hose Assembly (12) to the top fitting of the Static Port Adaptor (Nav Aids, SS53515-4-4) (10) .
  - (f) Connect the Static Port Adaptor (Nav Aids, SS53515-4-4) (10) to the left Static port with the connected fitting to the top port and finger tighten the screws to seat the seals over the Static ports.
- (3) Use tape to seal the opposite-side static port.
- NOTE:** Make sure to select a tape that does not leave any adhesive residue on the Static port when the test is complete.
- (4) Power on the Barfield Pitot/Static Tester DPS500 by selecting OPERATE and PUMP switches to ON. Wait for the Barfield Pitot/Static Tester DPS500 to confirm the settings.
- After a successful self-test sequence, the system changes to the Warm Up mode.
- (5) Press ROC Ps RATE to select the ROC control aim, enter 4000 and press the Enter button.
- (6) Press ALT Ps to select the ALT control aim, enter 30000 and press the Enter button.
- The system starts to control to the new set point.
- (7) Press SPEED Qc and enter 200 then press Enter. Wait for at least a 15 second stabilization period after the altitude and airspeed achieve these new air data parameter set point values to continue.
- (8) Press LEAK MEASURE/CONTROL to change to LEAK MEASURE MODE.
- (9) Press RATE TIMER.
- (10) Press F3.
- After the Waiting and Timing intervals are complete, the Barfield Pitot/Static Tester DPS500 displays Timed Rates.
- (11) Check that the maximum ROC is 100 ft/min or less and the maximum Rt CAS is 2 kts/min or less.
- If the leak rate is not within tolerances, refer to Leak Testing in the Barfield Pitot/Static Tester DPS500 and Connecting Hoses [SUBTASK AMM-34-10-00-071-701-003](#) and subtract the Barfield Pitot/Static Tester DPS500 leak check altitude value recorded in Leak Testing the Barfield Pitot/Static Tester DPS500 and Connecting Hoses subtask from the value obtained in this section in order to get a corrected total system leak value.
- (12) Press LEAK MEASURE/CONTROL to return to CONTROL MODE.

- (13) If no further maintenance is required, remove all of the Nav Aids test equipment from the aircraft. Stow all the Air Data Accessories Kit ; (Nav Aids PN ADA500945) equipment and the Barfield Pitot/Static Tester DPS500.
- (14) Remove the tape from the opposite-side Static port.

## 5. **Standby Pitot/Static Probe System Leak Test**

SUBTASK AMM-34-10-00-071-701-002

\*\*\* ALL

**CAUTION:** DO NOT PRESSURIZE THE AIRCRAFT DURING TESTING.

**NOTE:** If a Barfield Pitot/Static Tester DPS450 is used for this test complete paragraph A. If a Barfield Pitot/Static Tester DPS500 is used, go to paragraph B.

- A. Complete the Standby Pitot/Static System Leak Test (using the Barfield Pitot/Static Tester DPS450) as follows:

**CAUTION:** DO NOT OVER TIGHTEN HOSES. DAMAGE MAY OCCUR TO TEST EQUIPMENT. HOSES SHOULD BE SNUG.

**CAUTION:** THE LEAK TEST CAN BE ACCOMPLISHED WITH ELECTRICAL POWER OFF. MAKE SURE THAT IF THE WOW BOX IS CONNECTED, THE SWITCHES ARE SET TO WONW DURING THIS TEST IF ELECTRICAL POWER IS USED. WITH WEIGHT OFF WHEELS, THE HEATERS ARE COMMANDED ON BY THE AIRCRAFT COMPUTER SYSTEM. IF THE PITOT/STATIC HEAT ECBS ARE NOT COLLARED OFF, HARM TO PERSONNEL OR AIR DATA TEST EQUIPMENT CAN OCCUR.

**NOTE:** Refer to step (1) if using the Air Data Accessories Kit ; (Nav Aids PN ADA500945) or step (2) if using the Air Data Accessories Kit (NavAids P/N ADA500MD-945).

- (1) Connect the Barfield Pitot/Static Tester DPS450 to the aircraft Standby Pitot/Static probe as follows:
  - (a) Attach the Pitot/Static probe adaptor (PS35210-4-4) (6) to the Standby Pitot/Static probe.
  - (b) Connect the hose (3) from the Pt connection (2) on the Barfield Pitot/Static Tester DPS450 to the end fitting on the Pitot/Static probe adaptor (PS35210-4-4) (6) .
  - (c) Connect the hose from the Ps (1) connection on the Barfield Pitot/Static Tester DPS450 to the fitting on the side on the Pitot/Static probe adaptor (PS35210-4-4) (6) .

**NOTE:** Cover the probe drain hole with vinyl tape.

- (2) Connect the Barfield Pitot/Static Tester DPS500 to the aircraft using the Air Data Accessories Kit (NavAids P/N ADA500MD-945) as follows:

- (a) Remove the P22201MD-4 adapter (or the P22201-3 adapter) from the Pt Hose. Connect the hose from the Pt adapter on the Barfield to PS35210MD-4-4 adapter (or PS35210-4-4 adapter) connector marked PITOT (this is the connector at the end of the adapter).
- (b) Disconnect the hose from the static PTA and connect to the other PS35210 connector (connector on side of adapter). Connect the PS35210 adapter to the Pitot/Static probe, make sure of a complete coverage of the static ports on the Pitot/Static probe.

**NOTE:** The PS35210MD-4-4 adapter contains a built-in seal that covers the pitot static probe drain hole. If using the PS35210-4-4 adapter, the drain hole must be covered with vinyl tape.

**NOTE:** The Pitot/Static probe is the upper pitot probe on the left hand side.

- (3) Press CLEAR/QUIT to return to main menu on Barfield Pitot/Static Tester DPS450.
- (4) Press F1 to select Rate Timer and then press F3 to select Set Wait.
- (5) Press 5 and then press ENTER.
  - The Set Wait will be updated to 5 minutes.
- (6) Press F4 to select Set Time, press 1, and then press ENTER.
  - The Set Time will be updated to 1 minute.
- (7) Press CLEAR/ QUIT to return to Main Menu.
- (8) Press LEAK MEASURE/ CONTROL for CONTROL MODE.
- (9) Press ROC RATE Ps to select the ROC control aim, enter 4000 and press Enter.
- (10) Press ALT Ps to select the ALT control aim, enter 30000 and press Enter.
  - The system starts to control to the new set point.
- (11) Press SPEED Qc, enter 200 and press Enter. Wait for at least a 15 second stabilization period after the altitude and airspeed achieve these new air data parameter set point values to continue.
- (12) Press LEAK MEASURE/CONTROL to change to LEAK MEASURE MODE.
- (13) Press F1 twice to Start Timing.
  - After the Waiting and Timing intervals are complete, the Barfield Pitot/Static Tester DPS450 displays Timed Rates Available.
- (14) Check the maximum ROC is 100 ft/min or less and the maximum Rt CAS is 2 kt/min or less.
  - If the leak rate is not within tolerances, refer to Leak Testing the Barfield Pitot/Static Tester DPS450 and Connecting Hoses ([SUBTASK AMM-34-10-00-071-701-003](#)) and subtract the Barfield Pitot/Static Tester DPS450 leak check altitude value recorded in Leak Testing the Barfield Pitot/Static Tester DPS450 and Connecting Hoses [SUBTASK AMM-34-10-00-071-701-003](#) from the value obtained in this section in order to get a corrected total system leak value.
- (15) Press the LEAK MEASURE/CONTROL to return to CONTROL MODE.

- (16) If no further maintenance is required, remove all of the Nav Aids test equipment from the aircraft. Stow the Air Data Accessories Kit ; (Nav Aids PN ADA500945) equipment and Barfield Pitot/Static Tester DPS450.
- B. Complete the Standby Pitot/Static System Leak Test (using the Barfield Pitot/Static Tester DPS500) as follows:

**CAUTION:** DO NOT OVER TIGHTEN HOSES. DAMAGE MAY OCCUR TO TEST EQUIPMENT. HOSES SHOULD BE SNUG.

**CAUTION:** THE LEAK TEST CAN BE ACCOMPLISHED WITH ELECTRICAL POWER OFF. MAKE SURE THAT IF THE WOW BOX IS CONNECTED, THE SWITCHES ARE SET TO WONW DURING THIS TEST IF ELECTRICAL POWER IS USED. WITH WEIGHT OFF WHEELS, THE HEATERS ARE COMMANDED ON BY THE AIRCRAFT COMPUTER SYSTEM. IF THE PITOT/STATIC HEAT ECBS ARE NOT COLLARED OFF, HARM TO PERSONNEL OR AIR DATA TEST EQUIPMENT CAN OCCUR.

**NOTE:** Refer to step (1) if using the Air Data Accessories Kit ; (Nav Aids PN ADA500945) or step (2) if using the Air Data Accessories Kit (NavAids P/N ADA500MD-945).

- (1) Connect the Barfield Pitot/Static Tester DPS450 to the aircraft Standby Pitot/Static probe as follows:
- (a) Attach the Pitot/Static probe adaptor (PS35210-4-4) (6) to the Standby Pitot/Static probe.
  - (b) Connect the hose (3) from the Pt connection (2) on the Barfield Pitot/Static Tester DPS450 to the end fitting on the Pitot/Static probe adaptor (PS35210-4-4) (6) .
  - (c) Connect the hose from the Ps (1) connection on the fitting on the side on the Pitot/Static probe adaptor (PS35210-4-4) (6) .

**NOTE:** Cover the probe drain hole with vinyl tape.

- (2) Connect the Barfield Pitot/Static Tester DPS500 to the aircraft using the Air Data Accessories Kit (NavAids P/N ADA500MD-945) as follows:
- (a) Remove the P22201MD-4 adapter (or the P22201-3 adapter) from the Pt Hose. Connect the hose from the Pt adapter on the Barfield to the PS35210MD-4-4 adapter (or PS35210- 4-4 adapter) connector marked PITOT (this is the connector at the end of the adapter).
  - (b) Disconnect the hose from the static PTA and connect to the other PS35210 connector (connector on the side of the adapter). Connect the PS35210 adapter to the Pitot/Static probe, make sure of complete coverage of the static ports on the Pitot/Static probe.

**NOTE:** The PS35210MD-4-4 adapter contains a built-in seal that covers the pitot static probe drain hole. If using the PS35210-4-4 adapter, the drain hole must be covered with vinyl tape.

**NOTE:** The Pitot/Static probe is the upper pitot probe on the left hand side.

- (3) Press LEAK MEASURE/ CONTROL for CONTROL MODE.
- (4) Press ROC RATE Ps to select the ROC control aim, enter 4000 and press Enter.
- (5) Press ALT Ps to select the ALT control aim, enter 30000 and press Enter.
  - The system starts to control to the new set point.
- (6) Press SPEED Qc and enter 200 then press ENTER. Wait for at least a 15 second stabilization period after the altitude and airspeed achieve these new air data parameter set point values to continue.
- (7) Press LEAK MEASURE/CONTROL to change to LEAK MEASURE MODE.
- (8) Press RATE TIMER.
- (9) .Press F3
  - After the Waiting and Timing intervals are complete, the DPS500 will display Timed Rates.
- (10) Check the maximum ROC is 100 ft/min or less and the maximum Rt CAS is 2 kt/min or less.
- (11) Press the LEAK MEASURE/CONTROL to return to CONTROL MODE.
- (12) If no further maintenance is required, remove all of the Nav Aids test equipment from the aircraft. Stow all the Air Data Accessories Kit ; (Nav Aids PN ADA500945) equipment and Barfield Pitot/Static Tester DPS500.

## **6. Leak Testing the Barfield Pitot/Static Tester DPS450 and Connecting Hoses.**

SUBTASK AMM-34-10-00-071-701-003

\*\*\* ALL

- A. If leakage is excessive during the left and right Pitot and Static System Leak Test for unpressurized aircraft, do the following test with the Barfield Pitot/Static Tester DPS450:

**CAUTION: DO NOT OVER TIGHTEN HOSES. DAMAGE MAY OCCUR TO TEST EQUIPMENT. HOSES SHOULD BE SNUG.**

- (1) Connect the Nav Aids Hose E500-7270 (approximately 8 feet long) to the Barfield Pitot/Static Tester DPS450 Pt connector. Connect the other end of the E500-7270 to the Pitot/AOA pressure test hose fitting. Connect the pressure test hose fitting to the PT421-4520 Pre-Test Probe.
- (2) Connect the Nav Aids Hose E500-5160 (approximately 4 feet long) or (E500-5170 is acceptable) to the Barfield Pitot/Static Tester DPS450 Ps connector. Connect the other end of the E500-5160 to the Static Port Adaptor (Nav Aids, SS53515-4-4). Connect the Static Test Adaptor to the PTS515 Pre-Test Plate.
- (3) Power on the Barfield Pitot/Static Tester DPS450. Wait two minutes for the Barfield Pitot/Static Tester DPS450 to confirm the settings.
  - After a successful self-test sequence, the system changes to the Leak Measure mode.

- (4) Skip this step if the Barfield Pitot/Static Tester DPS450 is in Quad mode. Quad mode will display four values: Ps, RtPc, Qc, RtQc. Press SETUP, press F1 to select Display. Press F3 to select Quad. Make sure that Alt is in ft, CAS is in kts and Rt CAS is in kts/min. If not, press F2 to select Units, press F1 to select ft Kts ft/min and press F4 to save settings. Press Clear/Quit to return to the Main Menu displayed in the upper right corner.
- (5) Press ALT Ps, ROC RATE Ps, SPEED Qc, and RATE to display the appropriate air data parameters.
- (6) Press CLEAR QUIT for the Main Menu displayed in the upper right corner. Several attempts of pressing the CLEAR/QUIT button may be needed to return to the Main Menu.
- (7) Press LEAK MEASURE/CONTROL to scroll to the CONTROL MODE displayed in lower left corner.
- (8) Press ROC RATE Ps to select the ROC control aim. Using the keypad, enter 4000 and press ENTER. Press ALT Ps to select the altitude control aim, enter 10000 and press ENTER.
  - The ROC and ALT control aim values will be updated.
- (9) Press SPEED Qc, enter 200 then press ENTER. Wait for at least a 15 second stabilization period after the ROC and CAS achieves the new air data parameter set points values before moving to the next step.
- (10) Press LEAK MEASURE/CONTROL to change to LEAK MEASURE MODE.
- (11) Press F1 to select Rate Timer and then press F3 to select Set Wait. Press 0.3 and then Enter.
- (12) Press F4 to select Set Time, press 0.3 and then ENTER.
  - The Set Wait and Set Time will both be updated to 00m.30s.
- (13) Press F1: Start Timer.
  - The display starts the count down Waiting timer followed by the Timing timer. After the Timing timer has expired, the ROC and Rt CAS will display Timed Leak Measure with the final values. Record these values.
  - Make sure that the ROC is less than  $\pm 25$  ft/min and Rt CAS is less than  $\pm 0.25$  kt/min.
- (14) Press CLEAR QUIT to return to the main menu.
- (15) Press LEAK MEASURE/CONTROL to return to CONTROL MODE.
- (16) Press GROUND to go to atmospheric pressure. Press F1 to select [Yes] to confirm.
- (17) After the Barfield Pitot/Static Tester DPS450 displays the SAFE AT GROUND prompt, power off the test set and remove the hose caps.
- (18) Return to the test section previously run to incorporate the values from Leak Testing the Barfield Pitot/Static Tester DPS450 and Connecting Hoses section.

---

## 7. Angle of Attack Test

SUBTASK AMM-34-10-00-071-701-004

\*\*\* ALL

NOTE: If a Barfield Pitot/Static Tester DPS450 is used for this test complete paragraph A. If a Barfield Pitot/Static Tester DPS500 is used, go to paragraph B.

A. Angle of Attack Test with the Barfield Pitot/Static Tester DPS450:

Procedure is given for the left side and is the same for the right side.

Refer to [Fig. 502, Sheet 1](#)

- (1) Connect the WOW Box or AMC to the aircraft and make sure that the ECB's are collared. Refer to [SUBTASK AMM-34-10-00-071-921-001](#).
- (2) Select WOffW on the WOW test box or select WOffW on the AMC.
- (3) Set the transponder to STBY on the PFD.
- (4) Make sure both the left and right PFD baro are set to 29.92 by using the BARO SET knob on the (ACP) Autopilot Control Panel. Also make sure that the baro setting matches on the left and right PFD.

NOTE: Refer to step (5) if using the Air Data Accessories Kit ; (Nav Aids PN ADA500945) or step (6) if using the Air Data Accessories Kit (NavAids P/N ADA500MD-945).

- (5) Connect the Barfield Pitot/Static Tester DPS450 to the aircraft using the Air Data Accessories Kit ; (Nav Aids PN ADA500945) as follows:

CAUTION: DO NOT OVER TIGHTEN HOSES. DAMAGE MAY OCCUR TO TEST EQUIPMENT. HOSES SHOULD BE SNUG.

NOTE: The Pitot/AOA probes with a drain hole near the base of mast, must have the drain hole covered. Failure to do so will result in a failure of this test.

- (a) Install the Pitot/Angle of Attack (AOA) Probe Adaptor (Nav Aids, APA94520-4-4-4) [\(7\)](#) with the label TOP facing up on the Pitot/AOA probe. If needed, lubricate with Pitot adaptor Lubricating fluid Part Number LF5050. Adjust the Pitot/AOA Probe Adaptor nozzles to align with the holes of the Pitot/AOA probe.
- (b) Connect the Pitot Test Hose Assembly (long hose) [\(3\)](#) to the Pt connection [\(2\)](#) on the Barfield Pitot/Static Tester DPS450. Connect the other end of the long hose [\(3\)](#) to the quick-connect cross [\(4\)](#).
- (c) Connect the Pitot Test Hose Assembly (two short hoses) [\(5 and 6\)](#) to the quick-connect cross [\(4\)](#). Connect the other ends of the two short hoses [\(5 and 6\)](#) to the center and lower connections on the Pitot/AOA Probe Adaptor [\(7\)](#).

NOTE: Make sure that the Pitot/AOA Probe Adaptor nozzles are still aligned with the holes on the Pitot/AOA probe.

- (6) Connect the Barfield Pitot/Static Tester DPS450 to the aircraft using the Air Data Accessories Kit (NavAids P/N ADA500MD-945) as follows:

- (a) Remove the PS35210 Pressure Test Adaptor from the Pitot/Static probe.
  - (b) Remove the E500-7270 hose from the PITOT (end) connector of the PS35210 adapter and connect to a NAV Aids quick connect cross (leave other end of hose connected to the Barfield Pt connector). Connect (2) LH and/or RH MFP Pitot hoses approximately 2 ft long to the quick disconnect cross and then to the Middle and Lower Nozzles of the NAV Aids APA94520MD-4-4-4 (or APA94520-4-4-4) Pressure Test Adaptor.
  - (c) Connect another LH and/or RH MFP pitot hose approximately 2 ft long to the upper nozzle of the APA94250 adapter. Connect the other end to a second NAV Aids quick connect cross.
  - (d) Remove the other hose from the PS35210 pitot/static test adaptor and connect it to the same quick connect cross as the upper hose of the APA94520 adapter.
  - (e) Attach an E500-5160 hose to the upper static test adaptor. Attach the other end of the hose to the quick connect cross that is connected to the upper hose of the APA94520 Pitot/AOA test adaptor.
  - (f) If needed Lubricate with Pitot adaptor Lubricating fluid Part # LF5050 (NOTE: No other lubricating fluid is allowed) Insert an APA94520 adapter onto the Left Pitot probe and adjust the PTA nozzles to align with the holes of the Pitot/AOA Probe and adjust until the seals are snug. ( DO NOT over tighten)
- (7) Power on the Barfield Pitot/Static Tester DPS450 (if needed).
    - Wait for the Barfield Pitot/Static Tester DPS450 to finish a sequence of pneumatic and internal system checks and the system changes to the Leak Measure mode (shown, lower left display corner).
  - (8) Press LEAK MEASURE/CONTROL to select the CONTROL MODE.
  - (9) Press ALT Ps, enter 6000, and press Enter.
  - (10) Select F2 UNITS then select F3 inHg.
    - Units on the display change from kts/min to inHg.
  - (11) Press SPEED Qc, enter 0.5 inHg, and press Enter.
    - Wait for at least a 15 second stabilization period after the Barfield achieves this new air data set point value (within  $\pm 2$  feet &  $\pm 0.010$  inHg).
  - (12) Record the airspeed on the left PFD.
    - Expected results are 105.5 kts  $\pm$  2.5 kts.
  - (13) Press GROUND to go to the atmospheric pressure. Press F1 to select Yes to confirm.
    - The Barfield Pitot/Static Tester DPS450 displays shows for SAFE AT GROUND.
  - (14) Power off the Barfield Pitot/Static Tester DPS450.
  - (15) If no further maintenance is required, remove all of the Nav Aids test equipment from the aircraft. Stow the Air Data Accessories Kit equipment and Barfield Pitot/Static Tester DPS450. Also, refer to [SUBTASK AMM-34-10-00-071-921-002](#).

**B. Angle of Attack Test with the Barfield Pitot/Static Tester DPS500:**

Procedure is given for the left side and is the same for the right side.

- (1) Connect the WOW Box or AMC to the aircraft and make sure that the ECB's are collared. Refer to [SUBTASK AMM-34-10-00-071-921-001](#).
- (2) Select WOffW on the WOW test box or select WOffW on the AMC.
- (3) Make sure both the left and right PFD baro are set to 29.92 by using the BARO SET knob on the ACP. Make sure the baro setting matches on the left and right PFD.

NOTE: Refer to step (4) if using the Air Data Accessories Kit ; (Nav Aids PN ADA500945) or step (5) if using the Air Data Accessories Kit (NavAids P/N ADA500MD-945).

- (4) Connect the Barfield Pitot/Static Tester DPS500 to the aircraft using the Air Data Accessories Kit ; (Nav Aids PN ADA500945) as follows:

CAUTION: DO NOT OVER TIGHTEN HOSES. DAMAGE MAY OCCUR TO TEST EQUIPMENT. HOSES SHOULD BE SNUG.

NOTE: The Pitot/AOA probes with a drain hole near the base of mast, must have the drain hole covered. Failure to do so will result in a failure of this test.

NOTE: The Pt Hose (ADTS405-1729- 62m0) may be used in place of the hose (E500-7270). An AN6 – AN4 adaptor is not needed if using the ADTS405-1729-62m0 Pt hose.

- (a) Install the Pitot/Angle of Attack (AOA) Probe Adaptor (Nav Aids, APA94520-4-4-4) (7) with the label TOP facing up on the Pitot/AOA probe. If needed, lubricate with Pitot adaptor Lubricating fluid Part Number LF5050. Adjust Pitot/AOA Probe Adaptor nozzles to align with the holes of the Pitot/AOA probe.
- (b) Connect the Pitot Test Hose Assembly (long hose) (3) to the Pt connection (2) on the Barfield Pitot/Static Tester DPS500. Connect the other end of the long hose (3) to the quick-connect cross (4) .
- (c) Connect the Pitot Test Hose Assembly (two short hoses) (5 and 6) to the quick-connect cross (4) . Connect the other ends of the two short hoses (5 and 6) to the center and lower connections on the Pitot/AOA Probe Adaptor (7) .

NOTE: Make sure that the Pitot/AOA Probe Adaptor nozzles are still aligned with the holes on the Pitot/AOA probe.

- (5) Connect the Barfield Pitot/Static Tester DPS500 to the aircraft using the Air Data Accessories Kit (NavAids P/N ADA500MD-945) as follows:
  - (a) Remove the PS35210 Pressure Test Adaptor from the Pitot/Static probe.
  - (b) Remove the E500-7270 hose from the PITOT (end) connector of the PS35210 adaptor and connect to a NAV Aids quick connect cross (leave other end of hose connected to the Barfield Pt connector). Connect (2) LH and/or RH MFP Pitot hoses approximately 2 ft long to the quick disconnect cross and then to the Middle and Lower Nozzles of the NAV Aids APA94520MD-4-4-4 (or APA94520-4-4-4) Pressure Test Adaptor.

- (c) Connect another LH and/or RH MFP pitot hose approximately 2 ft long to the upper nozzle of the APA94250 adapter. Connect the other end to a second NAV Aids quick connect cross.
  - (d) Remove the other hose from the PS35210 pitot/static test adaptor and connect it to the same quick connect cross as the upper hose of the APA94520 adapter.
  - (e) Attach an E500-5160 hose to the upper static test adaptor. Attach the other end of the hose to the quick connect cross that is connected to the upper hose of the APA94520 Pitot/AOA test adaptor.
  - (f) If needed Lubricate with Pitot adaptor Lubricating fluid Part # LF5050 (NOTE: No other lubricating fluid is allowed) Insert the APA94520 adapter onto the Left Pitot probe and adjust the PTA nozzles to align with the holes of the Pitot/AOA Probe and adjust until the seals are snug. (DO NOT over tighten)
- (6) Power on the Barfield Pitot/Static Tester DPS500 by flipping the Operate & Pump toggle switches.
    - Wait for the Barfield Pitot/Static Tester DPS500 to finish a sequence of pneumatic and internal system checks and the system changes to the Leak Measure mode (shown, lower left display corner).
  - (7) Press LEAK MEASURE/CONTROL to select the CONTROL MODE.
  - (8) Press ALT Ps, enter 6000, and press Enter.
  - (9) Press SETUP.
    - Units on the display change from kts/min to inHg.
  - (10) Press F1 (UNITS).
  - (11) Press F1 (Next) 6 times until inHg is displayed.
  - (12) Press F4 (Save).
  - (13) Press CLEAR QUIT twice
  - (14) Press SPEED Qc, enter 0.5 inHg, and press Enter.
    - Wait for at least a 15 second stabilization period after the Barfield Pitot/Static Tester DPS500 achieves this new air data set point value to continue.
  - (15) Record the airspeed on the left PFD.
    - Expected results are 105.5 knots  $\pm$  2.5 kts.
  - (16) Press GROUND to go to atmospheric pressure. Press F1 to select Yes to confirm.
    - The Barfield Pitot/Static Tester DPS500 displays shows for SAFE AT GROUND.
  - (17) Press CLEAR QUIT.
  - (18) Power off the Barfield Pitot/Static Tester DPS500.
  - (19) If no further maintenance is required, remove all of the Nav Aids test equipment from the aircraft. Stow all air data equipment and the Barfield Pitot/Static Tester DPS450. Also, refer to [SUBTASK AMM-34-10-00-071-921-002](#).

## 8. Pitot and Static Verification Test

SUBTASK AMM-34-10-00-071-701-005

\*\*\* ALL

**NOTE:** If a Barfield Pitot/Static Tester DPS450 is used for this test complete paragraph A. If a Barfield Pitot/Static Tester DPS500 is used, go to paragraph B.

A. Pitot and Static Verification Test with Barfield Pitot/Static Tester DPS450:

Procedure is given for the left side and is the same for the right side unless noted.

Refer to [Fig. 501, Sheet 1](#)

- (1) Connect the WOW Box or AMC to the aircraft and make sure that the ECB's are collared. Refer to [SUBTASK AMM-34-10-00-071-921-001](#).
- (2) Set the WOW Box switches to WOnW.
- (3) Power up the aircraft by setting the SYS BATT and START BATT switches to ON and the BUS TIE switch to AUTO.

**CAUTION:** DO NOT OVER TIGHTEN HOSES. DAMAGE MAY OCCUR TO TEST EQUIPMENT. HOSES SHOULD BE SNUG.

**NOTE:** Refer to step (4) if using the Air Data Accessories Kit ; (Nav Aids PN ADA500945) or step (5) if using the Air Data Accessories Kit (NavAids P/N ADA500MD-945).

(4) Connect the Barfield Pitot/Static Tester DPS450 to the aircraft using the Air Data Accessories Kit ; (Nav Aids PN ADA500945) as follows:

- (a) Install the Pitot/Angle of Attack (AOA) Probe Adaptor (Nav Aids, APA94520-4-4-4) (7) with the label TOP facing up on the Pitot/AOA probe. If needed, lubricate with Pitot adaptor lubricating fluid (Part Number LF5050). Adjust the Pitot/AOA Probe Adaptor nozzles to align with the holes of the Pitot/AOA probe.

**NOTE:** No other lubricating fluid is allowed, possible malfunction of the equipment in flight is possible.

**NOTE:** When installing the pressure test adapters, make sure that the seal is good by applying a firm force to seat the adapter on the probe.

- (b) Connect the Pitot Test Hose Assembly (long hose) (3) to the Pt connection (2) on the Barfield Pitot/Static Tester DPS450. Connect the other end of the long hose (3) to the quick-connect cross (4) .
- (c) Connect the Pitot Test Hose Assembly (three short hoses) (5,6 and 8) to the quick-connect cross (4) . Connect the other ends of the three short hoses (5,6 and 8) to the upper, center and lower connections on the Pitot/AOA Probe Adaptor (7) .

**NOTE:** Make sure that the Pitot/AOA Probe Adaptor nozzles are still aligned with the holes on the Pitot/AOA probe.

- (d) Connect the Static Test Hose Assembly ; (Nav Aids PN E500-5160) (long hose) (12) to the Barfield Pitot/Static Tester DPS450 Ps connection. Connect the other

end of the long hose (12) to the quick-connect cross (11) . Connect the static short hose (9) to the top fitting of the Static Port Adaptor (Nav Aids, SS53515-4-4) (10) .

- (e) Connect the Static Port Adaptor (Nav Aids, SS53515-4-4) (10) to the left Static port with the connected fitting to the top port and finger tighten the screws to seat the seals over the Static ports.
- (5) Connect the Barfield Pitot/Static Tester DPS450 to the aircraft using the Air Data Accessories Kit (NavAids P/N ADA500MD-945) as follows:
- NOTE:** When installing the pressure test adapters, make sure that the seal is good by applying a firm force to seat the adapter on the probe.
- NOTE:** The P22201MD-4 adapter contains a built-in seal that covers the Pitot/AOA probe drain hole. If using the P22201-3 adapter, the drain hole must be covered with teflon or vinyl tape.
- NOTE:** The Pitot/AOA probes with a drain hole near the base of mast, must have the drain hole covered. Failure to do so will result in a failure of this test.
- (a) Connect the Pitot Test Hose Assembly (3) to the Pt connection (2) on the Barfield Pitot/Static Tester DPS450. DO NOT OVERTIGHTEN.
- (b) Connect the opposite end of the hose to the NAV Aids P22201MD-4 adapter.
- (c) Install the NAV Aids P22201MD-4 adapter to the Pitot/AOA Probe. Make sure that the internal seal of the adapter covers the pitot probe drain hole. If using the P22201-3 adapter, make sure that the pitot probe drain hole is covered with tape. If needed, lubricate with Pitot adaptor lubricating fluid (Part Number LF5050).
- NOTE:** No other lubricating fluid is permitted. Malfunction of the equipment in flight is possible.
- (d) Connect the Static Port Adaptor (Nav Aids, SS53515-4-4) (10) to the left static port and finger tighten the screws to seat the seals over the static ports.
- (e) Connect the Static Test Hose Assembly ; (Nav Aids PN E500-5160) (long hose) (12) to the Barfield Pitot/Static Tester DPS450 Ps connection (1) .
- (f) Connect the other end of the hose (9) to the top fitting of the Static Port Adaptor (Nav Aids, SS53515-4-4) (10) .
- (6) Use tape to seal the opposite-side static port.
- NOTE:** Make sure to select a tape that does not leave any adhesive residue on the Static port when the test is complete.
- (7) Select WOffW on the WOW test box.
- (8) Set the transponder to STBY on the PFD.
- (9) If required, set both the left and right PFD baro to 29.92 by using the BARO SET knob on the ACP.
- Make sure that the baro setting matches on the left and right PFD and the optional Standby Display Unit (SDU) (if installed).
- (10) Turn on the Barfield Pitot/Static Tester DPS450.

- (11) Set the Barfield Pitot/Static Tester DPS450 static pressure to 40,613 feet and set the airspeed to 159.2 knots as follows:
  - (a) Press ALT Ps to select the ALT control aim, enter 40613 and press ENTER. Press SPEED Qc, enter 159.2 and press ENTER. Wait for at least a 15 second stabilization period after the altitude and airspeed achieve these new air data parameter set point values to continue.
- (12) Record the left PFD altimeter and airspeed.
  - Expected results are 41,000 ± 40 feet, 160 ± 2.5 knots, and 0.575 ± 0.008 Mach.
- (13) Set the Barfield Pitot/Static Tester DPS450 static pressure to 29,698 feet and increase the airspeed to 199.3 knots as follows:
  - (a) Press ALT Ps to select the ALT control aim, enter 29698 and press Enter. Press SPEED Qc, enter 199.3 and press ENTER. Wait for at least a 15 second stabilization period after the altitude and airspeed achieve these new air data parameter set point values to continue.
- (14) Record the left PFD altitude and airspeed.
  - Expected results are 30,000 ± 40 feet, 200 ± 2.7 knots and 0.557 ± 0.006 Mach.
- (15) Set the Barfield Pitot/Static Tester DPS450 static pressure to 19,706 feet and increase the airspeed to 237.6 knots as follows:
  - (a) Press ALT Ps to select the ALT control aim, enter 19706 and press Enter. Press SPEED Qc, enter 237.6 and press ENTER. Wait for at least a 15 second stabilization period after the altitude and airspeed achieve these new air data parameter set point values to continue.
- (16) Record the left PFD altitude and airspeed.
  - Expected results are 20,000± 40 feet, 240 ± 3 knots and 0.535 ± 0.006 Mach.
- (17) Set the Barfield Pitot/Static Tester DPS450 static pressure to 9,872 feet set the airspeed to 195.9 knots as follows:
  - (a) Press ALT Ps to select the ALT control aim, enter 9872" and press Enter. Press SPEED Qc, enter 195.9 and press Enter. Wait for at least a 15 second stabilization period after the altitude and airspeed achieve these new air data parameter set point values to continue.
- (18) Record the left PFD altitude and airspeed.
  - Expected results are 10,000± 33 feet and 200 ± 2.7 knots.
- (19) Set the Barfield Pitot/Static Tester DPS450 static pressure to 6,008 feet and set the airspeed to 66.1 knots as follows:
  - (a) Press ALT Ps to select the ALT control aim, enter 6008 and press Enter. Press SPEED Qc, enter 66.1 and press Enter. Wait for at least a 15 second stabilization period after the altitude and airspeed achieve these new air data parameter set point values to continue.
- (20) Record the left PFD altimeter and airspeed.
  - Expected results are 6,000 ± 25 feet and 65 ± 2 knots.
- (21) Press GROUND to go to atmospheric pressure. Press F1 to select Yes to confirm.

- 
- (a) If the Barfield Pitot/Static Tester DPS450 is not in CONTROL MODE, press LEAK MEASURE/CONTROL.
  - (b) After the Barfield Pitot/Static Tester DPS450 displays shows SAFE AT GROUND prompt, power off the Barfield Pitot/Static Tester DPS450.
- (22) Select WOnW on the WOW test box.
  - (23) Make sure that all of the Pitot and Static heat ECB's are collared.
  - (24) If no further maintenance is required, remove all of the Nav Aids test equipment from the aircraft. Stow all air data equipment and Barfield Pitot/Static Tester DPS450. Also, refer to [SUBTASK AMM-34-10-00-071-921-002](#).
- B. Pitot and Static Verification Test with the Barfield Pitot/Static Tester DPS500:  
Procedure is given for the left side and is the same for the right side unless specified.
- (1) Connect the WOW Box or AMC to the aircraft and make sure that the ECB's are collared. Refer to [SUBTASK AMM-34-10-00-071-921-001](#).
  - (2) Set the WOW Box switches to WOnW.
  - (3) Power up the aircraft by setting the SYS BATT and START BATT switches to ON and the BUS TIE switch to AUTO.

**CAUTION:** DO NOT OVER TIGHTEN HOSES. DAMAGE MAY OCCUR TO TEST EQUIPMENT. HOSES SHOULD BE SNUG.

**NOTE:** Refer to step (4) if using the Air Data Accessories Kit ; (Nav Aids PN ADA500945) or step (5) if using the Air Data Accessories Kit (NavAids P/N ADA500MD-945) - un.

- (4) Connect the Barfield Pitot/Static Tester DPS500 to the aircraft using the Air Data Accessories Kit ; (Nav Aids PN ADA500945) as follows:
  - (a) Install the Pitot/Angle of Attack (AOA) Probe Adaptor (Nav Aids, APA94520-4-4-4) (7) with the label TOP facing up on the Pitot/AOA probe. If needed, lubricate with Pitot adaptor lubricating fluid (Part Number LF5050). Adjust the Pitot/AOA Probe Adaptor nozzles to align with the holes of the Pitot/AOA probe.

**NOTE:** No other lubricating fluid is permitted. Malfunction of the equipment in flight is possible.

**NOTE:** When installing the pressure test adapters, make sure that the seal is good by applying a firm force to seat the adapter on the probe.
  - (b) Connect the Pitot Test Hose Assembly (long hose) (3) to the Pt connection (2) on the Barfield Pitot/Static Tester DPS500. Connect the other end of the long hose (3) to the quick-connect cross (4) .
  - (c) Connect the Pitot Test Hose Assembly (three short hoses) (5,6 and 8) to the quick-connect cross (4) . Connect the other ends of the three short hoses (5,6 and 8) to the upper, center and lower connections on the Pitot/AOA Probe Adaptor (7) .

**NOTE:** Make sure that the Pitot/AOA Probe Adaptor nozzles are still aligned with the holes on the Pitot/AOA probe.

(d) Connect the Static Test Hose Assembly ; (Nav Aids PN E500-5160) (long hose) (12) to the Barfield Pitot/Static Tester DPS500 Ps connection. Connect other end of long hose (12) to the quick-connect cross (11) . Connect the static short hose (9) to the top fitting of the Static Port Adaptor (Nav Aids, SS53515-4-4) (10) .

(e) Connect the Static Port Adaptor (Nav Aids, SS53515-4-4) (10) to the left static port with the connected fitting to the top port and finger tighten the screws to seat the seals over the static ports.

**NOTE:** The right static upper port can be tested from the left static lower port by connecting the short hose to the lower port connection on the Static Port Adaptor. The aircraft's left lower port is connected to the right upper port and the left upper port is connected to the right lower port by aircraft design. Refer to [Fig. 503, Sheet 1](#)

(5) Connect the Barfield Pitot/Static Tester DPS500 to the aircraft using the Air Data Accessories Kit (NavAids P/N ADA500MD-945) as follows:

**NOTE:** When installing the pressure test adapters, make sure that the seal is good by applying a firm force to seat the adapter on the probe.

**NOTE:** The P22201MD-4 adapter contains a built-in seal that covers the Pitot/AOA probe drain hole. If using the P22201-3 adapter, the drain hole must be covered with teflon or vinyl tape.

**NOTE:** The Pitot/AOA probes with a drain hole near the base of mast, must have the drain hole covered. Failure to do so will result in a failure of this test.

(a) Connect the Pitot Test Hose Assembly (3) to the Pt connection (2) on the Barfield Pitot/Static Tester DPS500. DO NOT OVERTIGHTEN.

(b) Connect the opposite end of the hose to the NAV Aids P22201MD-4 adapter.

(c) Install the NAV Aids P22201MD-4 adapter to the Pitot/AOA Probe. Make sure that the internal seal of the adapter covers the pitot probe drain hole. If using the P22201-3 adapter, make sure that the pitot probe drain hole is covered with tape. If needed, lubricate with Pitot adaptor lubricating fluid (Part Number LF5050)..

**NOTE:** No other lubricating fluid is permitted. Malfunction of the equipment in flight is possible.

(d) Connect the Static Test Hose Assembly ; (Nav Aids PN E500-5160) (12) to the Barfield Pitot/Static Tester DPS500 Ps connection (1) .

(e) Connect the other end of the Static Test Hose Assembly (12) to the top fitting of the Static Port Adaptor (Nav Aids, SS53515-4-4) (10) .

(f) Connect the Static Port Adaptor (Nav Aids, SS53515-4-4) (10) to the left Static port with the connected fitting to the top port and finger tighten the screws to seat the seals over the Static ports.

(6) Use tape to seal the opposite-side static port.

**NOTE:** Make sure to select a tape that does not leave any adhesive residue on the static port when the test is complete.

(7) Select WOffW on the WOW test box.

(8) Set the transponder to STBY on the PFD.

- (9) Set both the left and right PFD Baro to 29.92 by using the BARO SET knob on the ACP.
  - Make sure the baro setting matches on the left and right PFD.
- (10) Power on the Barfield Pitot/Static Tester DPS500 by selecting OPERATE and PUMP switches to ON. Wait for the Barfield Pitot/Static Tester DPS500 to Confirm Settings.
  - After a successful self-test sequence, the system changes to the Warm Up mode.
- (11) Set the Barfield Pitot/Static Tester DPS500 static pressure to 40,613 feet and set the airspeed to 159.2 knots as follows:
  - (a) Press ALT Ps to select the ALT control aim, enter 40613 and press Enter. Press SPEED Qc, enter 159.2 and press ENTER. Wait for at least a 15 second stabilization period after the altitude and airspeed achieve these new air data parameter set point values to continue.
- (12) Record the left PFD altitude and airspeed.
  - Expected results are 41,000 ± 40 feet, 160 ± 2.5 knots and 0.575 ± 0.008 Mach.
- (13) Set the Barfield Pitot/Static Tester DPS500 static pressure to 29,698 feet and increase airspeed to 199.3 knots as follows:
  - (a) Press ALT Ps to select the ALT control aim, enter 29698 and press Enter. Press SPEED Qc, enter 199.3 and press Enter. Wait for at least a 15 second stabilization period after the altitude and airspeed achieve these new air data parameter set point values to continue.
- (14) Record the left PFD altitude and airspeed.
  - Expected results are 30,000 ± 40 feet, 200 ± 2.7 knots, and 0.557 ± 0.006 Mach.
- (15) Set the Barfield Pitot/Static Tester DPS500 static pressure to 19,706 feet and increase airspeed to 237.6 knots as follows:
  - (a) Press ALT Ps to select the ALT control aim, enter 19706 and press Enter. Press SPEED Qc, enter 237.6 and press Enter. Wait for at least a 15 second stabilization period after the altitude and airspeed achieve these new air data parameter set point values to continue.
- (16) Record the left PFD altitude and airspeed.
  - Expected results are 20,000± 40 feet, 240 ± 3 knots, and 0.535 ± 0.006 Mach.
- (17) Set the Barfield Pitot/Static Tester DPS500 static pressure to 9,872 feet and set airspeed to 195.9 knots as follows:
  - (a) Press ALT Ps to select the ALT control aim, enter 9872 and press Enter. Press SPEED Qc, enter 195.9 and press Enter. Wait for at least a 15 second stabilization period after the altitude and airspeed achieve these new air data parameter set point values to continue.
- (18) Record the left PFD altitude and airspeed.
  - Expected results are 10,000± 33 feet and 200 ± 2.7 knots.
- (19) Set the Barfield Pitot/Static Tester DPS500 static pressure to 6,008 feet and set airspeed to 66.1 knots as follows:

- (a) Press ALT Ps to select the ALT control aim, enter 6008 and press Enter. Press SPEED Qc, enter 66.1 and press Enter. Wait for at least a 15 second stabilization period after the altitude and airspeed achieve these new air data parameter set point values to continue.
- (20) Record the left PFD altitude and airspeed.
  - Expected results are 6,000 ± 25 feet and 65 ± 2 knots.
- (21) Press GROUND to go to atmospheric pressure. Press F1 (Go to Ground).
  - (a) After the Barfield Pitot/Static Tester DPS500 displays shows SAFE AT GROUND prompt, press CLEAR/QUIT.
- (22) Select WOnW on the WOW test box.
- (23) Make sure that the Pitot and Static heat ECB's are collared.
- (24) If no further maintenance is required, remove all of the NAV Aids test equipment from the aircraft. Stow all air data equipment and the Barfield Pitot/Static Tester DPS500. Also, refer to [SUBTASK AMM-34-10-00-071-921-002](#).

## 9. **Standby Pitot/Static Probe Verification Test**

SUBTASK AMM-34-10-00-071-701-006

\*\*\* 000001-000262, 000262 and 000267 PRE MB 500-31-006

**NOTE:** If a Barfield Pitot/Static Tester DPS450 is used for this test complete paragraph A. If a Barfield Pitot/Static Tester DPS500 is used, go to paragraph B.

- A. Standby Pitot/Static Probe Verification Test with a Barfield Pitot/Static Tester DPS450:
  - (1) Connect the WOW Box or AMC to the aircraft and make sure that the ECB's are collared. Refer to [SUBTASK AMM-34-10-00-071-921-001](#).
  - (2) Set the WOW Box switches to WOnW.
  - (3) Power up the aircraft by setting the SYS BATT and START BATT switches to ON and the BUS TIE switch to AUTO.
  - (4) Select WOffW on the WOW test box.
  - (5) Set the transponder to STBY on the PFD.
  - (6) If required, set both the left and right PFD baro to 29.92 by using the BARO SET knob on the ACP.
    - Make sure the baro setting matches on the left and right PFD.
  - (7) Set the static pressure to 39,889 feet and set the airspeed to 197.0 Knots.
    - (a) Press ALT Ps to select the ALT control aim, enter 39889 and press ENTER. Press SPEED Qc and enter 197.0 then press ENTER. Wait for at least a 15 second stabilization period after the altitude and airspeed achieve these new air data parameter set point values to continue.
  - (8) Record the Pitot/Static probe Altitude and Airspeed from the MFD.
    - Expected Results: 40,000 ± 105 feet, 190 ± 2.7 knots, and 0.667 ± 0.011 Mach.

- 
- (9) Set the static pressure to 29,874 feet and set the airspeed to 247.1 Knots.
    - (a) Press ALT Ps to select the ALT control aim, enter 29874 and press ENTER. Press SPEED Qc and enter 247.1 then press ENTER. Wait for at least a 15 second stabilization period after the altitude and airspeed achieve these new air data parameter set point values to continue.
  - (10) Record the Standby Pitot/Static probe altitude and airspeed from the MFD.
    - Expected Results: 30000 ± 75 feet, 240 ± 2.7 knots, and 0.665 ± 0.011 Mach.
  - (11) Set the static pressure to 19,899 feet and increase airspeed to 247.5 Knots.
    - (a) Press ALT Ps to select the ALT control aim, enter 19899 and press ENTER. Press SPEED Qc and enter 247.5 then press ENTER. Wait for at least a 15 second stabilization period after the altitude and airspeed achieve these new air data parameter set point values to continue.
  - (12) Record the Standby Pitot/Static probe altitude and airspeed from the MFD.
    - Expected Results: 20,000 ± 50 feet, 245 ± 3 knots, and 0.546 ± 0.008 Mach.
  - (13) Set the static pressure to 9,998 feet and set the airspeed to 99.9 Knots.
    - (a) Press ALT Ps to select the ALT control aim, enter 9998 and press ENTER. Press SPEED Qc and enter 99.9 then press ENTER. Wait for at least a 15 second stabilization period after the altitude and airspeed achieve these new air data parameter set point values to continue.
  - (14) Record the Standby Pitot/Static probe altitude and airspeed from the MFD.
    - Expected Results: 10,000 ± 33 feet and 100 ± 3 knots.
  - (15) Set the static pressure to 5,999 feet and set the airspeed to 64.9 Knots.
    - (a) Press ALT Ps to select the ALT control aim, enter 5999 and press ENTER. Press SPEED Qc and enter 64.9 then press ENTER. Wait for at least a 15 second stabilization period after the altitude and airspeed achieve these new air data parameter set point values to continue.
  - (16) Record the Standby Pitot/Static probe altitude and airspeed from the MFD.
    - Expected results are 6,000 ± 30 feet and 65 ± 4 knots.
  - (17) Press GROUND to go to atmospheric pressure. Press F1 to select Yes to confirm.
    - (a) If the Barfield Pitot/Static Tester DPS450 is not in CONTROL MODE, press LEAK MEASURE/CONTROL.
    - (b) After the Barfield Pitot/Static Tester DPS450 displays shows SAFE AT GROUND prompt, power off the Barfield Pitot/Static Tester DPS450.
  - (18) If no further maintenance is required, remove all of the Nav Aids test equipment from the aircraft. Stow all air data equipment and the Barfield Pitot/Static Tester DPS450. Also, refer to [SUBTASK AMM-34-10-00-071-921-002](#).
- B. Standby Pitot/Static Probe Verification Test with a Barfield Pitot/Static Tester DPS500:
- (1) Connect the WOW Box or AMC to the aircraft and make sure that the ECBs are collared. Refer to [SUBTASK AMM-34-10-00-071-921-001](#).

- (2) Set the WOW Box switches to WOnW.
- (3) Power up the aircraft by setting the SYS BATT and START BATT switches to ON and the BUS TIE switch to AUTO.
- (4) Select WOffW on the WOW test box.
- (5) Set the transponder to STBY on the PFD.
- (6) If required, set both the left and right PFD baro to 29.92 by using the BARO SET knob on the ACP.
  - Make sure that the baro setting matches on the left PFD, right PFD and MFD.
- (7) Set the static pressure to 39,889 feet and set the airspeed to 197.0 Knots.
  - (a) Press ALT Ps to select the ALT control aim, enter 39889 and press ENTER. Press SPEED Qc and enter 197.0 then press ENTER. Wait for at least a 15 second stabilization period after the altitude and airspeed achieve these new air data parameter set point values to continue.
- (8) Record the Standby Pitot/Static probe altitude and airspeed from the MFD.
  - Expected Results: 40,000 ± 105 feet, 190 ± 2.7 knots, and 0.667 ± 0.011 Mach.
- (9) Set the static pressure to 29,874 feet and set the airspeed to 247.1 Knots.
  - (a) Press ALT Ps to select the ALT control aim, enter 29874 and press ENTER. Press SPEED Qc and enter 247.1 then press ENTER. Wait for at least a 15 second stabilization period after the altitude and airspeed achieve these new air data parameter set point values to continue.
- (10) Record the Standby Pitot/Static probe altitude and airspeed from the MFD.
  - Expected Results: 30,000 ± 75 feet 240 ± 2.7 knots 0.665 ± 0.011 Mach.
- (11) Set the static pressure to 19,899 feet and increase airspeed to 247.5 Knots.
  - (a) Press ALT Ps to select the ALT control aim, enter 19899 and press ENTER. Press SPEED Qc and enter 247.5 then press ENTER. Wait for at least a 15 second stabilization period after the altitude and airspeed achieve these new air data parameter set point values to continue.
- (12) Record the Standby Pitot/Static probe altitude and airspeed from the MFD.
  - Expected Results: 20,000 ± 50 feet, 245 ± 3 knots, and 0.546 ± 0.008 Mach.
- (13) Set the static pressure to 9,998 feet and set the airspeed to 99.9 Knots.
  - (a) Press ALT Ps to select the ALT control aim, enter 9998 and press ENTER. Press SPEED Qc and enter 99.9 then press ENTER. Wait for at least a 15 second stabilization period after the altitude and airspeed achieve these new air data parameter set point values to continue.
- (14) Record the Standby Pitot/Static probe altitude and airspeed from the MFD.
  - Expected Results: 10,000 ± 33 feet 100 ± 3 knots.
- (15) Set the static pressure to 5,999 feet and set the airspeed to 64.9 Knots.
  - (a) Press ALT Ps to select the ALT control aim, enter 5999 and press ENTER. Press SPEED Qc and enter 64.9 then press ENTER. Wait for at least a 15 second

stabilization period after the altitude and airspeed achieve these new air data parameter set point values to continue.

- (16) Record the Standby Pitot/Static probe altitude and airspeed from the MFD.
  - Expected Results: 6000 ± 30 feet and 65 ± 4 knots.
- (17) Press GROUND to go to atmospheric pressure. Press F1 to select Yes to confirm.
  - (a) If the Barfield Pitot/Static Tester DPS500 is not in CONTROL MODE, press LEAK MEASURE/CONTROL.
  - (b) After the Barfield Pitot/Static Tester DPS500 displays shows SAFE AT GROUND prompt, power off the Barfield Pitot/Static Tester DPS500.
- (18) If no further maintenance is required, remove all of the Nav Aids test equipment from the aircraft. Stow all air data equipment and the Barfield Pitot/Static Tester DPS500. Also, refer to [SUBTASK AMM-34-10-00-071-921-002](#).

## **10. Standby Pitot/Static Probe Verification Test - Standby Display Unit (SDU)**

SUBTASK AMM-34-10-00-071-701-007

\* \* \* 000001-000262, 000262 and 000267 POST MB 500-31-006

NOTE: If a Barfield Pitot/Static Tester DPS450 is used for this test complete paragraph A. If a Barfield Pitot/Static Tester DPS500 is used, go to paragraph B.

- A. Standby Pitot/Static Probe Verification Test with a Barfield Pitot/Static Tester DPS450:
  - (1) Connect the WOW Box to the aircraft and make sure that the ECBs are collared. Refer to [SUBTASK AMM-34-10-00-071-921-001](#).
  - (2) Set the WOW Box switches to WOnW.
  - (3) Power up the aircraft by setting the SYS BATT and START BATT switches to ON and the BUS TIE switch to AUTO.
  - (4) Select WOffW on the WOW test box.
  - (5) Set the transponder to STBY on the PFD.
  - (6) If required, set both the left and right SDU baro to 29.92 by press and HOLD the MENU button until the Baro reads 29.92 (or use ARROWS to adjust the Baro reading)..

NOTE: Right SDU is optional.

    - Make sure the baro setting matches on the left and right SDU.
  - (7) Set the static pressure to 39,889 feet and set the airspeed to 197.0 Knots.
    - (a) Press ALT Ps to select the ALT control aim, enter 39889 and press ENTER. Press SPEED Qc and enter 197.0 then press ENTER. Wait for at least a 15 second stabilization period after the altitude and airspeed achieve these new air data parameter set point values to continue.
  - (8) Record the Pitot/Static probe Altitude and Airspeed from the SDU.
    - Expected Results: 40,000 ± 105 feet and 190 ± 2.7 knots.

- (9) Set the static pressure to 29,874 feet and set the airspeed to 247.1 Knots.
    - (a) Press ALT Ps to select the ALT control aim, enter 29874 and press ENTER. Press SPEED Qc and enter 247.1 then press ENTER. Wait for at least a 15 second stabilization period after the altitude and airspeed achieve these new air data parameter set point values to continue.
  - (10) Record the Standby Pitot/Static probe altitude and airspeed from the SDU.
    - Expected Results: 30000 ± 75 feet and 240 ± 2.7 knots.
  - (11) Set the static pressure to 19,899 feet and increase airspeed to 247.5 Knots.
    - (a) Press ALT Ps to select the ALT control aim, enter 19899 and press ENTER. Press SPEED Qc and enter 247.5 then press ENTER. Wait for at least a 15 second stabilization period after the altitude and airspeed achieve these new air data parameter set point values to continue.
  - (12) Record the Standby Pitot/Static probe altitude and airspeed from the SDU.
    - Expected Results: 20,000 ± 50 feet and 245 ± 3 knots.
  - (13) Set the static pressure to 9,998 feet and set the airspeed to 99.9 Knots.
    - (a) Press ALT Ps to select the ALT control aim, enter 9998 and press ENTER. Press SPEED Qc and enter 99.9 then press ENTER. Wait for at least a 15 second stabilization period after the altitude and airspeed achieve these new air data parameter set point values to continue.
  - (14) Record the Standby Pitot/Static probe altitude and airspeed from the SDU.
    - Expected Results: 10,000 ± 33 feet and 100 ± 3 knots.
  - (15) Set the static pressure to 5,999 feet and set the airspeed to 64.9 Knots.
    - (a) Press ALT Ps to select the ALT control aim, enter 5999 and press ENTER. Press SPEED Qc and enter 64.9 then press ENTER. Wait for at least a 15 second stabilization period after the altitude and airspeed achieve these new air data parameter set point values to continue.
  - (16) Record the Standby Pitot/Static probe altitude and airspeed from the SDU.
    - Expected results are 6,000 ± 30 feet and 65 ± 4 knots.
  - (17) Press GROUND to go to atmospheric pressure. Press F1 to select Yes to confirm.
    - (a) If the Barfield Pitot/Static Tester DPS450 is not in CONTROL MODE, press LEAK MEASURE/CONTROL.
    - (b) After the Barfield Pitot/Static Tester DPS450 displays shows SAFE AT GROUND prompt, power off the Barfield Pitot/Static Tester DPS450.
  - (18) If no further maintenance is required, remove all of the Nav Aids test equipment from the aircraft. Stow all air data equipment and the Barfield Pitot/Static Tester DPS450. Also, refer to [SUBTASK AMM-34-10-00-071-921-002](#).
- B. Standby Pitot/Static Probe Verification Test with a Barfield Pitot/Static Tester DPS500:
- (1) Connect the WOW Box or AMC to the aircraft and make sure that the ECBs are collared. Refer to [SUBTASK AMM-34-10-00-071-921-001](#).

- (2) Set the WOW Box switches to WOnW.
- (3) Power up the aircraft by setting the SYS BATT and START BATT switches to ON and the BUS TIE switch to AUTO.
- (4) Select WOffW on the WOW test box.
- (5) Set the transponder to STBY on the PFD.
- (6) If required, set both the left and right SDU baro to 29.92 by press and HOLD the MENU button until the Baro reads 29.92 (or use ARROWS to adjust the Baro reading)..

NOTE: Right SDU is optional.

- Make sure the baro setting matches on the left and right SDU.
- (7) Set the static pressure to 39,889 feet and set the airspeed to 197.0 Knots.
    - (a) Press ALT Ps to select the ALT control aim, enter 39889 and press ENTER. Press SPEED Qc and enter 197.0 then press ENTER. Wait for at least a 15 second stabilization period after the altitude and airspeed achieve these new air data parameter set point values to continue.
  - (8) Record the Standby Pitot/Static probe altitude and airspeed from the SDU.
    - Expected Results: 40,000 ± 105 feet and 190 ± 2.7 knots.
  - (9) Set the static pressure to 29,874 feet and set the airspeed to 247.1 Knots.
    - (a) Press ALT Ps to select the ALT control aim, enter 29874 and press ENTER. Press SPEED Qc and enter 247.1 then press ENTER. Wait for at least a 15 second stabilization period after the altitude and airspeed achieve these new air data parameter set point values to continue.
  - (10) Record the Standby Pitot/Static probe altitude and airspeed from the SDU.
    - Expected Results: 30,000 ± 75 feet and 240 ± 2.7 knots.
  - (11) Set the static pressure to 19,899 feet and increase airspeed to 247.5 Knots.
    - (a) Press ALT Ps to select the ALT control aim, enter 19899 and press ENTER. Press SPEED Qc and enter 247.5 then press ENTER. Wait for at least a 15 second stabilization period after the altitude and airspeed achieve these new air data parameter set point values to continue.
  - (12) Record the Standby Pitot/Static probe altitude and airspeed from the SDU.
    - Expected Results: 20,000 ± 50 feet and 245 ± 3 knots.
  - (13) Set the static pressure to 9,998 feet and set the airspeed to 99.9 Knots.
    - (a) Press ALT Ps to select the ALT control aim, enter 9998 and press ENTER. Press SPEED Qc and enter 99.9 then press ENTER. Wait for at least a 15 second stabilization period after the altitude and airspeed achieve these new air data parameter set point values to continue.
  - (14) Record the Standby Pitot/Static probe altitude and airspeed from the SDU.
    - Expected Results: 10,000 ± 33 feet and 100 ± 3 knots.
  - (15) Set the static pressure to 5,999 feet and set the airspeed to 64.9 Knots.

- (a) Press ALT Ps to select the ALT control aim, enter 5999 and press ENTER. Press SPEED Qc and enter 64.9 then press ENTER. Wait for at least a 15 second stabilization period after the altitude and airspeed achieve these new air data parameter set point values to continue.
- (16) Record the Standby Pitot/Static probe altitude and airspeed from the SDU.
  - Expected Results: 6000 ± 30 feet and 65 ± 4 knots.
- (17) Press GROUND to go to atmospheric pressure. Press F1 to select Yes to confirm.
  - (a) If the Barfield Pitot/Static Tester DPS500 is not in CONTROL MODE, press LEAK MEASURE/CONTROL.
  - (b) After the Barfield Pitot/Static Tester DPS500 displays shows SAFE AT GROUND prompt, power off the Barfield Pitot/Static Tester DPS500.
- (18) If no further maintenance is required, remove all of the Nav Aids test equipment from the aircraft. Stow all air data equipment and the Barfield Pitot/Static Tester DPS500. Also, refer to [SUBTASK AMM-34-10-00-071-921-002](#).

## **11. Outside Air Temperature Test**

SUBTASK AMM-34-10-00-071-701-008

\*\*\* ALL

- A. Do an Outside Air Temperature Test as follows:
  - (1) Power up the aircraft by setting the SYS BATT and START BATT switches to ON and the BUS TIE switch to AUTO.
  - (2) Scroll to the ICE synoptic page on the MFD by using the lower left/right softkey.
  - (3) Expected results are that left and right OATs are within ± 5°C of the measured outside temperature. Left and Right PFDs are within ± 2°C of MFD OAT temperature.
  - (4) Power down the aircraft by setting the SYS BATT and START BATT switches to OFF and the BUS TIE switch to OPEN.

## **12. Job Close-Up**

SUBTASK AMM-34-10-00-071-921-002

\*\*\* ALL

- A. If no other tests are required with the Weight On Wheels (WOW) box or Aircraft Maintenance Computer (AMC), select WOnW.
  - (1) Re-set the following ECBs:
    - ECB - WEATHER RADAR (L FWD Bus)
    - ECB - DEICE MANIFOLD HTR (R AFT Bus)
    - ECB - L PITOT HEAT (L FWD Bus) or ECB - L PITOT HEAT (BATT Bus)
    - ECB - R PITOT HEAT (R FWD Bus)
    - ECB - L STATIC HEAT (BATT Bus)

- ECB - L STATIC HEAT (R FWD Bus)
  - ECB - R STATIC HEAT (R FWD Bus)
  - ECB - R STATIC HEAT (L FWD Bus)
  - ECB - STBY PITOT HEAT (BATT Bus) or ECB - STBY PITOT HEAT (L FWD)
  - ECB - L WINDSHIELD HEAT (L AFT Bus)
  - ECB - R WINDSHIELD HEAT (R AFT Bus)
- (2) Power down the aircraft by setting the SYS BATT and START BATT switches to OFF and the BUS TIE switch to OPEN.
- (3) Disconnect WOW Box or AMC from aircraft. Refer to AMM-20-00-04-051-801 – Weight On Wheels (WOW) Box - Connect/Disconnect.
- B. Remove the external power from the aircraft. Refer to [AMM-24-40-00-051-801 – External Power - Maintenance Practices](#).
- C. Remove all tools, equipment and unwanted material from work area.
- D. If all other maintenance is complete, return aircraft to service. Refer to [AMM-20-00-02-051-801 – Return To Service \(After Maintenance\)](#).

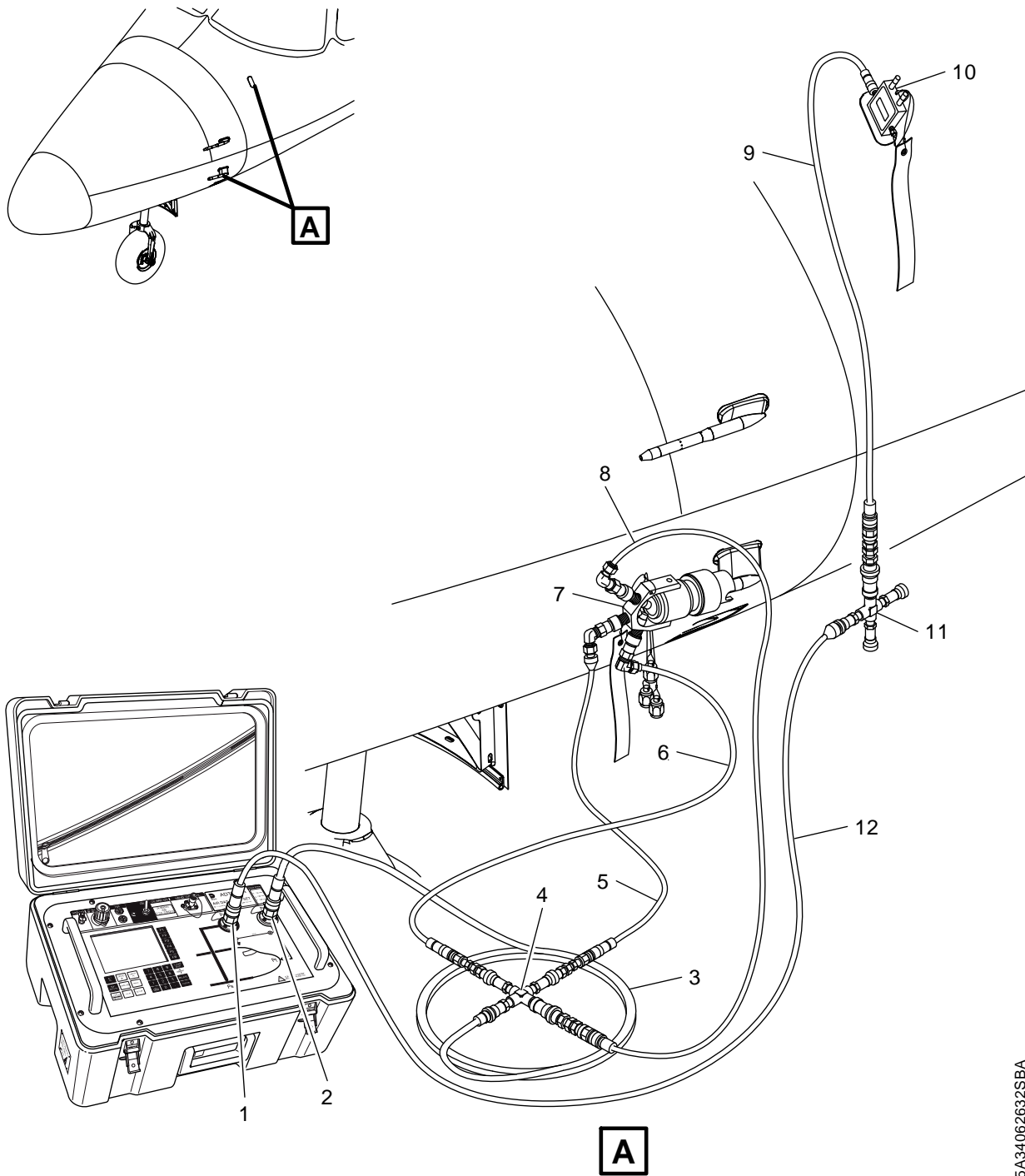

**Left Pitot/Static Hose Configuration (Three Port Adapter)  
Figure 501 (Sheet 1 of 1)**

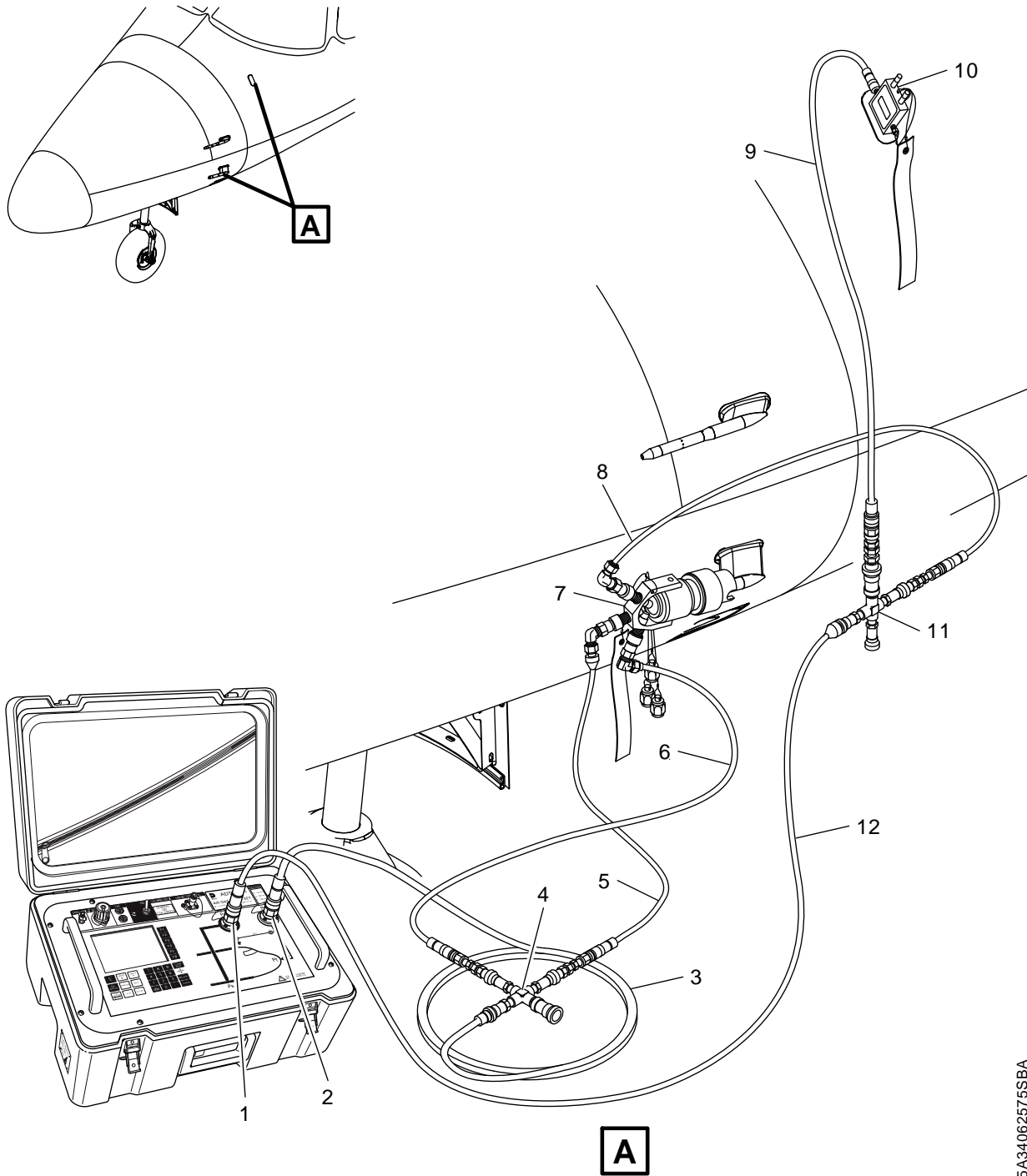

5A34062575SBA

**Left Angle of Attack Hose Configuration  
Figure 502 (Sheet 1 of 1)**

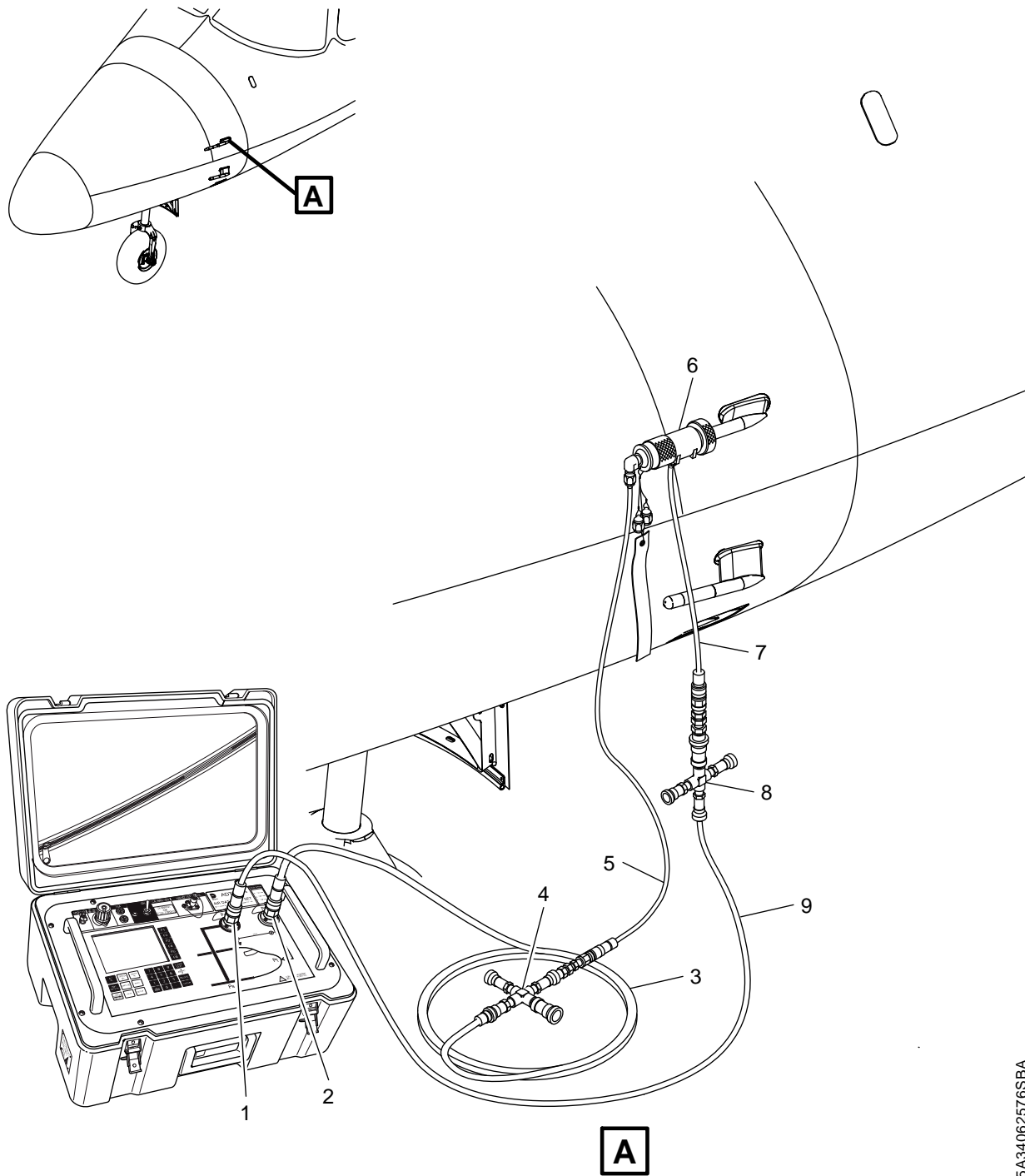

5A34062576SBA

**Standby Pitot/Static Test Adaptor Connections**  
**Figure 503 (Sheet 1 of 1)**

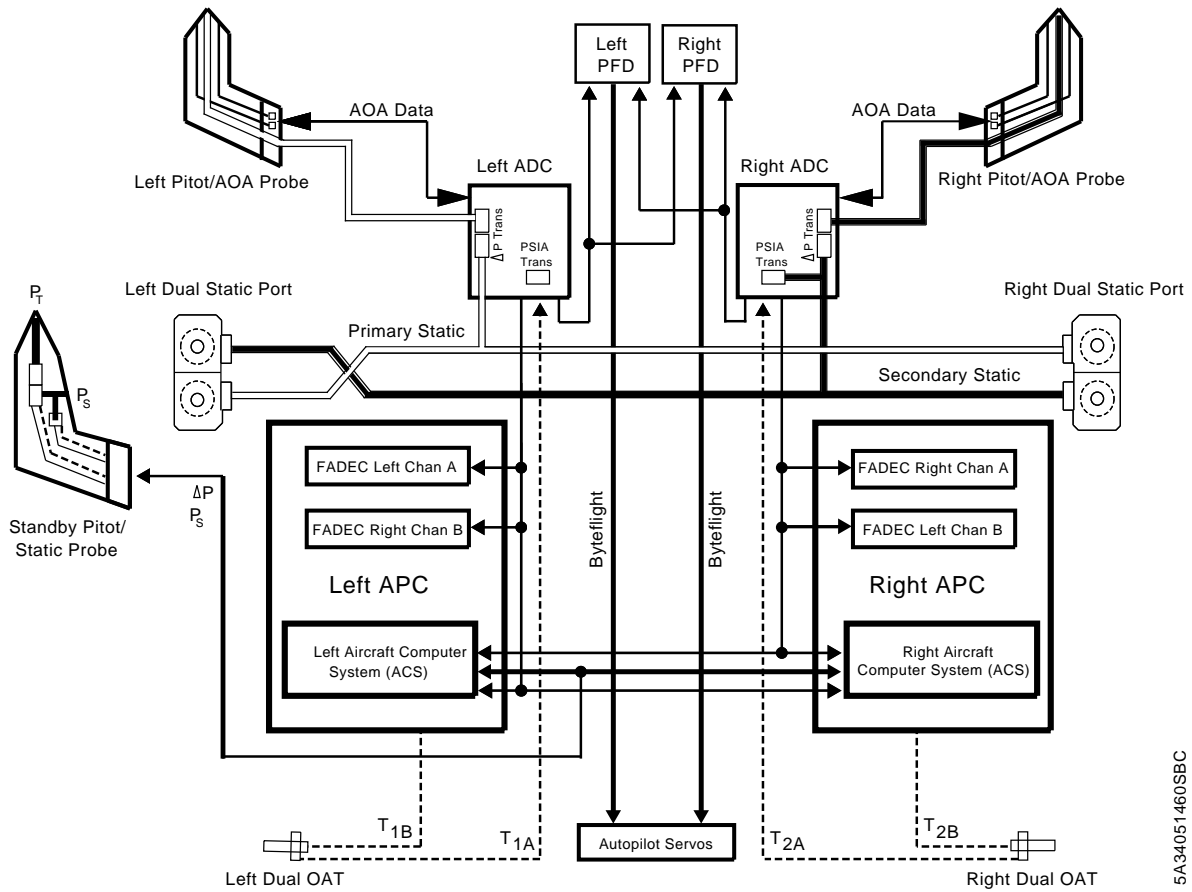

5A34051460SEC

**Air Data System Block Diagram**  
**Figure 504 (Sheet 1 of 1)**

---

## **PITOT/AOA PROBES - REMOVAL**

AMM-34-10-10-001-C-801

### **1. General**

- A. This task gives the procedures to remove the Pitot/Angle of Attack (AOA) probes.
- B. There are two Pitot/AOA probes on the fuselage, forward of the cockpit. Access procedures for the right Pitot/AOA probe are given in Job Setup.

NOTE: In the event the grounding jumper needs to be replaced, the entire probe must be removed.

NOTE: In the event that the auxiliary heater needs to be replaced, the entire probe must be removed.

### **2. Job Set-Up**

SUBTASK AMM-34-10-10-001-C-921-001

- A. Make aircraft safe for maintenance. Refer to [AMM-20-00-01-051-801 – Make Safe For Maintenance](#).
- B. To gain access to remove the left Pitot/AOA probe remove the access panel that follows:
  - 211 CT - Nose Access Panel
- C. To gain access to remove the right Pitot/AOA, use the Air Conditioning controls to open the VCS doors, as follows:
  - (1) Connect AMC to right armrest USB port. Refer to [Fig. 402](#).
  - (2) On the MFD ENVIR page, establish the following conditions:
    - AIR COND: AUTO
    - AFT Fan: AUTO
    - FWD Fan: AUTO
    - Cockpit Temp: MAX COOL
    - Cabin Temp: MAX COOL
  - (3) Make sure the Forward and Aft VCS doors have fully opened. Refer to [AMM-21-00-00-071-801 – Air Conditioning - Adjustment/Test](#), . Refer to [Fig. 403](#).
- D. Remove power from the aircraft.

CAUTION: AFT VCS DOOR MUST BE DISABLED TO PREVENT PERSONAL INJURY AND DAMAGE TO EQUIPMENT IF AIRCRAFT POWER IS INADVERTENTLY APPLIED.

- (1) Once electrical power is removed, disconnect the electrical connector on the aft VCS door actuator.

### 3. Procedure

SUBTASK AMM-34-10-10-001-C-011-001

(Refer to [Fig. 401](#).)

- A. Disconnect electrical connector (17) from aircraft wiring harness.
  - B. Remove jam nut (15) from electrical connector (17) and remove electrical connector from bracket (16) by removing .
  - C. Disconnect electrical connector (2) from Pitot/AOA probe (4) .
  - D. Disconnect Pitot tube assembly (3) from Pitot/AOA probe (4) .
  - E. Disconnect Pitot/AOA Auxiliary Heater electrical connector (17) from aircraft harness.
  - F. Remove jam nut (15) from Pitot/AOA Auxiliary Heater electrical connector (17) and remove connector (17) from bracket (16) .
  - G. For the LH Pitot/AOA probe ([Fig. 401, Sheet 2](#)), remove the self locking nut (8) , lock washer (9) , flat washer (10) , grounding jumper (7) , and the hex head screw (11) from hole (12) in the aircraft structure.
  - H. For the RH Pitot/AOA probe ([Fig. 401, Sheet 3](#)), remove the self locking nut (8) , flat washer (10) , grounding jumper (7) , and the hex head screw (11) from hole (12) in the aircraft structure.
  - I. Remove five screws (5) that attach Pitot/AOA probe (4) to structure (1) .
  - J. Remove Pitot/AOA probe (4) with grounding jumper (7) attached and gasket (6) from aircraft.
- NOTE:** Do not remove grounding jumper from probe unless it needs to be replaced.
- K. If required for the LH Pitot/AOA probe ([Fig. 401, Sheet 2](#)), remove the screw (14) , washer (13) , and grounding jumper (7) from the Pitot/AOA probe (4) .
  - L. If required for the RH Pitot/AOA probe ([Fig. 401, Sheet 3](#)), remove the screw (14) , washer (13) , and grounding jumper (7) from the Pitot/AOA probe (4) .

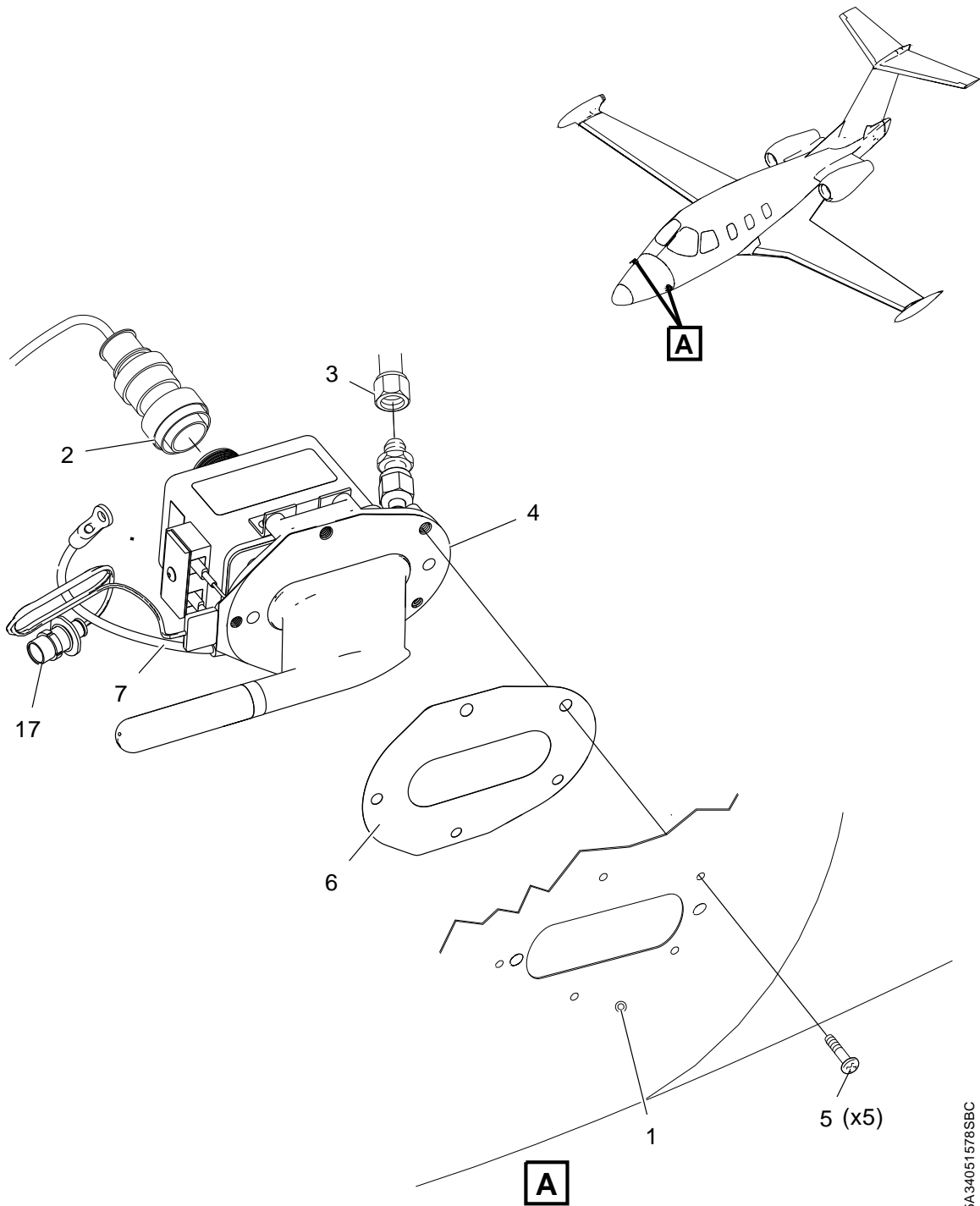

5A 34051578SBC

**Pitot/AOA Probes - Removal/Installation**  
**Figure 401 (Sheet 1 of 4)**

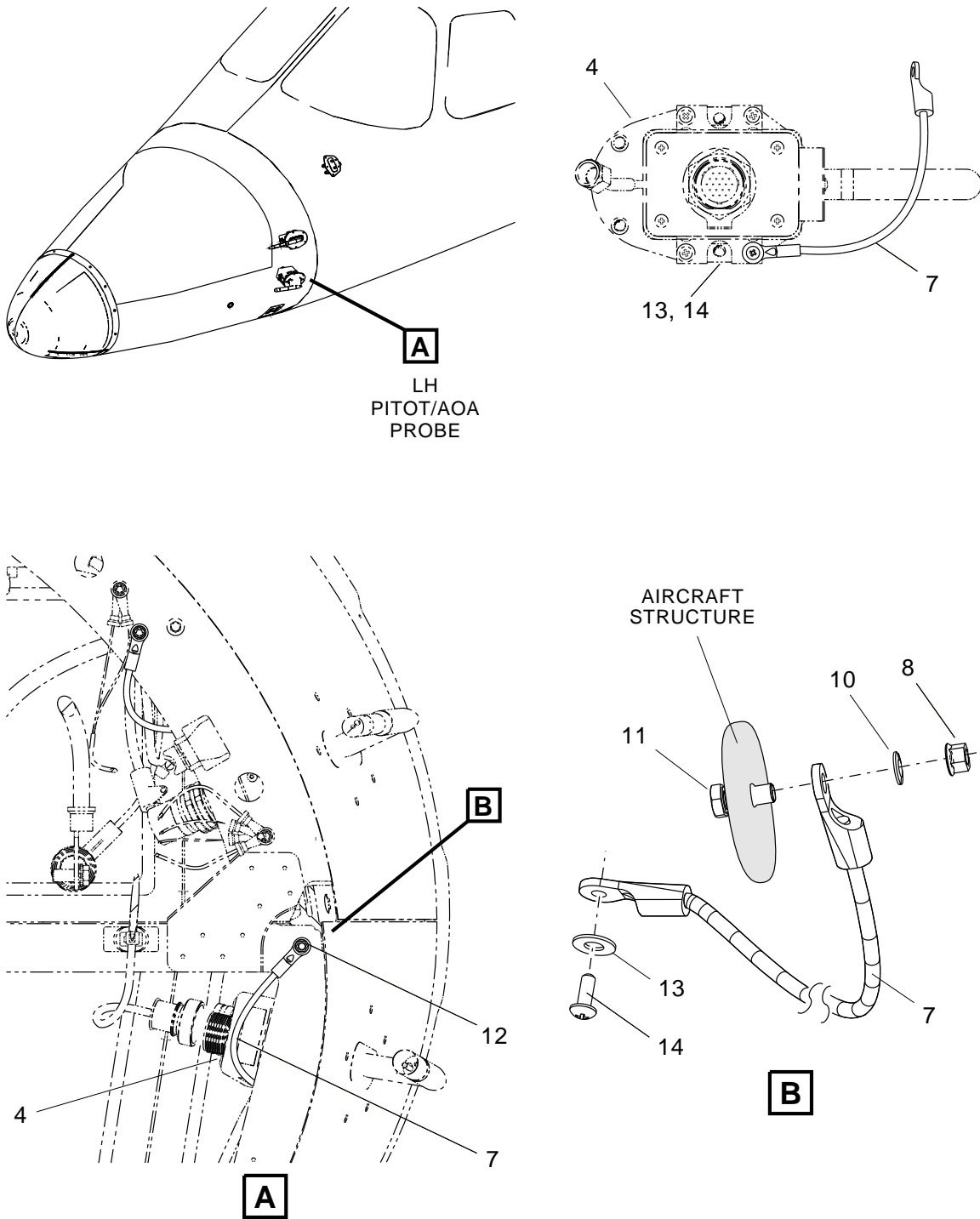

**Pitot/AOA Probes - Removal/Installation**  
**Figure 401 (Sheet 2 of 4)**

5141820A

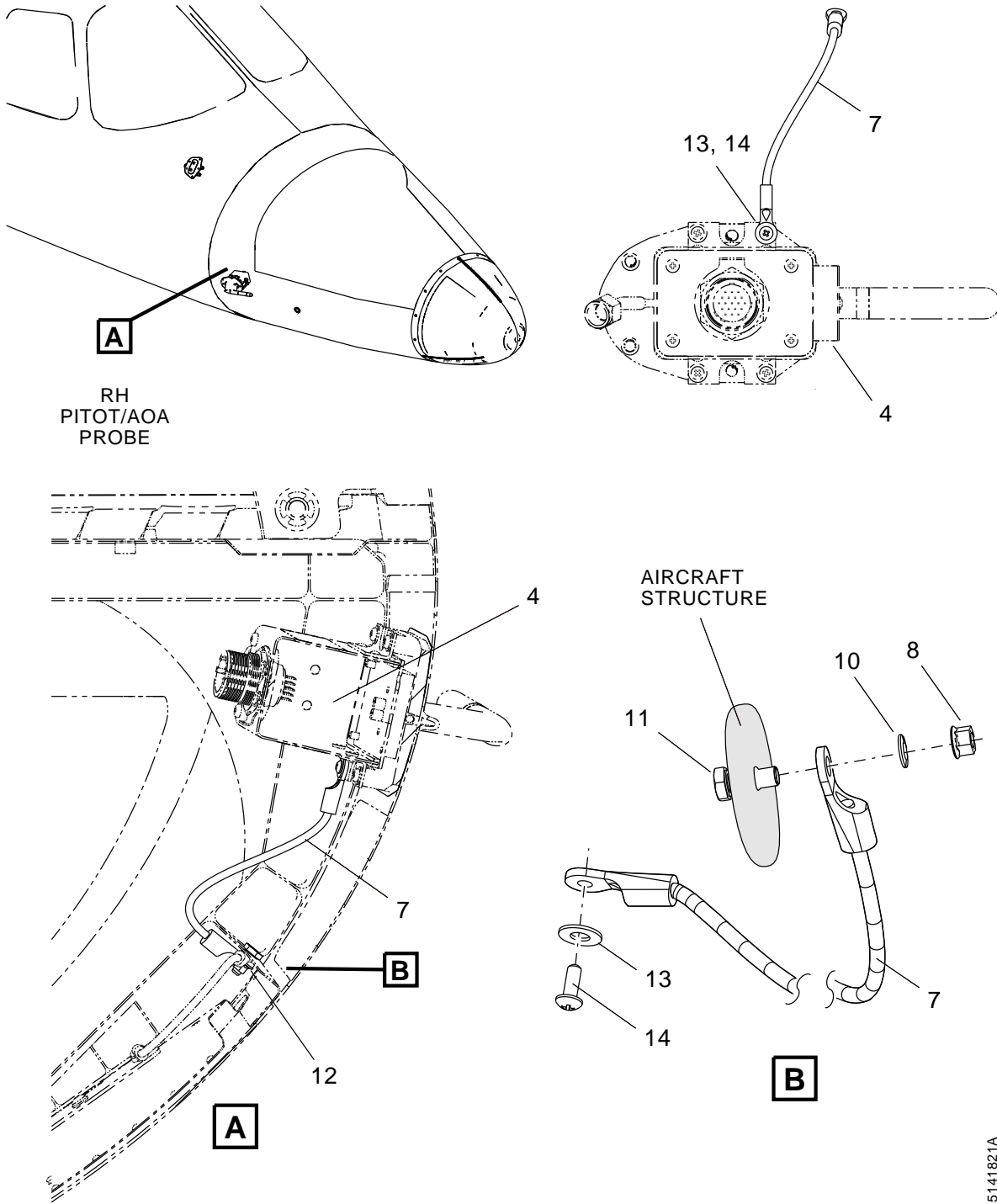

**Pitot/AOA Probes - Removal/Installation**  
**Figure 401 (Sheet 3 of 4)**

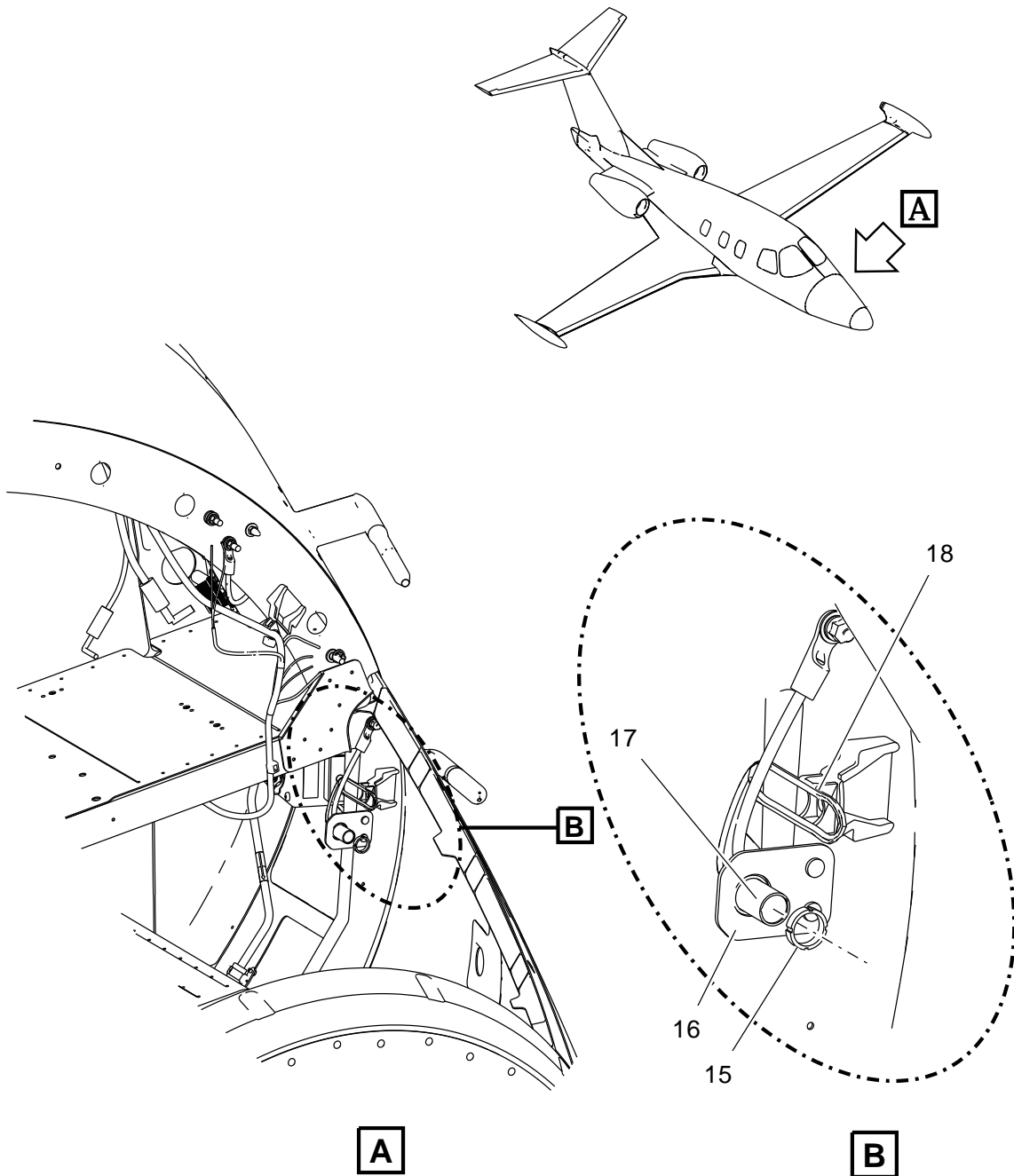

5171943A

**Pitot/AOA Probes - Removal/Installation**  
**Figure 401 (Sheet 4 of 4)**

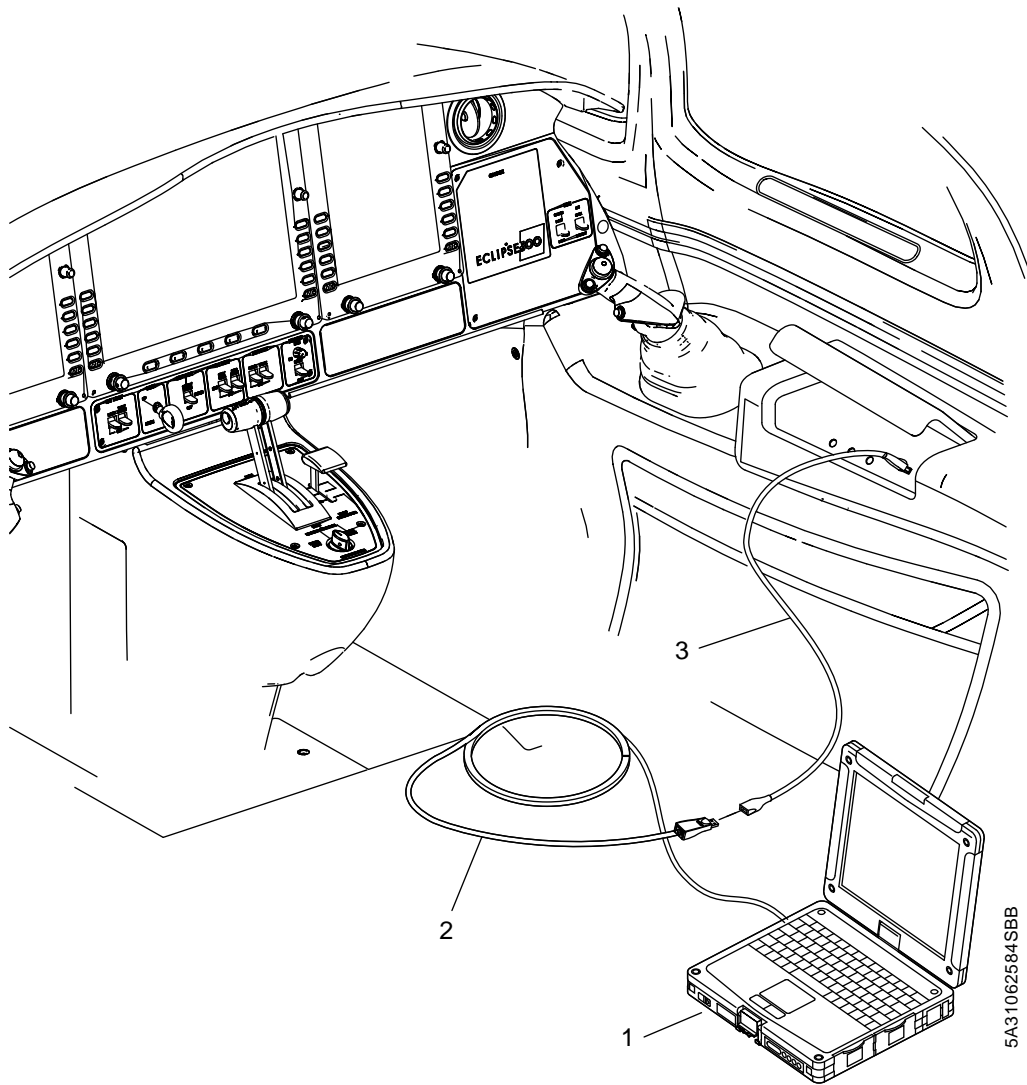

5A31062584 SBB

**Co-pilot's Armrest USB Port - AMC Hookup**  
**Figure 402 (Sheet 1 of 1)**

# AVIO MAINTENANCE COMPUTER

52 Doors	72 Engine	73 Fuel Ctrl	74 Ignition	75 Engine Air	76 Eng Ctrl	80 Starting
30 De-Ice	31 Instr	32 Ldg Gear	33 Lights	34 Nav/Pitot	35 Oxygen	36 Pneum
8 Weigh	21 Air Cond	22 Autopilot	24 Elec Pwr	26 Fire	27 Flt Ctrls	28 Fuel

VCS Door Cals ▼

VCS Door Cals

Start Done

Closed

10 9 8 7 6 5 4 3 2 1 0

9.49 Default

Fwd VCS Inlet 9.48

Open

10 9 8 7 6 5 4 3 2 1 0

Default 3.17

Closed

0 1 2 3 4 5 6 7 8 9 10

1.46 Default

Aft VCS Outlet 1.49

Open

0 1 2 3 4 5 6 7 8 9 10

Default 8.69

EA500.XXXX

DSU  
App

L-ACS

R-ACS

5080708B

**VCS Door Cals Page**  
**Figure 403 (Sheet 1 of 1)**

---

## **PITOT/AOA PROBE - INSTALLATION**

AMM-34-10-14-041-C-801

### **1. General**

- A. This task gives the procedures to install the Pitot/Angle of Attack (AOA) probes.

### **2. Job Set-Up**

SUBTASK AMM-34-10-10-041-C-921-001

(Refer to [Fig. 401, Sheet 1.](#))

- A. Make sure aircraft is in the same configuration as it was when the removal task was completed. Refer to [AMM-34-10-10-001-C-801 – Pitot/AOA Probes - Removal.](#)
- B. If the Pitot/AOA probe is new, check to see if a packing (support) block (1) is supplied with the unit.

**NOTE:** New assemblies may be shipped from the manufacturer with a packing block (1) in order to protect the device during shipping, handling and installation.

- (1) It is strongly recommended that new Pitot/AOA probe(s) should be mounted to the aircraft with the packing block (1) still in place in order to prevent pinching and kinking of the main plumbing line (2) and connection (3) during the installation process. It is also recommended that a Pitot cover be used on the Pitot/AOA probe as practical during and after installation in order to provide increased protection against foreign object damage (FOD).

### 3. Procedure

SUBTASK AMM-34-10-10-041-C-411-001

(Refer to [Fig. 401.](#))

**CAUTION:** REMOVE THE NOTED SCREW FROM THE PITOT/AOA PROBE ONLY.  
DO NOT LOOSEN OR DISTURB OTHER MOUNTING HARDWARE.

**NOTE:** The fastener securing the grounding jumper to the probe shall be installed using torque required to bring the bearing faces into positive contact and have Loctite 242 to applied to the screw threads.

- A. If required for the LH Pitot/AOA probe ([Fig. 401, Sheet 3](#)), install the grounding jumper (7) to the probe (4) using the existing washer (14) and screw (13) from the previously installed grounding jumper.
- B. If required for the RH Pitot/AOA probe ([Fig. 401, Sheet 4](#)), install the grounding jumper (7) to the Pitot/AOA probe (4) using the existing washer (14) and screw (13) from the previously installed grounding jumper.
- C. Install Pitot/AOA probe (4) and gasket (6) in structure (1) and align holes.
- D. Attach Pitot/AOA probe (4) to structure (1) with five screws (5).
- E. For the LH Pitot/AOA probe ([Fig. 401, Sheet 3](#)), install the grounding jumper (7) to the aircraft structure by placing hex head screw (11) through hole (12) and securing the grounding jumper with flat washer (10), lock washer (9), and self locking nut (8).
- F. For the RH Pitot/AOA probe ([Fig. 401, Sheet 4](#)), install the grounding jumper (7) to the aircraft structure by placing hex head screw (11) through hole (12) and securing the grounding jumper with flat washer (10), and self locking nut (8).
- G. Do electrical bonding of Pitot/AOA probe (4) to structure (1). Refer to [AMM-20-03-00-051-801 – Electrical Bonding - Maintenance Practices](#). Resistance must be 2.5 milliohms or less.
- H. Do electrical bonding of aft VCS door (12) per instructions in [AMM-21-10-15-041-801 – Aft VCS Door Actuator - Installation](#).
- I. Connect electrical connector (2) to Pitot/AOA probe (4).
- J. Install Auxiliary Heater electrical connector (17) to bracket (16).
- K. Secure electrical connector (17) with jam nut (15). Torque to 35-45 lbf.in (4.0-5.1 Nm)
- L. Connect Pitot/AOA Auxiliary Heater electrical connector (17) to aircraft harness.

**CAUTION:** DO NOT USE EXCESSIVE TORQUE. TOO MUCH TORQUE CAN DAMAGE AND DEFORM PLUMBING LINES, STRUCTURE, AND FASTENERS.

- M. Connect Pitot tube assembly (3) to Pitot/AOA probe (4). Torque to 20-30 lbf.in (2.3-3.4 Nm).

- N. Use PRC-Desoto aerodynamic smoothing sealant (PR-2050) to close gaps and seal around Pitot/AOA probes. [AMM-20-08-00-051-801 – Sealants and Adhesives - Maintenance Practices](#).

#### 4. **Job Close-Up**

SUBTASK AMM-34-10-10-041-C-921-002

**CAUTION:** MAKE SURE ANY PACKING/MATERIALS SUPPLIED WITH THE UNIT ARE REMOVED AND NOT LEFT IN PLACE BETWEEN THE PROBE BODY AND THE AIRCRAFT AFTER INSTALLATION.

- A. If applicable, discard packing block after installation.
- B. Do an inspection/check of the (applicable) Pitot/AOA probe following installation. Refer to [AMM-34-10-00-021-801 – Flight Environment Data - Inspection/Check](#).
- C. Reconnect the electrical connectors on the aft VCS door actuator if removed.
- D. Apply power to the aircraft.
- (1) Connect AMC to right armrest USB port. Refer to [Fig. 402](#).
- (2) Make sure that the Forward and Aft VCS doors have fully closed if opened. Refer to [AMM-21-00-00-071-801 – Air Conditioning - Adjustment/Test](#), .  
Refer to [Fig. 403](#).
- E. Do adjustment/test of the Pitot/AOA probe(s) following installation. Refer to [AMM-34-10-00-071-801 – Flight Environment Data - Adjustment/Test](#).

**CAUTION:** DURING THIS TEST, THE HEATERS WILL BE COMMANDED ON BY THE SYSTEM. RH AND LH PITOT/AOA PROBES WILL HEAT UP TO APPROXIMATELY 500°C. HARM TO PERSONNEL OR EQUIPMENT CAN OCCUR IF TOUCHING THE PROBES. DO NOT LEAVE ON FOR EXTENDED TIME. ALLOW 10 MINUTES AFTER TEST FOR PROBES TO COOL.

- F. Do adjustment/test of the Pitot/AOA probe heat. Refer to [AMM-30-30-00-071-C-801 – Pitot and Static Anti-Ice System - Adjustment/Test](#) .
- G. Install access panel that follows as necessary:
- Install 211 CT - Nose Access Panel. Refer to [AMM-06-50-00-051-801 – Aircraft Access Panels](#).
- H. Remove power from the aircraft.
- I. Remove all tools, equipment and unwanted material from work area.
- J. If all other maintenance is complete, return aircraft to service. Refer to [AMM-20-00-02-051-801 – Return To Service \(After Maintenance\)](#).

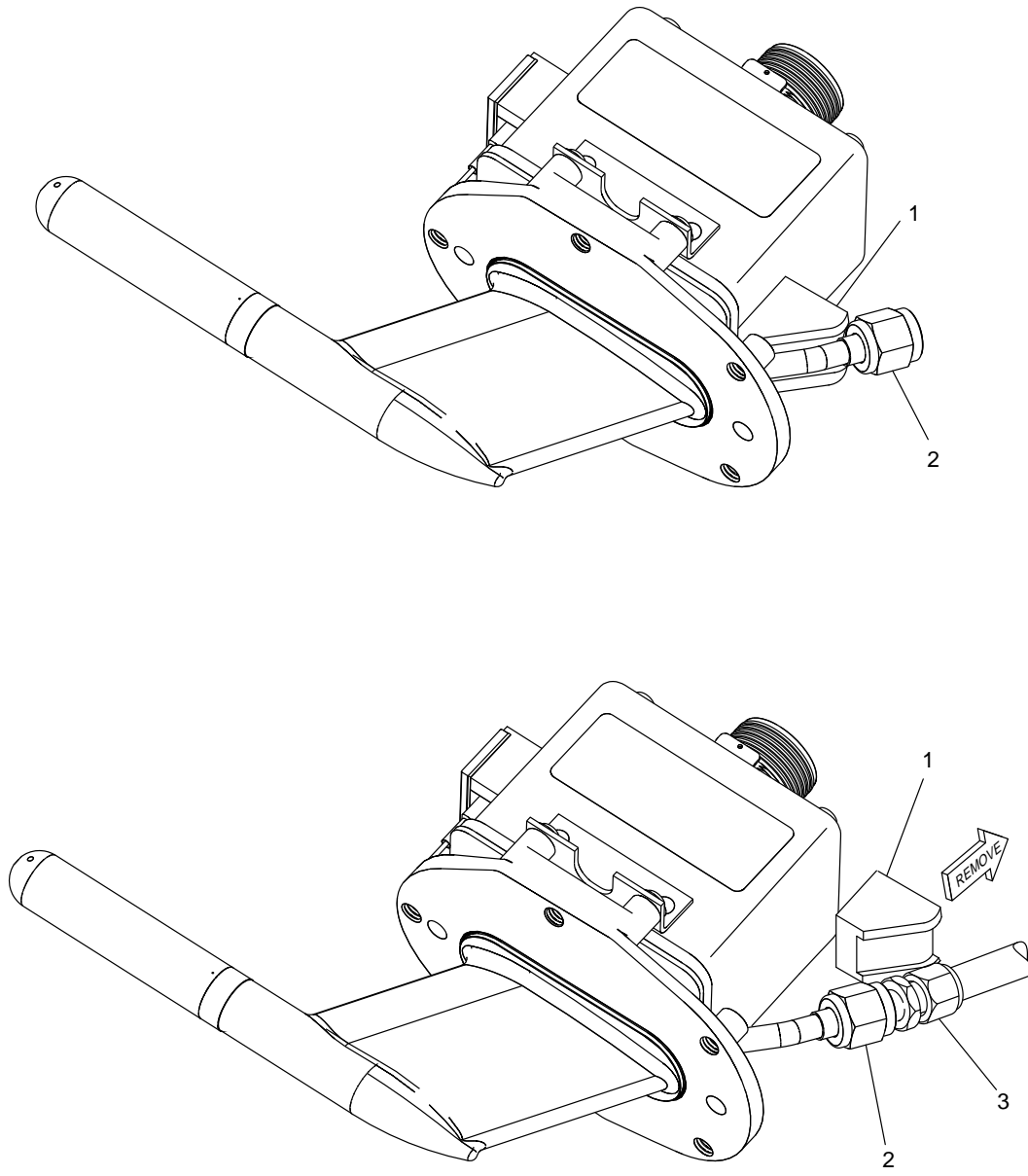

**Pitot/AOA Probes - Removal/Installation**  
**Figure 401 (Sheet 1 of 5)**

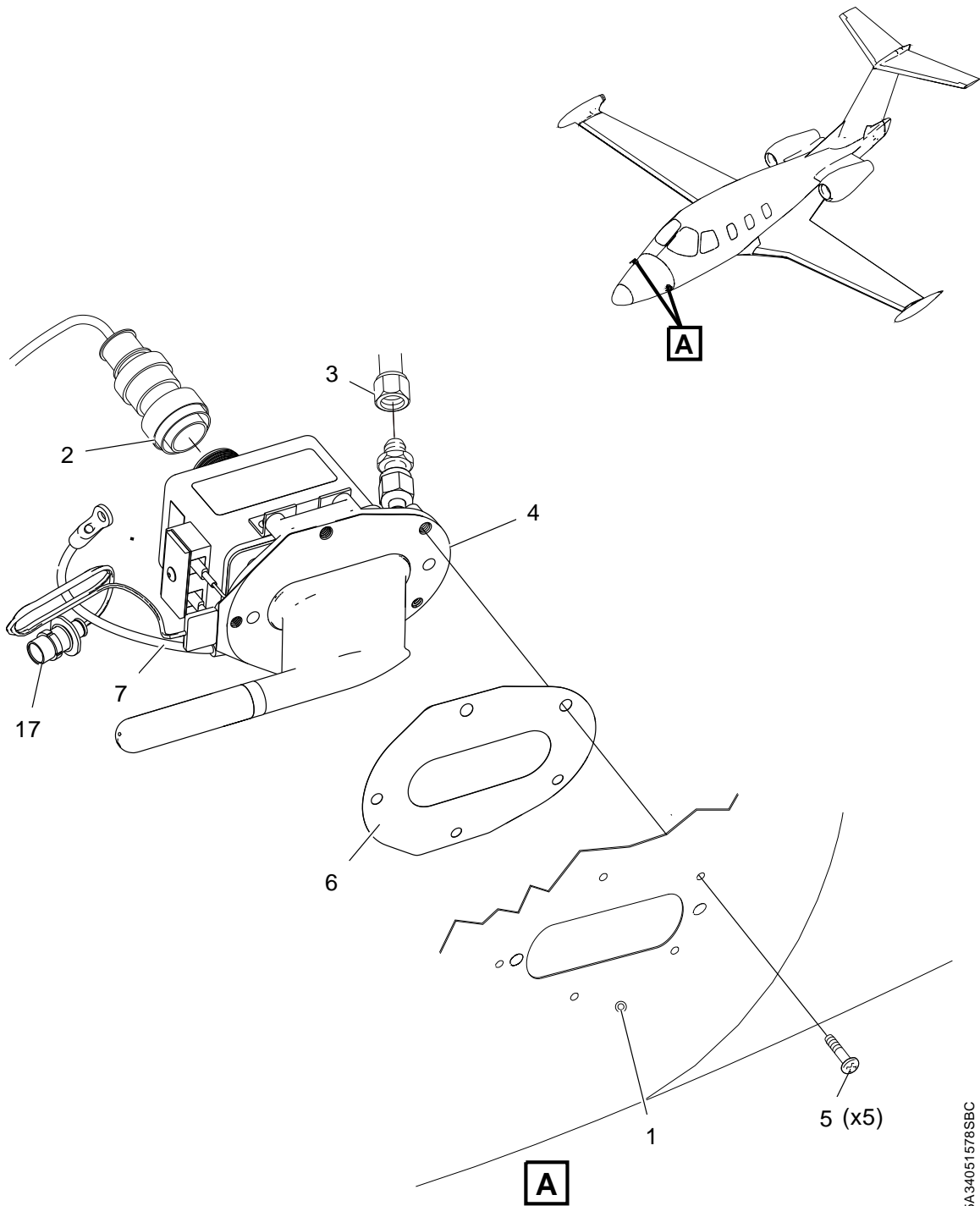

5A 34051578SBC

**Pitot/AOA Probes - Removal/Installation**  
**Figure 401 (Sheet 2 of 5)**

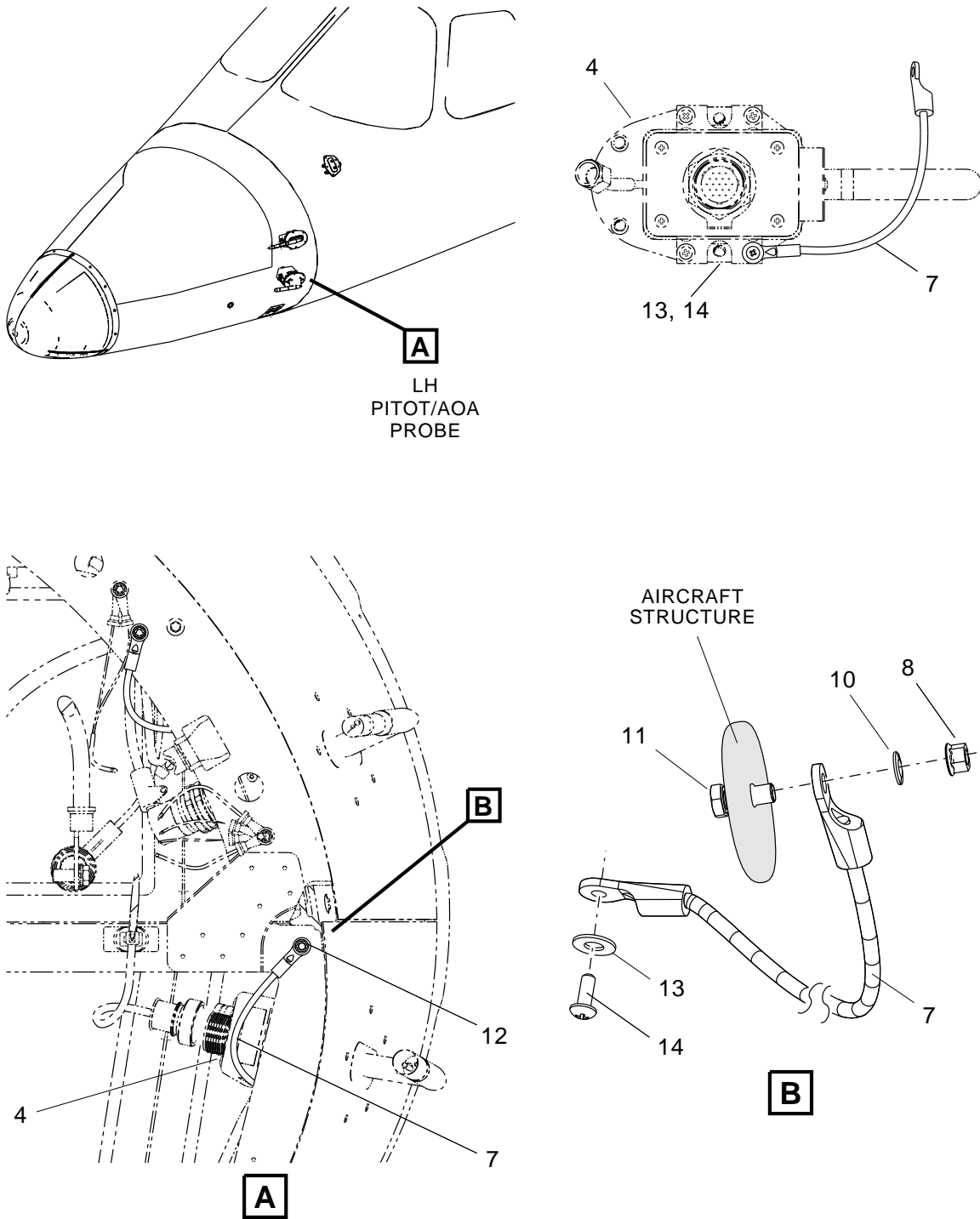

5141820A

**Pitot/AOA Probes - Removal/Installation**  
**Figure 401 (Sheet 3 of 5)**

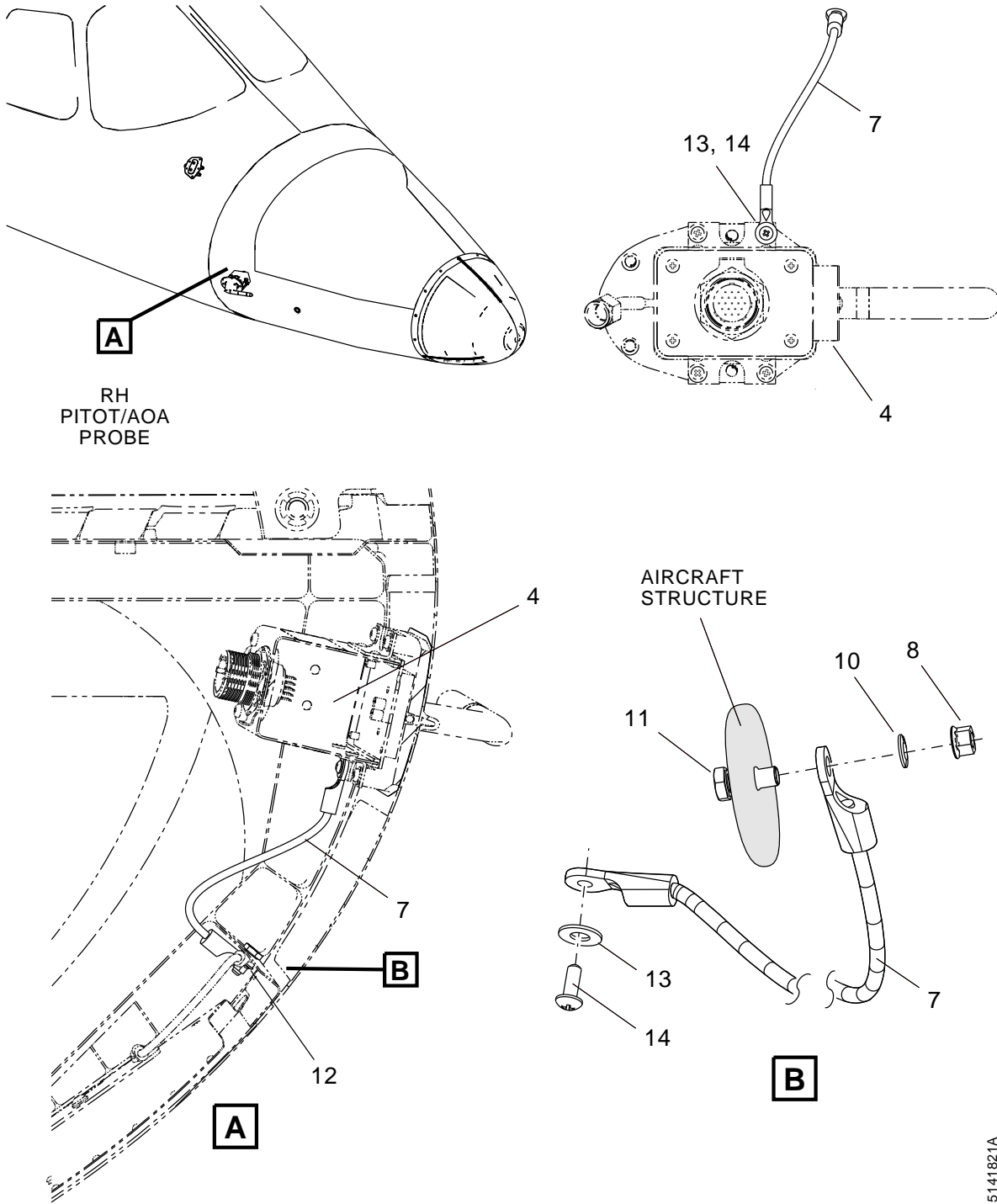

**Pitot/AOA Probes - Removal/Installation**  
**Figure 401 (Sheet 4 of 5)**

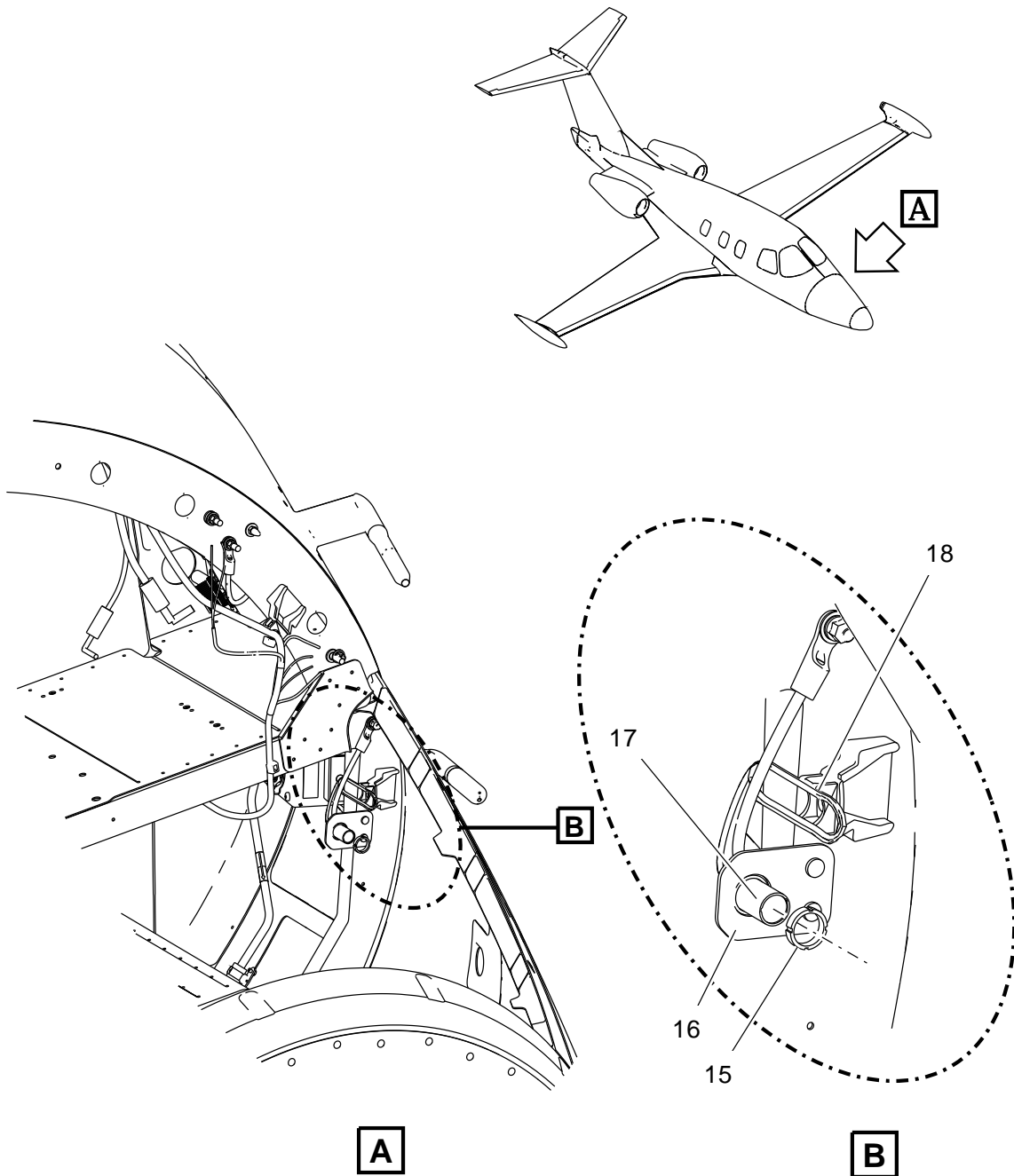

5171943A

**Pitot/AOA Probes - Removal/Installation**  
**Figure 401 (Sheet 5 of 5)**

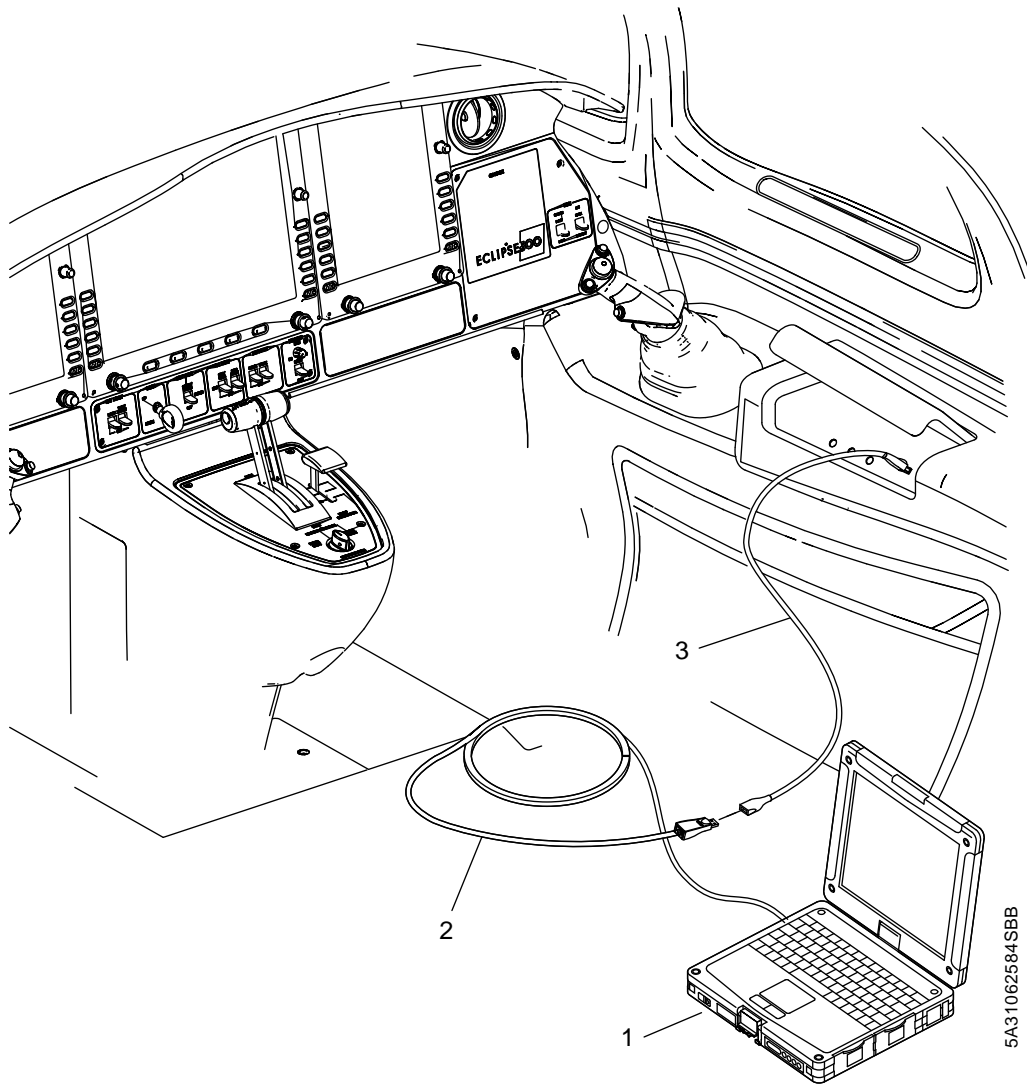

5A31062584 SBB

**Co-pilot's Armrest USB Port - AMC Hookup**  
**Figure 402 (Sheet 1 of 1)**

# AVIO MAINTENANCE COMPUTER

52 Doors	72 Engine	73 Fuel Ctrl	74 Ignition	75 Engine Air	76 Eng Ctrl	80 Starting
30 De-Ice	31 Instr	32 Ldg Gear	33 Lights	34 Nav/Pitot	35 Oxygen	36 Pneum
8 Weigh	21 Air Cond	22 Autopilot	24 Elec Pwr	26 Fire	27 Flt Ctrls	28 Fuel

VCS Door Cals

Start Done

Closed Fwd VCS Inlet 9.48 Open

10 9 8 7 6 5 4 3 2 1 0

9.49 Default << < > >> Default 3.17

Closed Aft VCS Outlet 1.49 Open

0 1 2 3 4 5 6 7 8 9 10

1.46 Default << < > >> Default 8.69

EA500.XXXX DSU App L-ACS R-ACS 5080708B

**VCS Door Cals Page**  
**Figure 403 (Sheet 1 of 1)**

---

## **STORMSCOPE - DESCRIPTION AND OPERATION**

AMM-34-40-50-081-A-801

### **1. Introduction**

- A. The Lightning Detection System (LDS) on the aircraft is referred to by its trademark name Stormscope®. Stormscope is a passive thunderstorm detection sensor. The sensor maps electrical discharge activity 360 degrees around the aircraft to a distance of 200 nautical miles for display on the GPS 400W display. Refer to [Fig. 1](#).

### **2. Description**

SUBTASK AMM-34-40-50-081-871-001

- A. The Stormscope system detects electrical discharges from thunderstorms within a 200 nm (370 km) radius of the aircraft for display on the pilot (left side) Garmin GPS 400W also referred to as GPS 1. Stormscope has a passive sensor that receives electronic signals through a stormscope antenna. The processor receives electrical discharge information from the antenna, processes it to determine range and azimuth and processes the heading input.

### **3. Operation**

SUBTASK AMM-34-40-50-081-871-002

- A. Stormscope provides the following functions:
- Two modes of weather display are available, Strike mode and Cell mode.
  - It works on the ground and in air giving the pilot information before take-off and in flight.
  - It displays range and azimuth to lightning strikes/lightning cells.
  - The antenna detects electrical and magnetic signatures of lightning strikes.
  - Operates passively requiring no transmitter.



**Stormscope - GPS 400W Display**  
**Figure 1 (Sheet 1 of 1)**

---

## **STORMSCOPE - DESCRIPTION AND OPERATION**

AMM-34-40-50-081-B-801

### **1. Introduction**

- A. The Lightning Detection System (LDS) on the aircraft is referred to by its trademark name Stormscope®. Stormscope is a passive thunderstorm detection sensor. The sensor maps electrical discharge activity 360 degrees around the aircraft to a distance of 200 nautical miles for display on the PFD. Refer to [Fig. 1](#).

### **2. Description**

SUBTASK AMM-34-40-50-081-B-871-001

- A. The Stormscope system detects electrical discharges from thunderstorms within a 200 nm (370 km) radius of the aircraft for display on the PFD. Stormscope has a passive sensor that receives electronic signals through a stormscope antenna. The processor receives electrical discharge information from the antenna, processes it to determine range and azimuth and processes the heading input.

### **3. Operation**

SUBTASK AMM-34-40-50-081-B-871-002

- A. Stormscope provides the following functions:
- Two modes of weather display are available, Strike mode and Cell mode.
  - It works on the ground and in air giving the pilot information before take-off and in flight.
  - It displays range and azimuth to lightning strikes/lightning cells.
  - The antenna detects electrical and magnetic signatures of lightning strikes.
  - Operates passively requiring no transmitter.



**PFD Stormscope Overlay (Cell Mode / Strike Mode)**  
**Figure 1 (Sheet 1 of 1)**

## STORMSCOPE - ADJUSTMENT/TEST

AMM-34-40-50-071-A-801

### 1. General

- A. This task gives the procedures to perform the Adjustment/Test for the Lightning Detection System (LDS). The LDS on the aircraft is referred to by its trademark name Stormscope®. The left hand GPS 400W is GPS 1 and right hand is GPS 2. Stormscope is only displayed on the left hand (GPS 1) unit. The Stormscope computer is on the options rack in the maintenance bay. The Stormscope antenna is mounted internally under the upper over fin fairing on top of the horizontal stabilizer.
- B. Testing Matrix:
  - (1) If the 331 DT - Upper Overfin Fairing is not installed, perform [SUBTASK AMM-34-40-50-071-A-701-001](#) .
  - (2) If the 331 DT - Upper Overfin Fairing is installed, perform [SUBTASK AMM-34-40-50-071-A-701-002](#) .

### 2. Equipment and Materials

**Table 501. Special Tools and Equipment (AMC Automated Procedure):**

Name and Part Number
External Battery Pack, (PowerVamp, Model APS1500)
WX-PA Portable Analyzer (L3 Com P/N 78-8060-5791-1)

### 3. Job Set-Up

SUBTASK AMM-34-40-50-071-A-921-001

- A. Make aircraft safe for maintenance. Refer to [AMM-20-00-01-051-801 – Make Safe For Maintenance](#).
- B. Connect an External Battery Pack to the aircraft EXTERNAL POWER RECEPTACLE and turn on power. Ensure the green EXT POWER light on the IPL is on. But do not turn on aircraft's power. Refer to [AMM-24-40-00-051-801 – External Power - Maintenance Practices](#).
- C. Remove (if necessary) 331 DT - Upper Over Fin Fairing. Refer to [AMM-55-10-12-001-801 – Overfin Fairing - Removal](#).
- D. Remove 311 AL - Maintenance Bay Panel. Refer to [AMM-06-50-00-051-801 – Aircraft Access Panels](#).

---

#### 4. Procedure – Upper Over Fin Fairing – NOT INSTALLED –

SUBTASK AMM-34-40-50-071-A-701-001

##### A. Test Set-Up

**NOTE:** The operator should be familiar with the WX-PA Portable Analyzer Kit.

- (1) Make sure that all aircraft power is off.
- (2) Attach the WX-PA test set's antenna to the Stormscope antenna.
  - (a) Position the WX-PA antenna on the Stormscope antenna as shown in [Fig. 501](#).
    - If necessary, use tape to secure WX-PA antenna; see [Fig. 502](#).
  - (b) Be sure to align the forwards arrows and position the WX-PA antenna suction cups forward of center along the longitudinal axis.
  - (c) Attach antenna cable grounding clip to nearby structure to obtain a good ground. See also [Fig. 503](#).
- (3) Route the WX-PA antenna cable away from the aircraft.
  - (a) Connect the antenna cable to the WX-PA test box.
  - (b) DO NOT POWER UP THE TEST SET.
- (4) On the IPL, set the SYS BATT and START BATT Switches to the ON (up) position and BUS TIE to AUTO (up) position.
  - (a) Clear any "MASTER CAUTIONS" and "MASTER WARNINGS" as needed.
  - (b) On the MFD, press the PROCEED Line Select Key (LSK).
- (5) If the aircraft is in the W-off-W condition, the following ECB's must be collared:

**CAUTION:** IF THE PITOT/STATIC HEAT ECB'S ARE NOT COLLARED OFF, HARM TO PERSONNEL OR AIR DATA TEST EQUIPMENT CAN OCCUR.

- (a) On the MFD ECB Page, scroll to ICE PROT and COLLAR the following ECBs:
  - ECB - DEICE MANIFOLD HTR (R AFT Bus)
  - ECB - L PITOT HEAT (L FWD Bus)
  - ECB - R PITOT HEAT (R FWD Bus)
  - ECB - L STATIC HEAT (BATT Bus)
  - ECB - L STATIC HEAT (R FWD Bus)
  - ECB - R STATIC HEAT (R FWD Bus)
  - ECB - R STATIC HEAT (L FWD Bus)
  - ECB - STBY PITOT HEAT (BATT Bus)
  - ECB - L WINDSHIELD HEAT (L AFT Bus)
  - ECB - R WINDSHIELD HEAT (R AFT Bus)
- (6) On the MFD ECB AVIONICS synoptic page, ensure the following ECB is AUTO-ON:

- ECB - LIGHTNING DETECT SYS (R AFT Bus)
- (7) On the MFD ECB AVIONICS synoptic page, PULL the following ECB:
- ECB - LIGHTNING DETECT SYS (R AFT Bus)
- (8) Turn on the left Garmin 400W and allow it to initialize:
- (a) On the left Garmin 400W, turn the small upper left knob clockwise until it “clicks”, to turn the left Garmin 400W on.
- After a short time period, the left Garmin 400W will display a features and status page, and will prompt a flashing “OK?”.
- (b) Press the ENT button.
- NOTE:** Wait until the satellite acquisition page has transitioned to the NAV page before proceeding.
- The left Garmin 400W will then display the INSTRUMENT PANEL SELF-TEST page, and will prompt a flashing “OK?”.
- (c) Press the ENT button.
- The left Garmin 400W will then display the satellite acquisition page and/or the NAV page.
- (9) On the left Garmin 400W, scroll the small inner knob (lower right corner) clockwise to select Lightning Detection (Stormscope) for display on the left Garmin 400W unit (“LTNG” page).
- NOTE:** Left Garmin 400W “LTNG” page will display “LIGHTNING FAILED”.
- (10) On the MFD ECB AVIONICS synoptic page, reset the following ECB:
- ECB - LIGHTNING DETECT SYS (R AFT Bus)
- (11) Make sure that no self-test failure messages appear.
- (12) Stormscope is now powered up and initialized.
- (a) Make sure that no self-test failure messages appear.
- (13) Make sure “LIGHTNING FAIL” annunciation on the GPS 400W extinguishes 10-20 seconds after ECB - LIGHTNING DETECT SYS (R AFT Bus) is RESET.
- NOTE:** The left Garmin display will annunciate “TEST” in the upper right corner for 10-20 seconds after the “LIGHTNING FAIL” annunciation extinguishes, indicating that the Stormscope computer is in self-test. The “TEST” annunciation will then change to “RATE”, unless a Stormscope self-test failure occurs. If a selftest failure occurs during initialization, determine the nature of the test failure prior to continuing with this test procedure.

**B. Initial System Test**Refer to [Fig. 504](#)

- (1) On the left Garmin 400W, select the 360° display mode (if not already in 360° mode) and verify proper 360° display format on the left Garmin 400W unit.
  - (a) If not already in 360° mode, on left Garmin 400W:
    - 1 Press MENU button.
    - 2 Use outer knob (lower right corner) to scroll down to “View 360?”.
    - 3 Press the ENT button.
- (2) On left Garmin 400W, select STRIKE mode (if not already in STRIKE mode). Verify STRIKE MODE is displayed on the left Garmin 400W Lightning display format.
  - (a) If not already in STRIKE mode, on left Garmin 400W:
    - 1 Press MENU button.
    - 2 Use outer knob (lower right corner) to scroll down to “Strike Mode?”.
    - 3 Press the ENT button.
- (3) On left Garmin 400W, set range to 100 NM (if not already set to 100 NM).

NOTE: Outer ring shows “100 nm”, Inner ring shows “50 nm”.

  - (a) If not already set to 100 NM, on left Garmin 400W:
    - 1 Press RNG button on right end (▲) to increase range.
    - 2 Press RNG button on left end (▼) to decrease range.
- (4) Make sure Strike RATE counter is displayed in STRIKE mode.

NOTE: Strike RATE counter should be displaying 0, unless there is real thunderstorm activity within detection range (nearby man-made electrical noise such as a blower motor or electric drill can also cause strike data to appear). If so, the test strike data in the following steps will be displayed along with real storm strike data (or man-made electrical strike data).
- (5) Tune the VHF 1 COMM radio to a test frequency.
- (6) Key the VHF 1 Comm mic (transmit on VHF 1 Comm) repeatedly.
  - (a) Make sure no strike data appears on the GPS 400W Lightning display as a result of keying the VHF 1 transmitter.
- (7) Tune the VHF 2 COMM radio to a test frequency.
  - (a) Select COM 2 as the ACTIVE radio.
- (8) Key the VHF 2 Comm mic (transmit on VHF 2 Comm) repeatedly.
  - (a) Make sure no strike data appears on the GPS 400W Lightning display as a result of keying the VHF 2 transmitter.

- (9) Verify aircraft is positioned so that it can be freely turned 45° ( $\pm 5^\circ$ ) clockwise (to the right).
  - (a) Make sure area around aircraft is clear.
  - (b) Make sure that WX-PA tester can be moved with the aircraft.
  - (c) Make sure adequate cable is deployed from the external power cart to allow the aircraft to turn 45° to the right.
- (10) Power up the WX-PA Portable Analyzer unit.
  - After the WX-PA completes self-test, the MODE MENU will be displayed.
- (11) On the WX-PA, select “Continuous Out” on the MODE MENU, then press the MENU/ENTR button once (so that WX-PA indicates “PAUSED” and not “RUNNING”).
- (12) On the WX-PA, press the FLAPS/A button to select top mount antenna configuration.
- (13) On the WX-PA, select a cardinal bearing of 0° and a range of 55 NM.
  - Use F1 and F2 buttons to adjust range and the F3 and F4 buttons to adjust bearing.
- (14) On the WX-PA, with “Continuous Out” still selected on the MODE MENU, push the MENU/ENTR button once so that the WX-PA indication changes from “PAUSED” to “RUNNING”.

### C. Cardinal Bearings Test

- (1) On the LH Garmin 400W, press the MENU button. Highlight CLEAR STORM DATA? (if not already highlighted), then press the ENT button.
- (2) Verify that the Strike Rate is displayed on the Garmin 400W as shown in [Fig. 504](#).
  - (a) When Strike Rate reaches approximately 580+/-40 strikes per minute, verify that the strikes appear within the required bearing limits for each of the settings on the WX-PA as shown in [Table 502](#).
 

**NOTE:** Strikes may appear approximately at half of the range selected.

**NOTE:** Clear the storm data from the Garmin 400W after each test.
- (3) On the WX-PA, push 2<sup>nd</sup>, then push MENU/ENTR to return to Main Menu.

**Table 502. Cardinal Bearings Tests**

<b>TEST - 1</b>		<b>Result</b> (PASS/FAIL)
<ul style="list-style-type: none"> <li>• Set WX-PA range = 55 NM</li> <li>• Set Garmin 400W range = 150 NM</li> </ul>		
Set WX-PA bearing = 000°	Verify the displayed bearing = 000 ±10°	
Set WX-PA bearing = 090°	Verify the displayed bearing = 090 ±10°	
Set WX-PA bearing = 180°	Verify the displayed bearing = 180 ±10°	
Set WX-PA bearing = 270°	Verify the displayed bearing = 270 ±10°	
<b>TEST - 2</b>		<b>Result</b> (PASS/FAIL)
<ul style="list-style-type: none"> <li>• Set WX-PA range = 30 NM</li> <li>• Set Garmin 400W range = 100 NM</li> </ul>		
Set WX-PA bearing = 000°	Verify the displayed bearing = 000 ±10°	
Set WX-PA bearing = 090°	Verify the displayed bearing = 090 ±10°	
Set WX-PA bearing = 180°	Verify the displayed bearing = 180 ±10°	
Set WX-PA bearing = 270°	Verify the displayed bearing = 270 ±10°	
<b>TEST - 3</b>		<b>Result</b> (PASS/FAIL)
<ul style="list-style-type: none"> <li>• Set WX-PA range = 15 NM</li> <li>• Set Garmin 400W range = 50 NM</li> </ul>		
Set WX-PA bearing = 000°	Verify the displayed bearing = 000 ±10°	
Set WX-PA bearing = 090°	Verify the displayed bearing = 090 ±10°	
Set WX-PA bearing = 180°	Verify the displayed bearing = 180 ±10°	
Set WX-PA bearing = 270°	Verify the displayed bearing = 270 ±10°	

---

**D. Heading Input Check**

- (1) On the WX-PA, select “Continuous Out” on the MODE MENU, then press the MENU/ENTR button once (so that WX-PA indicates “PAUSED” and not “RUNNING”).
- (2) On the WX-PA, press the FLAPS/A button to select top mount antenna configuration (if not already selected).
- (3) On the WX-PA, select a cardinal bearing of 180° and a range of 75 NM.
  - Use F1 and F2 buttons to adjust range and the F3 and F4 buttons to adjust bearing.
- (4) On the WX-PA, with “Continuous Out” still selected on the MODE MENU, press the MENU/ENTR button once so that WX-PA indication changes from “PAUSED” to “RUNNING”.
- (5) On the left hand GPS 400W (GPS 1), push the MENU button. Highlight CLEAR STORM DATA? (if not already highlighted), then push the ENT button.

NOTE: Strike RATE will recede then ramp up toward 600 ± 200 strikes per minute again.
- (6) Observe the GPS 400W Lightning display to ensure proper positioning of the test strikes, based on range and bearing settings on the WX-PA.
  - (a) Make sure that test strikes appearing on the GPS 400W Lightning display are plotted at 180 ± 10° and approximately 75 NM.
- (7) Make sure that the Strike RATE counter is strikes (600 ± 200 strikes per minute).
- (8) With aircraft magnetic heading active, turn the aircraft 45 ± 5° to the right.
- (9) Make sure that previously plotted discharge points move approximately 45° counterclockwise (approximately 135° relative on the GPS 400W display).

---

**5. Procedure – Upper Over Fin Fairing – INSTALLED –**

SUBTASK AMM-34-40-50-071-A-701-002

**A. Test Set-Up**

**NOTE:** With the WX-PA antenna placed on top of the fin fairing cap (over the Stormscope antenna), the Stormscope unit will plot data on the GPS 400W display at a farther range than the range selected on the WX-PA. This is because of the greater offset distance between the WX-PA antenna and the Stormscope antenna. For example, in the following steps, a test range of 30 NM is selected and the resulting displayed strikes occur at approximately 50 NM.

**IMPORTANT!** If for any reason the WX-PA tester produces “double image” lightning strikes on the Garmin 400W display, where the programmed strike pattern appears and additional strikes appear on a reciprocal bearing (180° away), then the Upper Over Fin Fairing must be removed and the “Procedure (Upper Over Fin Fairing NOT Installed)” must be performed. Refer to [SUBTASK AMM-34-40-50-071-A-701-001](#).

**NOTE:** Operator should be familiar with the WX-PA Portable Analyzer Kit.

- (1) Make sure that all aircraft power is off.
- (2) Attach the WX-PA test set’s antenna on top of the vertical tail fin fairing cap (over the Stormscope antenna).
  - (a) Position the WX-PA antenna on the fin fairing cap 5.75 inches aft of the top center fastener.
    - If necessary, use tape to secure WX-PA antenna to the fin fairing cap; see [Fig. 502](#).
  - (b) Be sure to align the WX-PA antenna’s arrow pointing forward, centered on the top of the fairing.
- (3) Route the WX-PA antenna cable away from the aircraft.
  - (a) Connect the antenna cable to the WX-PA test box.
  - (b) DO NOT POWER UP THE TEST SET.
- (4) On the IPL set the SYS BATT and START BATT switches to the ON (up) position and BUS TIE to AUTO (up) position.
  - (a) Clear any “MASTER CAUTIONS” and “MASTER WARNINGS” as needed.
  - (b) On the MFD, press the PROCEED Line Select Key (LSK).

- (5) If the aircraft is in the W-off-W condition, the following ECB's must be collared:

**CAUTION:** IF THE PITOT/STATIC HEAT ECB'S ARE NOT COLLARED OFF, HARM TO PERSONNEL OR AIR DATA TEST EQUIPMENT CAN OCCUR.

- (a) On the MFD ECB Page, scroll to ICE PROT and COLLAR the following ECBs:

- ECB - DEICE MANIFOLD HTR (R AFT Bus)
- ECB - L PITOT HEAT (L FWD Bus)
- ECB - R PITOT HEAT (R FWD Bus)
- ECB - L STATIC HEAT (BATT Bus)
- ECB - L STATIC HEAT (R FWD Bus)
- ECB - R STATIC HEAT (R FWD Bus)
- ECB - R STATIC HEAT (L FWD Bus)
- ECB - STBY PITOT HEAT (BATT Bus)
- ECB - L WINDSHIELD HEAT (L AFT Bus)
- ECB - R WINDSHIELD HEAT (R AFT Bus)

- (6) On the MFD ECB AVIONICS synoptic page, ensure the following ECB is AUTO-ON:

- ECB - LIGHTNING DETECT SYS (R AFT Bus)

- (7) On the MFD ECB AVIONICS synoptic page, PULL the following ECB:

- ECB - LIGHTNING DETECT SYS (R AFT Bus)

- (8) Turn on left Garmin 400W and allow it to initialize:

- (a) On the left Garmin 400W, turn the small upper left knob clockwise until it "clicks", to turn the left Garmin 400W on.

- After a short time period, the left Garmin 400W will display a features and status page, and will prompt a flashing "OK?".

- (b) Press the ENT button.

**NOTE:** Wait until the satellite acquisition page has transitioned to the NAV page before proceeding.

- The left Garmin 400W will then display the INSTRUMENT PANEL SELF-TEST page, and will prompt a flashing "OK?".

- (c) Press the ENT button.

- The left Garmin 400W will then display the satellite acquisition page and/or the NAV page.

- (9) On the left Garmin 400W, scroll the small inner knob (lower right corner) clockwise to select Lightning Detection (Stormscope) for display on the left Garmin 400W unit ("LTNG" page).

**NOTE:** Left Garmin 400W "LTNG" page will display "LIGHTNING FAILED".

- (10) On the MFD ECB AVIONICS synoptic page, reset the following ECB:

- ECB - LIGHTNING DETECT SYS (R AFT Bus)
- (11) Make sure that no self-test failure messages appear.
  - (12) Stormscope is now powered up and initialized.
    - (a) Make sure that no self-test failure messages appear.
  - (13) Make sure “LIGHTNING FAIL” annunciation on the GPS 400W extinguishes 10-20 seconds after ECB - LIGHTNING DETECT SYS (R AFT Bus) is RESET.

**NOTE:** The left Garmin display will annunciate “TEST” in the upper right corner for 10-20 seconds after the “LIGHTNING FAIL” annunciation extinguishes, indicating that the Stormscope computer is in self-test. The “TEST” annunciation will then change to “RATE”, unless a Stormscope self-test failure occurs. If a selftest failure occurs during initialization, determine the nature of the test failure prior to continuing with this test procedure.

## B. Initial System Test

- (1) On the left Garmin 400W, select the 360° display mode (if not already in 360° mode). Verify proper 360° display format on the left Garmin 400W unit.
  - (a) If not already in 360° mode, on left Garmin 400W:
    - 1 Press MENU button.
    - 2 Use outer knob (lower right corner) to scroll down to “View 360?”.
    - 3 Press the ENT button.
- (2) On left Garmin 400W, select STRIKE mode (if not already in STRIKE mode). Verify STRIKE MODE is displayed on the left Garmin 400W Lightning display format.
  - (a) If not already in STRIKE mode, on left Garmin 400W:
    - 1 Press MENU button.
    - 2 Use outer knob (lower right corner) to scroll down to “Strike Mode?”.
    - 3 Press the ENT button.
- (3) On left Garmin 400W, set range to 100 NM (if not already set to 100 NM).

**NOTE:** Outer ring; inner ring will say “50 nm”.

  - (a) If not already set to 100 NM, on left Garmin 400W:
    - 1 Press RNG button on right end (▲) to increase range.
    - 2 Press RNG button on left end (▼) to decrease range.
- (4) Make sure Strike RATE counter is displayed in STRIKE mode.

**NOTE:** Strike RATE counter should be displaying 0, unless there is real thunderstorm activity within detection range (nearby man-made electrical noise such as a blower motor or electric drill can also cause strike data to appear). If so, the test strike data in the following steps will be displayed along with real storm strike data (or man-made electrical strike data).
- (5) Tune the VHF 1 COMM radio to a test frequency.

- 
- (6) Key the VHF 1 Comm mic (transmit on VHF 1 Comm) repeatedly.
    - (a) Make sure no strike data appears on the GPS 400W Lightning display as a result of keying the VHF 1 transmitter.
  - (7) Tune the VHF 2 COMM radio to a test frequency.
    - (a) Select COM 2 as the ACTIVE radio.
  - (8) Key the VHF 2 Comm mic (transmit on VHF 2 Comm) repeatedly.
    - (a) Make sure no strike data appears on the GPS 400W Lightning display as a result of keying the VHF 2 transmitter.
  - (9) Verify aircraft is positioned so that it can be freely turned 45° ( $\pm 5^\circ$ ) clockwise (to the right).

Verify aircraft is positioned so that it can be freely turned 45° to the right. Make sure area around aircraft is clear.

    - (a) Make sure area around aircraft is clear.
    - (b) Make sure that WX-PA tester can be moved with the aircraft.
    - (c) Make sure adequate cable is deployed from the external power cart to allow the aircraft to turn 45° to the right.
  - (10) Power up the WX-PA Portable Analyzer unit.
    - After the WX-PA completes self-test, the MODE MENU will be displayed.
  - (11) On the WX-PA, select “Continuous Out” on the MODE MENU, then push the MENU/ENTR button once (so that WX-PA indicates “PAUSED” and not “RUNNING”).
  - (12) On the WX-PA, push the FLAPS/A button to select top mount antenna configuration.
  - (13) On the WX-PA, select a cardinal bearing of 0° and a range of 55 NM.
    - Use F1 and F2 buttons to adjust range and the F3 and F4 buttons to adjust bearing.
  - (14) On the WX-PA, with “Continuous Out” still selected on the MODE MENU, push the MENU/ENTR button once so that the WX-PA indication changes from “PAUSED” to “RUNNING”.

### C. Cardinal Bearings Test

- (1) On the LH Garmin 400W, press the MENU button. Highlight CLEAR STORM DATA? (if not already highlighted), then press the ENT button.
- (2) Verify that the Strike Rate is displayed on the Garmin 400W as shown in [Fig. 504](#).
  - (a) When Strike Rate reaches approximately 580+/-40 strikes per minute, verify that the strikes appear within the required bearing limits for each of the settings on the WX-PA as shown in [Table 502](#).
 

**NOTE:** Strikes may appear approximately at half of the range selected.

**NOTE:** Clear the storm data from the Garmin 400W after each test.
- (3) On the WX-PA, push 2<sup>nd</sup>, then push MENU/ENTR to return to Main Menu.

**Table 503. Cardinal Bearings Tests**

<b>TEST - 1</b>		<b>Result</b> (PASS/FAIL)
<ul style="list-style-type: none"> <li>• Set WX-PA range = 55 NM</li> <li>• Set Garmin 400W range = 150 NM</li> </ul>		
Set WX-PA bearing = 000°	Verify the displayed bearing = 000 ±10°	
Set WX-PA bearing = 090°	Verify the displayed bearing = 090 ±10°	
Set WX-PA bearing = 180°	Verify the displayed bearing = 180 ±10°	
Set WX-PA bearing = 270°	Verify the displayed bearing = 270 ±10°	
<b>TEST - 2</b>		<b>Result</b> (PASS/FAIL)
<ul style="list-style-type: none"> <li>• Set WX-PA range = 30 NM</li> <li>• Set Garmin 400W range = 100 NM</li> </ul>		
Set WX-PA bearing = 000°	Verify the displayed bearing = 000 ±10°	
Set WX-PA bearing = 090°	Verify the displayed bearing = 090 ±10°	
Set WX-PA bearing = 180°	Verify the displayed bearing = 180 ±10°	
Set WX-PA bearing = 270°	Verify the displayed bearing = 270 ±10°	
<b>TEST - 3</b>		<b>Result</b> (PASS/FAIL)
<ul style="list-style-type: none"> <li>• Set WX-PA range = 15 NM</li> <li>• Set Garmin 400W range = 50 NM</li> </ul>		
Set WX-PA bearing = 000°	Verify the displayed bearing = 000 ±10°	
Set WX-PA bearing = 090°	Verify the displayed bearing = 090 ±10°	
Set WX-PA bearing = 180°	Verify the displayed bearing = 180 ±10°	
Set WX-PA bearing = 270°	Verify the displayed bearing = 270 ±10°	

---

**D. Heading Input Check**

- (1) On the WX-PA, select “Continuous Out” on the MODE MENU, then press the MENU/ENTR button once (so that WX-PA indicates “PAUSED” and not “RUNNING”).
- (2) On the WX-PA, press the FLAPS/A button to select top mount antenna configuration (if not already selected).
- (3) On the WX-PA, select a cardinal bearing of 180° and a range of 30 NM.
  - Use F1 and F2 buttons to adjust range and the F3 and F4 buttons to adjust bearing.
- (4) On the WX-PA, with “Continuous Out” still selected on the MODE MENU, then press the MENU/ENTR button once so that WX-PA indication changes from “PAUSED” to “RUNNING”.
- (5) On the left hand GPS 400W (GPS 1), push the MENU button. Highlight CLEAR STORM DATA? (if not already highlighted), then push the ENT button.

NOTE: Strike RATE will recede then ramp up toward 600 ± 200 strikes per minute again.
- (6) Observe the GPS 400W Lightning display to ensure proper positioning of the test strikes, based on range and bearing settings on the WX-PA.
  - (a) Make sure that test strikes appearing on the GPS 400W Lightning display are plotted at 180 ± 10° and approximately 50 NM.
- (7) Make sure that the Strike RATE counter is strikes (600 ± 200 strikes per minute).
- (8) With aircraft magnetic heading active, turn the aircraft 45 ± 5° to the right.
- (9) Make sure that previously plotted discharge points move approximately 45° counterclockwise (approximately 135° relative on the GPS 400W display).

## 6. **Job Close-Up**

SUBTASK AMM-34-40-50-071-A-921-002

- A. If no other work is to be performed, turn off the aircraft power by setting the SYS BATT and START BATT Switches to the OFF (down) position and BUS TIE to OPEN (down) position.
- B. If no other requirements for External Power, disconnect External Battery Pack from the aircraft EXTERNAL POWER RECEPTICLE.
- C. Install (if removed) 331 DT - Upper Overfin Fairing. Refer to [AMM-06-50-00-051-801 – Aircraft Access Panels](#) for location and installation instructions.
- D. Install (if removed) 311 AL - Maintenance Bay Panel. Refer to [AMM-06-50-00-051-801 – Aircraft Access Panels](#) for location and installation instructions.
- E. Remove all tools, equipment and unwanted material from work area.
- F. If all other maintenance is complete, return aircraft to service. Refer to [AMM-20-00-02-051-801 – Return To Service \(After Maintenance\)](#).

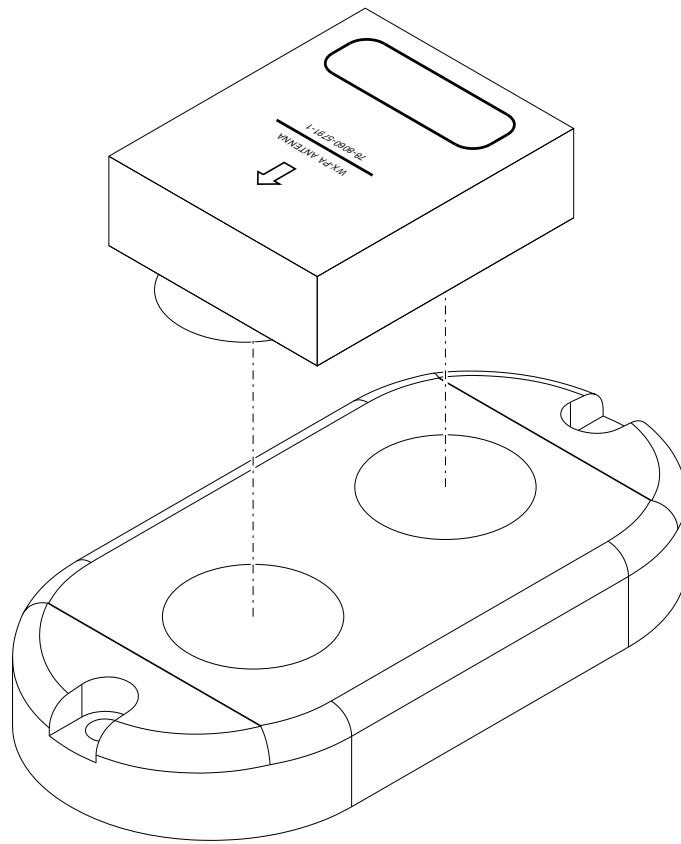

5131784A

**WX-PA Antenna Alignment**  
**Figure 501 (Sheet 1 of 1)**

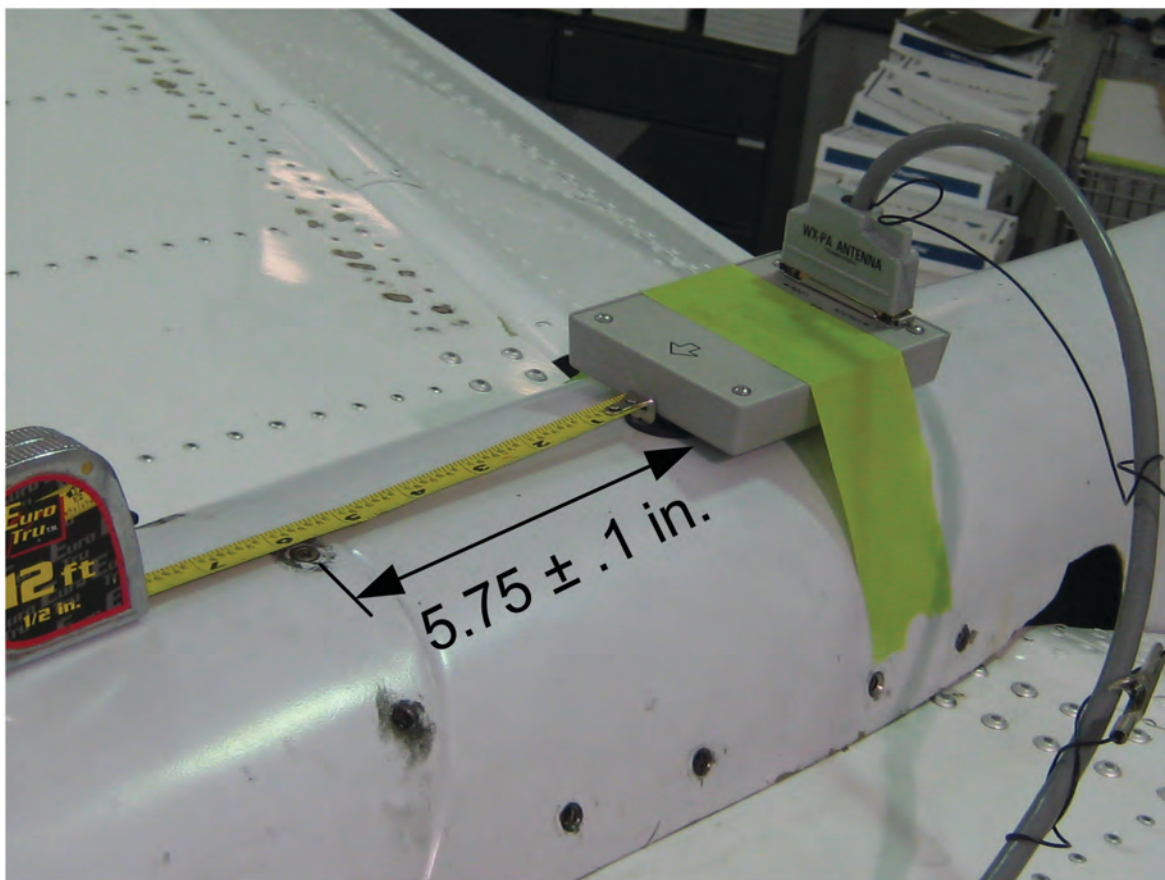

**Positioning the WX-PA Antenna on the Over Fin Fairing  
Figure 502 (Sheet 1 of 1)**

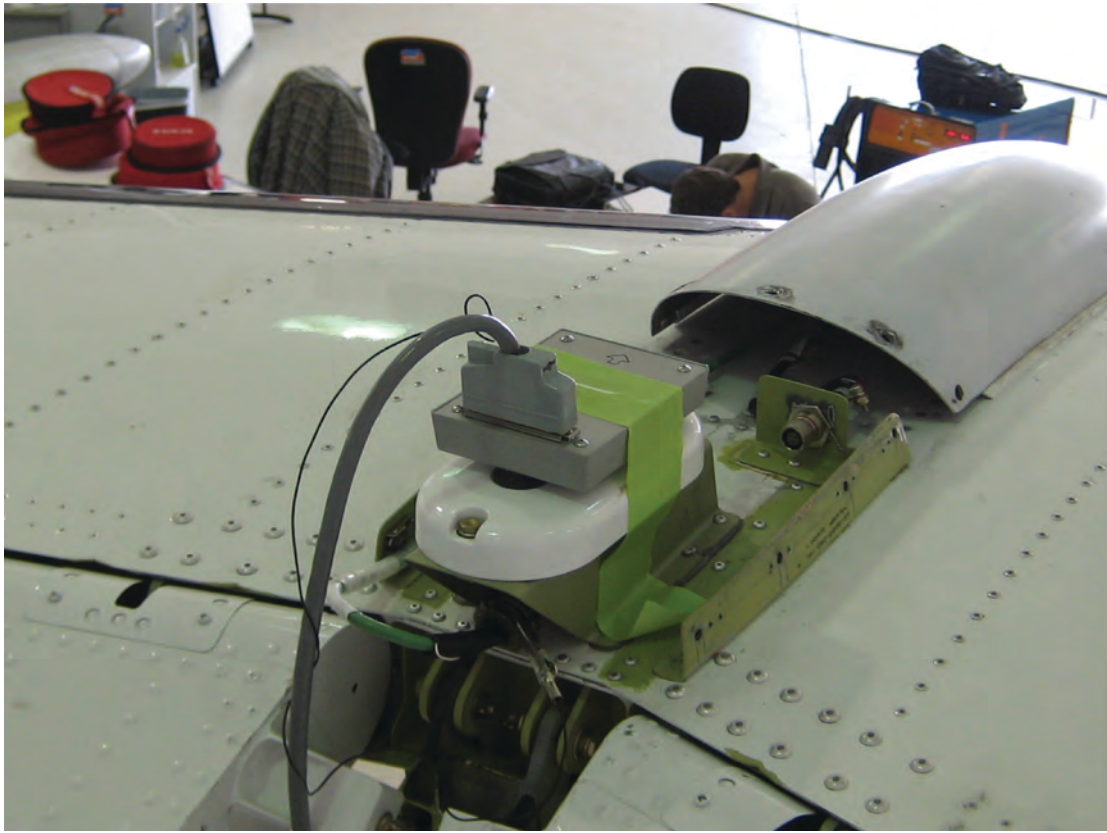

5141785A

**WX-PA Antenna Attachment  
Figure 503 (Sheet 1 of 1)**



**Stormscope — GPS 400W Display  
Figure 504 (Sheet 1 of 1)**

## STORMSCOPE - ADJUSTMENT/TEST

AMM-34-40-50-071-B-801

### 1. General

- A. This task gives the procedures to perform the Adjustment/Test for the Lightning Detection System (LDS). The LDS on the aircraft is referred to by its trademark name Stormscope®. The Stormscope computer is on the options rack in the maintenance bay. The Stormscope antenna is mounted internally under the upper over fin fairing on top of the horizontal stabilizer.
- B. Testing Matrix:
  - (1) If the 331 DT - Upper Overfin Fairing is removed, perform [SUBTASK AMM-34-40-50-071-B-701-001](#).
  - (2) If the 331 DT - Upper Overfin Fairing is installed, perform [SUBTASK AMM-34-40-50-071-B-701-002](#).

### 2. Equipment and Materials

**Table 501. Special Tools and Equipment**

Name and Part Number
External Battery Pack, (PowerVamp, Model APS1500)
WX-PA Portable Analyzer (L3 Com P/N 78-8060-5791-1)

### 3. Job Set-Up

SUBTASK AMM-34-40-50-071-B-921-001

- A. Make aircraft safe for maintenance. Refer to [AMM-20-00-01-051-801 – Make Safe For Maintenance](#).
- B. Connect an External Battery Pack to the aircraft EXTERNAL POWER RECEPTACLE and turn on power. Ensure the green EXT POWER light on the IPL is on. But do not turn on aircraft's power. Refer to [AMM-24-40-00-051-801 – External Power - Maintenance Practices](#).
- C. Remove (if necessary) 331 DT - Upper Over Fin Fairing. Refer to [AMM-55-10-12-001-801 – Overfin Fairing - Removal](#).

#### 4. Procedure – Upper Over Fin Fairing – NOT INSTALLED –

SUBTASK AMM-34-40-50-071-B-701-001

##### A. Test Set-Up

- (1) Attach the WX-PA test set's antenna to the LDS NY-163 antenna.
  - (a) Position the WX-PA antenna on the LDS antenna as shown in [Fig. 501](#).
    - If necessary, use tape to secure WX-PA antenna; see [Fig. 502](#).
  - (b) Be sure to align the forwards arrows and position the WX-PA antenna suction cups forward of center along the longitudinal axis.
  - (c) Attach antenna cable grounding clip to nearby structure to obtain a good ground. See also [Fig. 503](#).
- (2) Route the WX-PA antenna cable away from the aircraft.
  - (a) Connect the antenna cable to the WX-PA test box.
  - (b) DO NOT POWER UP THE TEST SET.
- (3) On the IPL, set the SYS BATT and START BATT Switches to the ON (up) position and BUS TIE to AUTO (up) position.
  - (a) Clear any "MASTER CAUTIONS" and "MASTER WARNINGS" as needed.
  - (b) On the MFD, press the PROCEED Line Select Key (LSK).
- (4) Verify that no CAS messages are displayed indicating Lightning equipment failures.
- (5) On the MFD ECB AVIONICS synoptic page, PULL the ECB:
  - ECB - LIGHTNING DETECT SYS (R AFT Bus)
- (6) Verify that a LIGHTNING DETECT FAIL CAS message is displayed.
- (7) On the MFD ECB AVIONICS synoptic page, reset the ECB:
  - ECB - LIGHTNING DETECT SYS (R AFT Bus)
- (8) On the PFD WXR tab select the CELL option for the Stormscope.  
Refer to [Fig. 504](#)
  - (a) Verify that the Strike Rate is displayed on the PFDs ('+' shaped symbols may also be displayed on the HSI, if lightning is present).
- (9) Depress the right LSK #4 to set the Stormscope mode to STRIKE.
  - (a) Verify that the Strike Rate is displayed on the PFDs ('x' shaped symbols may also be displayed on the HSI, if lightning is present).
- (10) On either PFD, tune the VHF 1 COMM radio to a test frequency (e.g., 123.450 MHz).
  - (a) Select COM 1 as the ACTIVE radio (if not already selected).

- (11) Key the pilot's Comm mic switch (transmit on VHF 1 Comm) repeatedly.
  - (a) Verify no strike data appears on the PFDs as a result of keying the VHF 1 transmitter.
- (12) On either PFD, tune the VHF 2 COMM radio to a test frequency (e.g., 123.450 MHz).
  - (a) Select COM 2 as the ACTIVE radio.
- (13) Key the co-pilot's Comm mic switch (transmit on VHF 2 Comm) repeatedly.
  - (a) Verify no strike data appears on the PFDs as a result of keying the VHF 2 transmitter.
- (14) Verify aircraft is positioned so that it can be freely turned 45° ( $\pm 5^\circ$ ) clockwise (to the right).
  - (a) Make sure area around aircraft is clear.
  - (b) Make sure that WX-PA tester can be moved with the aircraft.
  - (c) Make sure adequate cable is deployed from the external power cart to allow the aircraft to turn 45° to the right.
- (15) Power up the WX-PA Portable Analyzer unit.
  - After the WX-PA completes self-test, the MODE MENU will be displayed.
- (16) On the WX-PA, select "Continuous Out" on the MODE MENU, then press the MENU/ENTR button once (so that WX-PA indicates "PAUSED" and not "RUNNING").
- (17) On the WX-PA, press the FLAPS/A button to select top mount antenna configuration.
- (18) On the WX-PA, select a cardinal bearing of 0° and a range of 55 NM. Refer to TEST - 1 in [Table 502](#).
  - Use F1 and F2 buttons to adjust range and the F3 and F4 buttons to adjust bearing.
- (19) On the WX-PA, with "Continuous Out" still selected on the MODE MENU, press the MENU/ENTR button once so that WX-PA indication changes from "PAUSED" to "RUNNING".
- (20) On the PFD, press the STRIKE CLEAR LSK.
  - Strike data cleared from PFDs, then begins building again.

- (21) Verify that the Strike Rate is displayed on the PFDs.
- (a) When Strike Rate reaches approximately  $580 \pm 40$  strikes per minute, verify that the strikes appear within the required bearing limits for each of the settings on the WX-PA as shown in [Table 502](#).

**NOTE:** Strikes may appear approximately at half of the range selected on the PFD.

**NOTE:** Press the STRIKE CLEAR LSK after each test.

**Table 502. Cardinal Bearings Tests**

<b>TEST - 1</b> • Set WX-PA range = 55 NM • Set PFD range = 160 NM		<b>Result</b> (PASS/FAIL)
Set WX-PA bearing = 000°	Verify the displayed bearing = $000 \pm 10^\circ$	
Set WX-PA bearing = 090°	Verify the displayed bearing = $090 \pm 10^\circ$	
Set WX-PA bearing = 180°	Verify the displayed bearing = $180 \pm 10^\circ$	
Set WX-PA bearing = 270°	Verify the displayed bearing = $270 \pm 10^\circ$	
<b>TEST - 2</b> • Set WX-PA range = 30 NM • Set PFD range = 80 NM		<b>Result</b> (PASS/FAIL)
Set WX-PA bearing = 000°	Verify the displayed bearing = $000 \pm 10^\circ$	
Set WX-PA bearing = 090°	Verify the displayed bearing = $090 \pm 10^\circ$	
Set WX-PA bearing = 180°	Verify the displayed bearing = $180 \pm 10^\circ$	
Set WX-PA bearing = 270°	Verify the displayed bearing = $270 \pm 10^\circ$	
<b>TEST - 3</b> • Set WX-PA range = 15 NM • Set PFD range = 40 NM		<b>Result</b> (PASS/FAIL)
Set WX-PA bearing = 000°	Verify the displayed bearing = $000 \pm 10^\circ$	
Set WX-PA bearing = 090°	Verify the displayed bearing = $090 \pm 10^\circ$	
Set WX-PA bearing = 180°	Verify the displayed bearing = $180 \pm 10^\circ$	
Set WX-PA bearing = 270°	Verify the displayed bearing = $270 \pm 10^\circ$	

- (22) On the WX-PA, press 2<sup>nd</sup>, then press MENU/ENTR to return to Main Menu.
- (23) On the WX-PA, select “Continuous Out” on the MODE MENU, then press the MENU/ENTR button once (so that WX-PA indicates “PAUSED” and not “RUNNING”).
- (24) On the WX-PA, press the FLAPS/A button to select top mount antenna configuration (if not already selected).
  - WX-PA displays “Top Mnt”.
- (25) On the WX-PA, select a cardinal bearing of 180° and a range of 75 NM.
  - Use F1 and F2 buttons to adjust range and the F3 and F4 buttons to adjust bearing.
- (26) On the WX-PA, with “Continuous Out” still selected on the MODE MENU, press the MENU/ENTR button once so that WX-PA indication changes from “PAUSED” to “RUNNING”.
- (27) On the PFD, press the STRIKE CLEAR LSK.
  - Strike data cleared from PFDs, then begins building again.
- (28) Verify that the Strike Rate is displayed on the PFDs.
  - Strike RATE will show 600 ± 200 strikes per minute.
- (29) Test strikes appearing on the PFDs are at approximately 180 ± 10° relative and 75 NM.
- (30) With aircraft magnetic heading active, turn the aircraft 45 ± 5° clockwise, or to the right.
- (31) Older test strikes on PFDs are at approximately 135 ± 30° relative and 75 NM. Newer strikes displaying at approximately 180 ± 10° relative and 75 NM. Each newer test strike during the turn forms part of an approximately 45° “arc” pattern, from approximately 135° relative to approximately 180° relative.
- (32) Power down the WX-PA Portable Analyzer unit and remove WX-PA test set and antenna from aircraft.
- (33) If no other work is to be performed, turn OFF the aircraft power by setting the SYS BATT and START BATT Switches to the OFF (down) position and BUS TIE to OPEN (down) position.
- (34) Install 331 DT - Upper Over Fin Fairing. Refer to [AMM-55-10-12-041-801 – Overfin Fairing - Installation](#).

## 5. Procedure – Upper Over Fin Fairing – INSTALLED –

SUBTASK AMM-34-40-50-071-B-701-002

### A. Test Set-Up

#### **IMPORTANT!**

If for any reason the WX-PA tester produces "double image" lightning strikes on the PFD display, where the programmed strike pattern appears and additional strikes appear on a reciprocal bearing (180° away), then the Upper Over Fin Fairing must be removed. Refer to [SUBTASK AMM-34-40-50-071-B-701-001](#).

**NOTE:** The operator should be familiar with the WX-PA Portable Analyzer Kit.

- (1) Make sure all aircraft power is off.
- (2) Attach the WX-PA test set's antenna to the LDS NY-163 antenna.
  - (a) Position the WX-PA antenna on the LDS antenna as shown in [Fig. 501](#).
    - If necessary, use tape to secure WX-PA antenna; see [Fig. 502](#).
  - (b) Be sure to align the forwards arrows and position the WX-PA antenna suction cups forward of center along the longitudinal axis.
  - (c) Attach antenna cable grounding clip to nearby structure to obtain a good ground. See also [Fig. 503](#).
- (3) Route the WX-PA antenna cable away from the aircraft.
  - (a) Connect the antenna cable to the WX-PA test box.
  - (b) DO NOT POWER UP THE TEST SET.
- (4) On the IPL, set the SYS BATT and START BATT Switches to the ON (up) position and BUS TIE to AUTO (up) position.
  - (a) Clear any "MASTER CAUTIONS" and "MASTER WARNINGS" as needed.
  - (b) On the MFD, press the PROCEED Line Select Key (LSK).
- (5) Verify that no CAS messages are displayed indicating Lightning equipment failures.
- (6) On the MFD ECB AVIONICS synoptic page, PULL the ECB:
  - ECB - LIGHTNING DETECT SYS (R AFT Bus)
- (7) Verify that a LIGHTNING DETECT FAIL CAS message is displayed.
- (8) On the MFD ECB AVIONICS synoptic page, reset the ECB:
  - ECB - LIGHTNING DETECT SYS (R AFT Bus)
- (9) On the PFD WXR tab select the CELL option for the Stormscope.  
Refer to [Fig. 504](#)
  - (a) Verify that the Strike Rate is displayed on the PFDs ('+' shaped symbols may also be displayed on the HSI, if lightning is present).

- (10) Depress the right LSK #4 to set the Stormscope mode to STRIKE.
  - (a) Verify that the Strike Rate is displayed on the PFDs ('x' shaped symbols may also be displayed on the HSI, if lightning is present).
- (11) On either PFD, tune the VHF 1 COMM radio to a test frequency (e.g., 123.450 MHz).
  - (a) Select COM 1 as the ACTIVE radio (if not already selected).
- (12) Key the pilot's Comm mic switch (transmit on VHF 1 Comm) repeatedly.
  - (a) Verify no strike data appears on the PFDs as a result of keying the VHF 1 transmitter.
- (13) On either PFD, tune the VHF 2 COMM radio to a test frequency (e.g., 123.450 MHz).
  - (a) Select COM 2 as the ACTIVE radio.
- (14) Key the co-pilot's Comm mic switch (transmit on VHF 2 Comm) repeatedly.
  - (a) Verify no strike data appears on the PFDs as a result of keying the VHF 2 transmitter.
- (15) Verify aircraft is positioned so that it can be freely turned 45° ( $\pm 5^\circ$ ) clockwise (to the right).
  - (a) Make sure area around aircraft is clear.
  - (b) Make sure that WX-PA tester can be moved with the aircraft.
  - (c) Make sure adequate cable is deployed from the external power cart to allow the aircraft to turn 45° to the right.
- (16) Power up the WX-PA Portable Analyzer unit.
  - After the WX-PA completes self-test, the MODE MENU will be displayed.
- (17) On the WX-PA, select "Continuous Out" on the MODE MENU, then press the MENU/ENTR button once (so that WX-PA indicates "PAUSED" and not "RUNNING").
- (18) On the WX-PA, press the FLAPS/A button to select top mount antenna configuration.
- (19) On the WX-PA, select a cardinal bearing of 0° and a range of 55 NM. Refer to TEST - 1 in [Table 503](#).
  - Use F1 and F2 buttons to adjust range and the F3 and F4 buttons to adjust bearing.
- (20) On the WX-PA, with "Continuous Out" still selected on the MODE MENU, press the MENU/ENTR button once so that WX-PA indication changes from "PAUSED" to "RUNNING".
- (21) On the PFD, press the STRIKE CLEAR LSK.
  - Strike data cleared from PFDs, then begins building again.

- (22) Verify that the Strike Rate is displayed on the PFDs.
- (a) When Strike Rate reaches approximately  $580 \pm 40$  strikes per minute, verify that the strikes appear within the required bearing limits for each of the settings on the WX-PA as shown in [Table 503](#).

**NOTE:** Strikes may appear approximately at half of the range selected on the PFD.

**NOTE:** Press the STRIKE CLEAR LSK after each test.

**Table 503. Cardinal Bearings Tests**

<b>TEST - 1</b> • Set WX-PA range = 55 NM • Set PFD range = 160 NM		<b>Result</b> (PASS/FAIL)
Set WX-PA bearing = 000°	Verify the displayed bearing = $000 \pm 10^\circ$	
Set WX-PA bearing = 090°	Verify the displayed bearing = $090 \pm 10^\circ$	
Set WX-PA bearing = 180°	Verify the displayed bearing = $180 \pm 10^\circ$	
Set WX-PA bearing = 270°	Verify the displayed bearing = $270 \pm 10^\circ$	
<b>TEST - 2</b> • Set WX-PA range = 30 NM • Set PFD range = 80 NM		<b>Result</b> (PASS/FAIL)
Set WX-PA bearing = 000°	Verify the displayed bearing = $000 \pm 10^\circ$	
Set WX-PA bearing = 090°	Verify the displayed bearing = $090 \pm 10^\circ$	
Set WX-PA bearing = 180°	Verify the displayed bearing = $180 \pm 10^\circ$	
Set WX-PA bearing = 270°	Verify the displayed bearing = $270 \pm 10^\circ$	
<b>TEST - 3</b> • Set WX-PA range = 15 NM • Set PFD range = 40 NM		<b>Result</b> (PASS/FAIL)
Set WX-PA bearing = 000°	Verify the displayed bearing = $000 \pm 10^\circ$	
Set WX-PA bearing = 090°	Verify the displayed bearing = $090 \pm 10^\circ$	
Set WX-PA bearing = 180°	Verify the displayed bearing = $180 \pm 10^\circ$	
Set WX-PA bearing = 270°	Verify the displayed bearing = $270 \pm 10^\circ$	

- 
- (23) On the WX-PA, press 2<sup>nd</sup>, then press MENU/ENTR to return to Main Menu.
  - (24) On the WX-PA, select “Continuous Out” on the MODE MENU, then press the MENU/ENTR button once (so that WX-PA indicates “PAUSED” and not “RUNNING”).
  - (25) On the WX-PA, press the FLAPS/A button to select top mount antenna configuration (if not already selected).
    - WX-PA displays “Top Mnt”.
  - (26) On the WX-PA, select a cardinal bearing of 180° and a range of 75 NM.
    - Use F1 and F2 buttons to adjust range and the F3 and F4 buttons to adjust bearing.
  - (27) On the WX-PA, with “Continuous Out” still selected on the MODE MENU, then press the MENU/ENTR button once so that WX-PA indication changes from “PAUSED” to “RUNNING”.
  - (28) On the PFD, press the STRIKE CLEAR LSK.
    - Strike data cleared from PFDs, then begins building again.
  - (29) Verify that the Strike Rate is displayed on the PFDs.
    - Strike RATE will show 600 ± 200 strikes per minute.
  - (30) Test strikes appearing on the PFDs are at approximately 180 ± 10° relative and 75 NM.
  - (31) With aircraft magnetic heading active, turn the aircraft 45 ± 5° clockwise, or to the right.
  - (32) Older test strikes on PFDs are at approximately 135 ± 30° relative and 75 NM. Newer strikes displaying at approximately 180 ± 10° relative and 75 NM. Each newer test strike during the turn forms part of an approximately 45° “arc” pattern, from approximately 135° relative to approximately 180° relative.
  - (33) Power down the WX-PA Portable Analyzer unit and remove WX-PA test set and antenna from aircraft.
- B. Connect an External Battery Pack to the aircraft EXTERNAL POWER RECEPTACLE and turn on power. Ensure the green EXT POWER light on the IPL is on, but do not turn on aircraft’s power. Refer to [AMM-24-40-00-051-801 – External Power - Maintenance Practices](#).

**6. Job Close-Up**

SUBTASK AMM-34-40-50-071-B-921-002

- A. If no other work is to be performed, turn off the aircraft power by setting the SYS BATT and START BATT Switches to the OFF (down) position, and the BUS TIE to OPEN (down) position.
- B. If there are no other requirements for External Power, disconnect External Battery Pack from the aircraft EXTERNAL POWER RECEPTACLE.
- C. Install (if removed) 331 DT - Upper Overfin Fairing. Refer to [AMM-06-50-00-051-801 – Aircraft Access Panels](#) for location and installation instructions.
- D. Remove all tools, equipment, and unwanted material from work area. If all other maintenance is complete, return aircraft to service. Refer to [AMM-20-00-02-051-801 – Return To Service \(After Maintenance\)](#).

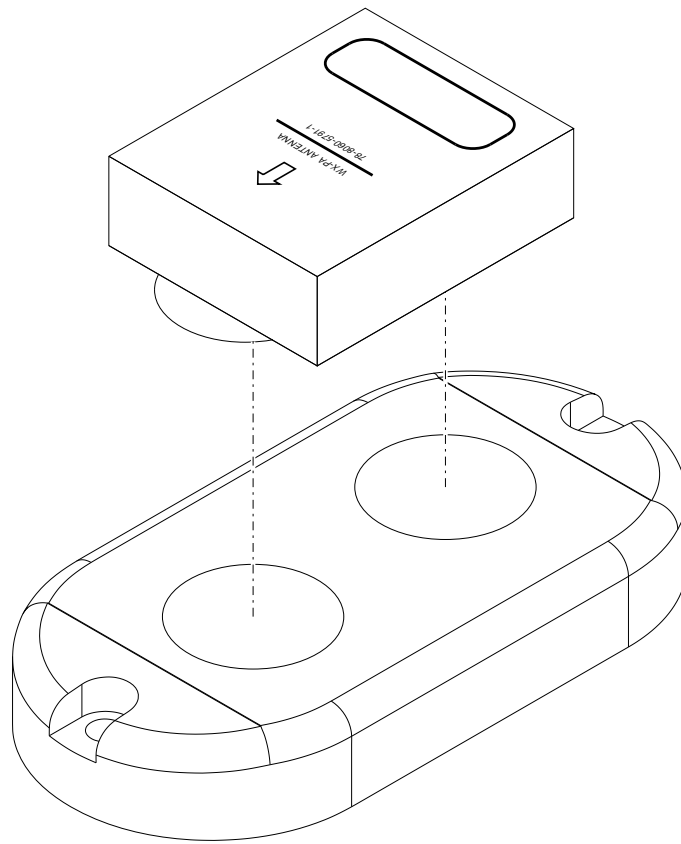

5131784A

**WX-PA Antenna Alignment**  
**Figure 501 (Sheet 1 of 1)**

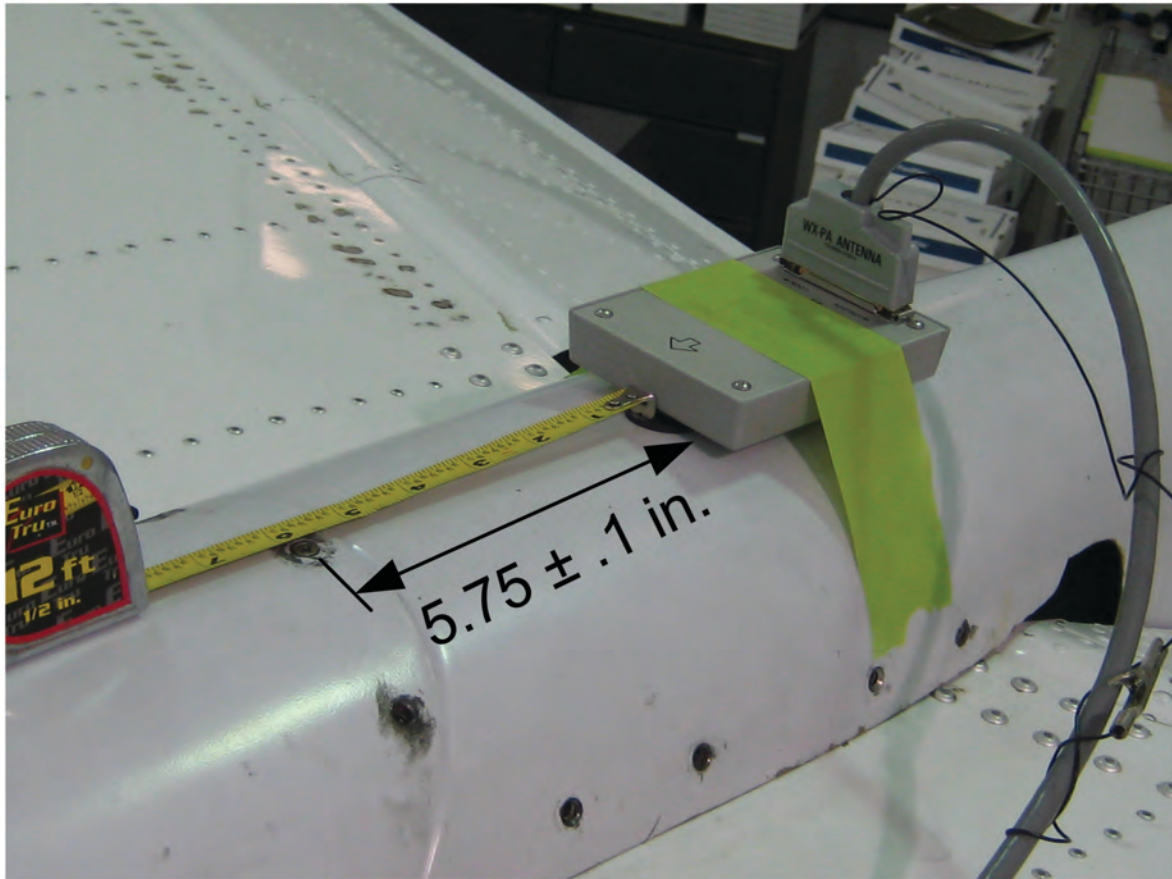

**Positioning the WX-PA Antenna on the Over Fin Fairing  
Figure 502 (Sheet 1 of 1)**

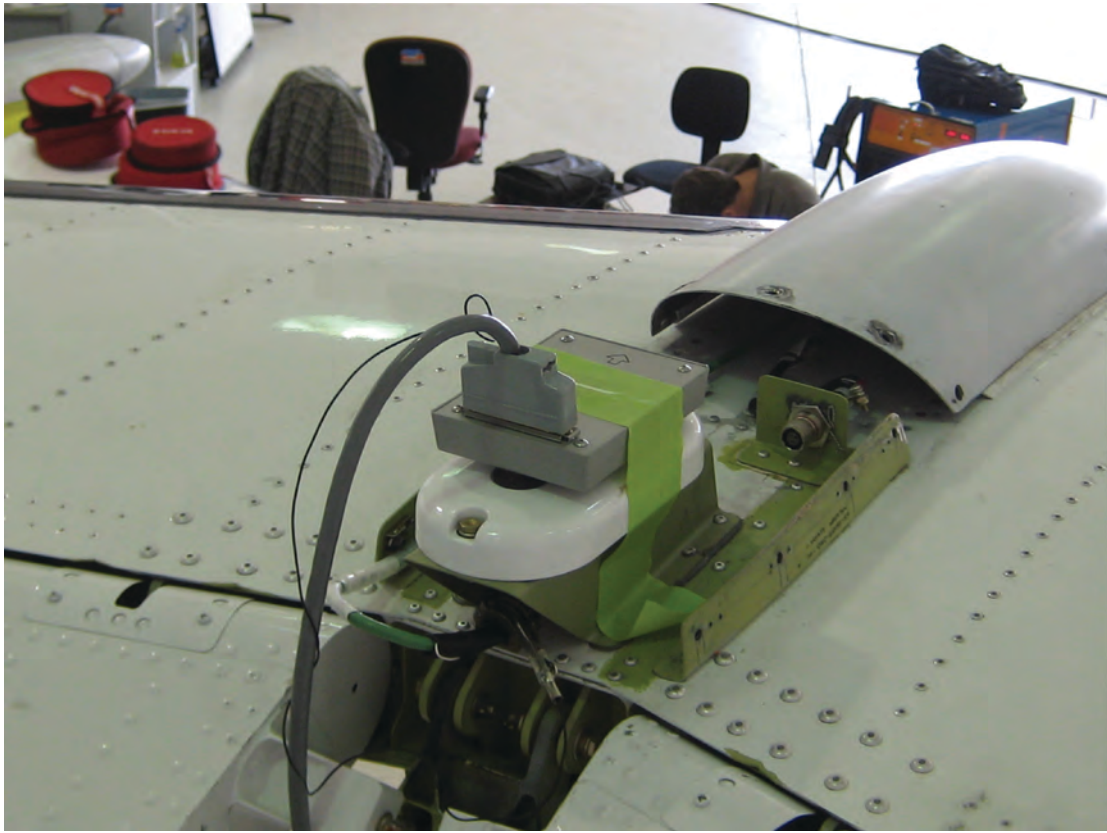

**WX-PA Antenna Attachment  
Figure 503 (Sheet 1 of 1)**



**PFD Stormscope Overlay (Cell Mode / Strike Mode)**  
**Figure 504 (Sheet 1 of 1)**

---

## **GPS - DESCRIPTION AND OPERATION**

AMM-34-50-10-081-B-801

### **1. Introduction**

- A. Global Positioning System/Wide Area Augmentation System (GPS/WAAS) is a U.S. satellite-based navigational, positioning and time transfer system operated by the Department of Defense (DOD). The GPS system provides highly accurate position and velocity information and precise time on a continuous global basis to an unlimited number of properly-equipped users. The system is unaffected by weather and provides a worldwide common grid reference system based on a world fixed coordinate system. GPS operation is based on the concept of ranging and triangulation from a group of 24 satellites in space which act as precise reference points. A minimum of five satellites are always observable by a user anywhere on earth. A GPS receiver measures distance from a satellite using the travel time of a radio signal. The GPS receiver needs at least four satellites to yield a three-dimensional position (latitude, longitude and altitude). It also yields time solutions for navigational values such as distance and bearing to a way point and ground speed.
- B. The GPS system is made up of the components that follow, refer to [Fig. 1](#).
- Two GPS antennas (Combination Antennas)
  - Two GPS 400W units
- C. Garmin GPS 400W
- (1) The GPS 400W has an internal GPS receiver, a 240 by 128 pixel color LCD display and a re-moveable data card containing a Jeppesen data base. It presents an active flight plan and moving map on its display and provides guidance and status display on its LCD and outputs guidance, flight plan and status data to external devices.
  - (2) The GPS 400W has a WAAS GPS engine that is TSO C146a certified for primary domestic, oceanic and remote navigation including en route, terminal and non-precision approaches and approaches with vertical guidance, such as LPV and LNAV/VNAV (when connected to an antenna of appropriate standard).
  - (3) The two GPS 400Ws function as autonomous units and can, in principle, have different active flight plans. However a serial data bus interface between two units enables a "cross fill" function that permits the two GPS 400W units to directly communicate and, depending on the crossfill mode selected, to have their active flight plans synchronized continuously or with pilot action. This allows one pilot to build or modify a flight plan on one GPS without affecting active navigation to the other GPS and when, the crew is satisfied, crossfill to synchronize the flight plans in the two units. Alternatively, one crew member can update the active flight plan knowing that the other GPS is continuously reflecting the changes that were made.

## 2. Description

SUBTASK AMM-34-50-10-081-B-871-001

### A. Garmin GPS 400W

- (1) The left-side GPS 400W is referred to as “GPS 1” and the right side GPS 400W installed will be called “GPS 2”.

If ADS-B function is installed, both GPS units are configured to output ADS-B OUT GPS position data in the Garmin model GTX33 transponder compatible format. This requires both GPS units to be at a specific software level as noted in the configuration procedures that follow.

**NOTE:** Only GPS 1 has RS-232 interface with XPDR 1. ADS-B OUT data is then broadcast using XPDR 1 only.

### B. Physical Installation

- (1) Two GPS 400W units are installed as standard equipment in the location formerly occupied by the left and right keyboard.
- (2) The aft combo antenna is connected to the right GPS 400W (“GPS 2”) and the forward combo antenna is connected to the left GPS 400W (“GPS 1”).

## 3. Operation

SUBTASK AMM-34-50-10-081-B-871-002

**NOTE:** Refer to [AMM-34-50-10-051-A-801 – GPS - Maintenance Practices](#) for general operating information and instructions for configuring the unit to the aircraft.

- A. Two GPS antennas (Combination Antennas) and two GPS/WAAS units make up the GPS system on this aircraft. The GPS processes signals from satellites to give the position of the aircraft and to calculate navigation and flight data.
- B. GPS 400W Standby Altitude/Airspeed Indication ( Standby Indication and Electrical Provisions Package Option)
  - (1) If the optional Standby Indication and Electrical Provisions Package (i.e., GPS 400W Standby Altitude/Airspeed Indication) is installed, then an additional and independent display of altitude and airspeed is provided. The Left GPS 400W will display "IND ALT" and "CAS", actually KEAS as provided by ADC 3 through the ACS. The ADC3 data is displayed on the Left GPS 400W AUX page group, Flight Planning page, Density Alt / TAS / Winds selection.

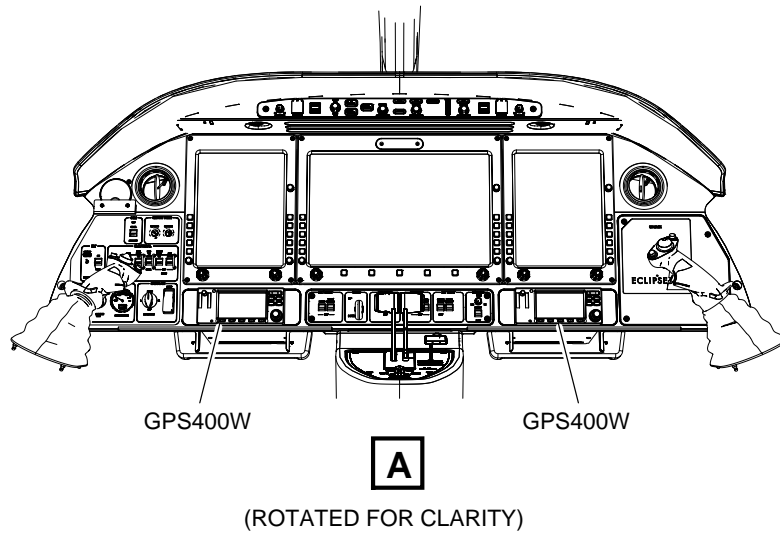
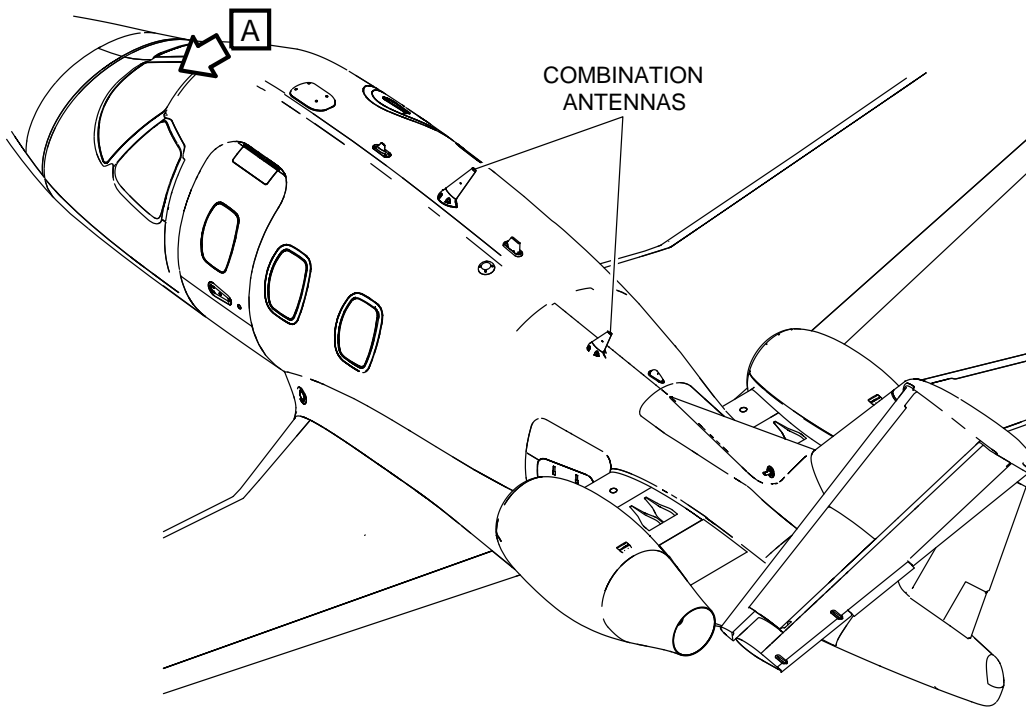

**GPS — Combination Antenna Location**  
**Figure 1 (Sheet 1 of 1)**

5080778A

THIS PAGE INTENTIONALLY LEFT BLANK

## GPS - MAINTENANCE PRACTICES

AMM-34-50-10-051-A-801

### **1. General**

- A. The purpose of this task is to provide instructions for configuring the GPS 400W for use on the Eclipse Model 500 aircraft.
- B. If ADS-B OUT is installed, GPS software must be at least at the following level:  
 SW P/N 006-B1144-23 Main SW v5.03  
 SW P/N 006-B0803-20 GPS WAAS SW v5.0.

**NOTE:** As applicable, make sure that the GPS software is in same configuration as it was when the removal task was completed. If necessary, update GPS software to the required level.

### **2. Equipment and Materials**

**Table 201. Special Tools and Equipment**

Name and Part Number
Ground Power Unit (GPU) (AllStar 450, AllStar G.S.E., Hobart GPU-400, Hobart GPU- 600, or Bycan PS-28100)
Weight-on-Wheels (WOW) Box (EAI, 87-117390-1001) or AMC 2.4.01 (or higher).

### **3. Job Set-Up**

SUBTASK AMM-34-50-10-051-A-921-001

- A. Make aircraft safe for maintenance. Refer to [AMM-20-00-01-051-801 – Make Safe For Maintenance](#).
- B. Connect the ground power cart to electrical utility connector. Connect the ground power cart to the aircraft EXTERNAL POWER RECEPTACLE and turn on power on the cart. Ensure the green EXT POWER light on the IPL is on. But do not turn on aircraft's power. Refer to [AMM-24-40-00-051-801 – External Power - Maintenance Practices](#).
- C. Connect Weight On Wheels (WOW) box or Aircraft Maintenance Computer (AMC) and set to W-On-W for start of test. Refer to [AMM-20-00-04-051-801 – Weight On Wheels \(WOW\) Box - Connect/Disconnect](#).
- D. On the IPL set the SYS BATT and START BATT switches to the ON (up) position and BUS TIE to AUTO (up) position. On the right side of the MFD, press the PROCEED soft key. Clear any "MASTER CAUTIONS" and "MASTER WARNINGS" as needed.
- E. On the ECB AVIONICS synoptic page. Make sure the following ECBs are AUTO-ON:
  - ECB - GPS 1 (R FWD Bus) or
  - ECB - GPS 2 (L FWD Bus)

- F. Make sure the following circuit breakers in the pilot's and co-pilot's armrest (Com-Jack Panels) are engaged:
- MECHANICAL CIRCUIT BREAKER - CIRCUIT BREAKER BOX LEFT, XPDR1/GPS1 (or) MECHANICAL CIRCUIT BREAKER - CIRCUIT BREAKER BOX LEFT, XPDR1/GPS1/ATT3
  - MECHANICAL CIRCUIT BREAKER - CIRCUIT BREAKER BOX RIGHT, XPDR2/GPS2

#### 4. **General Operating Information**

SUBTASK AMM-34-50-10-051-A-701-001

(Refer to [Fig. 201.](#))

##### A. Power

- (1) Each GPS 400W has its own power knob in the upper left corner. The power knob has an on/off detent; the range of knob rotation clockwise from the detent has no effect on operation. This power control is in series with aircraft power.

##### B. Menus

- (1) In normal operating mode, the lower right corner of the display indicates the current page group and page. The large right knob may be used to change page group among NAV, WPT, AUX, and NRST, while the small right knob may be used to select a page within the page group. Other page groups are available via dedicated keys: DRCT, MSG, FPL and PROC. The NAV page group may be accessed directly by pressing and holding CLR.

##### C. Entering or Changing Data

- (1) In most cases, entering data or changing a parameter or selection requires a cursor, represented by an inverse flashing block. The cursor is turned on when the small right knob is pressed. When the cursor is on, the large right knob generally changes moves the cursor from field to field and the small right knob generally changes data or selections. The cursor may be dismissed by pressing the small right knob again (although more than one small right knob press may be required if more than one selection level deep).
- (2) Data entry is usually committed using ENT, or cancelled using the CLR.

## 5. Procedure

SUBTASK AMM-34-50-10-051-A-701-002

**NOTE:** This configuration procedure is for one GPS 400W unit. However, both installed GPS 400W units must be configured. Differences in the configuration of the left and right GPS 400W units are indicated in the procedure.

### A. Power On and Reset GPS 400W.

**CAUTION:** HANDLE THE DATA CARDS CAREFULLY. DO NOT TOUCH THE CONNECTOR EDGE OF THE DATA CARD. DO NOT INSTALL OR REMOVE A DATA CARD WHILE THE GPS 400W IS ON.

- (1) Make sure the GPS 400W has the Nav Database (left slot) and Terrain Database (right slot) data cards installed. The Nav Database data card is labeled IFRW, and the Terrain Database card is labeled TAWS/TERRAIN DATA. Database cards should be installed with the label facing left.
- (2) Rotate the GPS 400W power knob fully counter-clockwise past the detent to the off position.
- (3) Make sure aircraft is safe for power.
- (4) On the Left Instrument Panel, set START BATT, BUS TIE, and SYS BATT switches to ON. Clear any "MASTER CAUTIONS" and "MASTER WARNINGS" as needed.
- (5) On the ECB AVIONICS synoptic page, ensure ECB - GPS 1 (L FWD Bus) and ECB - GPS 2 (R FWD Bus) are AUTO/ON. Make sure the circuit breakers in the pilot's and co-pilot's armrest (Com-Jack Panels ) MECHANICAL CIRCUIT BREAKER - CIRCUIT BREAKER BOX LEFT, XPDR1/GPS1 (or) MECHANICAL CIRCUIT BREAKER - CIRCUIT BREAKER BOX LEFT, XPDR1/GPS1/ATT3 and MECHANICAL CIRCUIT BREAKER - CIRCUIT BREAKER BOX RIGHT, XPDR2/GPS2 are engaged.
- (6) While pressing CLR, rotate the GPS 400W power knob clockwise past the detent to the ON position. Continue to hold CLR until the display comes on. Pressing and holding CLR while powering on the GPS 400W gives the option to reset the GPS 400W to its default configuration.
- (7) The GPS 400W will display the following:
  - "INITIALIZING SYSTEM"
  - "DO YOU WANT TO CLEAR USER SETTINGS"
  - "?"
  - "PRESS CLR FOR NO AND ENT FOR YES"
  - "NO ASSUMED IN x SECONDS"
- (8) Press ENT within ten seconds of the appearance of the display shown in step 7.
- (9) The GPS 400W will display the following:
  - "CLEARING USER SETTINGS"(followed by the following display)

- “CONTINUING IN x SECONDS”
- (10) After approximately one minute, the GPS 400W will start Self Test. Several screens of information will be displayed. When a flashing OK? is displayed, press ENT.
  - (11) The INSTRUMENT PANEL SELF-TEST screen is displayed, with a flashing OK?. Press ENT.
  - (12) Rotate the GPS 400W power knob fully counter-clockwise, past the detent to the OFF position. Wait for GPS 400W screen to go off.
- B. Enter Configuration Mode.
- (1) While pressing ENT, rotate the GPS 400W power knob clockwise past the detent to the on position. Continue to hold ENT until the display comes on. Pressing and holding ENT while powering on the GPS 400W places the unit in configuration mode.
  - (2) After powering on, the GPS 400W will start Self Test. Several screens of information will be displayed. When a flashing OK? is displayed, press ENT.
  - (3) The INSTRUMENT PANEL SELF-TEST screen is displayed, with a flashing OK?. Press ENT.
  - (4) MAIN ARINC 429 CONFIG screen should be displayed. If it is not, rotate the power knob to the off position, wait for the unit to power off, and repeat section B.
- C. Configure ARINC 429 Interfaces.
- (1) ARINC 429 interface configuration is performed on the MAIN ARINC 429 CONFIG page. Different configuration screens may be selected using the small right knob while in configuration mode.
  - (2) While on the MAIN ARINC 429 CONFIG screen, press the small right knob to turn on the cursor. The cursor may be moved to different fields by rotating the large right knob.
  - (3) With the cursor at the IN 1 / SPEED field, rotate the small right knob to select Low. Press ENT.
  - (4) With the cursor at the IN 1 / DATA field, rotate the small right knob to select EFIS / Airdata Press ENT. For aircraft configured for (Standby Indication and Electrical Provisions Package option), on the L GPS400W select Off. Press ENT.
    - For left GPS 400W on aircraft NOT configured for (Standby Indication and Electrical Provisions Package option), rotate the small right knob to select EFIS / Airdata. Press ENT. If the EFIS / Airdata selection is grayed out (not selectable), select OFF and return to this field to select EFIS / Airdata after other fields on the page have been configured
    - For the Right GPS 400W, regardless of configuration, rotate the small right knob to select EFIS / Airdata. Press ENT. If the EFIS / Airdata selection is grayed out

(not selectable), select OFF and return to this field to select EFIS / Airdata after other fields on the page have been configured.

**NOTE:** Note 1 in [Fig. 202](#). For left GPS 400W, on aircraft configured for (Standby Indication and Electrical Provisions Package option), enter: "Off"; for aircraft NOT configured for (Standby Indication and Electrical Provisions Package option) or right GPS 400W, enter: "EFIS / Airdata". Example shows left GPS 400W on aircraft not configured for European operations.

- (5) In this same manner, set IN 2 / SPEED to Low, IN 2 / DATA to Off, OUT / SPEED to High, and OUT / DATA to GAMA 429 Grph w/ Int.
  - (6) Set SDI to Common and VNAV to Enable Labels.
  - (7) The MAIN ARINC 429 CONFIG screen settings should now match the settings in [Fig. 202](#).
  - (8) Press the small right knob to dismiss the cursor. The small right knob may now be rotated to select other configuration screens.
- D. Configure RS-232 Interfaces.
- (1) Determine whether the aircraft has the Stormscope option installed. This will be indicated by the LIGHTNING STRIKE DETECTION option being displayed on the MFD or PFD INSTALLED EQUIPMENT list. The INSTALLED EQUIPMENT list may be accessed on the MFD or PFD via the SETUP tab, selecting SETTINGS, then selecting INSTALLED EQUIPMENT.
  - (2) On the GPS 400W, rotate small right knob to select MAIN RS232 CONFIG page.
  - (3) Press the small right knob to turn on the cursor.
  - (4) Using the large right knob to select fields as necessary, the small right knob to make selections, and ENT to confirm selections, set up the RS-232 configuration as shown in [Fig. 203](#).
    - (a) Use the following settings for CHNL 2 INPUT:
      - 1 "Off" for left GPS 400W on aircraft NOT configured for the (Standby Indication and Electrical Provisions Package option).
      - 2 "Shadin-adc" ("In" only; "out" is "off") for left GPS 400W on aircraft configured for the (Standby Indication and Electrical Provisions Package option). Refer to [Fig. 221](#) for example of modification.
      - 3 "Off" for right GPS 400W regardless of configuration.
    - (b) If ADS-B OUT is installed, use the following settings for CHNL 2 OUTPUT:  
 CHNL 2/OUTPUT = ADS-B OUT+
 

**NOTE:** For this configuration selection to be available, GPS software must be at least at the following level:  
 SW P/N 006-B1144-23 Main SW v5.03  
 SW P/N 006-B0803-20 GPS WAAS SW v5.0.

**NOTE:** If applicable, make sure that the GPS software is in same configuration as it was when the removal task was completed. If necessary, update GPS software to the required level.

(c) Use the following settings for CHNL 4 INPUT and OUTPUT:

- 1 “WX-500” for left GPS 400W on Stormscope-equipped aircraft (INPUT and OUTPUT).
- 2 “Off” for left GPS 400W on aircraft not equipped with Stormscope (INPUT and OUTPUT).
- 3 “Off” for right GPS 400W regardless of Stormscope installation (INPUT and OUTPUT).

**NOTE:** Note 1 in [Fig. 203](#). For left GPS 400W, and Stormscope equipped aircraft, enter: “WX-500”; for non- Stormscope equipped aircraft or right GPS 400W, enter: “Off”. Example shows Left GPS 400W with a Stormscope installed.

**NOTE:** Note 2 in [Fig. 203](#). For left GPS 400W, on aircraft configured for (Standby Indication and Electrical Provisions Package option), enter: “Shadin-adc”; for aircraft NOT configured for (Standby Indication and Electrical Provisions Package option) or right GPS 400W, enter: “Off”. Example shows left GPS 400W on aircraft NOT configured for (Standby Indication and Electrical Provisions Package option).

(5) If a cursor is still displayed, press the small right knob to dismiss it.

E. Configure Main System Configuration Items.

- (1) Rotate small right knob to select MAIN SYSTEM CONFIG page.
- (2) Press the small right knob to turn on the cursor.
- (3) With the cursor at the CONFIGURE field, rotate the small right knob to select Fuel. Press ENT.
- (4) With the cursor at the FUEL TYPE field, rotate the small right knob to select Jet A. Press ENT.
- (5) The MAIN SYSTEM CONFIG – Fuel screen settings should now match the data entered in [Fig. 204](#).
- (6) Rotate the large right knob to place the cursor in the CONFIGURE field. Rotate the small right knob to select Terrain. Press ENT.
- (7) With the cursor at the TERRAIN TYPE field, rotate the small right knob to select NONE. Press ENT.
- (8) Rotate the large right knob to place the cursor on TEST CARD?. Press ENT. The TEST CARD? field will display Testing... and the percent counter will count up to 100%.
  - If the TEST CARD? field displays No Card or something other than PASS after the percent counter reaches 100%, power off the GPS 400W and check installation and seating of the Terrain Database card. Restart this procedure from section B.

**CAUTION:** HANDLE THE DATA CARDS CAREFULLY. DO NOT TOUCH THE CONNECTOR EDGE OF THE DATA CARD. DO NOT INSTALL OR REMOVE A DATA CARD WHILE THE GPS 400W IS ON.

- (9) The MAIN SYSTEM CONFIG – Terrain screen settings should now match the data entered in [Fig. 205](#).
  - (10) Rotate the large right knob to place the cursor in the CONFIGURE field. Rotate the small right knob to select Discretes. Press ENT.
  - (11) With the cursor at the GPS SELECT field, rotate the small right knob to select Auto. Press ENT.
  - (12) The MAIN SYSTEM CONFIG – Discretes screen settings should now match the data entered in [Fig. 206](#).
  - (13) If a cursor is still displayed, press the small right knob to dismiss it.
- F. Check Inputs from PFD.
- (1) Rotate small right knob to select MAIN INPUTS 1 page.
  - (2) Verify data displayed on MAIN INPUTS 1 screen is per notes in [Fig. 207](#).
    - Note 1 matches heading displayed on same-side PFD
    - Note 2 matches OAT displayed on same-side PFD
    - Note 3 within 10 ft of altitude displayed on same-side PFD
  - (3) Any discrepancy in the values as described by the notes indicates the GPS 400W was not configured correctly in previous steps, or there is a communication problem between the PFD and the GPS 400W. This should be resolved before proceeding with the remaining procedures.
- G. Configure Backlighting.
- (1) Rotate small right knob to select MAIN LIGHTING page.
  - (2) Press the small right knob to turn on the cursor.
  - (3) Using the large right knob to select fields as necessary, the small right knob to make selections and enter values, and ENT to confirm selections, set up the MAIN LIGHTING configuration as shown in [Fig. 208](#).
- H. Configure Antenna Offset
- (1) Rotate small right knob to select GPS VERTICAL OFFSET page.
  - (2) Press the small right knob to turn on the cursor.
  - (3) Turn small right knob to select value of 6.0 feet as shown in [Fig. 209](#).
  - (4) If a cursor is still displayed, press the small right knob to dismiss it.
- I. Check Inputs From Stormscope (Option).
- NOTE:** This step applies to the Stormscope option and to the left GPS 400W only. Skip this step if these conditions do not apply.
- (1) Rotate small right knob to select STORMSCOPE CONFIG page.

- 
- (2) Verify communication with Stormscope by confirming STORMSCOPE CONFIG page appears as shown in [Fig. 210](#). If page appears different from [Fig. 210](#), re-check settings in section C., and Stormscope installation and communication.
- J. Configure User Settings on AUX Pages.
- (1) Rotate the GPS 400W power knob fully counter-clockwise, past the detent to the off position. Wait for GPS 400W screen to go off, then rotate the power knob clockwise past the detent to the on position.
  - (2) After powering on, the GPS 400W will start Self Test. Several screens of information will be displayed. When a flashing OK? is displayed, press ENT.
  - (3) The INSTRUMENT PANEL SELF-TEST screen is displayed, with a flashing OK?. Press ENT.
  - (4) A page from the NAV page group will be displayed (either the Map page or the Satellite Status page). Rotate the large right knob until the AUX page group indication is displayed in the lower right corner of the GPS 400W display. Refer to [Fig. 211, Sheet 1](#) (Figure 2).
  - (5) While on the first page of the AUX page group, press the small right knob to turn on the cursor. Rotate the large right knob to select Crossfill and press ENT.
  - (6) Using the large right knob to select fields as necessary, the small right knob to make selections, and ENT to confirm selections, set up the CROSSFILL configuration as shown in [Fig. 211, Sheet 2](#).
  - (7) Press the small right knob to return to the first AUX page after CROSSFILL configuration is set. Press the small right knob again to dismiss the cursor on AUX page 1.
  - (8) Rotate the small right knob to select the third page of the AUX page group (SETUP 1).
  - (9) While on the SETUP 1 page, press the small right knob to turn on the cursor. Press ENT to select Airspace Alarms.
  - (10) Using the large right knob to select fields as necessary, the small right knob to make selections and enter values, and ENT to confirm selections, set up the AIRSPACE ALARMS configuration as shown in [Fig. 212](#).
  - (11) Press the small right knob to return to the SETUP 1 page after AIRSPACE ALARMS configuration is set.
  - (12) Rotate the large right knob to select CDI / Alarms and press ENT.
  - (13) Using the large right knob to select fields as necessary, the small right knob to make selections and enter values, and ENT to confirm selections, set up the CDI / ALARMS configuration as shown in [Fig. 213](#).
  - (14) Press the small right knob to return to the SETUP 1 page after CDI / ALARMS configuration is set.
  - (15) Rotate the large right knob to select Units / Mag Var and press ENT.
  - (16) Using the large right knob to select fields as necessary, the small right knob to make selections, and ENT to confirm selections, set up the UNITS / MAG VAR configuration as shown in [Fig. 214](#).

- (17) Press the small right knob to return to the SETUP 1 page after UNITS / MAG VAR configuration is set.
- (18) Rotate the large right knob to select Position / Map Datum and press ENT.
- (19) Using the large right knob to select fields as necessary, the small right knob to make selections, and ENT to confirm selections, set up the POSITION FORMAT / MAP DATUM configuration as shown in [Fig. 215](#).
- (20) Press the small right knob to return to the SETUP 1 page after POSITION FORMAT / MAP DATUM configuration is set.
- (21) Rotate the large right knob to select Date / Time and press ENT.
- (22) Using the large right knob to select fields as necessary, the small right knob to make selections and enter values, and ENT to confirm selections, set up the DATE / TIME configuration as shown in [Fig. 216](#).
- (23) Press the small right knob to return to the SETUP 1 page after DATE / TIME configuration is set. Press the small right knob again to dismiss the cursor on SETUP 1.
- (24) Rotate the small right knob to select the fourth page of the AUX page group (SETUP 2).
- (25) While on the third page of the SETUP 2 page, press the small right knob to turn on the cursor. Press ENT to select DISPLAY.
- (26) Using the large right knob to select fields as necessary, the small right knob to make selections and enter values, and ENT to confirm selections, set up the DISPLAY configuration as shown in [Fig. 217](#).
- (27) Press the small right knob to return to the SETUP 2 page after DISPLAY configuration is set.
- (28) Rotate the large right knob to select Nearest Airport Criteria and press ENT.
- (29) Using the large right knob to select fields as necessary, the small right knob to make selections, and ENT to confirm selections, set up the NEAREST AIRPORT CRITERIA as shown in [Fig. 218](#).
- (30) Press the small right knob to return to the SETUP 2 page after NEAREST AIRPORT CRITERIA configuration is set.
- (31) Rotate the large right knob to select SBAS Selection and press ENT.
- (32) Using the large right knob to select fields as necessary, the small right knob to make selections, and ENT to confirm selections, set up the SBAS SELECTION configuration as shown in [Fig. 219](#).
- (33) Press the small right knob to return to the SETUP 2 page after SBAS SELECTION configuration is set.
- (34) Rotate the large right knob to select Data Field Configuration and press ENT.
- (35) Using the large right knob to select fields as necessary, the small right knob to make selections, and ENT to confirm selections, set up the DATA FIELD CONFIGURATION as shown in [Fig. 220](#).

- 
- (36) Press the small right knob to return to the SETUP 2 page after DATA FIELD CONFIGURATION configuration is set. Press the small right knob again to dismiss the cursor on SETUP 2.

## 6. **Job Close-Up**

### SUBTASK AMM-34-50-10-051-A-921-002

- A. Power down the GPS 400W units. Rotate the GPS 400W power knob fully counter-clockwise past the detent to the off position.
- B. Remove all tools, equipment, and unwanted material from work area.
- C. If no other work is to be performed, turn off the aircraft power by setting the SYS BATT and START BATT Switches to the OFF (down) position and BUS TIE to OPEN (down) position.
- D. If no other requirements for External Power, Power down the GPU. Disconnect the GPU from the aircraft EXTERNAL POWER RECEPTACLE on the aircraft. Disconnect the GPU from the electrical utility connector.
- E. If not previously accomplished, disconnect Weight On Wheels (WOW) box or Aircraft Maintenance Computer (AMC). Refer to [AMM-20-00-04-051-801 – Weight On Wheels \(WOW\) Box - Connect/Disconnect](#).
- F. If all other maintenance is complete, return aircraft to service. Refer to [AMM-20-00-02-051-801 – Return To Service \(After Maintenance\)](#).



**GPS 400W Panel – Layout  
Figure 201 (Sheet 1 of 1)**



**GPS 400W Panel – MAIN ARINC 429 CONFIG Settings**  
**Figure 202 (Sheet 1 of 1)**

MAIN RS232 CONFIG		
	INPUT	OUTPUT
CHNL 1	off	HW EGPWS
CHNL 2	off (Note 2)	off
CHNL 3	Crossfill	Crossfill
CHNL 4	WX-500 (Note 1)	WX-500 (Note 1)

**GPS 400W Panel – MAIN RS232 CONFIG Settings  
Figure 203 (Sheet 1 of 1)**

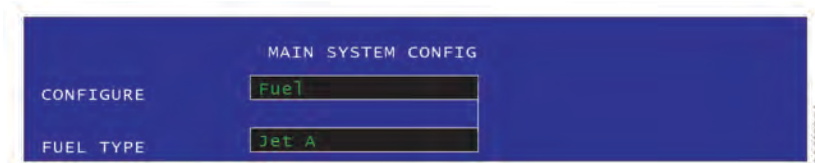

**GPS 400W Panel – MAIN SYSTEM CONFIG – Fuel Settings  
Figure 204 (Sheet 1 of 1)**

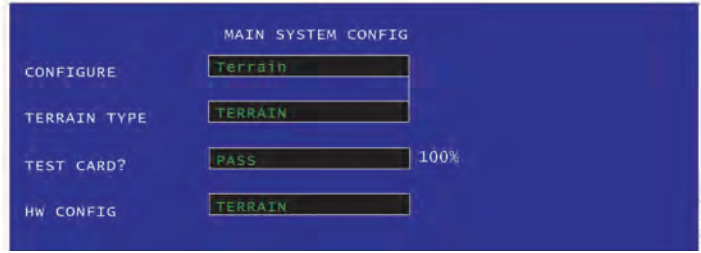

**GPS 400W Panel – MAIN SYSTEM CONFIG – Terrain Settings  
Figure 205 (Sheet 1 of 1)**

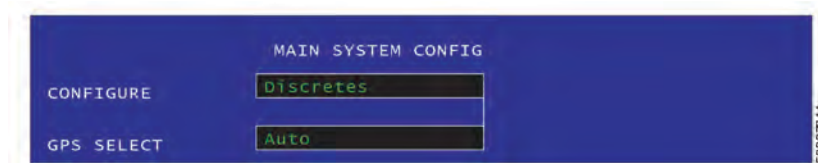

**GPS 400W Panel – MAIN SYSTEM CONFIG – Discrettes Settings  
Figure 206 (Sheet 1 of 1)**

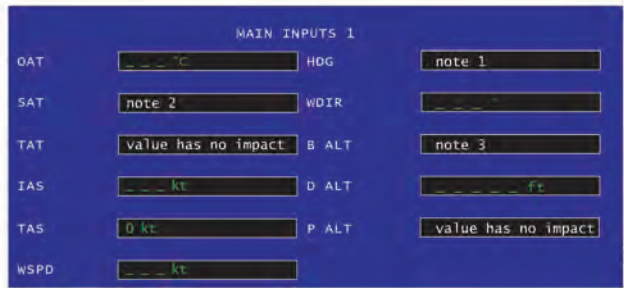

**GPS 400W Panel – MAIN INPUTS 1 Display  
Figure 207 (Sheet 1 of 1)**



**GPS 400W Panel – MAIN LIGHTING Settings  
Figure 208 (Sheet 1 of 1)**

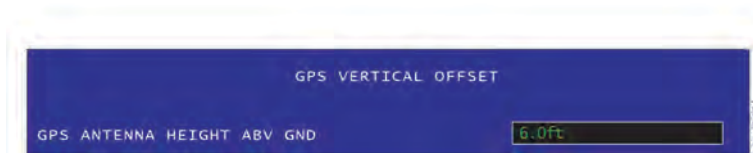

**GPS 400W Panel – GPS VERTICAL OFFSET Settings**  
**Figure 209 (Sheet 1 of 1)**

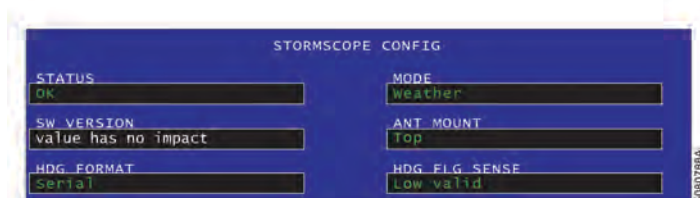

**GPS 400W Panel – STORMSCOPE CONFIG Settings**  
**Figure 210 (Sheet 1 of 1)**

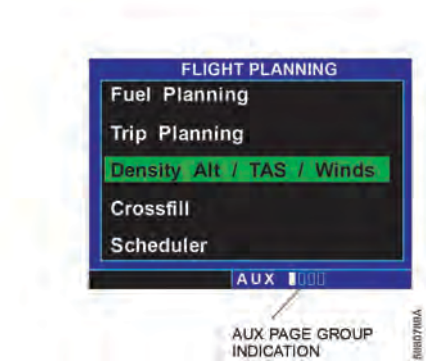

**GPS 400W Panel – AUX Page Group & CROSSFILL Settings  
Figure 211 (Sheet 1 of 2)**

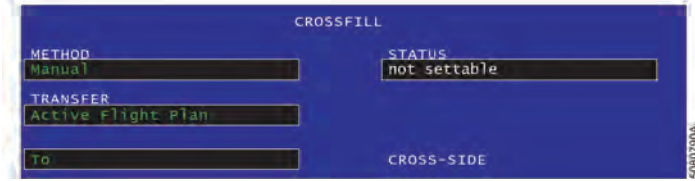

**GPS 400W Panel – AUX Page Group & CROSSFILL Settings  
Figure 211 (Sheet 2 of 2)**



The image shows a screenshot of the 'AIRSPACE ALARMS' settings menu on the GPS 400W panel. The menu is displayed on a dark background with white text. The title 'AIRSPACE ALARMS' is at the top. Below it, several settings are listed, each with a status indicator on the right. The settings are: CLASS B/TMA (on), CLASS C/TCA (on), CLASS D (ON), RESTRICTED (on), MOA (MILITARY) (on), and Altitude buffer (200ft). A vertical label 'V16/08/05' is visible on the right side of the screenshot.

AIRSPACE ALARMS	
CLASS B/TMA	on
CLASS C/TCA	on
CLASS D	ON
RESTRICTED	on
MOA (MILITARY)	on
Altitude buffer	200ft

**GPS 400W Panel – AIRSPACE ALARMS Settings  
Figure 212 (Sheet 1 of 1)**

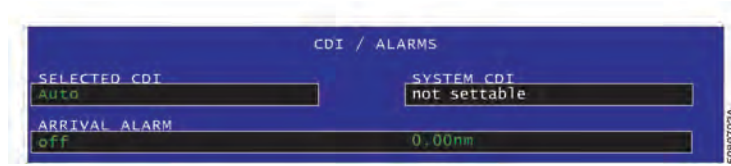

**GPS 400W Panel – CDI / ALARMS Settings**  
**Figure 213 (Sheet 1 of 1)**

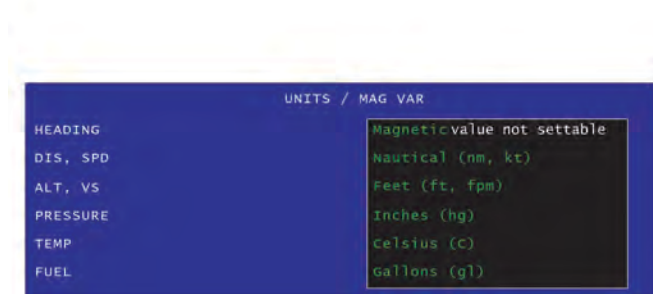

**GPS 400W Panel – UNITS / MAG VAR Settings  
Figure 214 (Sheet 1 of 1)**



**GPS 400W Panel – POSITION FORMAT / MAP DATUM Settings  
Figure 215 (Sheet 1 of 1)**

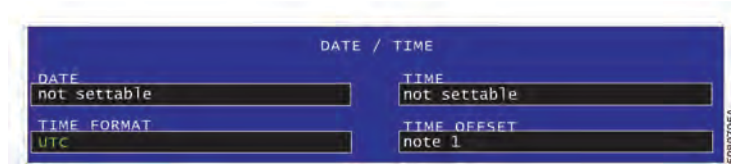

**GPS 400W Panel – DATE / TIME Settings**  
**Figure 216 (Sheet 1 of 1)**

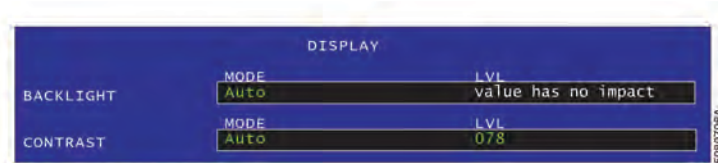

**GPS 400W Panel – DISPLAY Settings**  
**Figure 217 (Sheet 1 of 1)**



**GPS 400W Panel – NEAREST AIRPORT CRITERIA Settings**  
**Figure 218 (Sheet 1 of 1)**

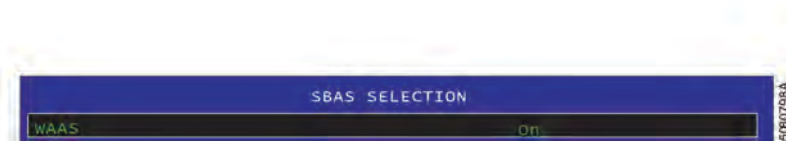

**GPS 400W Panel – SBAS SELECTION Settings  
Figure 219 (Sheet 1 of 1)**



**GPS 400W Panel – DATA FIELD CONFIGURATION Settings  
Figure 220 (Sheet 1 of 1)**

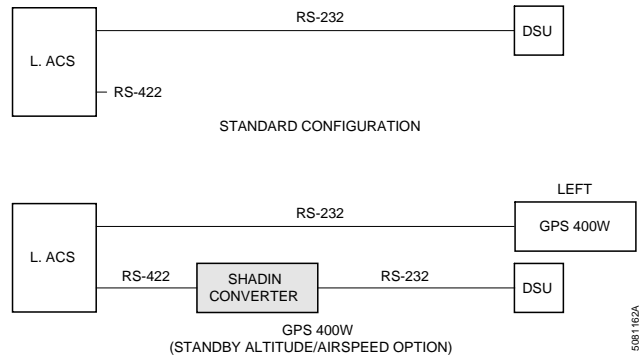

**GPS 400W – Standby Altitude/Airspeed Indication Option  
Figure 221 (Sheet 1 of 1)**

### GPS 3- MAINTENANCE PRACTICES

AMM-34-50-10-051-B-801

#### **1. General**

- A. The purpose of this task is to provide instructions for configuring GPS 3 (GDL 88) for use on the Eclipse Model 500 aircraft.

The following procedure must be performed on the bench with the Special Tools and Equipment listed below.

#### **2. Equipment and Materials**

**Table 201. Special Tools and Equipment**

Name & Part Number
Portable Power Supply capable of outputting 28 ± 0.5 VDC
GDL 88 Software Download Cable (87-125272-1001)
PC with Windows 7 SP 1
GDL 84/88 Install Tool ver 4.00, SW (006-A0248-20) [1]

- [1] This tool is subject to change by Garmin. Refer to GDL 88 Installation Manual (IM), 190-01122-00, for more information. Use the IM as general guidance or Garmin Dealer website which is a source for downloading Garmin software and tools for a particular product.

#### **3. Job Set-Up**

SUBTASK AMM-34-50-10-051-B-921-001

- A. Make aircraft safe for maintenance. Refer to [AMM-20-00-01-051-801 – Make Safe For Maintenance](#).

#### **4. Procedure**

SUBTASK AMM-34-50-10-051-B-701-002

- A. Perform the following configuration procedure.
- (1) Using PC, install the GDL 88 Configuration Tool per the instructions in the GDL 88 IM, 190-01122-00.
  - (2) Turn the power supply on and make sure the power supply is set to 28 ± 0.5 VDC. Turn the power supply off.
  - (3) Connect backplate of the GDL 88 software download cable to the unit. Make sure the 1090 MHz antenna (BTM) connector is terminated by the 50 ohm/5 watt terminator.
  - (4) Connect the GDL 88 software download cable, 87-125272-1001, to the power supply.

- (5) Connect the USB connector of the GDL 88 software download cable, 87-125272-1001, to the PC.
- (6) Turn the power supply on.
- (7) Run the GDL 8X Install Tool.  
**NOTE:** USB drivers automatically install and it might take a few minutes before Install Tool can connect to GDL 88.
- (8) Make sure the GDL 8x Install Tool interface window indicates the GDL 88 Connection Status in green color. Refer to [Fig. 201, Sheet 1](#).
- (9) Check or install the required hardware/software configuration of GDL 88 unit.  
**NOTE:** If necessary, perform the software installation per the appropriate Garmin Software Service Bulletin
- (10) On the GDL 8x Install Tool, select Diagnostics: Faults.  
Make sure that the faults are acceptable. For example, Position and Altitude faults are acceptable as the procedure takes place on the bench, and, therefore, there is no GPS antenna installed or Altitude is not yet supplied at the time of configuration.  
Refer to Garmin: 190-01310-00, GDL 84/88 Part 23 AML STC Installation Manual, for the Faults definitions and the respective corrective actions as required or contact Eclipse Service Engineering.
- (11) On the GDL 8x Install Tool, select Configuration: Aircraft. Refer to [Fig. 202, Sheet 1](#).  
Populate the following aircraft specifics:
  - Aircraft ICAO Address (Octal)
  - ADS-B Transmit: Disable
  - FIS-B Processing: Disable
  - Internal GPS/SBAS: Enable
  - Equipment Status Annunciations: Dual
- (12) On the GDL 8x Install Tool, select Configuration: Antenna. Refer to [Fig. 203, Sheet 1](#).  
Make sure Internal GPS/SBAS Antenna specifics are as shown in [Fig. 203, Sheet 1](#).
- (13) On the GDL 8x Install Tool, select Configuration: Audio.  
Set Output Method to None.
- (14) On the GDL 8x Install Tool, select Configuration: ARINC 429.  
Make sure all ports are disabled.
- (15) On the GDL 8x Install Tool, select Configuration: RS-232/RS-422.  
Make sure the ports' configuration is as shown in [Fig. 204, Sheet 1](#).
- (16) On the GDL 8x Install Tool, select Configuration: Ethernet.  
Make sure this configuration is as shown in [Fig. 205, Sheet 1](#).
- (17) Close Garmin GDL 84/88 Install Tool.
- (18) Cycle power to the GDL 88.
- (19) Repeat steps (8) through (17) to confirm set parameters.

- (20) Turn off power supply.
- (21) Disconnect GDL 88 from backplate.

#### **5. Job Close-Up**

SUBTASK AMM-34-50-10-051-B-921-002

- A. Remove all tools, equipment, and unwanted material from work area.

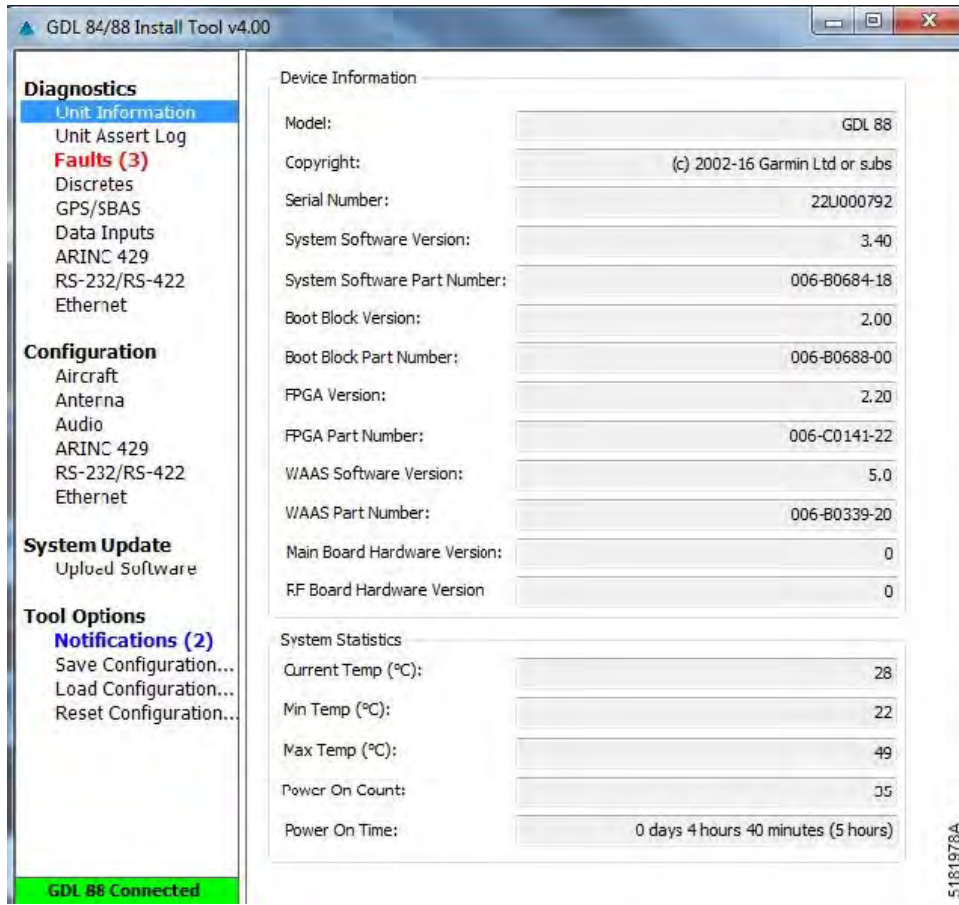

**GDL 8x Install Tool: Unit Information**  
**Figure 201 (Sheet 1 of 1)**

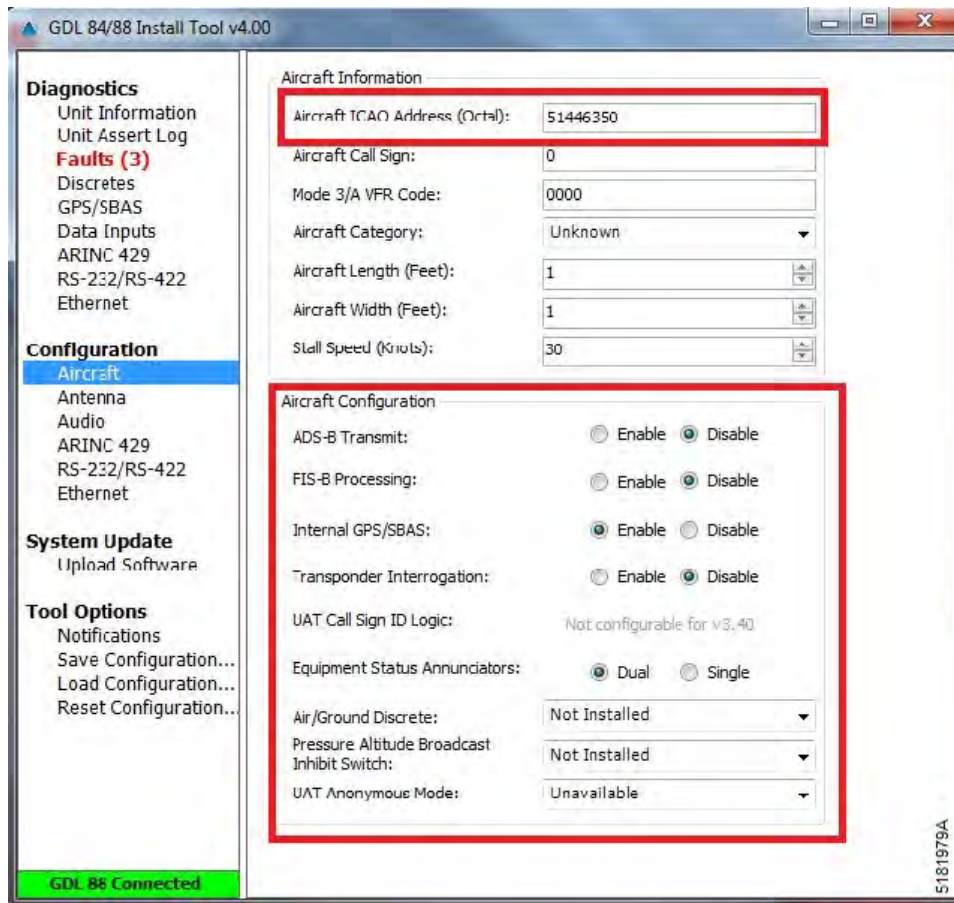

**GDL 8x Install Tool: Aircraft Configuration  
Figure 202 (Sheet 1 of 1)**

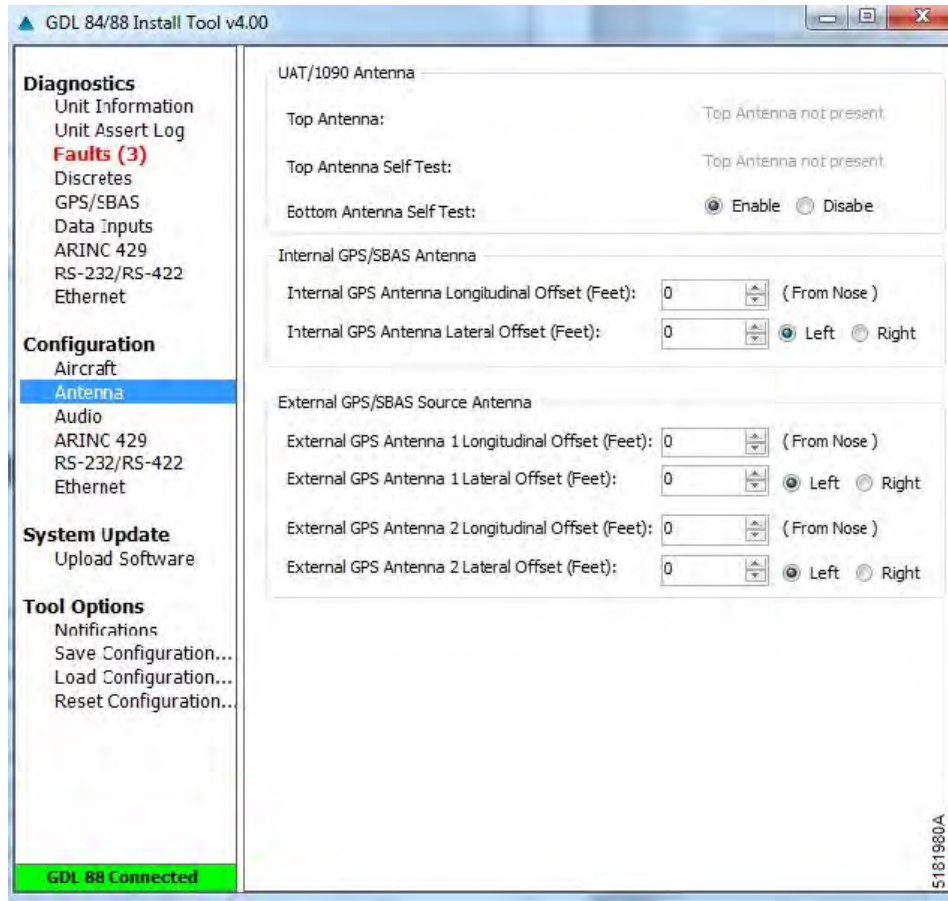

**GDL 8x Install Tool: Antenna Configuration**  
**Figure 203 (Sheet 1 of 1)**

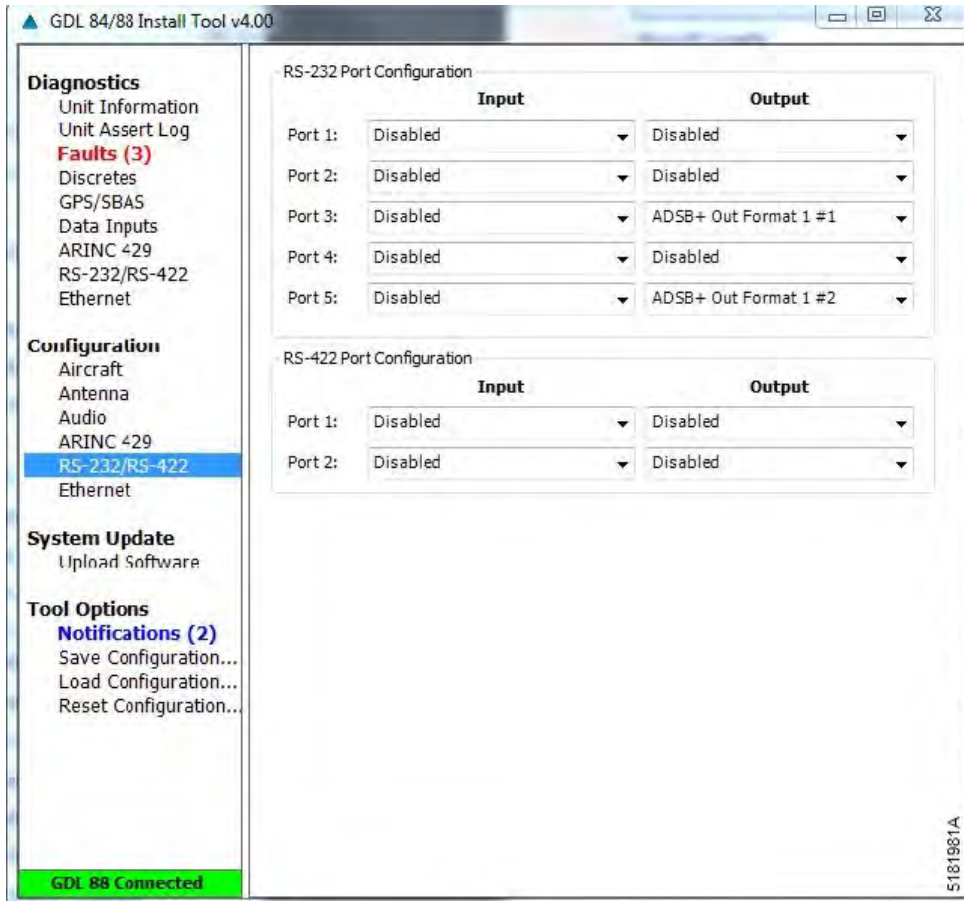

**GDL 8x Install Tool: RS-232/RS-422 Configuration**  
**Figure 204 (Sheet 1 of 1)**

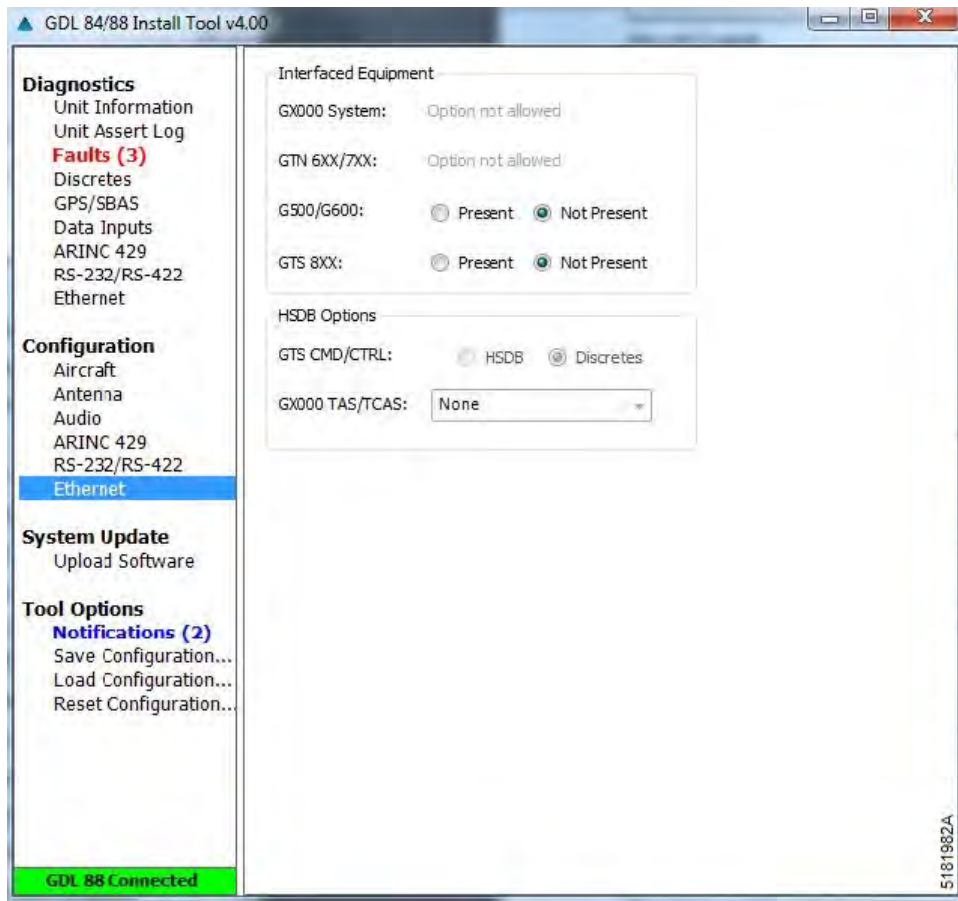

**GDL 8x Install Tool: Ethernet Configuration**  
**Figure 205 (Sheet 1 of 1)**

---

**GPS - ADJUSTMENT/TEST**

AMM-34-50-10-071-C-801

**1. General**

- A. This task gives procedures to do the adjustment/test of the Global Positioning System (GPS 1 & GPS 2) components.

**2. Job Set-Up**

SUBTASK AMM-34-50-10-071-C-921-001

- A. Make aircraft safe for maintenance. Refer to [AMM-20-00-01-051-801 – Make Safe For Maintenance](#).
- B. Connect external power. Refer to [AMM-24-40-00-051-801 – External Power - Maintenance Practices](#).

**3. MFD Set-Up**

SUBTASK AMM-34-50-10-071-C-701-001

- A. On the MFD system synoptic pages select the SETUP tab.
- B. Press the Sensors Line Select Key.
- C. Press the GPS Line Select Key. Confirm that both GPS receivers:
- display HPL, VPL, and VFOM information
  - indicate a STATUS of 3D WAAS
- D. Press the Satellite Status Line Select Key. Confirm that both GPS receivers are displaying satellite-status signal-strength information.
- E. On the other side of the MFD, select the system synoptic page ECB tab.

**4. GPS 1 Test**

SUBTASK AMM-34-50-10-071-C-801-002

- A. Do Job Set-Up. Refer to [SUBTASK AMM-34-50-10-071-C-921-001](#).
- B. Do MFD Set-Up. Refer to [SUBTASK AMM-34-50-10-071-C-701-001](#).
- C. On the MFD ECB page, ensure that the ECB - GPS 1 (R FWD Bus) and the ECB - INTEGRATED SENSOR 1 (BATT Bus) are AUTO-ON.
- D. On the MFD ECB page, pull ECB - GPS 1 (R FWD Bus). After 5 seconds, make sure that GPS 1 is displaying satellite-status information.
- E. On the MFD ECB page, reset ECB - GPS 1 (R FWD Bus).
- F. On the MFD ECB page, pull ECB - INTEGRATED SENSOR 1 (BATT Bus). After 5 seconds, make sure that GPS 1 is displaying satellite-status information.

- G. On the MFD ECB page, reset ECB - INTEGRATED SENSOR 1 (BATT Bus).

## **5. GPS 2 Test**

SUBTASK AMM-34-50-10-071-C-801-003

- A. Do Job Set-Up. Refer to [SUBTASK AMM-34-50-10-071-C-921-001](#).
- B. Do MFD Set-Up. Refer to [SUBTASK AMM-34-50-10-071-C-701-001](#).
- C. On the MFD ECB page, ensure that the ECB - GPS 2 (L FWD Bus) and the ECB - INTEGRATED SENSOR 2 (L AFT Bus) are AUTO-ON.
- D. On the MFD ECB page, pull ECB - GPS 2 (L FWD Bus). After 5 seconds, make sure that GPS 2 is displaying satellite-status information
- E. On the MFD ECB page, reset ECB - GPS 2 (L FWD Bus).
- F. On the MFD ECB page, pull ECB - INTEGRATED SENSOR 2 (L AFT Bus). After 5 seconds, make sure that GPS 2 is displaying satellite-status information.
- G. On the MFD ECB page, reset ECB - INTEGRATED SENSOR 2 (L AFT Bus).

## **6. Job Close-Up**

SUBTASK AMM-34-50-10-071-C-921-002

- A. Remove all tools, equipment, and unwanted material from work area.
- B. Disconnect external power. Refer to [AMM-24-40-00-051-801 – External Power - Maintenance Practices](#).
- C. If all other maintenance is complete, return aircraft to service. Refer to [AMM-20-00-02-051-801 – Return To Service \(After Maintenance\)](#).

---

**GPS 3- REMOVAL**

AMM-34-50-11-001-C-801

**1. General**

- A. This task gives procedures to remove the Global Positioning System (GPS 3) unit.
- B. There is one GPS 3 (GDL 88) installed on the aircraft under 131 CZ-B - Floor Panel, Aft Short, Left Cabin.

**2. Job Set-Up**

SUBTASK AMM-34-50-11-001-C-921-001

- A. Make aircraft safe for maintenance. Refer to [AMM-20-00-01-051-801 – Make Safe For Maintenance](#).
- B. Make sure all power is removed from the aircraft.

**3. Procedure**

SUBTASK AMM-34-50-11-001-C-011-001

(Refer to [Fig. 401](#).)

**CAUTION:** DO NOT REMOVE 131 CZ-B - FLOOR PANEL, AFT SHORT, LEFT CABIN. THE GPS 3 (GDL 88) MOUNT AND WIRING ARE ATTACHED TO THE UNDERSIDE OF THE FLOOR PANEL.

- A. Remove screws, but do not remove 131 CZ-B - Floor Panel, Aft Short, Left Cabin (3) . Refer to [AMM-25-11-30-001-801 – Cockpit Floor Panels - Removal](#) .
- B. Lift the forward edge and pivot 131 CZ-B - Floor Panel, Aft Short, Left Cabin (3) to access GDL 88 mounting knob (2) .
- C. Pull on the lock down lever knob (2) while loosening. Disengage locking lever away from GPS 3 (GDL 88) unit right angled hook.

**NOTE:** Pulling on the lever knob will disengage the locking teeth.

- D. Pull the GPS 3 (GDL 88) unit (1) straight out of the rack.

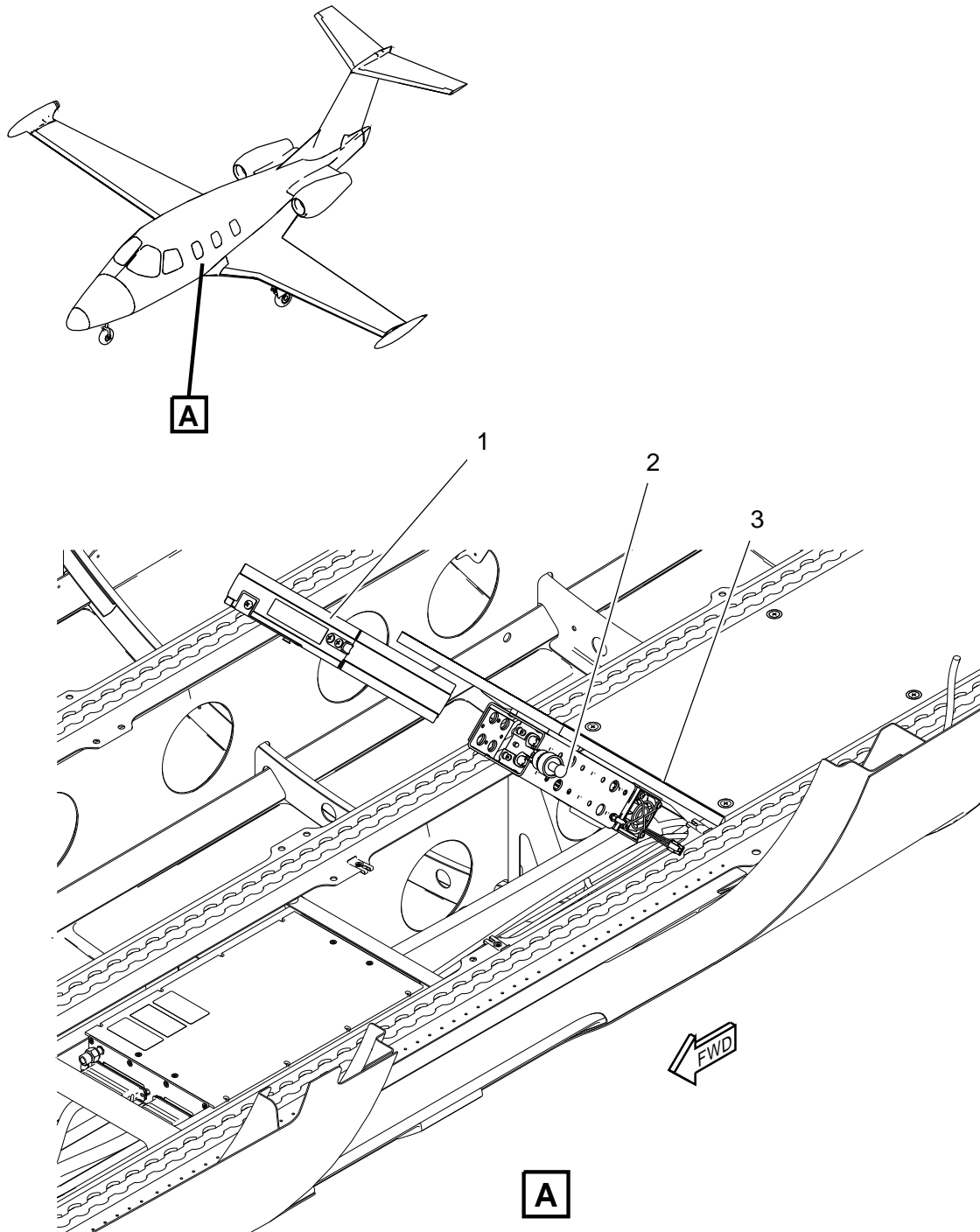

5181977A

**GPS 3- Removal/Installation**  
**Figure 401 (Sheet 1 of 1)**

---

## **GPS - REMOVAL**

AMM-34-50-11-001-D-801

### **1. General**

- A. This task gives the procedure to remove the Global Positioning System/Wide Area Augmentation System (GPS/WAAS) sensors.
- B. There are two GPS/WAAS sensors installed in the aircraft. Removal steps are the same for the light and right sides, unless specified.

### **2. Job Set-Up**

SUBTASK AMM-34-50-11-001-D-921-001

- A. Make the aircraft safe for maintenance. Refer to [AMM-20-00-01-051-801 – Make Safe For Maintenance..](#)
- B. Remove power from the aircraft. Refer to [AMM-24-40-00-051-801 – External Power - Maintenance Practices..](#)
- C. Remove the 231 JZ – Cabin Headliner Assembly. Refer to [AMM-06-50-00-051-801 – Aircraft Access Panels.](#)

### **3. Procedure**

SUBTASK AMM-34-50-11-001-D-011-001

(Refer to [Fig. 401.](#))

- A. Remove the four bolts (1) that attach the GPS/WAAS sensor (4) to the mounting bracket (5).
  - (1) For the right side sensor, remove the four spacers (6).
- B. Disconnect the electrical connector (2) and Coax Threaded Neill-Concelman (TNC) connector (3) from the GPS/WAAS sensor (4).
- C. Remove the GPS/WAAS sensor (4) from the mounting bracket (5).
- D. Install protective caps on the electrical connector (2) and Coax TNC connector (3).

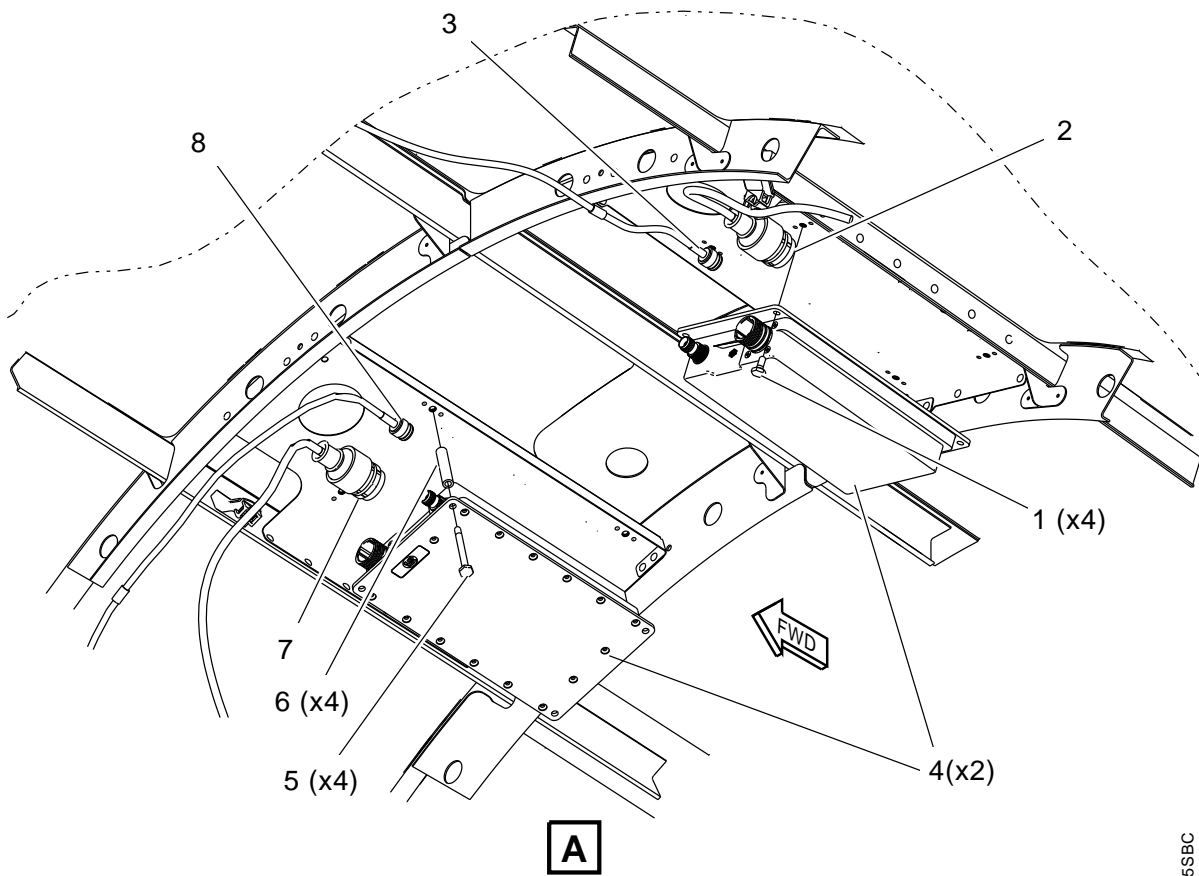
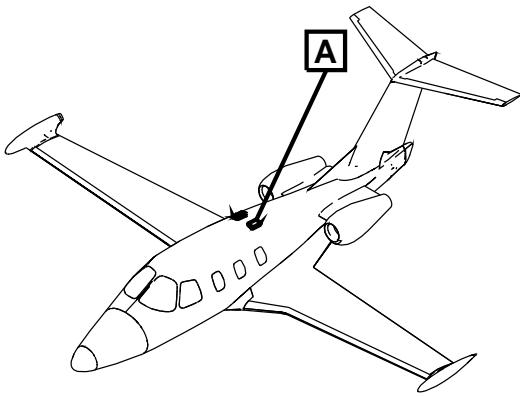

(ROTATED FOR CLARITY)

**GPS - Removal/Installation**  
**Figure 401 (Sheet 1 of 1)**

5A34051335SBC

## GPS - INSTALLATION

AMM-34-50-11-041-B-801

### **1. General**

- A. This task gives procedures to install the Global Positioning System/Wide Area Augmentation System (GPS/WAAS) Garmin GPS 400W Navigator.
- B. There are two GPS 400W units installed on the aircraft. Installation procedures are the same for both sides and given for the left side GPS 400W unit.

### **2. Equipment and Materials**

**Table 401. Special Tools and Equipment**

Name & Part Number
Generic Hex Drive Tool, 3/32 in (Commercially Available)

### **3. Job Set-Up**

SUBTASK AMM-34-50-11-041-B-921-001

- A. Make sure aircraft is in same configuration as it was when removal task was completed. Refer to [AMM-34-50-11-001-C-801 – GPS 3- Removal](#) .

### **4. Procedure**

SUBTASK AMM-34-50-11-041-B-411-001

(Refer to [Fig. 401.](#))

#### A. GPS Bracket Assembly Back Plate Installation:

- (1) If the back plate was previously removed, replace the back plate (5) by positioning the tabs on the back plate in the slots of the left side of the GPS bracket assembly (6) (viewing it from the cockpit) and attaching it by replacing the two screws (4) .
- (2) Remove protective caps on electrical connector (2) and Coax connector (3) .
- (3) Attach electrical connector (2) and Coax connector (3) .

#### B. GPS 400W Unit Insertion:

**NOTE:** If there is interference of the pawl locking assembly and the instrument panel, it may be necessary to use the 3/32- inch hex drive tool to rock the pawl assembly +/- 90 degrees while gently pushing (fwd) on the GPS 400W, in order to get the pawl assembly past the instrument panel.

- (1) After the pawl assembly clears the instrument panel, the GPS 400W unit (1) is installed in the GPS bracket assembly (6) by sliding it straight in until it stops, about 1 inch short of the final position. A 3/32- inch hex drive tool is then inserted into the

access hole at the bottom of the unit face. Rotate the hex tool clockwise while pressing on the left side of the bezel until the unit is firmly seated in the rack.

- (2) Be sure not to overtighten the unit into the GPS bracket assembly (6). The application of hex drive tool torque exceeding -15 lbf.in can damage the locking mechanism.

## 5. **Job Close-Up**

SUBTASK AMM-34-50-11-041-B-921-002

- A. Remove all tools, equipment, and unwanted material from work area.
- B. Close circuit breakers that follow:
- ECB - GPS 1 (R FWD Bus)
  - ECB - GPS 2 (L FWD Bus)
- C. Complete GPS 400W configuration (if not previously accomplished), refer to [AMM-34-50-10-051-801 – GPS - Maintenance Practices](#).
- D. Do an adjustment/test of the GPS. Refer to [AMM-34-50-10-071-C-801 – GPS - Adjustment/Test](#)  
If ADS-B function is installed, perform ADS-B Out Functional Test. Refer to [SUBTASK AMM-34-50-20-071-C-701-006](#)
- E. If all other maintenance is complete, return aircraft to service. Refer to [AMM-20-00-02-051-801 – Return To Service \(After Maintenance\)](#).

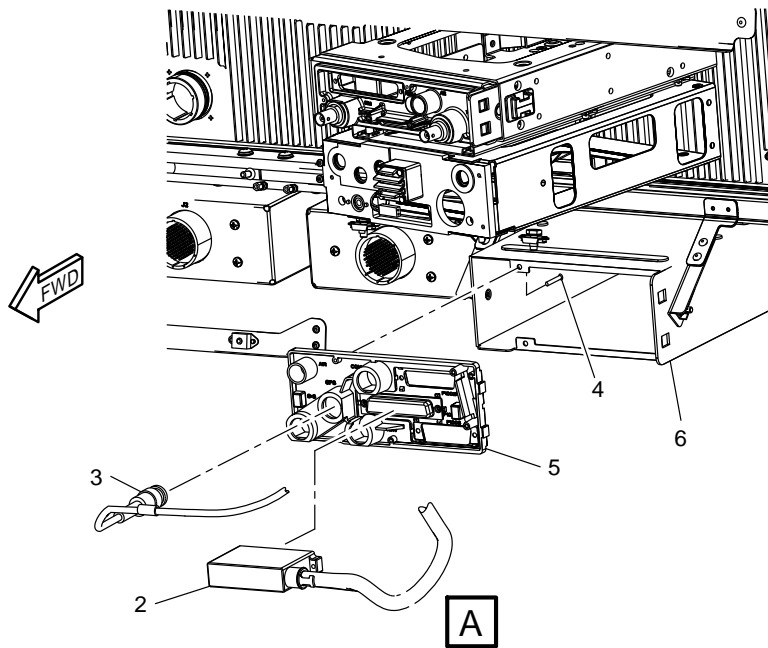
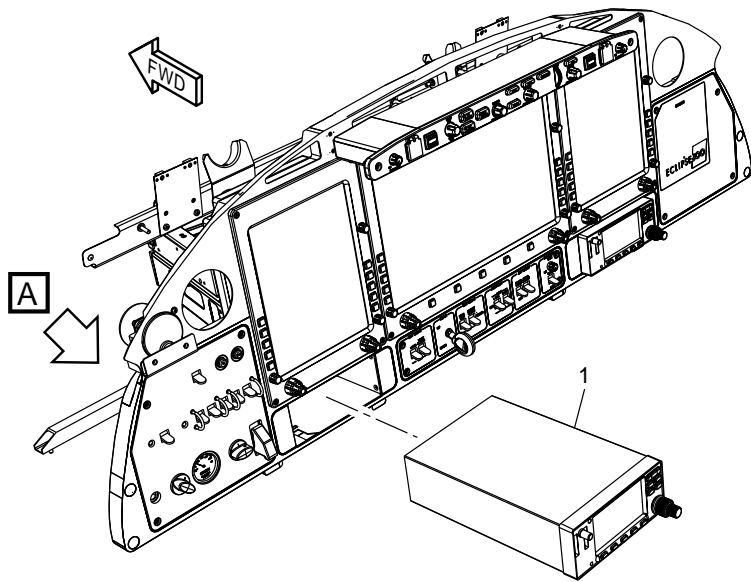

**NOTE:**  
STRUCTURE AND EQUIPMENT  
REMOVED FOR CLARITY

5080735B

**GPS - Removal/Installation**  
**Figure 401 (Sheet 1 of 1)**

THIS PAGE INTENTIONALLY LEFT BLANK

---

## **GPS 3 - INSTALLATION**

AMM-34-50-11-041-C-801

### **1. General**

- A. This task gives procedures to install the Global Positioning System (GPS 3) unit.
- B. There is one GPS 3 installed on the aircraft under 131 CZ-B - Floor Panel, Aft Short, Left Cabin.

### **2. Job Set-Up**

SUBTASK AMM-34-50-11-041-C-921-001

- A. Make sure aircraft is in same configuration as it was when removal task was completed. Refer to [AMM-34-50-11-001-C-801 – GPS 3- Removal](#) .
- B. Complete GPS 3 configuration (if not previously accomplished), refer to [AMM-34-50-10-051-B-801 – GPS 3- Maintenance Practices](#) .
- C. Make sure that mount backplate has the 50 ohm/5 watt termination load is installed on coax receptacle BTM.

### **3. Procedure**

SUBTASK AMM-34-50-11-041-C-411-001

(Refer to [Fig. 401.](#))

- A. Slide the GPS 3 unit [\(1\)](#) straight into the rack until it stops.
- B. Lift the lock down arm [\(2\)](#) over the right angled hook on the unit and hand tightened.
- C. Secure 131 CZ-B - Floor Panel, Aft Short, Left Cabin with four screws. Refer to [AMM-25-11-30-041-801 – Cockpit Floor Panels - Installation](#) .

### **4. Job Close-Up**

SUBTASK AMM-34-50-11-041-C-921-002

- A. Remove all tools, equipment, and unwanted material from work area.
- B. Do a system test of the ADS-B. Refer to [SUBTASK AMM-34-50-20-071-C-701-005](#).
- C. If all other maintenance is complete, return aircraft to service. Refer to [AMM-20-00-02-051-801 – Return To Service \(After Maintenance\)](#).

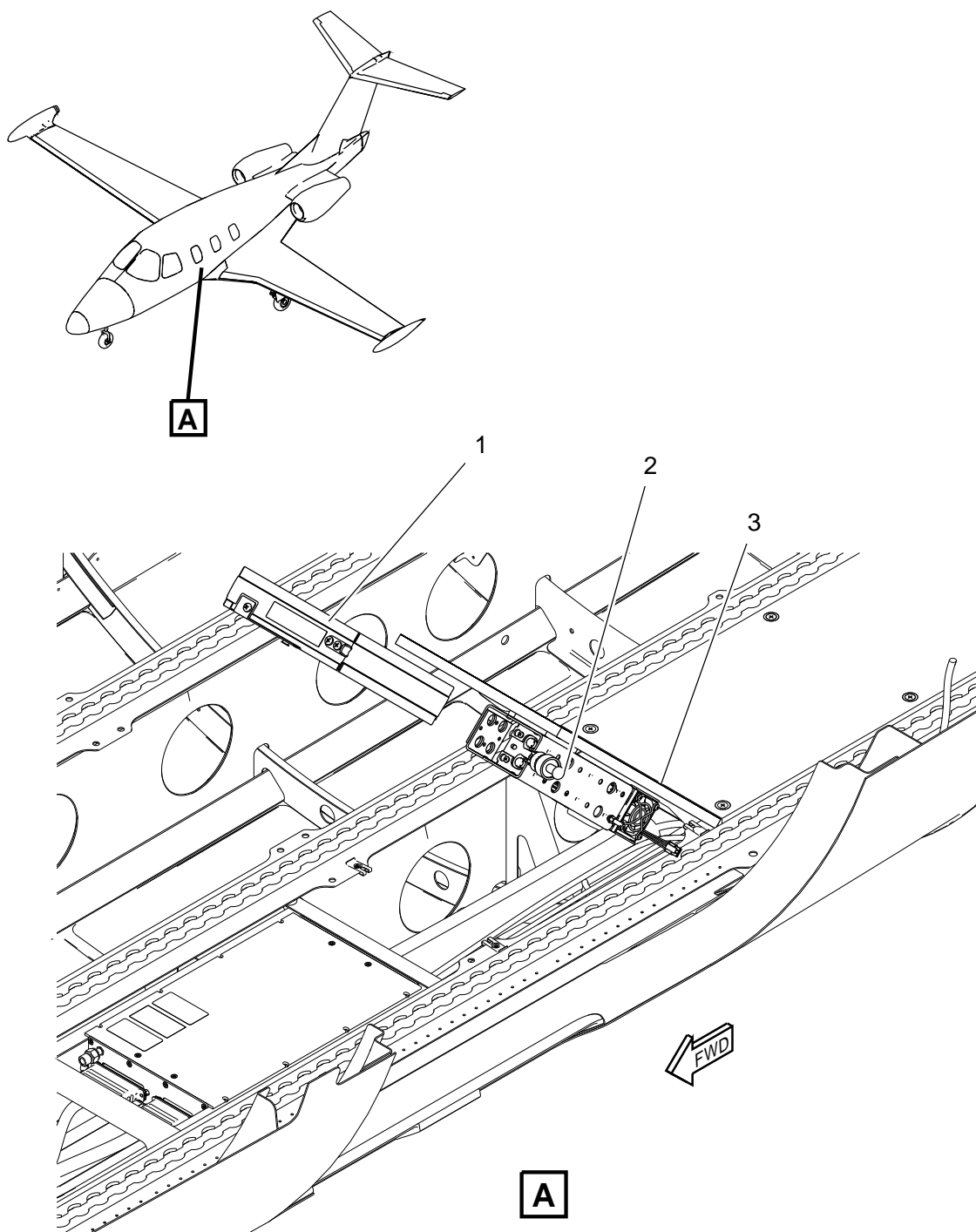

5181977A

**GPS 3 - Removal/Installation**  
**Figure 401 (Sheet 1 of 1)**

---

## **GPS - INSTALLATION**

AMM-34-50-11-041-801-D

### **1. General**

- A. This task gives the procedure to install the Global Positioning System/Wide Area Augmentation System (GPS/WAAS) sensors.
- B. There are two GPS/WAAS sensors installed in the aircraft. Installation steps are the same for the left and right sides, unless specified.

### **2. Job Set-Up**

SUBTASK AMM-34-50-11-041-D-921-001

- A. Make sure the aircraft is in the same configuration it was when the removal task was completed. Refer to [AMM-34-50-11-001-801 – GPS - Removal](#).

### **3. Procedure**

SUBTASK AMM-34-50-11-041-D-411-001

(Refer to [Fig. 401](#).)

- A. Put the GPS/WAAS sensor (4) on the mounting bracket (5) and align the bolt holes.
  - (1) Make sure the electrical connectors are facing forward.
  - (2) For the left side sensor, make sure the GPS/WAAS sensor (4) mounting flange is toward the outboard side of the aircraft and against the mounting bracket (5).
  - (3) For the right side sensor, make sure the GPS/WAAS sensor (4) mounting flange is toward the inboard side on the aircraft and away from the mounting bracket (5).
- B. Attach the GPS/WAAS sensor (4) to the mounting bracket (5).
  - (1) For the left side GPS/WAAS sensor (4), attach the sensor (4) to the mounting bracket (5) with the four bolts (1).
  - (2) For the right side GPS/WAAS sensor (4), attach the sensor (4) to the mounting bracket (5) with the four bolts (1) and spacers (6).
- C. Torque the bolts (1) to between 30-40 lbf.in (3.4-4.5 Nm).
- D. Bond the GPS/WAAS sensor (4) to the aircraft. Refer to [AMM-20-03-00-051-801 – Electrical Bonding - Maintenance Practices](#).
  - (1) Make sure the resistance is not more than 2.5 milliohms.
- E. Remove the protective caps from the electrical connector (2) and Coax Threaded Neil-Concelman (TNC) connector (3).
- F. Connect the electrical connector (2) and Coax TNC connector (3).
- G. Apply power to the aircraft. Refer to [AMM-24-40-00-051-801 – External Power - Maintenance Practices](#).

- H. Do an adjustment/test of the GPS system. Refer to [AMM-34-50-10-071-801 – GPS - Adjustment/Test](#).

**4. Job Close-Up**

SUBTASK AMM-34-50-11-041-D-921-002

- A. Remove all tools, equipment, and unwanted material from the work area.
- B. Install the 231 JZ – Cabin Headliner Assembly. Refer to [AMM-06-50-00-051-801 – Aircraft Access Panels](#).
- C. If all other maintenance is complete, return the aircraft to service. Refer to [AMM-20-00-02-051-801 – Return To Service \(After Maintenance\)](#).

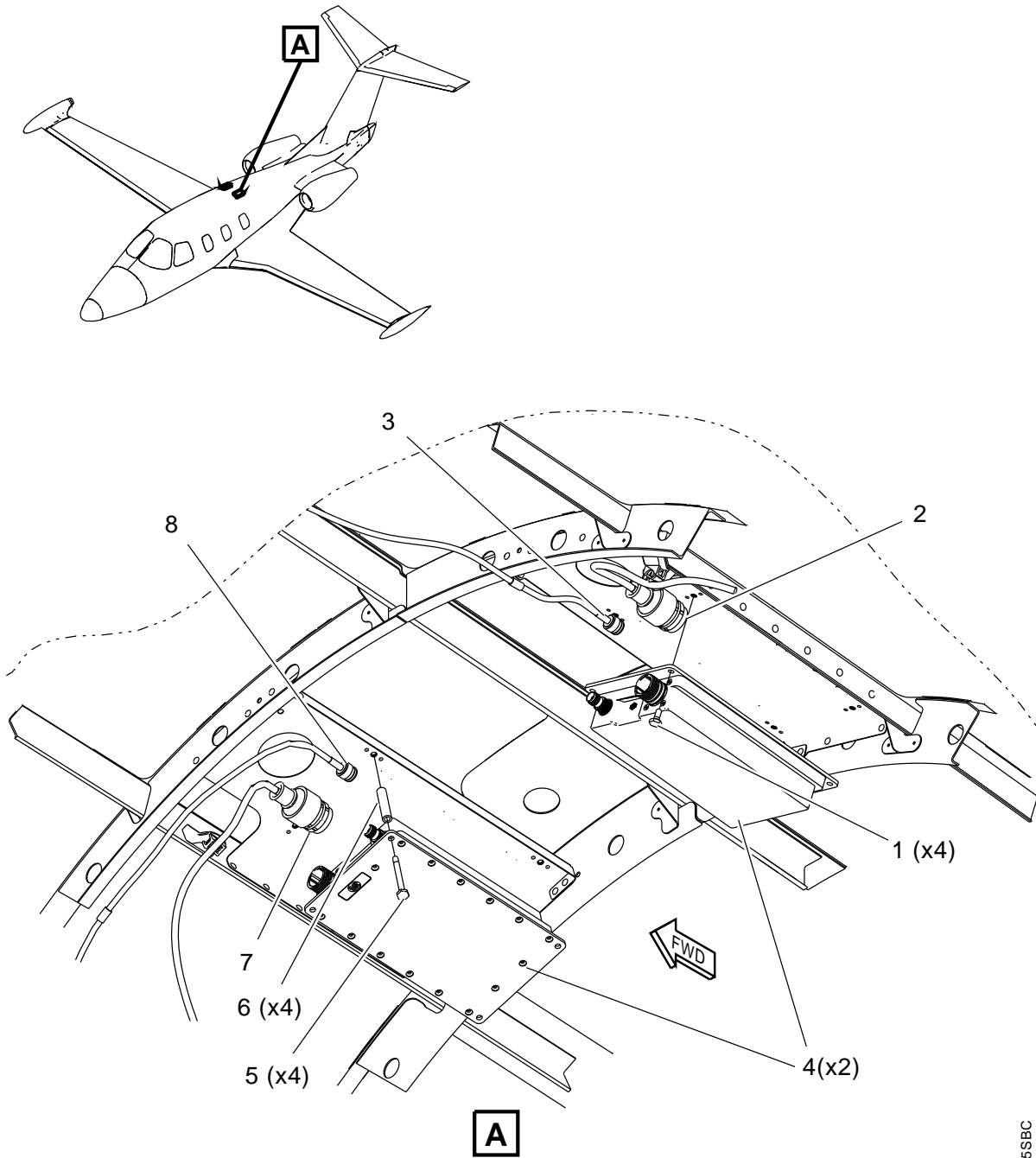

(ROTATED FOR CLARITY)

**GPS - Removal/Installation**  
**Figure 401 (Sheet 1 of 1)**

5A34051335SBC

THIS PAGE INTENTIONALLY LEFT BLANK

---

**GPS 3 MOUNT - REMOVAL**

AMM-34-50-13-001-801

**1. General**

- A. This task gives procedures to remove the Global Positioning System (GPS 3) mount.
- B. There is one GPS 3 mount installed under the baggage floor panel.

**2. Job Set-Up**

SUBTASK AMM-34-50-13-001-921-001

- A. Make aircraft safe for maintenance. Refer to [AMM-20-00-01-051-801 – Make Safe For Maintenance](#).
- B. Make sure all power is removed from the aircraft.
- C. Remove four screws, but do not remove 131 CZ-B - Floor Panel, Aft Short, Left Cabin. Refer to [AMM-25-11-30-001-801 – Cockpit Floor Panels - Removal](#).
- D. Remove the GPS 3 (GDL 88) unit. Refer to [AMM-34-50-11-001-C-801 – GPS 3-Removal](#).

**3. Procedure**

SUBTASK AMM-34-50-13-001-011-001

(Refer to [Fig. 401](#).)

**CAUTION:** DO NOT REMOVE 131 CZ-B - FLOOR PANEL, AFT SHORT, LEFT CABIN UNTIL MOUNT HAS BEEN DETACHED. THE GDL 88 MOUNT AND WIRING ARE ATTACHED TO THE UNDERSIDE OF THE FLOOR PANEL.

- A. Lift the forward edge and pivot 131 CZ-B - Floor Panel, Aft Short, Left Cabin (2) while supporting the GPS 3 mount (3), remove four screws (1).
- B. Remove 131 CZ-B - Floor Panel, Aft Short, Left Cabin (2).
- C. Disconnect wiring harness (4) from mount (3).
- D. Disconnect fan electrical molex connector (11) from harness molex connector (10).
- E. Disconnect 50 ohm/5 watt termination load (5) from the mount coax receptacle marked BTM

**NOTE:** The 50 ohm/5 watt termination load may remain connected with the mount if the same mount is to be reinstalled.

- F. Disconnect GPS antenna coax cable connector (6) from the mount GPS coax receptacle
- G. Remove nut (9) and disconnect jumper (8).
- H. Remove mount (3).

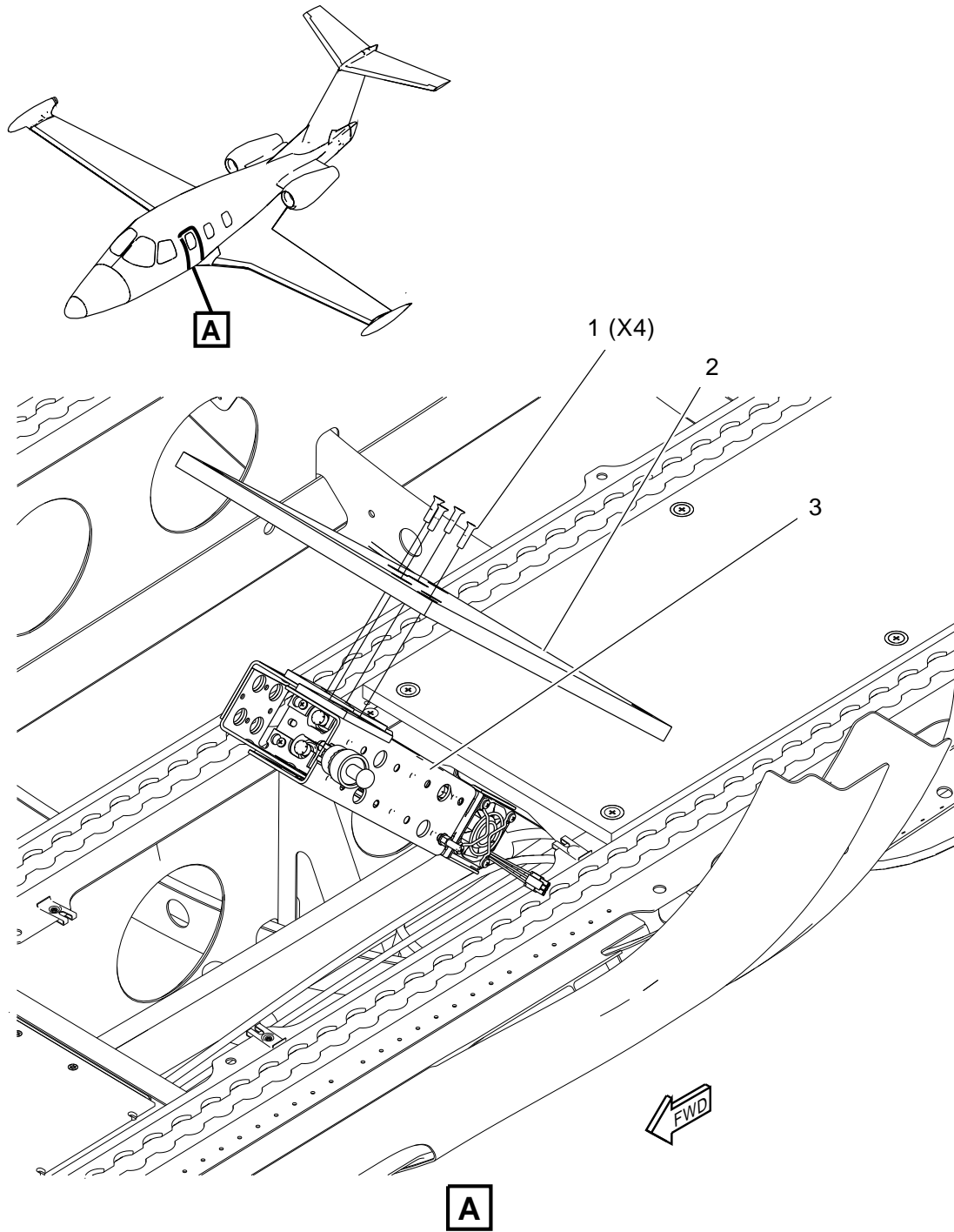

5181985A

**GPS 3 Mount - Removal/Installation**  
**Figure 401 (Sheet 1 of 2)**

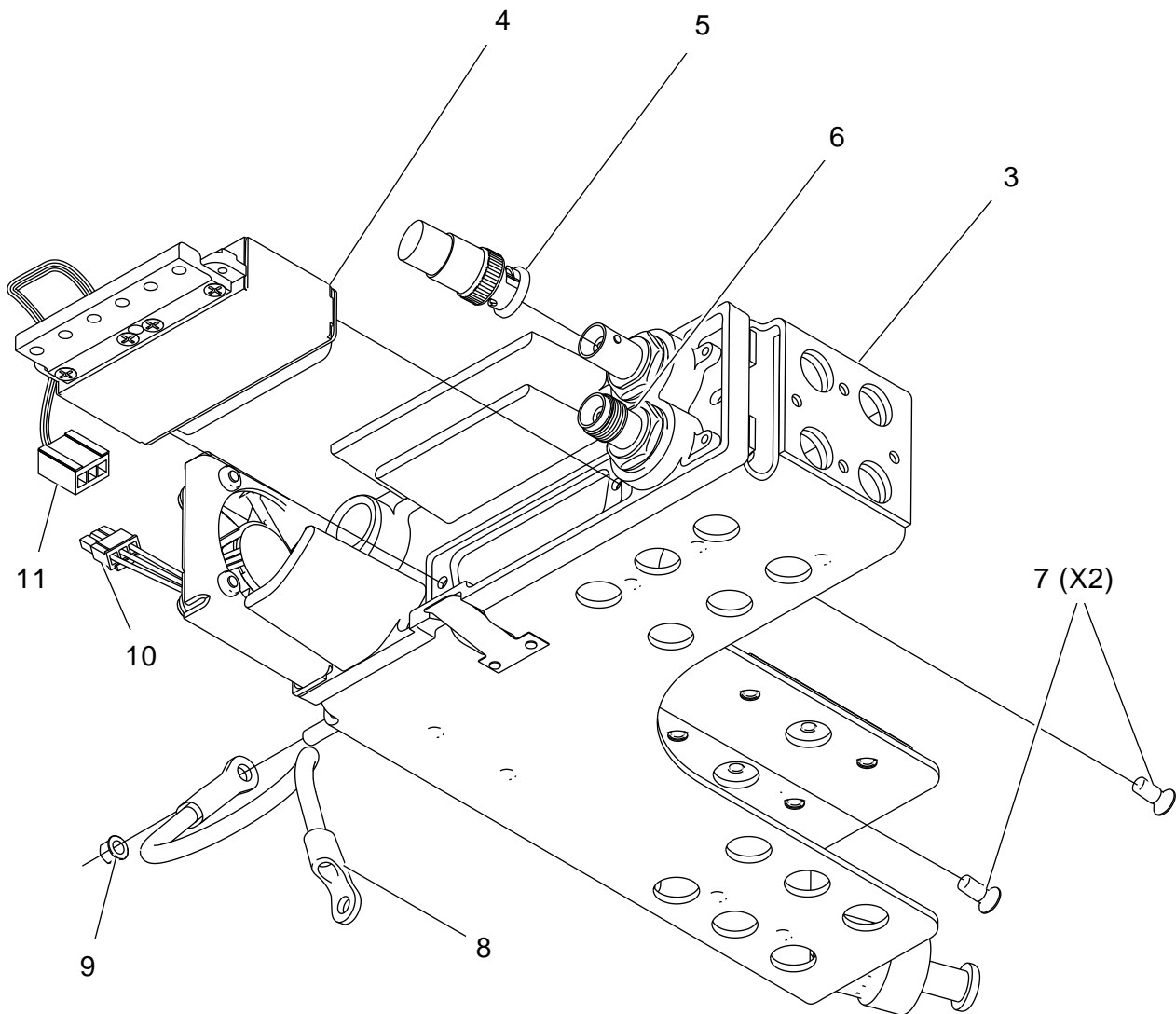

**GPS 3 Mount - Removal/Installation**  
**Figure 401 (Sheet 2 of 2)**

5181984A

THIS PAGE INTENTIONALLY LEFT BLANK

---

## **GPS 3 MOUNT - INSTALLATION**

AMM-34-50-13-041-801

### **1. General**

- A. This task gives the procedures to install the Global Positioning System (GPS 3) mount.
- B. There is one GPS 3 mount installed under the baggage floor panel.

### **2. Job Set-Up**

SUBTASK AMM-34-50-13-041-921-001

- A. Make sure the aircraft is in the same configuration as it was when the removal task was completed. Refer to [AMM-34-50-13-001-801 – GPS 3 Mount - Removal](#) .

### **3. Procedure**

SUBTASK AMM-34-50-13-041-411-001

(Refer to [Fig. 401.](#))

- A. Remove the protective caps from the electrical connectors.
- B. Connect jumper [\(8\)](#) to stud and install nut [\(9\)](#) .
- C. Connect wiring harness plug [\(4\)](#) to the mount [\(3\)](#) with two screws [\(7\)](#) . Torque screws [\(7\)](#) to 15-12 lbf.in (1.35-1.69 Nm).
- D. Connect fan electrical molex connector [\(10\)](#) to harness molex connector [\(11\)](#) .
- E. Connect the GPS antenna coax cable connector to the GPS coax receptacle [\(6\)](#) marked GPS.
- F. Connect 50 ohm/5 watt termination load [\(5\)](#) to coax receptacle marked BTM.
- G. Position mount on to 131 CZ-B - Floor Panel, Aft Short, Left Cabin [\(2\)](#) and align holes.
- H. Secure mount to 131 CZ-B - Floor Panel, Aft Short, Left Cabin [\(2\)](#) with four screws [\(1\)](#) . Torque screws to 15-12 lbf.in (1.35-1.69 Nm).

### **4. Job Close-Up**

SUBTASK AMM-34-50-13-041-921-002

- A. Install GPS 3 (GDL 88) unit. Refer to [AMM-34-50-11-041-C-801 – GPS 3 - Installation](#) .
- B. Install 131 CZ-B - Floor Panel, Aft Short, Left Cabin [\(2\)](#) .
- C. Remove all tools, equipment, and unwanted material from the work area.

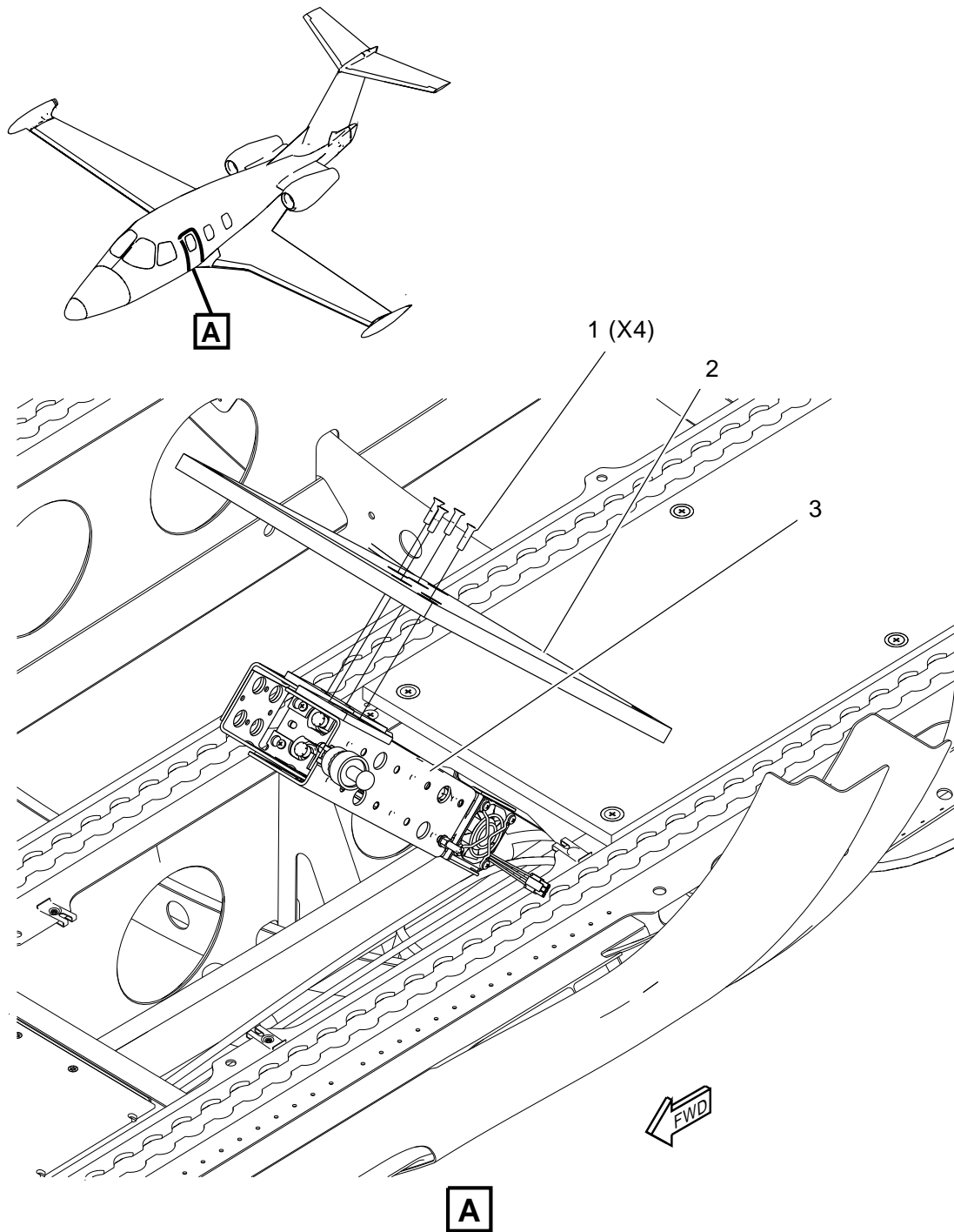

5181985A

**GPS 3 Mount - Removal/Installation**  
**Figure 401 (Sheet 1 of 2)**

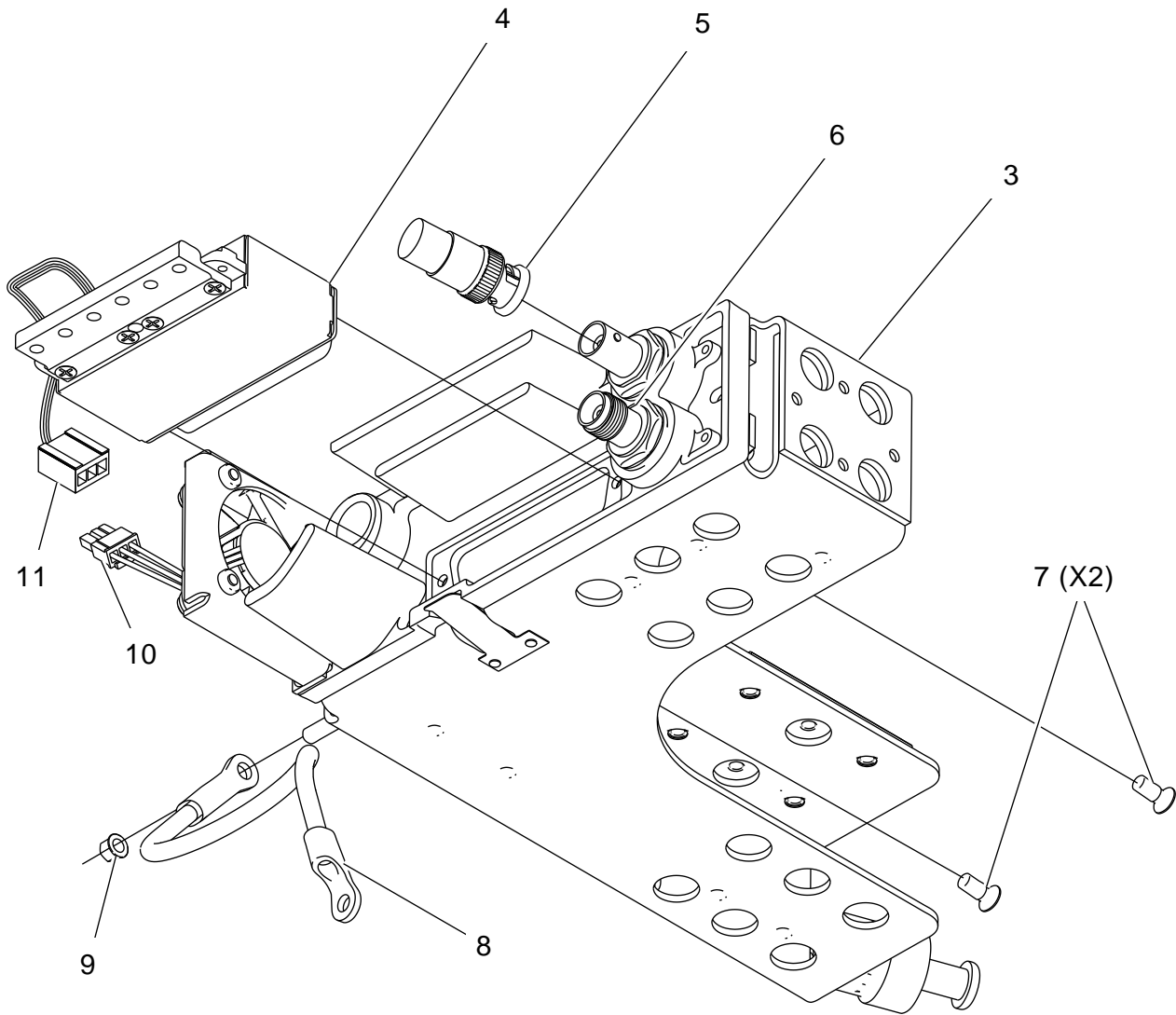

5181984A

**GPS 3 Mount - Removal/Installation**  
**Figure 401 (Sheet 2 of 2)**

THIS PAGE INTENTIONALLY LEFT BLANK

---

**GPS 2 ANTENNA SPLITTER - REMOVAL**

AMM-34-50-14-001-801

**1. General**

- A. This task gives procedures to remove the GPS 2 Antenna Splitter.
- B. There is one GPS 2 Antenna Splitter installed on the aircraft under 231 NZ - Floor Panel, Baggage Compartment.

**2. Job Set-Up**

SUBTASK AMM-34-50-14-001-921-001

- A. Make aircraft safe for maintenance. Refer to [AMM-20-00-01-051-801 – Make Safe For Maintenance](#).
- B. Make sure all power is removed from the aircraft.
- C. Remove 231 NZ - Floor Panel, Baggage Compartment. Refer to [AMM-06-50-00-051-801 – Aircraft Access Panels](#) for location and removal instructions.

**3. Procedure**

SUBTASK AMM-34-50-14-001-C-011-001

(Refer to [Fig. 401](#).)

- A. Disconnect the three coaxial connectors (3) from the GPS 2 Antenna Splitter (1).
  - (1) Install protective caps on the three coaxial connectors (3).
- B. Remove two screws (2) that attach the GPS 2 Antenna Splitter (1) to the aircraft.
- C. Remove the GPS 2 Antenna Splitter (1) from the aircraft.

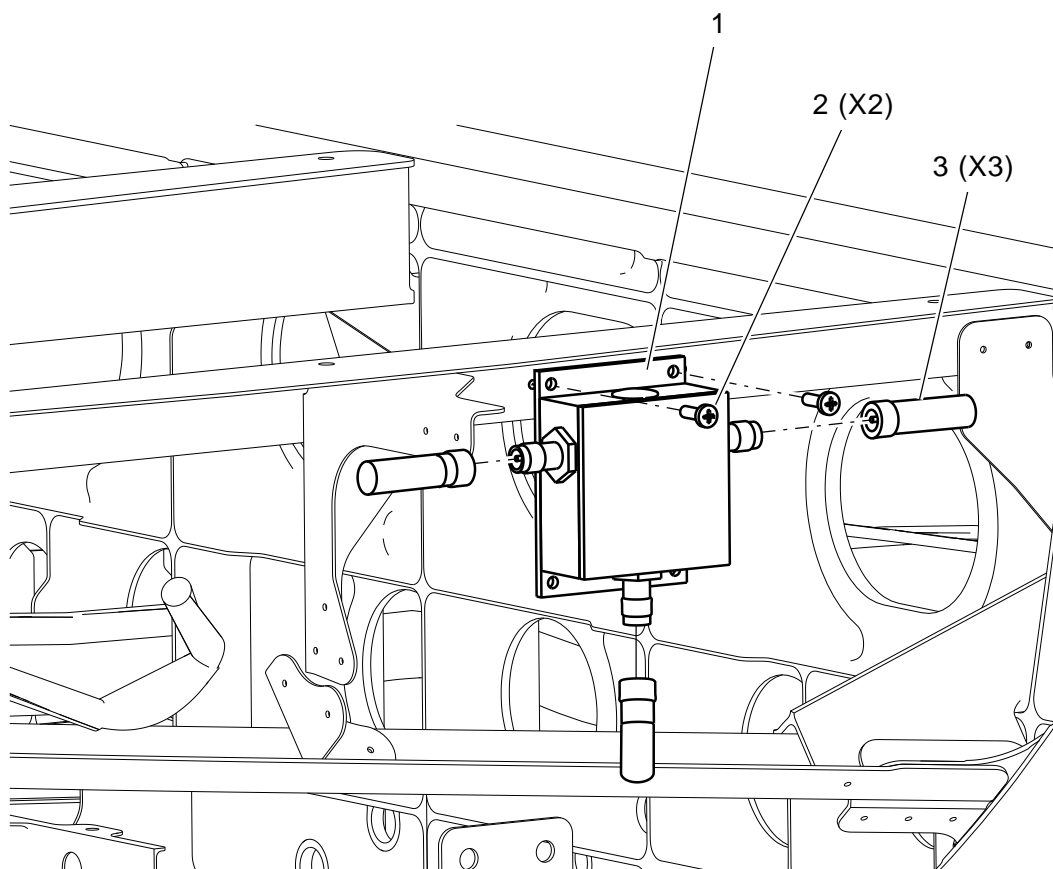
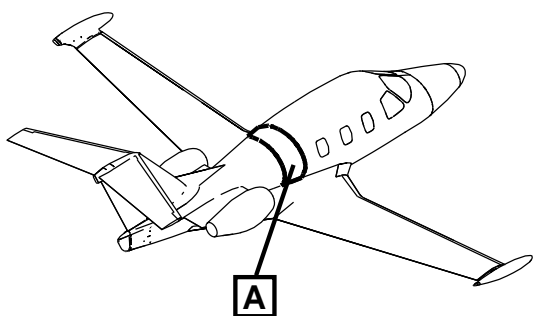

**A**

(SOME STRUCTURE REMOVED FOR CLARITY)

**GPS 2 Antenna Splitter - Removal/Installation**  
**Figure 401 (Sheet 1 of 1)**

5181963A

---

**GPS 2 ANTENNA SPLITTER - INSTALLATION**

AMM-34-50-14-041-801

**1. General**

- A. This task gives procedures to install the GPS 2 Antenna Splitter.
- B. There is one GPS 2 Antenna Splitter installed on the aircraft under 231 NZ - Floor Panel, Baggage Compartment.

**2. Job Set-Up**

SUBTASK AMM-34-50-14-041-921-001

- A. Make sure the aircraft is in the same configuration as it was when the removal task was completed. Refer to [AMM-34-50-14-001-801 – GPS 2 Antenna Splitter - Removal](#)

**3. Procedure**

SUBTASK AMM-34-50-14-041-411-001

(Refer to [Fig. 401.](#))

- A. Remove the protective caps from the three coaxial connectors [\(3\)](#) .
- B. Put the GPS 2 Antenna Splitter [\(1\)](#) on the structure and align the screw holes.
- C. Attach the GPS 2 Antenna Splitter [\(1\)](#) to the aircraft with two screws [\(2\)](#) . Torque the screws [\(2\)](#) to 30-40 lbf.in (3.4-4.5 Nm).
- D. Connect the three coaxial connectors [\(3\)](#) on the splitter [\(1\)](#) .
- E. Electrically bond the GPS 2 Antenna Splitter to the structure. Refer to [AMM-20-03-00-051-801 – Electrical Bonding - Maintenance Practices](#). Resistance must be 2.5 milliohms or less.

**4. Job Close-Up**

SUBTASK AMM-34-50-14-041-921-002

- A. Install 231 NZ - Floor Panel, Baggage Compartment. Refer to AMM-06-50-00-051-801 – Aircraft Access Panels for location and installation instructions.
- B. Remove all tools, equipment, and unwanted material from the work area.
- C. Do GPS 2 Adjustment/Test. Refer to [SUBTASK AMM-34-50-10-071-C-801-003](#).
- D. Do a system test of the ADS-B. Refer to [SUBTASK AMM-34-50-20-071-C-701-005](#).
- E. If all other maintenance is complete, return the aircraft to service. Refer to [AMM-20-00-02-051-801 – Return To Service \(After Maintenance\)](#).

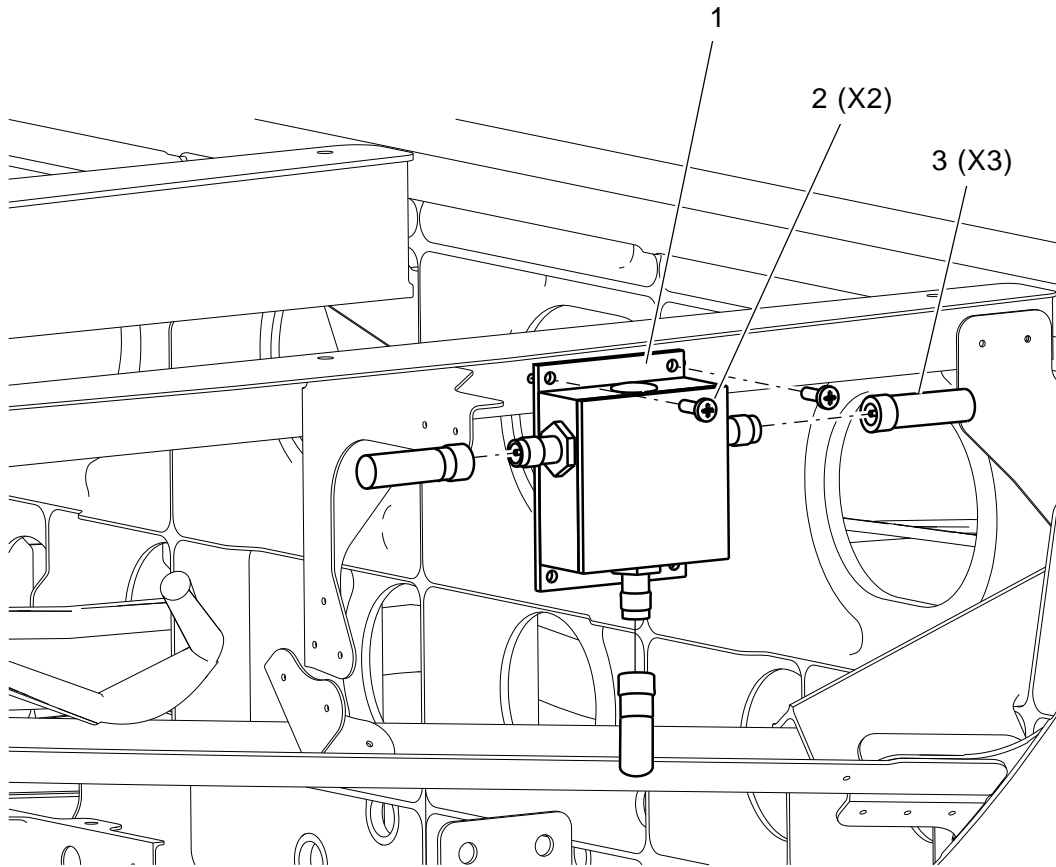
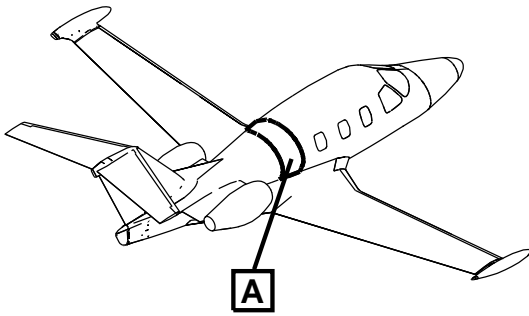

**A**

(SOME STRUCTURE REMOVED FOR CLARITY)

**GPS 2 Antenna Splitter - Removal/Installation**  
**Figure 401 (Sheet 1 of 1)**

5181963A

---

## **TRANSPONDER - DESCRIPTION AND OPERATION**

AMM-34-50-20-081-C-801

### **1. Introduction**

- A. Standard Transponder System with or without Extended Squitter: |
- (1) The standard transponder system provides aircraft identification (Mode S), and altitude (Mode C) information to Air Traffic Control.
  - (2) The standard transponder system is made up of the components that follow:
    - Dual standard transponder units installed behind the Primary Flight Displays (PFD)
    - Two transponder antennas
- B. Optional Diversity Transponder System with or without Extended Squitter:: |
- (1) The diversity transponder system provides aircraft identification (Mode S) and altitude reporting information (Mode C) to Air Traffic Control.
  - (2) The diversity transponder system is made up of the components that follow:
    - Dual diversity transponder units installed behind the Primary Flight Displays (PFD)
    - Two transponder antennas
    - Two RF antenna switching relays

### **2. Description**

SUBTASK AMM-34-50-20-081-C-871-001

- A. Standard Transponder System:
- (1) There are two transponders, one (transponder number 1) is installed in the instrument panel behind the left PFD and the other (transponder number 2) is installed in the instrument panel behind the right PFD.
- B. Optional Diversity Transponder System:
- (1) There are two diversity transponders, one (diversity transponder number 1) is installed in the instrument panel behind the left PFD and the other (diversity transponder number 2) is installed in the instrument panel behind the right PFD.
  - (2) There are two RF antenna switching relays, both installed behind the Multi Function Display (MFD). One is inboard of the left diversity transponder and the other is inboard of the right diversity transponder. |

### 3. Operation

#### SUBTASK AMM-34-50-20-081-C-871-002

##### A. Standard Transponder System:

The two transponder units located behind the left and right PFDs provide identification information (Modes A and S) and altitude reporting information (Mode C).

The rack mounted dual Mode S transponder system are a radio transmitter-receivers that operate on radar frequencies, receiving ground radar and Traffic Collision Avoidance System interrogations at 1030 MHz and transmitting a coded response of pulses on a frequency of 1090 MHz. The transponder is equipped with the IDENT capability that activates the Special Position Identification pulse for 18 seconds. IDENT function is available through the designated button on the respective side grip.

The GTX 33 replies to Mode A, Mode C, and Mode S interrogations. Mode A replies consist of framing pulses and any one of 4,096 codes (also known as "squawk codes"), which differ in the position and number of pulses transmitted. Mode C replies include framing pulses and encoded altitude.

There are two transponder antennas. The number 1 upper transponder antenna is mounted on the top of the fuselage and is connect to transponder number 1 behind the left PFD. The number 2 lower transponder antenna is mounted on the bottom of the fuselage and is connect to transponder number 2 behind the right PFD.

##### B. Optional Diversity Transponder System:

As an option, the transponders allow for antenna diversity feature available through the connection of both antennas to a single transponder unit. this is realized by the RF antenna switching relay and the diversity configuration control bit to the PFD available for configuration though the Aircraft Maintenance Computer (AMC). An active transponder alternates between the upper and lower antennas ensures the quality and reliability of the transponder system communications.

---

## **TRANSPONDER - DESCRIPTION AND OPERATION**

AMM-34-50-20-081-D-801

### **1. Introduction**

#### **A. Standard Transponder System:**

- (1) The standard transponder system provides aircraft identification (Mode S), altitude (Mode C), and Automatic Dependent Surveillance Broadcast (ADS-B) OUT information to Air Traffic Control.
- (2) The standard transponder system is made up of the components that follow:
  - Dual standard transponder units with Extended Squitter installed behind the Primary Flight Displays (PFD)
  - Two transponder antennas

#### **B. Optional Diversity Transponder System:**

- (1) The diversity transponder system provides aircraft identification (Mode S) and altitude reporting information (Mode C) to Air Traffic Control.
- (2) The diversity transponder system is made up of the components that follow:
  - Dual diversity transponder units installed behind the PFDs.
  - Two transponder antennas
  - Two RF antenna switching relays

#### **C. ADS-B Function**

The Extended Squitter enabled transponders provide the capabilities of ADS-B technology, which improves situational awareness and flight safety. The ADS-B OUT function is an option and may be activated through the Multi Function Display (MFD) software key pertinent to a specific aircraft registration number.

### **2. Description**

SUBTASK AMM-34-50-20-081-D-871-001

#### **A. Standard Transponder System:**

- (1) There are two transponders, one (transponder number 1) is installed in the instrument panel behind the left PFD and the other (transponder number 2) is installed in the instrument panel behind the right PFD.

#### **B. Optional Diversity Transponder System:**

- (1) There are two diversity transponders, one (diversity transponder number 1) is installed in the instrument panel behind the left PFD and the other (diversity transponder number 2) is installed in the instrument panel behind the right PFD.
- (2) There are two RF antenna switching relays, both installed behind the MFD. One is inboard of the left diversity transponder and the other is inboard of the right diversity transponder.

### C. ADS-B Function

The Extended Squitter enabled transponders provide the capabilities of ADS-B technology, which improves situational awareness and flight safety. The ADS-B OUT function is an option and may be activated through the MFD software key pertinent to a specific aircraft registration number.

## 3. Operation

### SUBTASK AMM-34-50-20-081-D-871-002

#### A. Standard Transponder System:

The two transponder units located behind the left and right PFDs provide identification information (Modes A and S) and altitude reporting information (Mode C).

The rack mounted dual Mode S transponder system are a radio transmitter-receivers that operate on radar frequencies, receiving ground radar and Traffic Collision Avoidance System interrogations at 1030 MHz and transmitting a coded response of pulses on a frequency of 1090 MHz. The transponder is equipped with the IDENT capability that activates the Special Position Identification pulse for 18 seconds. IDENT function is available through the designated button on the respective side grip.

The GTX 33 replies to Mode A, Mode C, and Mode S interrogations. Mode A replies consist of framing pulses and any one of 4,096 codes (also known as "squawk codes"), which differ in the position and number of pulses transmitted. Mode C replies include framing pulses and encoded altitude.

There are two transponder antennas. The number 1 upper transponder antenna is mounted on the top of the fuselage and is connect to transponder number 1 behind the left PFD. The number 2 lower transponder antenna is mounted on the bottom of the fuselage and is connect to transponder number 2 behind the right PFD.

#### B. Optional Diversity Transponder System:

As an option, the transponders allow for antenna diversity feature available through the connection of both antennas to a single transponder unit. this is realized by the RF antenna switching relay and the diversity configuration control bit to the PFD available for configuration though the Aircraft Maintenance Computer (AMC). An active transponder alternates between the upper and lower antennas ensure the quality and reliability of the transponder system communications.

#### C. ADS-B Function

The Extended Squitter enabled transponders provides the capabilities of ADS-B technology, which improves situational awareness and flight safety. With ADS-B capabilities, position, velocity, and heading information are automatically transmitted to other aircraft and ground stations. The current Air Traffic Control system depends on a transponder request for pertinent aircraft information. ADS-B provides immediate surveillance of air-to-air traffic and aircraft in remote or inhospitable areas not currently covered by radar.

## TRANSPONDER WITH ADS-B OUT – MAINTENANCE PRACTICES

AMM-34-50-20-051-801

### 1. General

- A. The purpose of this task is to provide instructions for configuring the Transponder for ADS-B Out on the Eclipse 500 aircraft.  
The following procedure is to be performed on the bench.
- B. If the aircraft has ADS-B OUT function, ensure this transponder has Extended Capability (ES) enabled and software version is at 8.02 or above.

NOTE: If necessary, update transponder software to the required level.

### 2. Equipment and Materials

**Table 201. Special Tools and Equipment**

Name and Part Number
Portable Power Supply capable of outputting 28 ± 0.5 VDC
Harness Assy, GTX-33 Test (87-124598-1001)
PC with Windows Hyper Terminal with RS-232 Serial Port or USB to Serial Adapter (available with Windows XP OS only)

### 3. Job Set-Up

SUBTASK AMM-34-50-20-051-921-001

- A. Make aircraft safe for maintenance. Refer to [AMM-20-00-01-051-801 – Make Safe For Maintenance](#).
- B. If installed on aircraft, remove affected transponder from aircraft. Refer to [AMM-34-50-21-001-801 – Transponder - Removal](#).
- C. Obtain the transponder configuration files from Eclipse Service Engineering. One of the configuration files sets transponder configuration to factory defaults; another file enables the ADS-B OUT function and configures the associated parameters to the required values.
- D. Turn the power supply on and make sure the power supply is set to 28 ± 0.5 VDC. Turn the power supply off.
- E. Connect transponder, PC and Power supply with Harness Assy, GTX-33 Test (87-124598-1001). Refer to [Fig. 201, Sheet 1](#).  
Make sure the Test Switch on the cable is in the OFF position.

NOTE: Make sure that 50 ohm/5 watt terminators are installed on transponder antenna ports P02 and P03.

- F. Set up Hyper Terminal Interface as follows:

- (1) On the PC with Windows XP OS only, open Windows Hyper Terminal app (All Programs>Accessories>Communications>Hyper Terminal) and enter *xpdr\_configuration* as name for the connection. Refer to [Fig. 202, Sheet 1](#).
- (2) Enter the following connection properties: Refer to [Fig. 202, Sheet 2](#).
  - Connect To – Connect using: COM1
  - COM1 Properties:
    - Bits per second: 9600
    - Data bits: 8
    - Parity: None
    - Stop bits: 1
    - Flow control: None
- (3) To connect to the device, press **call** button; to disconnect, press **disconnect** button. Figure [Fig. 202, Sheet 3](#) shows the communication with the transponder when connected.
- (4) To send a file to the connected device, select the file through the Transfer-> Send Text File. Refer to [Fig. 202, Sheet 4](#).

#### 4. Procedure

SUBTASK AMM-34-50-20-051-701-002

A. Perform the following configuration procedure.

- (1) Make sure the Test Switch on the cable is in the OFF position.
- (2) Turn the power supply on and power up the transponder.
- (3) Ensure the connection with transponder can be established by pressing the call button on the Hyper Terminal interface.
- (4) Once the transponder is communicating with the computer, send the configuration file to the transponder to reset transponder configuration to factory defaults.
- (5) Stop transponder communication using the disconnect button on the Hyper Terminal interface.
- (6) Cycle power to the transponder.
- (7) Ensure the connection with transponder can be established by pressing the call button on the Hyper Terminal interface.
- (8) Once the transponder is communicating with the computer, send the ADS-B OUT parameter configuration file.
- (9) Stop transponder communication using the disconnect button on the Hyper Terminal interface.
- (10) Power down the transponder.

**5. Job Close-Up**

SUBTASK AMM-34-50-20-051-921-002

- A. Disconnect Harness Assy, GTX-33 Test (87-124598-1001) from Power Supply and Transponder.

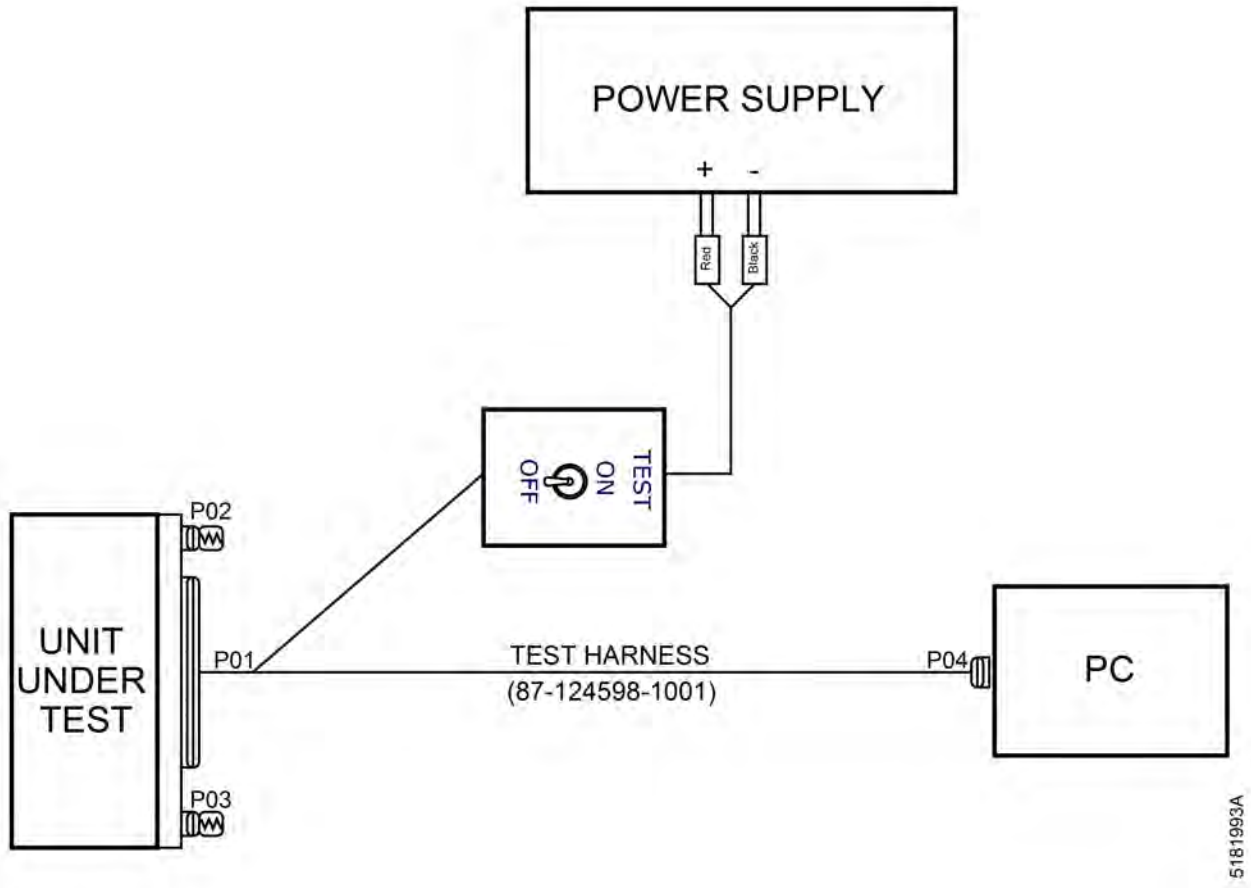

**Test Setup**  
**Figure 201 (Sheet 1 of 1)**

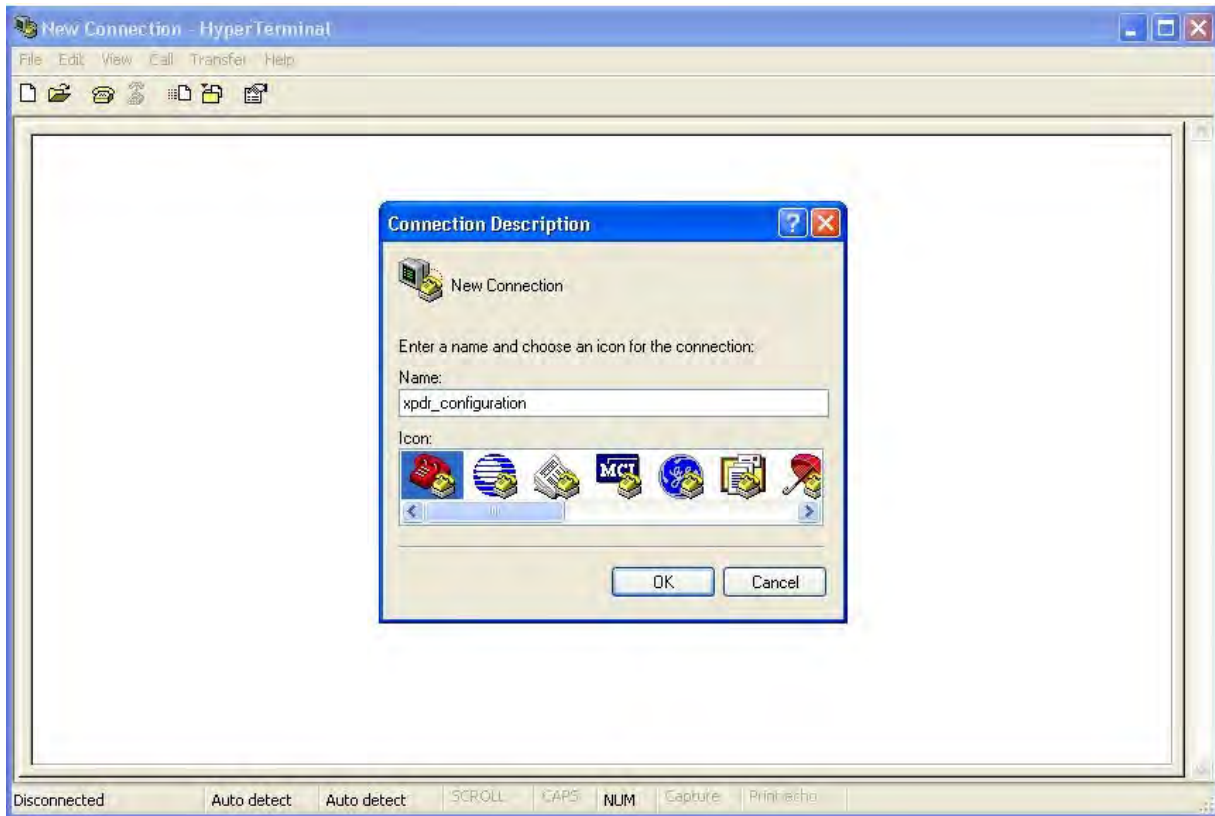

**Hyper Terminal – New Connection  
Figure 202 (Sheet 1 of 4)**

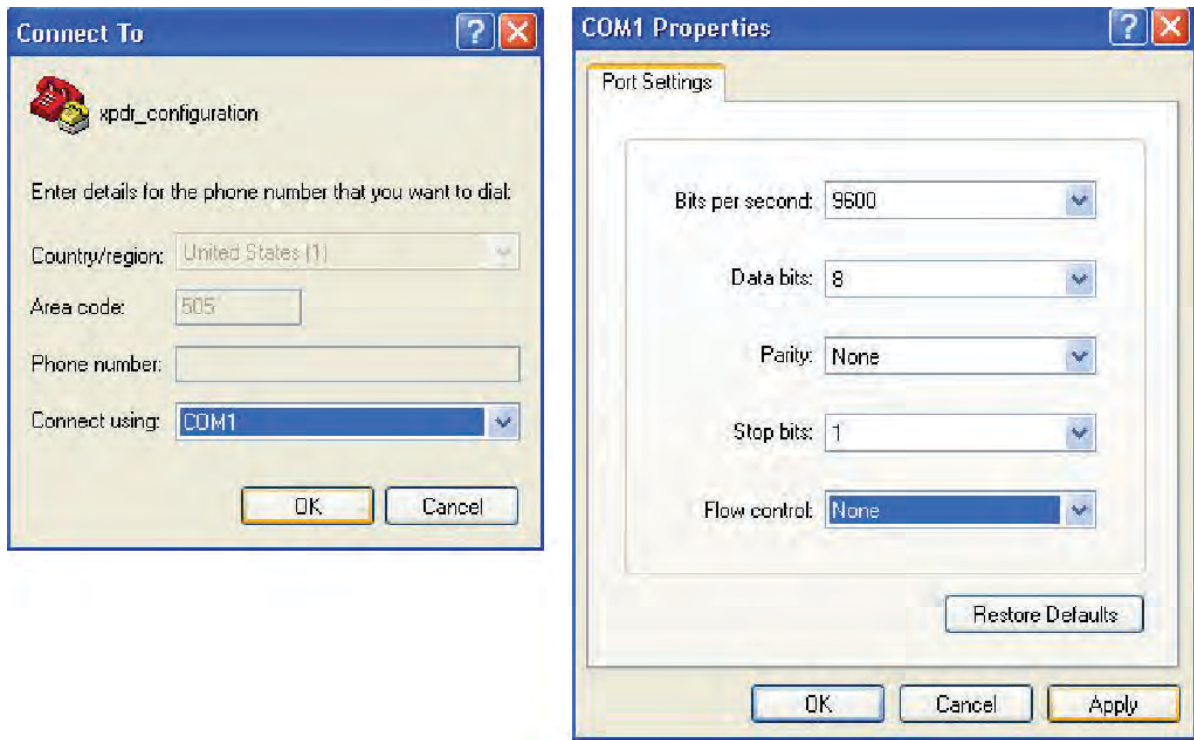

5181995A

**Hyper Terminal – Connection Properties**  
**Figure 202 (Sheet 2 of 4)**

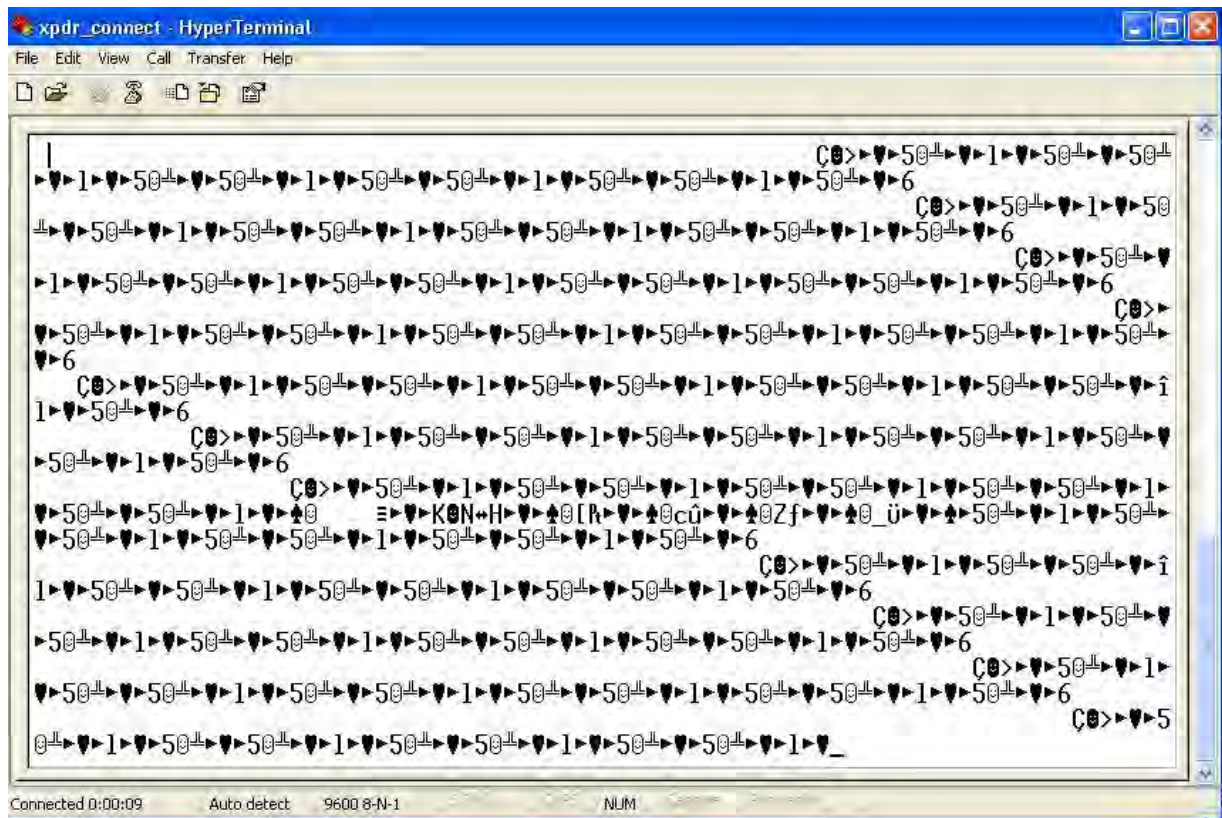

**Hyper Terminal – Comm Demo**  
**Figure 202 (Sheet 3 of 4)**



5181997A

**Hyper Terminal – Send File**  
**Figure 202 (Sheet 4 of 4)**

## TRANSPONDER - ADJUSTMENT/TEST

AMM-34-50-20-071-A-801

### 1. General

- A. This task gives procedures to do the adjustment/test of the transponder components.
- An adjustment/test is only required for the transponder that is being installed. The opposite transponder, if it has not been removed, does not require an adjustment/test
  - There are two testing methods, the preferred method is with the use of a transponder antenna coupler to limit emissions that may interfere with Air Traffic Control operations and the second method which uses the IFR-6000 antennas.

### 2. Equipment and Materials

**Table 501. Special Tools and Equipment**

Name and Part Number
Transponder Test Set (Aeroflex, IFR6000)
UC-584 Universal Transponder Antenna Coupler   Dual Antenna Kit (Viavi 112349)[1]
Weight-on-Wheels (WOW) Box (EAI, 87-117390-1001) or Avio Maintenance Computer (AMC) (EAI 20-120576-1001 or 20-121926-1001), SW version "1.5.71 or higher" for Pre-Avio NG aircraft and "2.2.02 or higher" for Avio NG aircraft
PCMCIA to Parallel Port Adapter, (Quatech, PN SPP-100), for use with Transponder Programming Kit, (Bender, PN AMP6400-1 (parallel port) or PN AMP6400-2 (USB)).
Transponder Programming Kit, (Bender, PN AMP6400-1 (parallel port) or PN AMP6400-2 (USB))
Personal Computer (PC) — for Address Module Programming

[1] For test with UC-584 antenna coupler.

### 3. Job Set-Up with UC-584 Antenna Couplers

SUBTASK AMM-34-50-20-071-921-001-A

Refer to [Fig. 501](#).

- A. Make aircraft safe for maintenance. Refer to [AMM-20-00-01-051-801 – Make Safe For Maintenance](#).
- B. If on jacks, refer to [AMM-07-10-00-051-801 – Jacking - Maintenance Practices](#) and [AMM-08-20-00-051-801 – Leveling](#).
- C. Connect external power. Refer to [AMM-24-40-00-051-801 – External Power - Maintenance Practices](#). Do not turn on START BATT and SYS BATT switches until prompted.
- D. Prepare Anti-ice system for maintenance. Refer to [AMM-20-00-03-051-801 – Prepare Anti-Ice Systems For Maintenance](#).
- E. Connect Antenna Coupler UC-584S to Aircraft upper Transponder Antenna as follows: (as applicable)

NOTE: For Transponder–1 Adjustment/Test

- (1) Place Antenna Coupler (2) over the antenna (3), guiding antenna in to the slot on the bottom of the coupler.
- (2) Lock Antenna Coupler (2) into place by pushing lever on the side of the coupler into a down and locked position.

NOTE: Coupler must be tightly pressed and locked in place for Test Set to function correctly. Coupler will lock into place when the black rubber gasket is not completely depressed against the aircraft, but the Test Set will not measure functions accurately.

CAUTION: DO NOT CONNECT COAX CABLE TO IFR-6000 ANT PORT. DAMAGE TO EQUIPMENT WILL OCCUR.

- (3) Connect long RF coaxial cable (1) between the Antenna Coupler (2) and Test Set RF I/O Connector.

CAUTION: THE RF COAXIAL CABLE CAN BE A TRIPPING HAZARD. MAKE SURE TO SECURE THE CABLE. PERSONAL INJURY AND DAMAGE TO THE ANTENNAS AND TEST EQUIPMENT COULD OCCUR.

- (4) Temporarily secure the coaxial cable to the aircraft with tape. Tape can be removed after the test is completed.
- (5) Push Antenna Coupler (2) firmly against the aircraft skin until the black rubber gasket on the rim of the coupler is completely depressed tightly against the aircraft.

- F. Connect Antenna Coupler UC-584 to Aircraft lower Transponder Antenna as follows: (as applicable)

NOTE: For Transponder–2 Adjustment/Test

- 
- (1) Place Antenna Coupler (2) over the antenna (4) , guiding antenna in to the slot on the bottom of the coupler.
  - (2) Lock Antenna Coupler (2) into place by pushing lever on the side of the coupler into a down and locked position.  

**NOTE:** Antenna Coupler must be tightly pressed and locked in place for Test Set to function correctly. Coupler will lock into place when the black rubber gasket is not completely depressed against the aircraft, but the Test Set will not measure functions accurately.
  - CAUTION:** DO NOT CONNECT COAX CABLE TO IFR-6000 ANT PORT. DAMAGE TO EQUIPMENT WILL OCCUR.
  - (3) Connect long RF coaxial cable (1) between the Antenna Coupler and Test Set RF I/O Connector.  

**CAUTION:** THE RF COAXIAL CABLE CAN BE A TRIPPING HAZARD. MAKE SURE TO SECURE THE CABLE. PERSONAL INJURY AND DAMAGE TO THE ANTENNAS AND TEST EQUIPMENT COULD OCCUR.
  - (4) Temporarily secure the coaxial cable to the aircraft with tape. Tape can be removed after the test is completed.
  - (5) Push Antenna Coupler (2) firmly against the aircraft skin until the black rubber gasket on the rim of the coupler is completely depressed tightly against the aircraft.
- G. Connect Weight On Wheels (WOW) box or Aircraft Maintenance Computer (AMC) and set switches on Box to W-On-W (on-ground). Refer to [AMM-20-00-04-051-801 – Weight On Wheels \(WOW\) Box - Connect/Disconnect](#).

#### 4. Procedure with UC-584 Antenna Couplers

SUBTASK AMM-34-50-20-071-A-701-001

A. Do adjustment/test of the Transponder System as follows:

- (1) Perform job setup, refer to [SUBTASK AMM-34-50-20-071-A-921-001-B](#).
- (2) Push ECB BY SYSTEM soft key. Scroll to FLT CTRLS using outer knob. Push inner knob to select. Scroll to the listed ECB using outer knob and highlight. Push “COLLAR” Soft key. Press “CONFIRM COLLAR” soft key.
  - ECB - NOSE LDG GEAR (L AFT Bus)
  - ECB - L MAIN LDG GEAR (L AFT Bus)
  - ECB - R MAIN LDG GEAR (L AFT Bus)
- (3) Set WOW Box to W-off-W.

NOTE: Transponders only turn on with Weight-off-Wheels.

- (4) Set both left and right PFD baro set to 29.92 on Autopilot Control Panel (ACP) by pressing BARO SET knob.

B. Transponder-1 Setup using Transponder Test Set, IFR6000

- (1) Press the bottom right rocker switch on the left PFD to select XPDR.

NOTE: The XPDR select page times out and switches back to the COM page after 30 seconds. Select XPDR page from time to time during this test.
- (2) Press ACTIVE softkey (upper right button) on the left PFD to select XPDR1.
- (3) CODE status box on the left PFD and right PFD shows 1200.
  - (a) To change CODE, scroll to XPDR using softkey. Use outer knob to highlight and inner knob to change numeric values.

- (4) Press MODE softkey on the left PFD to select ON.
- (5) Press the bottom right rocker switch on the right PFD to select XPDR.

NOTE: The XPDR select page times out and switches back to the COM page after 30 seconds. Select XPDR page from time to time during this test.

- (6) Press ACTIVE softkey (upper right button) on the right PFD to select XPDR1.
- (7) Set CODE to 1300, scroll to XPDR using softkey, and use the outer knob to highlight and inner knob to change numeric values.
- (8) CODE status box on the Left PFD and Right PFD shows 1300.

NOTE: Upon completion of Right PFD test, return CODE to 1200.

- (9) Press MODE softkey on the right PFD to select ON.
- (10) Using the pilot’s keyboard, perform the following steps:
  - (a) Press XPDR1.
    - Keyboard XPDR1 LED is lit.
  - (b) Press ON.

- 
- (c) Press XPDR SQWK.
  - (d) Using the keyboard numbers, set the code to 1200.
  - (e) Press Enter.
    - CODE status box on the left PFD shows 1200.
- C. Transponder-1 MODE A,C,S Test using Transponder Test Set, IFR6000
- (1) Power Up: Press the POWER Key to power the Test Set.
  - (2) Press SETUP Control Key to display setup screens. Continue pressing SETUP Control Key to cycle to SETUPXPDR Screen. Use NEXT PARAM and PREV PARAM Soft Keys to select each parameter.
  - (3) Select RF PORT: Select DIR W/COUPLER
    - (a) Select CPL CABLE LOSS: Set to loss found on cable.
    - (b) Select COUPLER LOSS: Set to loss found on coupler.
  - (4) Press XPDR button to go to the XPDR AUTO TEST page.
  - (5) Press CONFIG button. On the CONFIG line, scroll to GENERIC MODE S using the up/down buttons. Press Return button and select Run Test, found on display screen.
    - Top ERP dBm should be between 48 to 60 and MTL. dBm should be between -67 to -79 to PASS.
  - (6) Press STOP TEST button.
  - (7) Repeat until all FAILED tests have been completed.
  - (8) Press Return button on IFR 6000 to return to XPDR-AUTO. TEST screen appears.
    - A PASS message should be displayed.
  - (9) On left PFD, scroll to XPDR using lower softkey.
  - (10) Press MODE softkey to change the mode to ALT.
  - (11) CODE status box on the left PFD and right PFD show 1200.
  - (12) Press RUN TEST button on Transponder Test Set, IFR6000.  
Transponder Test Set, IFR6000 indicates:
    - A Code = 1200
    - C Alt = Reading within +/- 100 ft. of the Left PFD altitude reading
  - (13) On Transponder Test Set, IFR6000, press XPDR button one time. Check that the following is displayed:
    - XPDR – ALT ENCODER
  - (14) On Transponder Test Set, IFR6000, press Source Select button. Check that the following is displayed:
    - SOURCE: XPDR
  - (15) On Transponder Test Set, IFR6000, select RUN TEST.
- NOTE:** Wait approximately 30 Seconds between cockpit IDENT tests.

- (16) Press IDNT key on the Pilot's keyboard.
    - IDENT is displayed on Transponder Test Set, IFR6000.

NOTE: IDENT disappears from the IFR test set in approximately 20 seconds.
  - (17) Press IDNT key on the Copilot's keyboard (If Installed).
    - IDENT is displayed on Transponder Test Set, IFR6000.

NOTE: IDENT disappears from the IFR test set in approximately 20 seconds.
  - (18) Press IDNT button on the Pilot's Stick Grip.
    - IDENT is displayed on Transponder Test Set, IFR6000.

NOTE: IDENT disappears from the IFR test set in approximately 20 seconds.
  - (19) Press IDENT button on the Copilot's Stick Grip.
    - IDENT is displayed on Transponder Test Set, IFR6000.

NOTE: IDENT disappears from the IFR test set in approximately 20 seconds.
  - (20) Press STOP TEST button on Transponder Test Set, IFR6000.
- D. Transponder-2 MODE A,C,S Test using Transponder Test Set, IFR6000
- (1) Relocate to Antenna Coupler to Transponder 2 Antenna located in the Center Belly.
  - (2) Power Up: Press the POWER Key to power the Test Set.
  - (3) Press SETUP Control Key to display setup screens. Continue pressing SETUP Control Key to cycle to SETUPXPDR Screen. Use NEXT PARAM and PREV PARAM Soft Keys to select each parameter.
  - (4) Select RF PORT: Select DIR W/COUPLER
    - (a) Select CPL CABLE LOSS: Set to loss found on cable.
    - (b) Select COUPLER LOSS: Set to loss found on coupler.
  - (5) On left PFD use lower right softkey to scroll to XPDR, press ACTIVE softkey (upper right button) on the left PFD to select XPDR2.
  - (6) Press MODE softkey button on the Left PFD to select ON
  - (7) Press XPDR button to go to the XPDR AUTO TEST page.
  - (8) Press CONFIG button. On the CONFIG line, scroll to GENERIC MODE S using the up/down buttons and press the Return button and select RUN TEST, found on display screen.
    - Bottom ERP dBm should be between 48 to 60 and MTL dBm should be between -67 to -79 to PASS.
  - (9) If values are obtained and test FAILS, press TEST LIST button on IFR 6000 and using the up/down buttons, scroll to the specific failed test. Press SELECT TEST button, adjust IFR antenna and press RUN TEST button until PASS message appears
- NOTE: This may take several adjustments until IFR 6000 and aircraft Transponder SYNC UP.

- (10) Press STOP TEST button.
  - (11) Repeat until all FAILED tests have been completed.
  - (12) Press Return button on IFR 6000 to return to XPDR-AUTO TEST screen appears.
    - A PASS message should appear.
  - (13) On left PFD press MODE softkey to change the mode to ALT.
  - (14) CODE status box on the Left PFD and Right PFD show 1200.
  - (15) Press RUN TEST button on Transponder Test Set, IFR6000.  
Transponder Test Set, IFR6000 indicates:
    - “A Code” = 1200
    - “C Alt” = Reading within +/- 100 ft. of the right PFD altitude reading
  - (16) On Transponder Test Set, IFR6000, press XPDR button one time. Check that the following is displayed:
    - XPDR – ALT ENCODER
  - (17) On Transponder Test Set, IFR6000, press SOURCE SELECT button. Check that the following is displayed:
    - SOURCE: XPDR
  - (18) On Transponder Test Set, IFR6000, select RUN TEST.  
NOTE: Wait approximately 30 seconds between cockpit IDENT Tests
  - (19) Press IDNT key on the pilot’s keyboard.
    - IDENT is displayed on Transponder Test Set, IFR6000.NOTE: IDENT will disappear from the IFR test set in approximately 20 seconds.
  - (20) Press IDNT key on the Copilot’s keyboard. (If Installed)
    - IDENT is displayed on Transponder Test Set, IFR6000.NOTE: IDENT will disappear from the IFR test set in approximately 20 seconds.
  - (21) Press IDNT button on the Pilot’s Stick Grip.
    - IDENT is displayed on Transponder Test Set, IFR6000.NOTE: IDENT will disappear from the IFR test set in approximately 20 seconds.
  - (22) Press IDNT button on the Copilot’s Stick Grip.
    - IDENT is displayed on Transponder Test Set, IFR6000.NOTE: IDENT will disappear from the IFR test set in approximately 20 seconds.
  - (23) Press STOP TEST button on Transponder Test Set, IFR6000.
- E. Generic Mode S Test
- (1) Press STOP TEST button on Transponder Test Set, IFR6000.
  - (2) Make sure XPDR is still in MODE ALT on Left PFD.

- (3) On Transponder Test Set, IFR6000, select XPDR button. On CONFIG line, scroll using up/down buttons to GENERIC MODE S. Press Return button.
- (4) On Transponder Test Set, IFR6000, select Run Test. Expected results are as follows:
  - PASS, displayed on Transponder Test Set, IFR6000
  - the tail number listed on the test set matches the aircraft tail number

NOTE: If the tail number is not displayed, refer to [SUBTASK AMM-34-50-20-071-A-701-002](#).
- (5) Scroll to XPDR on Left PFD, Press the MODE softkey button to change the mode to STBY.
- (6) On Transponder Test Set, IFR6000, select Run Test.
  - Check that the NO REPLY message appears on upper section of Transponder Test Set, IFR6000.

## 5. Job Set-Up with IFR-6000 Test Antenna

SUBTASK AMM-34-50-20-071-A-921-001-B

- A. Make aircraft safe for maintenance. Refer to [AMM-20-00-01-051-801 – Make Safe For Maintenance](#).
- B. If on jacks, refer to [AMM-07-10-00-051-801 – Jacking - Maintenance Practices](#) and [AMM-08-20-00-051-801 – Leveling](#).
- C. Connect external power. Refer to [AMM-24-40-00-051-801 – External Power - Maintenance Practices](#). Do not turn on START BATT and SYS BATT switches until prompted.
- D. Prepare Anti-ice system for maintenance. Refer to [AMM-20-00-03-051-801 – Prepare Anti-Ice Systems For Maintenance](#).
- E. Take proper safety precautions to protect personnel. Position aircraft such that multi-path RF reflections between the IFR-6000 test set, the aircraft's antennas, and surrounding objects are minimized. The area on the left side of the aircraft should not be up against a metal wall or another aircraft. If necessary, position the aircraft outside, away from metal buildings or other aircraft. Refer to [Fig. 501](#).

**CAUTION:** FAILURE TO COMPLY WITH THIS STEP AND CONTINUING WITH THIS PROCEDURE COULD IMPACT LOCAL AIRPORT TOWER OPERATIONS.

- F. If applicable, contact local airport tower to inform them a transponder test is being run at your location (inside or outside). Request appropriate squawk and allotted time to run test.

**NOTE:** If local airport tower is not informed, use code 1200.

- G. Attach test set antenna to Transponder Test Set using 1 foot long test set cable (blue cable, supplied if IFR6000 is used), connected to ANT port on tester.
- H. During testing, place the Transponder Test Set antenna approximately two feet to four feet forward and in line with right wing tip tank. May require periodic repositioning between two and four feet.
- I. Connect WOW Box or AMC to aircraft. Refer to [AMM-20-00-04-051-801 – Weight On Wheels \(WOW\) Box - Connect/Disconnect](#). Make sure switches are set to W-on-W.

---

**6. Procedure with IFR-6000 Test Set Antenna**

SUBTASK AMM-34-50-20-071-A-701-001-A

A. Do adjustment/test of the Transponder System as follows:

- (1) Perform job setup, refer to [SUBTASK AMM-34-50-20-071-A-921-001-B](#).
- (2) Push ECB BY SYSTEM soft key. Scroll to FLT CTRLS using outer knob. Push inner knob to select. Scroll to the listed ECB using outer knob and highlight. Push “COLLAR” Soft key. Press “CONFIRM COLLAR” soft key.
  - ECB - NOSE LDG GEAR (L AFT Bus)
  - ECB - L MAIN LDG GEAR (L AFT Bus)
  - ECB - R MAIN LDG GEAR (L AFT Bus)
- (3) Set WOW Box to W-off-W.

NOTE: Transponders only turn on with Weight-off-Wheels.

- (4) Set both left and right PFD baro set to 29.92 on Autopilot Control Panel (ACP) by pressing BARO SET knob.

B. Transponder-1 Setup using Transponder Test Set, IFR6000

- (1) Press the bottom right rocker switch on the left PFD to select XPDR.

NOTE: The XPDR select page times out and switches back to the COM page after 30 seconds. Select XPDR page from time to time during this test.
- (2) Press ACTIVE softkey (upper right button) on the left PFD to select XPDR1.
- (3) CODE status box on the left PFD and right PFD shows 1200.
  - (a) To change CODE, scroll to XPDR using softkey. Use outer knob to highlight and inner knob to change numeric values.
- (4) Press MODE softkey on the left PFD to select ON.
- (5) Press the bottom right rocker switch on the right PFD to select XPDR.

NOTE: The XPDR select page times out and switches back to the COM page after 30 seconds. Select XPDR page from time to time during this test.
- (6) Press ACTIVE softkey (upper right button) on the right PFD to select XPDR1.
- (7) Set CODE to 1300, scroll to XPDR using softkey, and use the outer knob to highlight and inner knob to change numeric values.
- (8) CODE status box on the Left PFD and Right PFD shows 1300.

NOTE: Upon completion of Right PFD test, return CODE to 1200.
- (9) Press MODE softkey on the right PFD to select ON.
- (10) Using the pilot’s keyboard, perform the following steps:
  - (a) Press XPDR1.
    - Keyboard XPDR1 LED is lit.
  - (b) Press ON.

- (c) Press XPDR SQWK.
- (d) Using the keyboard numbers, set the code to 1200.
- (e) Press Enter.
  - CODE status box on the left PFD shows 1200.

C. Transponder-1 MODE A,C,S Test using Transponder Test Set, IFR6000

- (1)
- (2) Power up the Transponder Test Set, IFR6000 and press SET UP button on the test set. Press XPDR to display AUTO TEST until XPDR-AUTO TEST is displayed. Using UP/DOWN buttons scroll to GENERIC MODE S press SET UP button on IFR 6000 to go to SET UP-XPDR display
  - Display shows: SETUP XPDR.
- (3) Use either PREV PARAM or NEXT PARAM button to highlight RF Port selection window. Using Up/Down arrow keys, select Antenna.
  - (a) Press NEXT PARAM to scroll to the TOP ANT RANGE and ANT HEIGHT.

NOTE: If the BOTTOM antenna is boxed, press XPDR button, then press Select Antenna. Use SELECT ANT button to toggle to TOP. Press SETUP button to return to previous screen.
  - (b) Enter estimated distance that the test set antenna is from the aircraft using up/down buttons.
  - (c) Press NEXT PARAM and enter estimated height of aircraft antenna from ground.
  - (d) Select NEXT PARAM until ANT CABLE LOSS is highlighted. Obtain cable loss value from cable running between antenna and Test set (denoted by Value followed by dB). Enter the data on Transponder Test Set, IFR6000.
  - (e) Press NEXT PARAM and enter the dBi value directly beneath the GHz values 1.03 and 1.09 from antenna data plate. Enter the data on Transponder Test Set, IFR6000.
- (4) Press XPDR button to go to the XPDR AUTO TEST page.
- (5) Press CONFIG button. On the CONFIG line, scroll to GENERIC MODE S using the up/down buttons. Press Return button and select Run Test, found on display screen.
  - Top ERP dBm should be between 48 to 60 and MTL. dBm should be between -67 to -79 to PASS.
- (6) If values are obtained and test FAILS, press TEST LIST button on IFR 6000 and, using up/down buttons, scroll to the specific failed test. Press SELECT TEST button, adjust IFR antenna, and press RUN TEST button until PASS message appears.

NOTE: This may take several adjustments until IFR 6000 and aircraft transponder SYNC UP.
- (7) Press STOP TEST button.
- (8) Repeat until all FAILED tests have been completed.
- (9) Press Return button on IFR 6000 to return to XPDR-AUTO. TEST screen appears.

- A PASS message should be displayed.

**NOTE:** If POWER/FREQ test fails, after pressing RUN TEST, adjust antenna until PASS message appears. Stop adjusting antenna as soon as PASS message appears and press STOP TEST button. This test performs a live update of the dBm values needed to achieve a PASS message for test.

- (10) On left PFD, scroll to XPDR using lower softkey.
  - (11) Press MODE softkey to change the mode to ALT.
  - (12) CODE status box on the left PFD and right PFD show 1200.
  - (13) Press RUN TEST button on Transponder Test Set, IFR6000.  
Transponder Test Set, IFR6000 indicates:
    - A Code = 1200
    - C Alt = Reading within +/- 100 ft. of the Left PFD altitude reading
  - (14) On Transponder Test Set, IFR6000, press XPDR button one time. Check that the following is displayed:
    - XPDR – ALT ENCODER
  - (15) On Transponder Test Set, IFR6000, press Source Select button. Check that the following is displayed:
    - SOURCE: XPDR
  - (16) On Transponder Test Set, IFR6000, select RUN TEST.  
**NOTE:** Wait approximately 30 Seconds between cockpit IDENT tests.
  - (17) Press IDNT key on the Pilot's keyboard.
    - IDENT is displayed on Transponder Test Set, IFR6000.**NOTE:** IDENT disappears from the IFR test set in approximately 20 seconds.
  - (18) Press IDNT key on the Copilot's keyboard (If Installed).
    - IDENT is displayed on Transponder Test Set, IFR6000.**NOTE:** IDENT disappears from the IFR test set in approximately 20 seconds.
  - (19) Press IDNT button on the Pilot's Stick Grip.
    - IDENT is displayed on Transponder Test Set, IFR6000.**NOTE:** IDENT disappears from the IFR test set in approximately 20 seconds.
  - (20) Press IDNT button on the Copilot's Stick Grip.
    - IDENT is displayed on Transponder Test Set, IFR6000.**NOTE:** IDENT disappears from the IFR test set in approximately 20 seconds.
  - (21) Press STOP TEST button on Transponder Test Set, IFR6000.
- D. Transponder-2 MODE A,C,S Test using Transponder Test Set, IFR6000
- (1) Realign the Transponder Test Set, IFR6000 flat plane antenna to point at the aircraft Transponder 2 Antenna located in the Center Belly.

- (2) Power up the Transponder Test Set, IFR6000 (if required), and press SET UP button one time on the test set, and press XPDR to display AUTO TEST until XPDR-AUTO TEST. Using up/down buttons, scroll to GENERIC MODE S press SET UP button on IFR 6000 to go to SET UP-XPDR display
  - Display shows SETUP XPDR.
- (3) Use either PREV PARAM or NEXT PARAM button to highlight RF Port: selection window. Using up/down arrow keys, select ANTENNA.
  - (a) Press NEXT PARAM to scroll to the TOP ANT RANGE and ANT HEIGHT.

**NOTE:** If BOTTOM antenna is boxed, press XPDR button, then press Select Antenna. Use the SELECT ANT button to toggle to TOP. Press Set-up button to return to previous screen.
  - (b) Enter estimated distance that the test set antenna is from the aircraft using up/down buttons.
  - (c) Press NEXT PARAM and enter estimated height of aircraft antenna from ground.
  - (d) Select NEXT PARAM until ANT CABLE LOSS is highlighted. Obtain cable loss value from cable running between antenna and Test set (denoted by value followed by dB). Enter the data on Transponder Test Set, IFR6000.
  - (e) Press NEXT PARAM and Enter the dBi value directly beneath the GHz values 1.03 and 1.09 from antenna data plate. Enter the data on Transponder Test Set, IFR6000:
- (4) On left PFD use lower right softkey to scroll to XPDR, press ACTIVE softkey (upper right button) on the left PFD to select XPDR2.
- (5) Press MODE softkey button on the Left PFD to select ON
- (6) Press XPDR button to go to the XPDR AUTO TEST page.
- (7) Press CONFIG button. On the CONFIG line, scroll to GENERIC MODE S using the up/down buttons and press the Return button and select RUN TEST, found on display screen.
  - Bottom ERP dBm should be between 48 to 60 and MTL dBm should be between -67 to -79 to PASS.
- (8) If values are obtained and test FAILS, press TEST LIST button on IFR 6000 and using the up/down buttons, scroll to the specific failed test. Press SELECT TEST button, adjust IFR antenna and press RUN TEST button until PASS message appears

**NOTE:** This may take several adjustments until IFR 6000 and aircraft Transponder SYNC UP.
- (9) Press STOP TEST button.
- (10) Repeat until all FAILED tests have been completed.
- (11) Press Return button on IFR 6000 to return to XPDR-AUTO TEST screen appears.

- A PASS message should appear.

NOTE: If POWER/FREQ test fails, after pressing RUN TEST, adjust Antenna until PASS message appears. Stop adjusting antenna as soon as PASS message appears and press STOP TEST button. This test performs a LIVE update of the dBm values needed to achieve a PASS message for test.

- (12) On left PFD press MODE softkey to change the mode to ALT.
- (13) CODE status box on the Left PFD and Right PFD show 1200.
- (14) Press RUN TEST button on Transponder Test Set, IFR6000.  
Transponder Test Set, IFR6000 indicates:
  - “A Code” = 1200
  - “C Alt” = Reading within +/- 100 ft. of the right PFD altitude reading
- (15) On Transponder Test Set, IFR6000, press XPDR button one time. Check that the following is displayed:
  - XPDR – ALT ENCODER
- (16) On Transponder Test Set, IFR6000, press SOURCE SELECT button. Check that the following is displayed:
  - SOURCE: XPDR
- (17) On Transponder Test Set, IFR6000, select RUN TEST.  
NOTE: Wait approximately 30 seconds between cockpit IDENT Tests
- (18) Press IDNT key on the pilot’s keyboard.
  - IDENT is displayed on Transponder Test Set, IFR6000.

NOTE: IDENT will disappear from the IFR test set in approximately 20 seconds.
- (19) Press IDNT key on the Copilot’s keyboard. (If Installed)
  - IDENT is displayed on Transponder Test Set, IFR6000.

NOTE: IDENT will disappear from the IFR test set in approximately 20 seconds.
- (20) Press IDNT button on the Pilot’s Stick Grip.
  - IDENT is displayed on Transponder Test Set, IFR6000.

NOTE: IDENT will disappear from the IFR test set in approximately 20 seconds.
- (21) Press IDNT button on the Copilot’s Stick Grip.
  - IDENT is displayed on Transponder Test Set, IFR6000.

NOTE: IDENT will disappear from the IFR test set in approximately 20 seconds.
- (22) Press STOP TEST button on Transponder Test Set, IFR6000.

#### E. Generic Mode S Test

- (1) Press STOP TEST button on Transponder Test Set, IFR6000.
- (2) Make sure XPDR is still in MODE ALT on Left PFD.

- (3) On Transponder Test Set, IFR6000, select XPDR button. On CONFIG line, scroll using up/down buttons to GENERIC MODE S. Press Return button.
- (4) On Transponder Test Set, IFR6000, select Run Test. Expected results are as follows:
  - PASS, displayed on Transponder Test Set, IFR6000
  - the tail number listed on the test set matches the aircraft tail number

NOTE: If the tail number is not displayed, refer to [SUBTASK AMM-34-50-20-071-A-701-002](#).
- (5) Scroll to XPDR on Left PFD, Press the MODE softkey button to change the mode to STBY.
- (6) On Transponder Test Set, IFR6000, select Run Test.
  - Check that the NO REPLY message appears on upper section of Transponder Test Set, IFR6000.

## **7. Transponder Address Module Programming Procedure**

SUBTASK AMM-34-50-20-071-A-701-002

- A. The 24-bit ICAO address is stored for the transponder in the Address Module PN: AM6400-1-(01).

Program the Transponder Address Module as follows:

- (1) Remove Transponder Address Module from back of PFD.
- (2) Use address module programmer kits AMP6400-1 (parallel interface) or AMP6400-2 (USB interface), along with a PC to program the Address Module.

NOTE: The CD-ROM, which is part of the address module programmer kit, includes the programming procedure. Insert the CD-ROM into a PC and follow the instructions. If autostart is disabled on your PC, you have to start "setup.exe" manually.

- (3) Reinstall Transponder Address Module on back of PFD.

## **8. Job Close-Up**

SUBTASK AMM-34-50-20-071-A-921-002

- A. Set WOW Box switches to W-on-W
- B. Reset the collared ECB's. Refer to AMM-20-00-03-051-801 – Prepare Anti-Ice Systems For Maintenance.
- C. Power down the aircraft by setting the SYS BATT and START BATT switches to OFF and the BUS TIE to OPEN.
- D. Disconnect WOW Box from aircraft. Refer to AMM-20-00-04-051-801 – Weight On Wheels (WOW) Box - Connect/Disconnect.
- E. Remove all tools, equipment and unwanted material from work area.

- F. Disconnect external power. Refer to [AMM-24-40-00-051-801 – External Power - Maintenance Practices](#).
- G. If all other maintenance is complete, return aircraft to service. Refer to [AMM-20-00-02-051-801 – Return To Service \(After Maintenance\)](#).

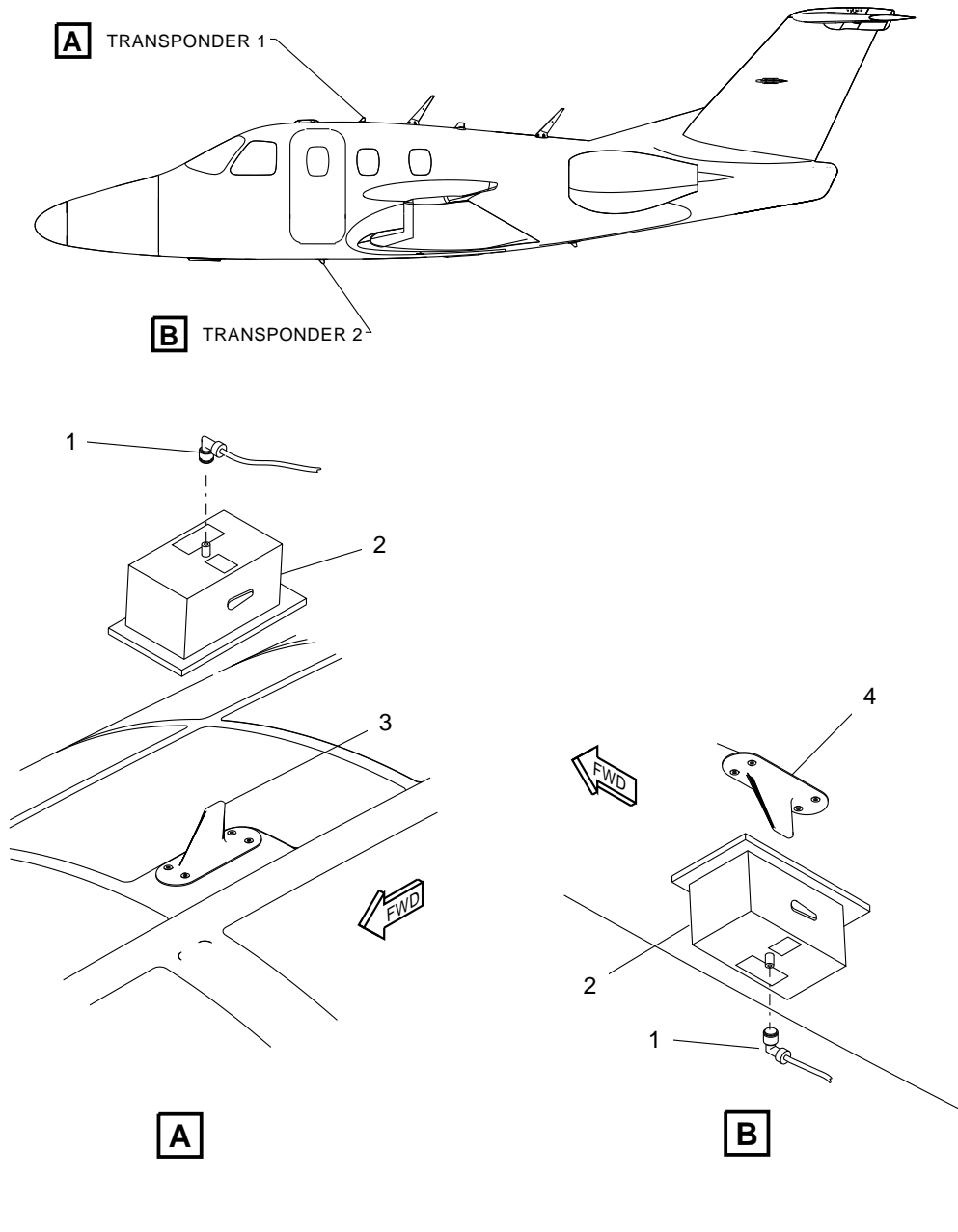

5202061A

**Transponder - Adjustment/Test  
Figure 501 (Sheet 1 of 1)**

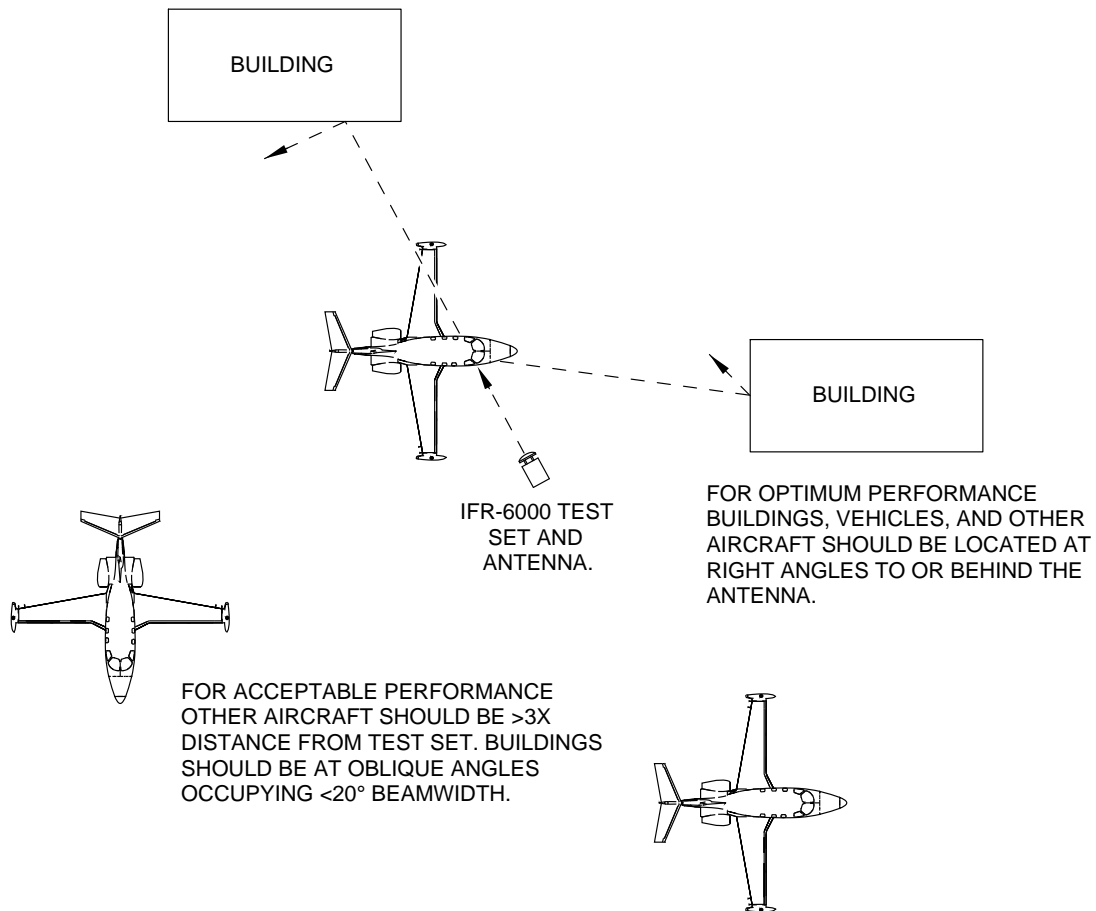
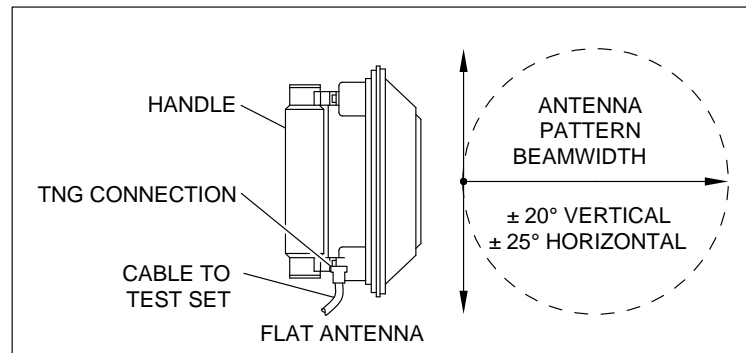

5081043A

**Transponder - Adjustment/Test  
Figure 502 (Sheet 1 of 1)**

### TRANSPONDER - ADJUSTMENT/TEST

AMM-34-50-20-071-B-801

#### 1. General

- A. This task gives procedures to do the adjustment/test of the:
- Dual Standard (Non-Diversity) Transponder System and components (or) Optional Dual Diversity Transponder System and components.
  - An adjustment/test is only required for the transponder that is being installed. The opposite transponder, if it has not been removed, does not require an adjustment/test
  - There are two testing methods, the preferred method is with the use of a transponder antenna coupler to limit emissions that may interfere with Air Traffic Control operations and the second method which uses the IFR-6000 antennas.
- (1) Refer to [Table 501](#) for testing procedures.

**Table 501. Test Matrix**

System Test	Procedures
Dual Standard Transponder System Test	<b>Std. Transponder 1 Adjustment/Test:</b> <a href="#">SUBTASK AMM-34-50-20-071-B-701-001-A</a> or <a href="#">SUBTASK AMM-34-50-20-071-B-701-001-B</a> , and <b>Std. Transponder 2 Adjustment/Test:</b> <a href="#">SUBTASK AMM-34-50-20-071-B-701-002-A</a> or <a href="#">SUBTASK AMM-34-50-20-071-B-701-002-B</a> . <b>Transponder Cooling Adjustment/Test:</b> <a href="#">TASK AMM-34-50-24-071-801</a> .
Dual Diversity Transponder System Test	<b>Diversity Transponder 1 Adjustment/Test:</b> <a href="#">SUBTASK AMM-34-50-20-071-B-701-003-A</a> or <a href="#">SUBTASK AMM-34-50-20-071-B-701-003-B</a> , and <b>Diversity Transponder 2 Adjustment/Test:</b> <a href="#">SUBTASK AMM-34-50-20-071-B-701-004-A</a> or <a href="#">SUBTASK AMM-34-50-20-071-B-701-004-B</a> . <b>Transponder Cooling Adjustment/Test:</b> <a href="#">TASK AMM-34-50-24-071-801</a> .

## 2. Equipment and Materials

**Table 502. Special Tools and Equipment**

Name and Part Number	
	Transponder Test Set (Aeroflex, IFR6000) or equivalent
	UC-584 Universal Transponder Antenna Coupler   Dual Antenna Kit (Viavi 112349)[1]
	Weight-on-Wheels (WOW) Box (EAI, 87-117390-1001) or AMC 2.4.01 (or higher).
	Ground Power Unit (GPU). AllStar 450 or AllStar G.S.E. or Hobart GPU-400 or Hobart GPU-600 or Bycan PS-28100

| [1] For test with UC-584 antenna coupler.

### 3. Job Set-Up with UC-584 Antenna Coupler

SUBTASK AMM-34-50-20-071-B-921-001-A

Refer to [Fig. 501](#).

- A. Make aircraft safe for maintenance. Refer to [AMM-20-00-01-051-801 – Make Safe For Maintenance](#).
- B. If on jacks, refer to [AMM-07-10-00-051-801 – Jacking - Maintenance Practices](#) and [AMM-08-20-00-051-801 – Leveling](#).
- C. Connect external power. Refer to [AMM-24-40-00-051-801 – External Power - Maintenance Practices](#). Do not turn on START BATT and SYS BATT switches until prompted.
- D. Prepare Anti-ice system for maintenance. Refer to [AMM-20-00-03-051-801 – Prepare Anti-Ice Systems For Maintenance](#).
- E. Connect Antenna Coupler UC-584S to Aircraft upper Transponder Antenna as follows: (as applicable)

NOTE: For Transponder–1 Adjustment/Test

- (1) Place Antenna Coupler (2) over the antenna (3), guiding antenna in to the slot on the bottom of the coupler.
- (2) Lock Antenna Coupler (2) into place by pushing lever on the side of the coupler into a down and locked position.

NOTE: Coupler must be tightly pressed and locked in place for Test Set to function correctly. Coupler will lock into place when the black rubber gasket is not completely depressed against the aircraft, but the Test Set will not measure functions accurately.

CAUTION: DO NOT CONNECT COAX CABLE TO IFR-6000 ANT PORT. DAMAGE TO EQUIPMENT WILL OCCUR.

- (3) Connect long RF coaxial cable (1) between the Antenna Coupler (2) and Test Set RF I/O Connector.

CAUTION: THE RF COAXIAL CABLE CAN BE A TRIPPING HAZARD. MAKE SURE TO SECURE THE CABLE. PERSONAL INJURY AND DAMAGE TO THE ANTENNAS AND TEST EQUIPMENT COULD OCCUR.

- (4) Temporarily secure the coaxial cable to the aircraft with tape. Tape can be removed after the test is completed.
  - (5) Push Antenna Coupler (2) firmly against the aircraft skin until the black rubber gasket on the rim of the coupler is completely depressed tightly against the aircraft.
- F. Connect Antenna Coupler UC-584 to Aircraft lower Transponder Antenna as follows: (as applicable)

NOTE: For Transponder–2 Adjustment/Test

- (1) Place Antenna Coupler (2) over the antenna (4) , guiding antenna in to the slot on the bottom of the coupler.
  - (2) Lock Antenna Coupler (2) into place by pushing lever on the side of the coupler into a down and locked position.  
**NOTE:** Antenna Coupler must be tightly pressed and locked in place for Test Set to function correctly. Coupler will lock into place when the black rubber gasket is not completely depressed against the aircraft, but the Test Set will not measure functions accurately.  
  
**CAUTION:** DO NOT CONNECT COAX CABLE TO IFR-6000 ANT PORT. DAMAGE TO EQUIPMENT WILL OCCUR.
  - (3) Connect long RF coaxial cable (1) between the Antenna Coupler and Test Set RF I/O Connector.  
  
**CAUTION:** THE RF COAXIAL CABLE CAN BE A TRIPPING HAZARD. MAKE SURE TO SECURE THE CABLE. PERSONAL INJURY AND DAMAGE TO THE ANTENNAS AND TEST EQUIPMENT COULD OCCUR.
  - (4) Temporarily secure the coaxial cable to the aircraft with tape. Tape can be removed after the test is completed.
  - (5) Push Antenna Coupler (2) firmly against the aircraft skin until the black rubber gasket on the rim of the coupler is completely depressed tightly against the aircraft.
- G. Connect Weight On Wheels (WOW) box or Aircraft Maintenance Computer (AMC) and set switches on Box to W-On-W (on-ground). Refer to [AMM-20-00-04-051-801 – Weight On Wheels \(WOW\) Box - Connect/Disconnect](#).

#### **4. Transponder-1 Adjustment/Test (Standard System) with UC-584 Antenna Coupler**

SUBTASK AMM-34-50-20-071-B-701-001-A

A. Begin adjustment/test as follows:

- (1) Perform Job Set-Up with UC-584 Antenna Coupler, refer to [SUBTASK AMM-34-50-20-071-B-921-001-A](#).
- (2) Use the small rotary knob on the left PFD to select XPDR page.  
**NOTE:** The XPDR select page will time out and switch back to the COM page after 30 seconds. The operator will have to select XPDR page from time to time during this test. Make sure that Transponder 1 (XPDR 1) is selected as ACTIVE transponder in STANDBY MODE.
- (3) Scroll to FLT CTRLS using outer knob. Push inner knob to select. Scroll to the listed ECB using outer knob and highlight. Push “COLLAR” soft key. Push “CONFIRM COLLAR” soft key.
  - ECB - NOSE LDG GEAR (L AFT Bus)
  - ECB - L MAIN LDG GEAR (L AFT Bus)
  - ECB - R MAIN LDG GEAR (L AFT Bus)
- (4) Scroll to ENGINE using outer knob. Push inner knob to select. Scroll to the listed ECB using outer knob and highlight. Push “COLLAR” soft key. Push “CONFIRM COLLAR” soft key.
  - ECB - L ENG FIRE EXTNGR (L FWD Bus)
  - ECB - R ENG FIRE EXTNGR (R FWD Bus)
- (5) Clear any “MASTER CAUTIONS” and “MASTER WARNINGS” as needed.
- (6) Set both left and right PFD baro set to 29.92 (in/Hg) on Autopilot Control Panel (ACP) by pushing BARO SET knob.

B. Transponder-1 Setup

- (1) Use the small rotary knob on the left PFD to select XPDR page.  
**NOTE:** The XPDR select page times out and switches back to the COM page after 30 seconds. Select XPDR page from time to time during this test.
- (2) Make sure that Transponder 1 (XPDR 1) is selected as ACTIVE transponder in STANDBY MODE.
- (3) Push CODE soft key on left PFD and enter the transponder code provided by the control tower for this test. If no code was assigned, enter 1200.

C. Transponder-1 MODE A,C,S Test using Transponder Test Set, IFR6000

- (1) Power up the Transponder Test Set (IFR 6000). After tester performs Self Test, push SETUP button on the test set to bring up the SETUP-XPDR page. If necessary, continue pressing SETUP button until tester cycles to SETUP-XPDR page.
- (2) On the Transponder Test Set (IFR 6000)'s SETUP-XPDR page, use NEXT PARAM or PREV PARAM soft keys to select each parameter, and the “arrow” DATA keys to set the values listed below.

- RF PORT: DIR W/COUPLER
  - CPL CABLE LOSS: Set to loss found on cable.
  - COUPLER LOSS: Set to loss found on coupler.
  - UUT ADDRESS: AUTO
  - MANUAL AA: Ignore
  - DIVERSITY TEST: OFF
  - CHECK CAP: YES
  - PWR LIM: FAR 43
  - RAD47: OFF.
- (3) Push XPDR button to go to the XPDR-AUTO TEST page.
- (4) Push CONFIG soft key to display the XPDR-CONFIG SCREEN page.
- (5) On the XPDR-CONFIG SCREEN, scroll to GENERIC MODE S using the UP/Down DATA keys.
- (6) With GENERIC MODE S highlighted, push RETURN soft key to confirm selection. This will also cause a return to the XPDR-AUTO TEST page.
- (7) Set the WOW test box or AMC to W-off-W.
- NOTE: Transponder will transition to ALT mode automatically when airborne or simulated airborne (W-off-W).
- (8) Push RUN TEST soft key to start AUTO TEST. The tester will sequence through separate tests, after which a "PASS" message should be displayed.
- (9) Top ERP should be between 48 to 60 dBm and MTL should be between -68 to -80 dBm to PASS.
- (10) Push RUN TEST soft key on Transponder Test Set (IFR 6000) again.
- (11) Make sure the following appears on the Transponder Test Set (IFR 6000):
- "A CODE" = transponder code entered
  - "C ALT" = left PFD altitude indication +/- 100 ft.
  - "S CODE" = ICAO code assigned to this aircraft/tail number
  - "TAIL" = tail number assigned to this aircraft
  - DF17 DETECTED = YES (IF ADS-B OUT IS INSTALLED) / NO (IF ADS-B OUT IS NOT INSTALLED)
  - "FLT ID" = same as tail number
  - "AA" = ICAO code assigned to this aircraft/tail number (8 digit number in parenthesis)
  - "FS" = IN-AIR
  - "VS" = IN-AIR

- 
- (12) On MFD, press SYS along bottom of MFD. Use the small lower knob on the MFD to scroll to the SETUP page. On the SETUP page, press the SETTINGS softkey to bring up the SETTINGS page. At the bottom of the SETTINGS page, check:
    - (a) The “REGISTRATION NO” number (alphanumeric) matches the “TAIL” number (alphanumeric) displayed on the IFR 6000 (above).
  - (13) The “ICAO 24-BIT (OCT)” number matches the “AA” ICAO 24-bit code displayed on the IFR 6000 (above).

**NOTE:** If the aircraft’s registration number and/or ICAO 24-bit (octal) number are not present on the MFD’s SETTINGS page, the Aircraft Configuration File must be updated, refer to [AMM-31-40-00-051-801 – Aircraft Computer Systems - Maintenance Practices](#). Steps (15) through this step must then be repeated.
  - (14) On the MFD, scroll to the SETUP tab, press the SENSOR Soft Key.
  - (15) Set the ADC PFD source selection from AUTO to ADC 2.
  - (16) On the IFR 6000, press the XPDR button once. Once XPDR – ALT ENCODER is displayed, press the SOURCE SELECT Soft Key until SOURCE - XPDR is displayed. Press the RUN TEST Soft Key.
  - (17) Make sure that an altitude reported on IFR 6000 matches L PFD altitude indication +/- 100 ft.
  - (18) On the MFD, set the ADC source back to AUTO.
  - (19) Set the WOW Box Switches to W-on-W (on-ground).
  - (20) Set XPDR 1 to STANDBY MODE.

## 5. Transponder-2 Adjustment/Test (Standard System) with UC-584 Antenna Coupler

SUBTASK AMM-34-50-20-071-B-701-002-A

A. Begin adjustment/test as follows:

- (1) Perform Job Set-Up with UC-584 Antenna Coupler, refer to [SUBTASK AMM-34-50-20-071-B-921-001-A](#).
- (2) Re-align the Transponder Test Set, IFR6000 antenna to point at the aircraft's lower Transponder-2 antenna (bottom of the center cabin/fuselage).
- (3) Place WOW box switches to W-on-W (on ground).
- (4) Use the small rotary knob on the left PFD to select XPDR page.

NOTE: The XPDR select page will time out and switch back to the COM page after 30 seconds. The operator will have to select XPDR page from time to time during this test.

- (5) Push ACTIVE soft key, upper right button, on the left PFD to select XPDR 2.
  - (a) Make sure that Transponder 2 (XPDR 2) is in STANDBY MODE.

B. Transponder-2 Setup

- (1) Push CODE soft key on right PFD and enter the transponder code provided by the control tower for this test. If no code was assigned, enter 1200.

C. Transponder-2 MODE A,C,S Test using Transponder Test Set, IFR6000

- (1) Power up the Transponder Test Set (IFR 6000). After tester performs Self Test, push SETUP button on the test set to bring up the SETUP-XPDR page. If necessary, continue pressing SETUP button until tester cycles to SETUP-XPDR page.
- (2) On the Transponder Test Set (IFR 6000) SETUP-XPDR page, use NEXT PARAM or PREV PARAM soft keys to select each parameter, and the "arrow" DATA keys to set the values listed below.
  - RF PORT: DIR W/COUPLER
  - CPL CABLE LOSS: Set to loss found on cable.
  - COUPLER LOSS: Set to loss found on coupler.
  - UUT ADDRESS: AUTO
  - MANUAL AA: Ignore
  - DIVERSITY TEST: OFF
  - CHECK CAP: YES
  - PWR LIM: FAR 43
  - RAD47: OFF.
- (3) Push XPDR button to go to the XPDR-AUTO TEST page.
- (4) Push CONFIG soft key to display the XPDR-CONFIG SCREEN page.
- (5) On the XPDR-CONFIG SCREEN, scroll to GENERIC MODE S using the up/down DATA keys.

- (6) With GENERIC MODE S highlighted, push RETURN soft key to confirm selection. This will also cause a return to the XPDR-AUTO TEST page.
- (7) Set the WOW Box Switches to W-off-W (airborne).
- (8) Push RUN TEST soft key to start AUTO TEST. The tester will sequence through separate tests, after which a “PASS” message should be displayed.
- (9) Bottom ERP should be between 48 to 60 dBm and MTL should be between -68 to -80 dBm to PASS.
- (10) Make sure the following appears on the Transponder Test Set (IFR 6000):
  - “A CODE” = transponder code entered
  - “C ALT” = left PFD altitude indication +/- 100 ft.
  - “S CODE” = ICAO code assigned to this aircraft/tail number
  - “TAIL” = tail number assigned to this aircraft
  - “FLT ID” = same as tail number
  - DF17 DETECTED” = YES (IF ADS-B OUT IS INSTALLED) / NO (IF ADS-B OUT IS NOT INSTALLED)
  - “AA” = ICAO code assigned to this aircraft/tail number (8 digit number in parenthesis)
  - “FS” = IN-AIR
  - “VS” = IN-AIR
- (11) On MFD, press SYS along bottom of MFD. Use the small lower knob on the MFD to scroll to the SETUP page. On the SETUP page, press the SETTINGS softkey to bring up the SETTINGS page. At the bottom of the SETTINGS page, check:
  - (a) The “REGISTRATION NO” number (alphanumeric) matches the “TAIL” number (alphanumeric) displayed on the IFR 6000 (above).
- (12) The “ICAO 24-BIT (OCT)” number matches the “AA” ICAO 24-bit code displayed on the IFR 6000 (above).

**NOTE:** If the aircraft’s registration number and/or ICAO 24-bit (octal) number are not present on the MFD’s SETTINGS page, the Aircraft Configuration File must be updated, refer to [AMM-31-40-00-051-801 – Aircraft Computer Systems - Maintenance Practices](#).
- (13) On the MFD, scroll to the SETUP tab, press the SENSOR Soft Key. Set the ADC PFD source selection from AUTO to ADC 2.
- (14) On the IFR 6000, press the XPDR button once.
- (15) Once XPDR – ALT ENCODER is displayed, press the SOURCE SELECT Soft Key until SOURCE - XPDR is displayed. Press the RUN TEST Soft Key.
- (16) Make sure an altitude reported on IFR 6000 matches L PFD altitude indication +/- 100 ft.
- (17) On the MFD, set the ADC source back to AUTO.
- (18) Set the WOW Box Switches to W-on-W (on-ground).

- (19) Set XPDR 2 to STANDBY MODE.

## 6. Diversity Transponder-1 Adjustment/Tests with UC-584 Antenna Coupler

SUBTASK AMM-34-50-20-071-B-701-003-A

### A. Begin adjustment/test as follows:

- (1) Install Antenna Clamp and Shield Assembly (part of Transponder Test Set IFR 6000) on lower transponder antenna (bottom of the center cabin/fuselage), in accordance with instructions in IFR 6000 Ramp Test Set Operation Manual.
  - (a) Position Antenna Clamp inside the slot in the Antenna Shield Plate, aligning captive screws into the respective screw holes.
  - (b) Tighten captive screws.
  - (c) Cover the transponder's Antenna with Antenna Shield. Loosen thumbscrews if necessary.

**NOTE:** It may be necessary to remove the unit under test's Antenna Guard if access to the transponders Antenna is restricted.
  - (d) Secure Antenna Shield by tightening thumbscrews.
- (2) Perform Job Set-Up with UC-584 Antenna Coupler, refer to [SUBTASK AMM-34-50-20-071-B-921-001-A](#).
- (3) Push ECB BY SYSTEM soft key. Scroll to FLCS using outer knob. Push inner knob to select. Scroll to the listed ECB using outer knob and highlight. Push "COLLAR" soft key. Push "CONFIRM COLLAR" soft key.
  - ECB - NOSE LDG GEAR (L AFT Bus)
  - ECB - L MAIN LDG GEAR (L AFT Bus)
  - ECB - R MAIN LDG GEAR (L AFT Bus)
- (4) Scroll to ENGINE using outer knob. Push inner knob to select. Scroll to the listed ECB using outer knob and highlight. Push "COLLAR" soft key. Push "CONFIRM COLLAR" soft key.
  - ECB - L ENG FIRE EXTNGR (L FWD Bus)
  - ECB - R ENG FIRE EXTNGR (R FWD Bus)
- (5) Clear any "MASTER CAUTIONS" and "MASTER WARNINGS" as needed.
- (6) Set both left and right PFD baro set to 29.92 (in/Hg.) on Autopilot Control Panel (ACP) by pushing BARO SET knob.
  - Make sure Baro Set on PFD annunciates "29.92 IN".

### B. Diversity Transponder-1 Setup

- (1) Use the small rotary knob on the left PFD to select XPDR page.

**NOTE:** The XPDR select page times out and switches back to the COM page after 30 seconds. Select XPDR page from time to time during this test.
- (2) Push ACTIVE soft key (upper right button) on the left PFD to select D-XPDR1.

- (3) Make sure that the selected transponder is in Standby Mode.
  - (4) Push CODE soft key on left PFD and enter the transponder code used for this test or 1200.
- C. Diversity Transponder-1 MODE A,C,S Test using Transponder Test Set, IFR6000 (Upper Antenna)
- (1) Power up the Transponder Test Set (IFR 6000). After tester performs Self Test, push SETUP button on the test set to bring up the SETUP-XPDR page. If necessary, continue pressing SETUP button until tester cycles to SETUP-XPDR page.
  - (2) On the Transponder Test Set (IFR 6000)'s SETUP-XPDR page, use NEXT PARAM or PREV PARAM soft keys to select each parameter, and the "arrow" DATA keys to set the values listed below.
    - ANTENNA: TOP
    - RF PORT: DIR W/COUPLER
    - CPL CABLE LOSS: Set to loss found on cable.
    - COUPLER LOSS: Set to loss found on coupler.
    - UUT ADDRESS: AUTO
    - MANUAL AA: Ignore
    - DIVERSITY TEST: ON
    - CHECK CAP: YES
    - PWR LIM: FAR 43
    - RAD47: OFF.
  - (3) Push XPDR button to go to the XPDR-AUTO TEST page.
  - (4) Push CONFIG soft key to display the XPDR-CONFIG SCREEN page.
  - (5) On the XPDR-CONFIG SCREEN, scroll to GENERIC MODE S using the UP/Down DATA keys.
  - (6) With GENERIC MODE S highlighted, push RETURN soft key to confirm selection. This will also cause a return to the XPDR-AUTO TEST page.
  - (7) Set the WOW Box Switches to W-off-W (airborne).
  - (8) Push RUN TEST soft key to start AUTO TEST. The tester will sequence through separate tests, after which a "PASS" message should be displayed.
  - (9) Top ERP should be between 48 to 60 dBm and MTL should be between -68 to -80 dBm to PASS.
  - (10) Make sure the following appears on the Transponder Test Set (IFR 6000):
    - "A CODE" = transponder code entered
    - "C ALT" = left PFD altitude indication +/- 100 ft.
    - "S CODE" = ICAO code assigned to this aircraft/tail number
    - "TAIL" = tail number assigned to this aircraft

- “FLT ID” = same as tail number
  - DF17 DETECTED” = YES (IF ADS-B OUT IS INSTALLED) / NO (IF ADS-B OUT IS NOT INSTALLED)
  - “AA” = ICAO code assigned to this aircraft/tail number (8 digit number in parenthesis)
  - “FS” = IN-AIR
  - “VS” = IN-AIR
- (11) On MFD, press SYS along bottom of MFD. Use the small lower knob on the MFD to scroll to the SETUP page. On the SETUP page, press the SETTINGS soft key to bring up the SETTINGS page. At the bottom of the SETTINGS page, verify:
- (a) The “REGISTRATION NO” number (alphanumeric) matches the “TAIL” number (alphanumeric) displayed on the IFR 6000 (above).
  - (b) The “ICAO 24-BIT (OCT)” number matches the “AA” ICAO 24-bit code displayed on the IFR 6000 (above).
- NOTE:** If the aircraft’s registration number and/or ICAO 24-bit (octal) number are not present on the MFD’s SETTINGS page, the Aircraft Configuration File must be updated, refer to [AMM-31-40-00-051-801 – Aircraft Computer Systems - Maintenance Practices](#). Steps (10) through this step must then be repeated.
- (12) On the MFD, scroll to the SETUP tab, press the SENSOR Soft Key. Set the ADC PFD source selection from AUTO to ADC 2.
- (13) On the IFR 6000, press the XPDR button once.
- (14) Once XPDR – ALT ENCODER is displayed, press the SOURCE SELECT Soft Key until SOURCE - XPDR is displayed. Press the RUN TEST Soft Key.
- (15) Make sure that an altitude reported on IFR 6000 matches L PFD altitude indication +/- 100 ft.
- (16) On the MFD, set the ADC source back to AUTO.
- (17) Set the WOW Box Switches to W-on-W (on-ground).
- (18) Set D-XPDR 1 to STANDBY MODE.
- D. Diversity Transponder-1 MODE A,C,S Test using Transponder Test Set (IFR 6000) (Lower Antenna)
- (1) Remove Antenna Clamp and Shield Assembly (part of Transponder Test Set IFR 6000) from lower transponder antenna (bottom center cabin/fuselage).
  - (2) Remove CU-584S Antenna Coupler from upper transponder antenna.
  - (3) Install Antenna Clamp and Shield Assembly (part of Transponder Test Set IFR 6000) on upper transponder antenna (top of the center cabin/fuselage), in accordance with instructions in IFR 6000 Ramp Test Set Operation Manual.
  - (4) Install CU-584 Antenna Coupler on lower transponder antenna. Refer to Job Set-Up with UC-584 Antenna Couplers [SUBTASK AMM-34-50-20-071-921-001-A](#).
  - (5) Push XPDR button to go to the XPDR-AUTO TEST page.

- (6) Push CONFIG soft key to display the XPDR-CONFIG SCREEN page.
- (7) On the XPDR-CONFIG SCREEN, scroll to GENERIC MODE S using the UP/Down DATA keys.
- (8) With GENERIC MODE S highlighted, push RETURN soft key to confirm selection. This will also cause a return to the XPDR-AUTO TEST page.
- (9) Set the WOW Box Switches to W-off-W (airborne).
- (10) Push RUN TEST soft key to start AUTO TEST. The tester will sequence through separate tests, after which a "PASS" message should be displayed.
- (11) ERP should be between 48 to 60 dBm and MTL should be between -68 to -80 dBm to PASS.
- (12) Remove Antenna Clamp and Shield Assembly.
- (13) Remove CU-584 Antenna Coupler from lower transponder antenna.
- (14) Set the WOW Box Switches to W-on-W (on-ground).

## 7. Diversity Transponder-2 Adjustment/Tests with UC-584 Antenna Coupler

SUBTASK AMM-34-50-20-071-B-701-004-A

### A. Begin adjustment/test as follows:

- (1) Install Antenna Clamp and Shield Assembly (part of Transponder Test Set IFR 6000) on lower transponder antenna (bottom of the center cabin/fuselage), in accordance with instructions in IFR 6000 Ramp Test Set Operation Manual.
  - (a) Position Antenna Clamp inside the slot in the Antenna Shield Plate, aligning captive screws into the respective screw holes.
  - (b) Tighten captive screws.
  - (c) Cover the transponder's Antenna with Antenna Shield. Loosen thumbscrews if necessary.

**NOTE:** It may be necessary to remove the unit under test's Antenna Guard if access to the transponders Antenna is restricted.
  - (d) Secure Antenna Shield by tightening thumbscrews.
- (2) Perform Job Setup with UC-584 Antenna Coupler, refer to [SUBTASK AMM-34-50-20-071-B-921-001-A](#).
- (3) Push ECB BY SYSTEM soft key. Scroll to FLCSS using outer knob. Push inner knob to select. Scroll to the listed ECB using outer knob and highlight. Push "COLLAR" soft key. Push "CONFIRM COLLAR" soft key.
  - ECB - NOSE LDG GEAR (L AFT Bus)
  - ECB - L MAIN LDG GEAR (L AFT Bus)
  - ECB - R MAIN LDG GEAR (L AFT Bus)
- (4) Scroll to ENGINE using outer knob. Push inner knob to select. Scroll to the listed ECB using outer knob and highlight. Push "COLLAR" soft key. Push "CONFIRM COLLAR" soft key.
  - ECB - L ENG FIRE EXTNGR (L FWD Bus)
  - ECB - R ENG FIRE EXTNGR (R FWD Bus)
- (5) Clear any "MASTER CAUTIONS" and "MASTER WARNINGS" as needed.
- (6) Set both left and right PFD baro set to 29.92 (in/Hg.) on Autopilot Control Panel (ACP) by pushing BARO SET knob.
  - Make sure Baro Set on PFD annunciates "29.92 IN".

### B. Diversity Transponder-2 Setup

- (1) Use the small rotary knob on the left PFD to select XPDR page.

**NOTE:** The XPDR select page times out and switches back to the COM page after 30 seconds. Select XPDR page from time to time during this test.
- (2) Push ACTIVE soft key (upper right button) on the left PFD to select D-XPDR2.
- (3) Make sure that D-XPDR2 is in Standby Mode.

- 
- (4) Push CODE soft key on left PFD and enter the transponder code used for this test or 1200.
- C. Diversity Transponder-2 MODE A,C,S Test using Transponder Test Set, IFR6000 (Upper Antenna)
- (1) Power up the Transponder Test Set (IFR 6000). After tester performs Self Test, push SETUP button on the test set to bring up the SETUP-XPDR page. If necessary, continue pressing SETUP button until tester cycles to SETUP-XPDR page.
- (2) On the Transponder Test Set (IFR 6000)'s SETUP-XPDR page, use NEXT PARAM or PREV PARAM soft keys to select each parameter, and the "arrow" DATA keys to set the values listed below.
- ANTENNA: BOTTOM
  - RF PORT: DIR W/COUPLER
  - CPL CABLE LOSS: Set to loss found on cable.
  - COUPLER LOSS: Set to loss found on coupler.
  - UUT ADDRESS: AUTO
  - MANUAL AA: Ignore
  - DIVERSITY TEST: ON
  - CHECK CAP: YES
  - PWR LIM: FAR 43
  - RAD47: OFF.
- (3) Push XPDR button to go to the XPDR-AUTO TEST page.
- (4) Push CONFIG soft key to display the XPDR-CONFIG SCREEN page.
- (5) On the XPDR-CONFIG SCREEN, scroll to GENERIC MODE S using the UP/Down DATA keys.
- (6) With GENERIC MODE S highlighted, push RETURN soft key to confirm selection. This will also cause a return to the XPDR-AUTO TEST page.
- (7) Set the WOW Box Switches to W-off-W (airborne).
- (8) Push RUN TEST soft key to start AUTO TEST. The tester will sequence through separate tests, after which a "PASS" message should be displayed.
- (9) Top ERP should be between 48 to 60 dBm and MTL should be between -68 to -80 dBm to PASS.
- (10) Make sure the following appears on the Transponder Test Set (IFR 6000):
- "A CODE" = transponder code entered
  - "C ALT" = left PFD altitude indication +/- 100 ft.
  - "S CODE" = ICAO code assigned to this aircraft/tail number
  - "TAIL" = tail number assigned to this aircraft

- “DF17 DETECTED” = YES (IF ADS-B OUT IS INSTALLED) / NO (IF ADS-B OUT IS NOT INSTALLED)
  - “FLT ID” = same as tail number
  - “AA” = ICAO code assigned to this aircraft/tail number (8 digit number in parenthesis)
  - “FS” = IN-AIR
  - “VS” = IN-AIR
- (11) On MFD, press SYS along bottom of MFD. Use the small lower knob on the MFD to scroll to the SETUP page. On the SETUP page, press the SETTINGS softkey to bring up the SETTINGS page. At the bottom of the SETTINGS page, verify:
- (a) The “REGISTRATION NO” number (alphanumeric) matches the “TAIL” number (alphanumeric) displayed on the IFR 6000 (above).
  - (b) The “ICAO 24-BIT (OCT)” number matches the “AA” ICAO 24-bit code displayed on the IFR 6000 (above).
- NOTE:** If the aircraft’s registration number and/or ICAO 24-bit (octal) number are not present on the MFD’s SETTINGS page, the Aircraft Configuration File must be updated, refer to [AMM-31-40-00-051-801 – Aircraft Computer Systems - Maintenance Practices](#). Steps (10) through this step must then be repeated.
- (12) On the MFD, scroll to the SETUP tab, press the SENSOR Soft Key. Set the ADC PFD source selection from AUTO to ADC 2.
- (13) On the IFR 6000, press the XPDR button once.
- (14) Once XPDR – ALT ENCODER is displayed, press the SOURCE SELECT Soft Key until SOURCE - XPDR is displayed. Press the RUN TEST Soft Key.
- (15) Make sure that an altitude reported on IFR 6000 matches L PFD altitude indication +/- 100 ft.
- (16) On the MFD, set the ADC source back to AUTO.
- (17) Set the WOW Box Switches to W-on-W (on-ground).
- (18) Set D-XPDR 2 to STANDBY MODE.
- D. Diversity Transponder-2 MODE A,C,S Test using Transponder Test Set (IFR 6000) (Lower Antenna)
- (1) Remove Antenna Clamp and Shield Assembly (part of Transponder Test Set IFR 6000) from lower transponder antenna (bottom center cabin/fuselage).
  - (2) Remove CU-584S Antenna Coupler from upper transponder antenna.
  - (3) Install Antenna Clamp and Shield Assembly (part of Transponder Test Set IFR 6000) on upper transponder antenna (top of the center cabin/fuselage), in accordance with instructions in IFR 6000 Ramp Test Set Operation Manual.
  - (4) Install CU-584 Antenna Coupler on lower transponder antenna. Refer to Job Set-Up with UC-584 Antenna Couplers [SUBTASK AMM-34-50-20-071-921-001-A](#).
  - (5) Remove Antenna Clamp and Shield Assembly (part of Transponder Test Set IFR 6000) from lower transponder antenna (bottom of the center cabin/fuselage).

- (6) Install Antenna Clamp and Shield Assembly (part of Transponder Test Set IFR 6000) on upper transponder antenna (top of the center cabin/fuselage), in accordance with instructions in IFR 6000 Ramp Test Set Operation Manual.
- (7) Pre-position the Transponder Test Set IFR 6000 antenna to point at the aircraft's lower Transponder 2 antenna (bottom of the center cabin/fuselage).
- (8) On the Transponder Test Set (IFR 6000) SETUP-XPDR page, use NEXT PARAM or PREV PARAM softkeys to select each parameter, and the "arrow" DATA keys to set the values listed below:
  - ANTENNA: BOTTOM
  - RF PORT: DIR W/COUPLER
  - DIR CABLE LOSS: Ignore
  - CPL CABLE LOSS: Set to loss found on cable.
  - COUPLER LOSS: Set to loss found on coupler.
  - UUT ADDRESS: AUTO
  - MANUAL AA: Ignore
  - DIVERSITY TEST: ON
  - PWR LIM: FAR 43
  - CHECK CAP: YES
- (9) Push XPDR button to go to the XPDR-AUTO TEST page.
- (10) Push CONFIG soft key to display the XPDR-CONFIG SCREEN page.
- (11) On the XPDR-CONFIG SCREEN, scroll to GENERIC MODE S using the UP/Down DATA keys.
- (12) With GENERIC MODE S highlighted, push RETURN soft key to confirm selection. This will also cause a return to the XPDR-AUTO TEST page.
- (13) Set the WOW Box Switches to W-off-W (airborne).
- (14) Push RUN TEST soft key to start AUTO TEST. The tester will sequence through separate tests, after which a "PASS" message should be displayed.
- (15) Bottom ERP should be between 48 to 60 dBm and MTL should be between -68 to -80 dBm to PASS.
- (16) Remove Antenna Clamp and Shield Assembly from aircraft and stow in IFR 6000 ramp test set kit.
- (17) Remove CU-584 Antenna Coupler from lower transponder antenna.
- (18) Set the WOW Box Switches to W-on-W (on-ground).
- (19) Test complete, go to Job Close-up (

---

## 8. Job Set-Up with IFR-6000 Antenna

SUBTASK AMM-34-50-20-071-B-921-001-B

- A. Make aircraft safe for maintenance. Refer to [AMM-20-00-01-051-801 – Make Safe For Maintenance](#).
- B. If on jacks, refer to [AMM-07-10-00-051-801 – Jacking - Maintenance Practices](#) and [AMM-08-20-00-051-801 – Leveling](#).
- C. Connect external power. Refer to [AMM-24-40-00-051-801 – External Power - Maintenance Practices](#). Do not turn on START BATT and SYS BATT switches until prompted.
- D. Prepare Anti-ice system for maintenance. Refer to [AMM-20-00-03-051-801 – Prepare Anti-Ice Systems For Maintenance](#).
- E. Take proper safety precautions to protect personnel. Position aircraft such that multi-path RF reflections between the IFR-6000 test set, the aircraft's antennas, and surrounding objects are minimized. The area on the left side of the aircraft should not be up against a metal wall or another aircraft. If necessary, position the aircraft outside, away from metal buildings or other aircraft. Refer to [Fig. 501](#).

**CAUTION:** FAILURE TO COMPLY WITH THIS STEP AND CONTINUING WITH THIS PROCEDURE COULD IMPACT LOCAL AIRPORT TOWER OPERATIONS.

- F. If applicable, contact local airport tower to inform them a transponder test is being run at your location (inside or outside). Request appropriate squawk and allotted time to run test.

**NOTE:** If local airport tower is not informed, use code 1200.

- G. Attach test set antenna to Transponder Test Set using 1 foot long test set cable (blue cable, supplied if IFR6000 is used), connected to ANT port on tester.
- H. During testing, place the Transponder Test Set antenna approximately two feet to four feet forward and in line with right wing tip tank. May require periodic repositioning between two and four feet.
- I. Connect Weight On Wheels (WOW) box or Aircraft Maintenance Computer (AMC) and set switches on Box to W-On-W. Refer to [AMM-20-00-04-051-801 – Weight On Wheels \(WOW\) Box - Connect/Disconnect](#).

---

**9. Transponder-1 Adjustment/Test (Standard System) with IFR-6000 Antenna**

SUBTASK AMM-34-50-20-071-B-701-001-B

A. Begin adjustment/test as follows:

(1) Perform job setup, refer to [SUBTASK AMM-34-50-20-071-B-921-001-B](#).

(2) Re-align the Transponder Test Set, IFR6000 antenna to point at the aircraft's Transponder-1 antenna (top of the center cabin/fuselage).

(3) Use the small rotary knob on the left PFD to select XPDR page.

NOTE: The XPDR select page will time out and switch back to the COM page after 30 seconds. The operator will have to select XPDR page from time to time during this test. Make sure that Transponder 1 (XPDR 1) is selected as ACTIVE transponder in STANDBY MODE.

(4) Scroll to FLT CTRLS using outer knob. Push inner knob to select. Scroll to the listed ECB using outer knob and highlight. Push "COLLAR" soft key. Push "CONFIRM COLLAR" soft key.

- ECB - NOSE LDG GEAR (L AFT Bus)
- ECB - L MAIN LDG GEAR (L AFT Bus)
- ECB - R MAIN LDG GEAR (L AFT Bus)

(5) Scroll to ENGINE using outer knob. Push inner knob to select. Scroll to the listed ECB using outer knob and highlight. Push "COLLAR" soft key. Push "CONFIRM COLLAR" soft key.

- ECB - L ENG FIRE EXTNGR (L FWD Bus)
- ECB - R ENG FIRE EXTNGR (R FWD Bus)

(6) Clear any "MASTER CAUTIONS" and "MASTER WARNINGS" as needed.

(7) Set both left and right PFD baro set to 29.92 (in/Hg) on Autopilot Control Panel (ACP) by pushing BARO SET knob.

B. Transponder-1 Setup

(1) Use the small rotary knob on the left PFD to select XPDR page.

NOTE: The XPDR select page times out and switches back to the COM page after 30 seconds. Select XPDR page from time to time during this test.

(2) Make sure that Transponder 1 (XPDR 1) is selected as ACTIVE transponder in STANDBY MODE.

(3) Push CODE soft key on left PFD and enter the transponder code provided by the control tower for this test. If no code was assigned, enter 1200.

C. Transponder-1 MODE A,C,S Test using Transponder Test Set, IFR6000

(1) Power up the Transponder Test Set (IFR 6000). After tester performs Self Test, push SETUP button on the test set to bring up the SETUP-XPDR page. If necessary, continue pressing SETUP button until tester cycles to SETUP-XPDR page.

- 
- (2) On the Transponder Test Set (IFR 6000)'s SETUP-XPDR page, use NEXT PARAM or PREV PARAM soft keys to select each parameter, and the "arrow" DATA keys to set the values listed below.
    - ANTENNA: TOP
    - RF PORT: ANTENNA
    - ANT RANGE-TOP: 18 ft.
    - ANT HEIGHT-TOP: 7 ft.
    - ANT RANGE-BOTTOM: 18 ft.
    - ANT HEIGHT-BOTTOM: 1 ft.
    - DIR CABLE LOSS: Ignore
    - ANT CABLE: 1 ft.
    - ANT CABLE LOSS: As marked on blue cable (should be 0.1 dB)
    - ANT GAIN (dBi) - 1.03 GHz: As marked on test set antenna
    - ANT GAIN (dBi) - 1.09 GHz: As marked on test set antenna
    - UUT ADDRESS: AUTO
    - MANUAL AA: Ignore
    - DIVERSITY TEST: OFF
    - PWR LIM: FAR 43
    - CHECK CAP: YES
  - (3) Push XPDR button to go to the XPDR-AUTO TEST page.
  - (4) Push CONFIG soft key to display the XPDR-CONFIG SCREEN page.
  - (5) On the XPDR-CONFIG SCREEN, scroll to GENERIC MODE S using the UP/Down DATA keys.
  - (6) With GENERIC MODE S highlighted, push RETURN soft key to confirm selection. This will also cause a return to the XPDR-AUTO TEST page.
  - (7) Set the WOW test box or AMC to W-off-W.

**NOTE:** Transponder will transition to ALT mode automatically when airborne or simulated airborne (W-off-W).
  - (8) Push RUN TEST soft key to start AUTO TEST. The tester will sequence through separate tests, after which a "PASS" message should be displayed.

- (9) Top ERP should be between 48 to 60 dBm and MTL should be between -68 to -80 dBm to PASS.

**NOTE:** If values are obtained and any of the individual tests FAIL during AUTO TEST, press TEST LIST button on IFR 6000 and using UP/DOWN buttons scroll to the specific Failed test(s). Press SELECT TEST button, adjust IFR 6000 test set positioning anywhere within a 30 foot arc between the aircraft's right wingtip and the nose as required, and Press RUN TEST button until PASS Message is received (this may take several test set position adjustments until IFR 6000 and aircraft Transponder "Sync up"). Press STOP TEST button. Repeat until all individual FAILED tests have achieved a PASS. It is not necessary to re-run AUTO TEST. AUTO TEST is a convenience feature only.

**NOTE:** If POWER/FREQ test Fails: After pressing RUN TEST, adjust IFR-6000 test set positioning while test is running until PASS message appears (this test performs a "Live" update of the dBm values). It may be required to position the test set anywhere within a 30 foot arc between the aircraft's right wingtip and the nose. Press the STOP TEST button as soon as PASS message is displayed

- (10) Push RUN TEST soft key on Transponder Test Set (IFR 6000) again.

- (11) Make sure the following appears on the Transponder Test Set (IFR 6000):

- "A CODE" = transponder code entered
- "C ALT" = left PFD altitude indication +/- 100 ft.
- "S CODE" = ICAO code assigned to this aircraft/tail number
- "TAIL" = tail number assigned to this aircraft
- DF17 DETECTED = YES (IF ADS-B OUT IS INSTALLED) / NO (IF ADS-B OUT IS NOT INSTALLED)
- "FLT ID" = same as tail number
- "AA" = ICAO code assigned to this aircraft/tail number (8 digit number in parenthesis)
- "FS" = IN-AIR
- "VS" = IN-AIR

- (12) On MFD, press SYS along bottom of MFD. Use the small lower knob on the MFD to scroll to the SETUP page. On the SETUP page, press the SETTINGS softkey to bring up the SETTINGS page. At the bottom of the SETTINGS page, check:

(a) The "REGISTRATION NO" number (alphanumeric) matches the "TAIL" number (alphanumeric) displayed on the IFR 6000 (above).

- (13) The "ICAO 24-BIT (OCT)" number matches the "AA" ICAO 24-bit code displayed on the IFR 6000 (above).

**NOTE:** If the aircraft's registration number and/or ICAO 24-bit (octal) number are not present on the MFD's SETTINGS page, the Aircraft Configuration File must be updated, refer to [AMM-31-40-00-051-801 – Aircraft Computer Systems - Maintenance Practices](#). Steps (15) through this step must then be repeated.

- | (14) On the MFD, scroll to the SETUP tab, press the SENSOR Soft Key.
- | (15) Set the ADC PFD source selection from AUTO to ADC 2.
- | (16) On the IFR 6000, press the XPDR button once. Once XPDR – ALT ENCODER is displayed, press the SOURCE SELECT Soft Key until SOURCE - XPDR is displayed. Press the RUN TEST Soft Key.
- | (17) Make sure that an altitude reported on IFR 6000 matches L PFD altitude indication +/- 100 ft.
- | (18) On the MFD, set the ADC source back to AUTO.
- | (19) Set the WOW Box Switches to W-on-W (on-ground).
- | (20) Set XPDR 1 to STANDBY MODE.

---

**10. Transponder-2 Adjustment/Test (Standard System) with IFR-6000 Antenna**

SUBTASK AMM-34-50-20-071-B-701-002-B

A. Begin adjustment/test as follows:

- (1) Perform job setup, refer to [SUBTASK AMM-34-50-20-071-B-921-001-B](#).
- (2) Re-align the Transponder Test Set, IFR6000 antenna to point at the aircraft's lower Transponder-2 antenna (bottom of the center cabin/fuselage).
- (3) Place WOW box switches to W-on-W (on ground).
- (4) Use the small rotary knob on the left PFD to select XPDR page.

NOTE: The XPDR select page will time out and switch back to the COM page after 30 seconds. The operator will have to select XPDR page from time to time during this test.

- (5) Push ACTIVE soft key, upper right button, on the left PFD to select XPDR 2.

- (a) Make sure that Transponder 2 (XPDR 2) is in STANDBY MODE.

B. Transponder-2 Setup

- (1) Push CODE soft key on right PFD and enter the transponder code provided by the control tower for this test. If no code was assigned, enter 1200.

C. Transponder-2 MODE A,C,S Test using Transponder Test Set, IFR6000

- (1) Power up the Transponder Test Set (IFR 6000). After tester performs Self Test, push SETUP button on the test set to bring up the SETUP-XPDR page. If necessary, continue pressing SETUP button until tester cycles to SETUP-XPDR page.
- (2) On the Transponder Test Set (IFR 6000) SETUP-XPDR page, use NEXT PARAM or PREV PARAM soft keys to select each parameter, and the "arrow" DATA keys to set the values listed below.
  - ANTENNA: BOTTOM
  - RF PORT: ANTENNA
  - ANT RANGE-TOP: 18 ft.
  - ANT HEIGHT-BOTTOM: 7 ft.
  - ANT RANGE-BOTTOM: 18 ft.
  - ANT HEIGHT-TOP: 1 ft.
  - DIR CABLE LOSS: Ignore
  - ANT CABLE: 1 ft.
  - ANT CABLE LOSS: As marked on blue cable (should be 0.1 dB)
  - ANT GAIN (dBi) - 1.03 GHz: As marked on test set antenna
  - ANT GAIN (dBi) - 1.09 GHz: As marked on test set antenna
  - UUT ADDRESS: AUTO
  - MANUAL AA: Ignore

- DIVERSITY TEST: OFF
- PWR LIM: FAR 43
- CHECK CAP: YES

- (3) Push XPDR button to go to the XPDR-AUTO TEST page.
- (4) Push CONFIG soft key to display the XPDR-CONFIG SCREEN page.
- (5) On the XPDR-CONFIG SCREEN, scroll to GENERIC MODE S using the up/down DATA keys.
- (6) With GENERIC MODE S highlighted, push RETURN soft key to confirm selection. This will also cause a return to the XPDR-AUTO TEST page.
- (7) Set the WOW Box Switches to W-off-W (airborne).
- (8) Push RUN TEST soft key to start AUTO TEST. The tester will sequence through separate tests, after which a “PASS” message should be displayed.
- (9) Bottom ERP should be between 48 to 60 dBm and MTL should be between -68 to -80 dBm to PASS.

**NOTE:** If values are obtained and any of the individual tests FAIL during AUTO TEST, press TEST LIST button on IFR 6000 and using UP/DOWN buttons scroll to the specific Failed test(s). Press SELECT TEST button, adjust IFR 6000 test set positioning anywhere within a 30 foot arc between the aircraft’s right wingtip and the nose as required, and Press RUN TEST button until PASS Message is received (this may take several test set position adjustments until IFR 6000 and aircraft Transponder “Sync up”). Press STOP TEST button. Repeat until all individual FAILED tests have achieved a PASS. It is not necessary to re-run AUTO TEST. AUTO TEST is a convenience feature only.

**NOTE:** If POWER/FREQ test Fails: After pressing RUN TEST, adjust IFR-6000 test set positioning while test is running until PASS message appears (this test performs a “Live” update of the dBm values). It may be required to position the test set anywhere within a 30 foot arc between the aircraft’s right wingtip and the nose. Press the STOP TEST button as soon as PASS message is displayed.

- (10) Make sure the following appears on the Transponder Test Set (IFR 6000):
  - “A CODE” = transponder code entered
  - “C ALT” = left PFD altitude indication +/- 100 ft.
  - “S CODE” = ICAO code assigned to this aircraft/tail number
  - “TAIL” = tail number assigned to this aircraft
  - “FLT ID” = same as tail number
  - “DF17 DETECTED” = YES (IF ADS-B OUT IS INSTALLED) / NO (IF ADS-B OUT IS NOT INSTALLED)
  - “AA” = ICAO code assigned to this aircraft/tail number (8 digit number in parenthesis)
  - “FS” = IN-AIR

- “VS” = IN-AIR
- (11) On MFD, press SYS along bottom of MFD. Use the small lower knob on the MFD to scroll to the SETUP page. On the SETUP page, press the SETTINGS softkey to bring up the SETTINGS page. At the bottom of the SETTINGS page, check:
    - (a) The “REGISTRATION NO” number (alphanumeric) matches the “TAIL” number (alphanumeric) displayed on the IFR 6000 (above).
  - (12) The “ICAO 24-BIT (OCT)” number matches the “AA” ICAO 24-bit code displayed on the IFR 6000 (above).

**NOTE:** If the aircraft’s registration number and/or ICAO 24-bit (octal) number are not present on the MFD’s SETTINGS page, the Aircraft Configuration File must be updated, refer to [AMM-31-40-00-051-801 – Aircraft Computer Systems - Maintenance Practices](#).
  - (13) On the MFD, scroll to the SETUP tab, press the SENSOR Soft Key. Set the ADC PFD source selection from AUTO to ADC 2.
  - (14) On the IFR 6000, press the XPDR button once.
  - (15) Once XPDR – ALT ENCODER is displayed, press the SOURCE SELECT Soft Key until SOURCE - XPDR is displayed. Press the RUN TEST Soft Key.
  - (16) Make sure an altitude reported on IFR 6000 matches L PFD altitude indication +/- 100 ft.
  - (17) On the MFD, set the ADC source back to AUTO.
- Set the WOW Box Switches to W-on-W (on-ground).
- (19) Set XPDR 2 to STANDBY MODE.

---

**11. Diversity Transponder–1 Adjustment/Tests with IFR-6000 Antenna**

SUBTASK AMM-34-50-20-071-B-701-003-B

**A. Begin adjustment/test as follows:**

(1) Install Antenna Clamp and Shield Assembly (part of Transponder Test Set IFR 6000) on lower transponder antenna (bottom of the center cabin/fuselage), in accordance with instructions in IFR 6000 Ramp Test Set Operation Manual.

(a) Position Antenna Clamp inside the slot in the Antenna Shield Plate, aligning captive screws into the respective screw holes.

(b) Tighten captive screws.

(c) Cover the transponder's Antenna with Antenna Shield. Loosen thumbscrews if necessary.

**NOTE:** It may be necessary to remove the unit under test's Antenna Guard if access to the transponders Antenna is restricted.

(d) Secure Antenna Shield by tightening thumbscrews.

(2) Perform job setup, refer to [SUBTASK AMM-34-50-20-071-B-921-001-B](#).

(3) Push ECB BY SYSTEM soft key. Scroll to FLCSS using outer knob. Push inner knob to select. Scroll to the listed ECB using outer knob and highlight. Push "COLLAR" soft key. Push "CONFIRM COLLAR" soft key.

- ECB - NOSE LDG GEAR (L AFT Bus)
- ECB - L MAIN LDG GEAR (L AFT Bus)
- ECB - R MAIN LDG GEAR (L AFT Bus)

(4) Scroll to ENGINE using outer knob. Push inner knob to select. Scroll to the listed ECB using outer knob and highlight. Push "COLLAR" soft key. Push "CONFIRM COLLAR" soft key.

- ECB - L ENG FIRE EXTNGR (L FWD Bus)
- ECB - R ENG FIRE EXTNGR (R FWD Bus)

(5) Clear any "MASTER CAUTIONS" and "MASTER WARNINGS" as needed.

(6) Set both left and right PFD baro set to 29.92 (in/Hg.) on Autopilot Control Panel (ACP) by pushing BARO SET knob.

- Make sure Baro Set on PFD annunciates "29.92 IN".

**B. Diversity Transponder-1 Setup**

(1) Use the small rotary knob on the left PFD to select XPDR page.

**NOTE:** The XPDR select page times out and switches back to the COM page after 30 seconds. Select XPDR page from time to time during this test.

(2) Push ACTIVE soft key (upper right button) on the left PFD to select D-XPDR1.

(3) Ensure the selected transponder is in Standby Mode.

- 
- (4) Push CODE soft key on left PFD and enter the transponder code used for this test or 1200.
  - (5) Make sure the selected transponder is in Standby Mode.
- C. Diversity Transponder-1 MODE A,C,S Test using Transponder Test Set, IFR6000 (Upper Antenna)
- (1) Power up the Transponder Test Set (IFR 6000). After tester performs Self Test, push SETUP button on the test set to bring up the SETUP-XPDR page. If necessary, continue pressing SETUP button until tester cycles to SETUP-XPDR page.
  - (2) On the Transponder Test Set (IFR 6000)'s SETUP-XPDR page, use NEXT PARAM or PREV PARAM soft keys to select each parameter, and the "arrow" DATA keys to set the values listed below.
    - ANTENNA: TOP
    - RF PORT: ANTENNA
    - ANT RANGE-TOP: 18 ft.
    - ANT HEIGHT-TOP: 7 ft.
    - ANT RANGE-BOTTOM: 18 ft.
    - ANT HEIGHT-BOTTOM: 1 ft.
    - DIR CABLE LOSS: Ignore
    - ANT CABLE: 1 ft.
    - ANT CABLE LOSS: As marked on blue cable (should be 0.1 dB)
    - ANT GAIN (dBi) - 1.03 GHz: As marked on test set antenna
    - ANT GAIN (dBi) - 1.09 GHz: As marked on test set antenna
    - UUT ADDRESS: AUTO
    - MANUAL AA: Ignore
    - DIVERSITY TEST: ON
    - PWR LIM: FAR 43
    - CHECK CAP: YES
  - (3) Push XPDR button to go to the XPDR-AUTO TEST page.
  - (4) Push CONFIG soft key to display the XPDR-CONFIG SCREEN page.
  - (5) On the XPDR-CONFIG SCREEN, scroll to GENERIC MODE S using the UP/Down DATA keys.
  - (6) With GENERIC MODE S highlighted, push RETURN soft key to confirm selection. This will also cause a return to the XPDR-AUTO TEST page.
  - (7) Set the WOW Box Switches to W-off-W (airborne).
  - (8) Push RUN TEST soft key to start AUTO TEST. The tester will sequence through separate tests, after which a "PASS" message should be displayed.

- (9) Top ERP should be between 48 to 60 dBm and MTL should be between -68 to -80 dBm to PASS.

**NOTE:** If values are obtained and any of the individual tests FAIL during AUTO TEST, press TEST LIST button on IFR 6000 and using UP/DOWN buttons scroll to the specific Failed test(s). Press SELECT TEST button, adjust IFR 6000 test set positioning anywhere within a 30 foot arc between the aircraft's right wingtip and the nose as required, and Press RUN TEST button until PASS Message is received (this may take several test set position adjustments until IFR 6000 and aircraft Transponder "Sync up"). Press STOP TEST button. Repeat until all individual FAILED tests have achieved a PASS. It is not necessary to re-run AUTO TEST. AUTO TEST is a convenience feature only.

**NOTE:** If POWER/FREQ test Fails: After pressing RUN TEST, adjust IFR-6000 test set positioning while test is running until PASS message appears (this test performs a "Live" update of the dBm values). It may be required to position the test set anywhere within a 30 foot arc between the aircraft's right wingtip and the nose. Press the STOP TEST button as soon as PASS message is displayed

- (10) Make sure the following appears on the Transponder Test Set (IFR 6000):

- "A CODE" = transponder code entered
- "C ALT" = left PFD altitude indication +/- 100 ft.
- "S CODE" = ICAO code assigned to this aircraft/tail number
- "TAIL" = tail number assigned to this aircraft
- "FLT ID" = same as tail number
- "DF17 DETECTED" = YES (IF ADS-B OUT IS INSTALLED) / NO (IF ADS-B OUT IS NOT INSTALLED)
- "AA" = ICAO code assigned to this aircraft/tail number (8 digit number in parenthesis)
- "FS" = IN-AIR
- "VS" = IN-AIR

- (11) On MFD, press SYS along bottom of MFD. Use the small lower knob on the MFD to scroll to the SETUP page. On the SETUP page, press the SETTINGS soft key to bring up the SETTINGS page. At the bottom of the SETTINGS page, check:

- (a) The "REGISTRATION NO" number (alphanumeric) matches the "TAIL" number (alphanumeric) displayed on the IFR 6000 (above).
- (b) The "ICAO 24-BIT (OCT)" number matches the "AA" ICAO 24-bit code displayed on the IFR 6000 (above).

**NOTE:** If the aircraft's registration number and/or ICAO 24-bit (octal) number are not present on the MFD's SETTINGS page, the Aircraft Configuration File must be updated, refer to [AMM-31-40-00-051-801 – Aircraft Computer Systems - Maintenance Practices](#). Steps (14) through this step must then be repeated.

- (12) On the MFD, scroll to the SETUP tab, press the SENSOR Soft Key. Set the ADC PFD source selection from AUTO to ADC 2.
  - (13) On the IFR 6000, press the XPDR button once.
  - (14) Once XPDR – ALT ENCODER is displayed, press the SOURCE SELECT Soft Key until SOURCE - XPDR is displayed. Press the RUN TEST Soft Key.
  - (15) Make sure an altitude reported on IFR 6000 matches L PFD altitude indication +/- 100 ft.
  - (16) On the MFD, set the ADC source back to AUTO.
  - (17) Set the WOW Box Switches to W-on-W (on-ground).
  - (18) Set D-XPDR 1 to STANDBY MODE.
- D. Diversity Transponder-1 MODE A,C,S Test using Transponder Test Set (IFR 6000) (Lower Antenna)
- (1) Remove Antenna Clamp and Shield Assembly (part of Transponder Test Set IFR 6000) from lower transponder antenna (bottom of the center cabin/fuselage).
  - (2) Install Antenna Clamp and Shield Assembly (part of Transponder Test Set IFR 6000) on upper transponder antenna (top of the center cabin/fuselage), in accordance with instructions in IFR 6000 Ramp Test Set Operation Manual.
  - (3) Pre-position the Transponder Test Set IFR 6000 antenna to point at the aircraft's lower Transponder 2 antenna (bottom of the center cabin/fuselage)..
  - (4) Push XPDR button to go to the XPDR-AUTO TEST page.
  - (5) Push CONFIG soft key to display the XPDR-CONFIG SCREEN page.
  - (6) On the XPDR-CONFIG SCREEN, scroll to GENERIC MODE S using the UP/Down DATA keys.
  - (7) With GENERIC MODE S highlighted, push RETURN soft key to confirm selection. This will also cause a return to the XPDR-AUTO TEST page.
  - (8) Set the WOW Box Switches to W-off-W (airborne).
  - (9) Push RUN TEST soft key to start AUTO TEST. The tester will sequence through separate tests, after which a "PASS" message should be displayed.

- 
- (10) Bottom ERP should be between 48 to 60 dBm and MTL should be between -68 to -80 dBm to PASS.

NOTE: If values are obtained and any of the individual tests FAIL during AUTO TEST, press TEST LIST button on IFR 6000 and using UP/DOWN buttons scroll to the specific Failed test(s). Press SELECT TEST button, adjust IFR 6000 test set positioning anywhere within a 30 foot arc between the aircraft's right wingtip and the nose as required, and Press RUN TEST button until PASS Message is received (this may take several test set position adjustments until IFR 6000 and aircraft Transponder "Sync up"). Press STOP TEST button. Repeat until all individual FAILED tests have achieved a PASS. It is not necessary to re-run AUTO TEST. AUTO TEST is a convenience feature only.

NOTE: If POWER/FREQ test Fails: After pressing RUN TEST, adjust IFR-6000 test set positioning while test is running until PASS message appears (this test performs a "Live" update of the dBm values). It may be required to position the test set anywhere within a 30 foot arc between the aircraft's right wingtip and the nose. Press the STOP TEST button as soon as PASS message is displayed

- (11) Remove Antenna Clamp and Shield Assembly.
- | (12) Set the WOW Box Switches to W-on-W (on-ground).

---

**12. Diversity Transponder–2 Adjustment/Tests with IFR-6000 Antenna**

SUBTASK AMM-34-50-20-071-B-701-004-B

**A. Begin adjustment/test as follows:**

(1) Install Antenna Clamp and Shield Assembly (part of Transponder Test Set IFR 6000) on lower transponder antenna (bottom of the center cabin/fuselage), in accordance with instructions in IFR 6000 Ramp Test Set Operation Manual.

- (a) Position Antenna Clamp inside the slot in the Antenna Shield Plate, aligning captive screws into the respective screw holes.
- (b) Tighten captive screws.
- (c) Cover the transponder's Antenna with Antenna Shield. Loosen thumbscrews if necessary.

**NOTE:** It may be necessary to remove the unit under test's Antenna Guard if access to the transponders Antenna is restricted.

(d) Secure Antenna Shield by tightening thumbscrews.

(2) Perform job setup, refer to [SUBTASK AMM-34-50-20-071-B-921-001-B](#).

(3) Push ECB BY SYSTEM soft key. Scroll to FLCSS using outer knob. Push inner knob to select. Scroll to the listed ECB using outer knob and highlight. Push "COLLAR" soft key. Push "CONFIRM COLLAR" soft key.

- ECB - NOSE LDG GEAR (L AFT Bus)
- ECB - L MAIN LDG GEAR (L AFT Bus)
- ECB - R MAIN LDG GEAR (L AFT Bus)

(4) Scroll to ENGINE using outer knob. Push inner knob to select. Scroll to the listed ECB using outer knob and highlight. Push "COLLAR" soft key. Push "CONFIRM COLLAR" soft key.

- ECB - L ENG FIRE EXTNGR (L FWD Bus)
- ECB - R ENG FIRE EXTNGR (R FWD Bus)

(5) Clear any "MASTER CAUTIONS" and "MASTER WARNINGS" as needed.

(6) Set both left and right PFD baro set to 29.92 (in/Hg.) on Autopilot Control Panel (ACP) by pushing BARO SET knob.

- Make sure that Baro Set on PFD annunciates "29.92 IN".

**B. Diversity Transponder-2 Setup**

(1) Use the small rotary knob on the left PFD to select XPDR page.

**NOTE:** The XPDR select page times out and switches back to the COM page after 30 seconds. Select XPDR page from time to time during this test.

(2) Push ACTIVE soft key (upper right button) on the left PFD to select D-XPDR2.

(3) Make sure that D-XPDR2 is in Standby Mode.

- 
- (4) Push CODE soft key on left PFD and enter the transponder code used for this test or 1200.
- C. Diversity Transponder-2 MODE A,C,S Test using Transponder Test Set, IFR6000 (Upper Antenna)
- (1) Power up the Transponder Test Set (IFR 6000). After tester performs Self Test, push SETUP button on the test set to bring up the SETUP-XPDR page. If necessary, continue pressing SETUP button until tester cycles to SETUP-XPDR page.
  - (2) On the Transponder Test Set (IFR 6000)'s SETUP-XPDR page, use NEXT PARAM or PREV PARAM soft keys to select each parameter, and the "arrow" DATA keys to set the values listed below.
    - ANTENNA: TOP
    - RF PORT: ANTENNA
    - ANT RANGE-TOP: 18 ft.
    - ANT HEIGHT-TOP: 7 ft.
    - ANT RANGE-BOTTOM: 18 ft.
    - ANT HEIGHT-BOTTOM: 1 ft.
    - DIR CABLE LOSS: Ignore
    - ANT CABLE: 1 ft.
    - ANT CABLE LOSS: As marked on blue cable (should be 0.1 dB)
    - ANT GAIN (dBi) - 1.03 GHz: As marked on test set antenna
    - ANT GAIN (dBi) - 1.09 GHz: As marked on test set antenna
    - UUT ADDRESS: AUTO
    - MANUAL AA: Ignore
    - DIVERSITY TEST: ON
    - PWR LIM: FAR 43
    - CHECK CAP: YES
  - (3) Push XPDR button to go to the XPDR-AUTO TEST page.
  - (4) Push CONFIG soft key to display the XPDR-CONFIG SCREEN page.
  - (5) On the XPDR-CONFIG SCREEN, scroll to GENERIC MODE S using the UP/Down DATA keys.
  - (6) With GENERIC MODE S highlighted, push RETURN soft key to confirm selection. This will also cause a return to the XPDR-AUTO TEST page.
  - (7) Set the WOW Box Switches to W-off-W (airborne).
  - (8) Push RUN TEST soft key to start AUTO TEST. The tester will sequence through separate tests, after which a "PASS" message should be displayed.

- (9) Top ERP should be between 48 to 60 dBm and MTL should be between -68 to -80 dBm to PASS.

**NOTE:** If values are obtained and any of the individual tests FAIL during AUTO TEST, press TEST LIST button on IFR 6000 and using UP/DOWN buttons scroll to the specific Failed test(s). Press SELECT TEST button, adjust IFR 6000 test set positioning anywhere within a 30 foot arc between the aircraft's right wingtip and the nose as required, and Press RUN TEST button until PASS Message is received (this may take several test set position adjustments until IFR 6000 and aircraft Transponder "Sync up"). Press STOP TEST button. Repeat until all individual FAILED tests have achieved a PASS. It is not necessary to re-run AUTO TEST. AUTO TEST is a convenience feature only.

**NOTE:** If POWER/FREQ test Fails: After pressing RUN TEST, adjust IFR-6000 test set positioning while test is running until PASS message appears (this test performs a "Live" update of the dBm values). It may be required to position the test set anywhere within a 30 foot arc between the aircraft's right wingtip and the nose. Press the STOP TEST button as soon as PASS message is displayed

- (10) Make sure the following appears on the Transponder Test Set (IFR 6000):

- "A CODE" = transponder code entered
- "C ALT" = left PFD altitude indication +/- 100 ft.
- "S CODE" = ICAO code assigned to this aircraft/tail number
- "TAIL" = tail number assigned to this aircraft
- "DF17 DETECTED" = YES (IF ADS-B OUT IS INSTALLED) / NO ( IF ADS-B OUT IS NOT INSTALLED)
- "FLT ID" = same as tail number
- "AA" = ICAO code assigned to this aircraft/tail number (8 digit number in parenthesis)
- "FS" = IN-AIR
- "VS" = IN-AIR

- (11) On MFD, press SYS along bottom of MFD. Use the small lower knob on the MFD to scroll to the SETUP page. On the SETUP page, press the SETTINGS softkey to bring up the SETTINGS page. At the bottom of the SETTINGS page, check:

- (a) The "REGISTRATION NO" number (alphanumeric) matches the "TAIL" number (alphanumeric) displayed on the IFR 6000 (above).
- (b) The "ICAO 24-BIT (OCT)" number matches the "AA" ICAO 24-bit code displayed on the IFR 6000 (above).

**NOTE:** If the aircraft's registration number and/or ICAO 24-bit (octal) number are not present on the MFD's SETTINGS page, the Aircraft Configuration File must be updated, refer to [AMM-31-40-00-051-801 – Aircraft Computer Systems - Maintenance Practices](#). Steps (14) through this step must then be repeated.

- (12) On the MFD, scroll to the SETUP tab, press the SENSOR Soft Key. Set the ADC PFD source selection from AUTO to ADC 2.
  - (13) On the IFR 6000, press the XPDR button once.
  - (14) Once XPDR – ALT ENCODER is displayed, press the SOURCE SELECT Soft Key until SOURCE - XPDR is displayed. Press the RUN TEST Soft Key.
  - (15) Make sure that an altitude reported on IFR 6000 matches L PFD altitude indication +/- 100 ft.
  - (16) On the MFD, set the ADC source back to AUTO.
  - (17) Set the WOW Box Switches to W-on-W (on-ground).
  - (18) Set D-XPDR 2 to STANDBY MODE.
- D. Diversity Transponder-2 MODE A,C,S Test using Transponder Test Set (IFR 6000) (Lower Antenna)
- (1) Remove Antenna Clamp and Shield Assembly (part of Transponder Test Set IFR 6000) from lower transponder antenna (bottom of the center cabin/fuselage).
  - (2) Install Antenna Clamp and Shield Assembly (part of Transponder Test Set IFR 6000) on upper transponder antenna (top of the center cabin/fuselage), in accordance with instructions in IFR 6000 Ramp Test Set Operation Manual.
  - (3) Pre-position the Transponder Test Set IFR 6000 antenna to point at the aircraft's lower Transponder 2 antenna (bottom of the center cabin/fuselage)
  - (4) On the Transponder Test Set (IFR 6000) SETUP-XPDR page, use NEXT PARAM or PREV PARAM softkeys to select each parameter, and the "arrow" DATA keys to set the values listed below:
    - ANTENNA: BOTTOM
    - RF PORT: ANTENNA
    - ANT RANGE-TOP: 18 ft.
    - ANT HEIGHT-TOP: 7 ft.
    - ANT RANGE-BOTTOM: 18 ft.
    - ANT HEIGHT-BOTTOM: 1 ft.
    - DIR CABLE LOSS: Ignore
    - ANT CABLE: 1 ft.
    - ANT CABLE LOSS: As marked on blue cable (should be 0.1 dB)
    - ANT GAIN (dBi) - 1.03 GHz: As marked on test set antenna
    - ANT GAIN (dBi) - 1.09 GHz: As marked on test set antenna
    - UUT ADDRESS: AUTO
    - MANUAL AA: Ignore
    - DIVERSITY TEST: ON
    - PWR LIM: FAR 43

- CHECK CAP: YES
- (5) Push XPDR button to go to the XPDR-AUTO TEST page.
- (6) Push CONFIG soft key to display the XPDR-CONFIG SCREEN page.
- (7) On the XPDR-CONFIG SCREEN, scroll to GENERIC MODE S using the UP/Down DATA keys.
- (8) With GENERIC MODE S highlighted, push RETURN soft key to confirm selection. This will also cause a return to the XPDR-AUTO TEST page.
- (9) Set the WOW Box Switches to W-off-W (airborne).
- (10) Push RUN TEST soft key to start AUTO TEST. The tester will sequence through 17 separate tests, after which a “PASS” message should be displayed.
- (11) Bottom ERP should be between 48 to 60 dBm and MTL should be between -68 to -80 dBm to PASS.

**NOTE:** If values are obtained and any of the individual tests FAIL during AUTO TEST, press TEST LIST button on IFR 6000 and using UP/DOWN buttons scroll to the specific Failed test(s). Press SELECT TEST button, adjust IFR 6000 test set positioning anywhere within a 30 foot arc between the aircraft’s right wingtip and the nose as required, and Press RUN TEST button until PASS Message is received (this may take several test set position adjustments until IFR 6000 and aircraft Transponder “Sync up”). Press STOP TEST button. Repeat until all individual FAILED tests have achieved a PASS. It is not necessary to re-run AUTO TEST. AUTO TEST is a convenience feature only.

**NOTE:** If POWER/FREQ test Fails: After pressing RUN TEST, adjust IFR-6000 test set positioning while test is running until PASS message appears (this test performs a “Live” update of the dBm values). It may be required to position the test set anywhere within a 30 foot arc between the aircraft’s right wingtip and the nose. Press the STOP TEST button as soon as PASS message is displayed

- (12) Remove Antenna Clamp and Shield Assembly from aircraft and stow in IFR 6000 ramp test set kit.
- (13) Remove Antenna Clamp and Shield Assembly and stow in ramp test kit.
- (14) Set the WOW Box Switches to W-on-W (on-ground).

### 13. **Job Close-Up**

SUBTASK AMM-34-50-20-071-B-921-002

- A. Set WOW Box switches to W-on-W
- B. Reset the collared ECB’s. Refer to AMM-20-00-03-051-801 – Prepare Anti-Ice Systems For Maintenance.
- C. Scroll to FLCS using outer knob. Press inner knob to select. Scroll to the listed ECB using outer knob and highlight. Push “RESET” Soft key. Press “CONFIRM RESET” soft key.

- 
- ECB - NOSE LDG GEAR (L AFT Bus)
  - ECB - L MAIN LDG GEAR (L AFT Bus)
  - ECB - R MAIN LDG GEAR (L AFT Bus)
- D. Scroll to ENGINE using outer knob. Press inner knob to select. Scroll to the listed ECB using outer knob and highlight. Push “RESET” Soft key. Press “CONFIRM RESET” soft key.
- ECB - L ENG FIRE EXTNGR (L FWD Bus)
  - ECB - R ENG FIRE EXTNGR (R FWD Bus)
- E. Power down the aircraft by setting the SYS BATT and START BATT switches to OFF and the BUS TIE to OPEN.
- F. Disconnect WOW Box from aircraft. Refer to AMM-20-00-04-051-801 – Weight On Wheels (WOW) Box - Connect/Disconnect.
- G. If on jacks, lower aircraft and remove jacks. Refer to [AMM-07-10-00-051-801 – Jacking - Maintenance Practices](#).
- H. If applicable, call the local control tower and tell them the transponder test is complete.
- I. Remove all tools, equipment and unwanted material from work area.
- J. Disconnect external power. Refer to [AMM-24-40-00-051-801 – External Power - Maintenance Practices](#).
- K. If all other maintenance is complete, return aircraft to service. Refer to [AMM-20-00-02-051-801 – Return To Service \(After Maintenance\)](#).

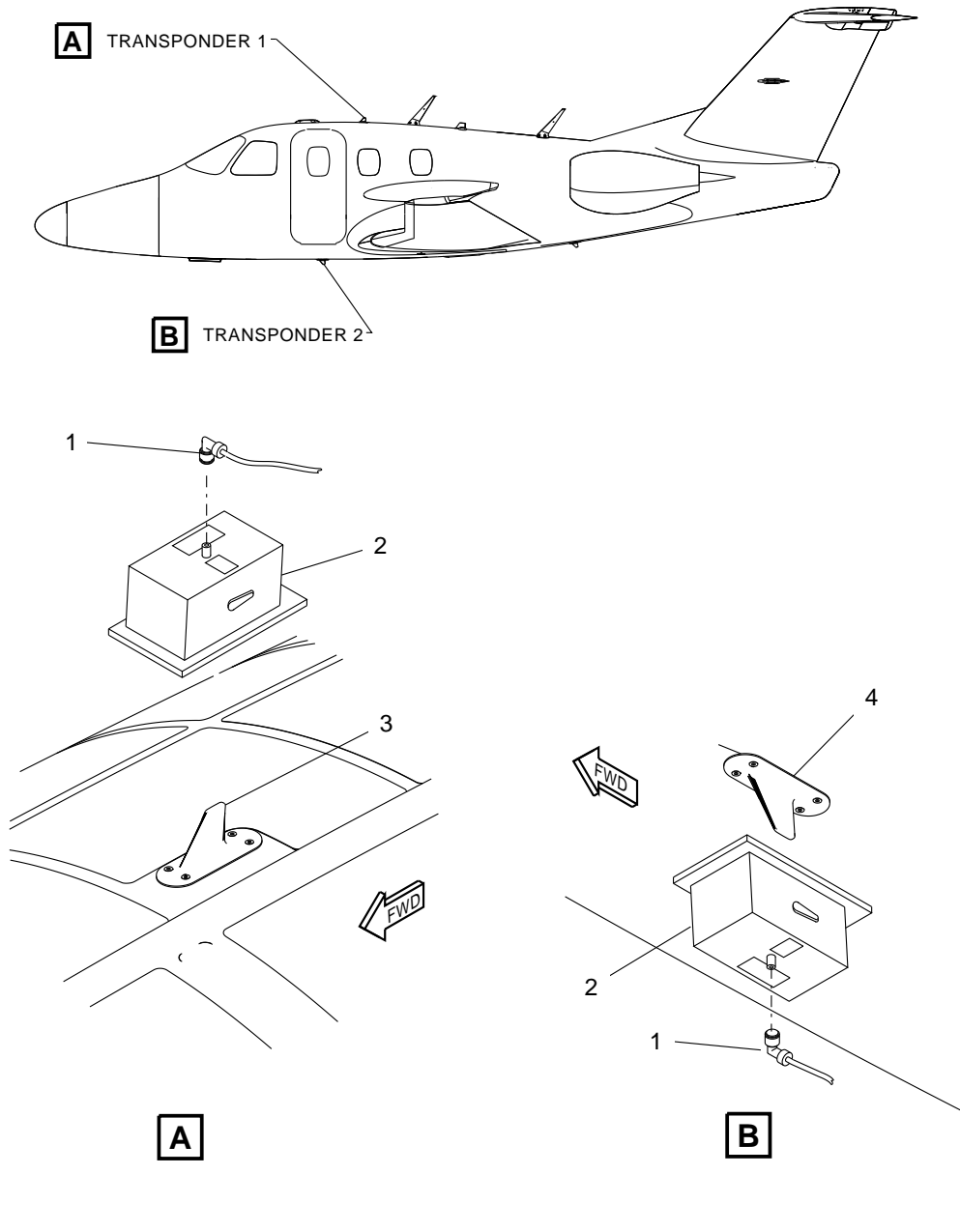

5202061A

**Transponder - Adjustment/Test  
Figure 501 (Sheet 1 of 1)**

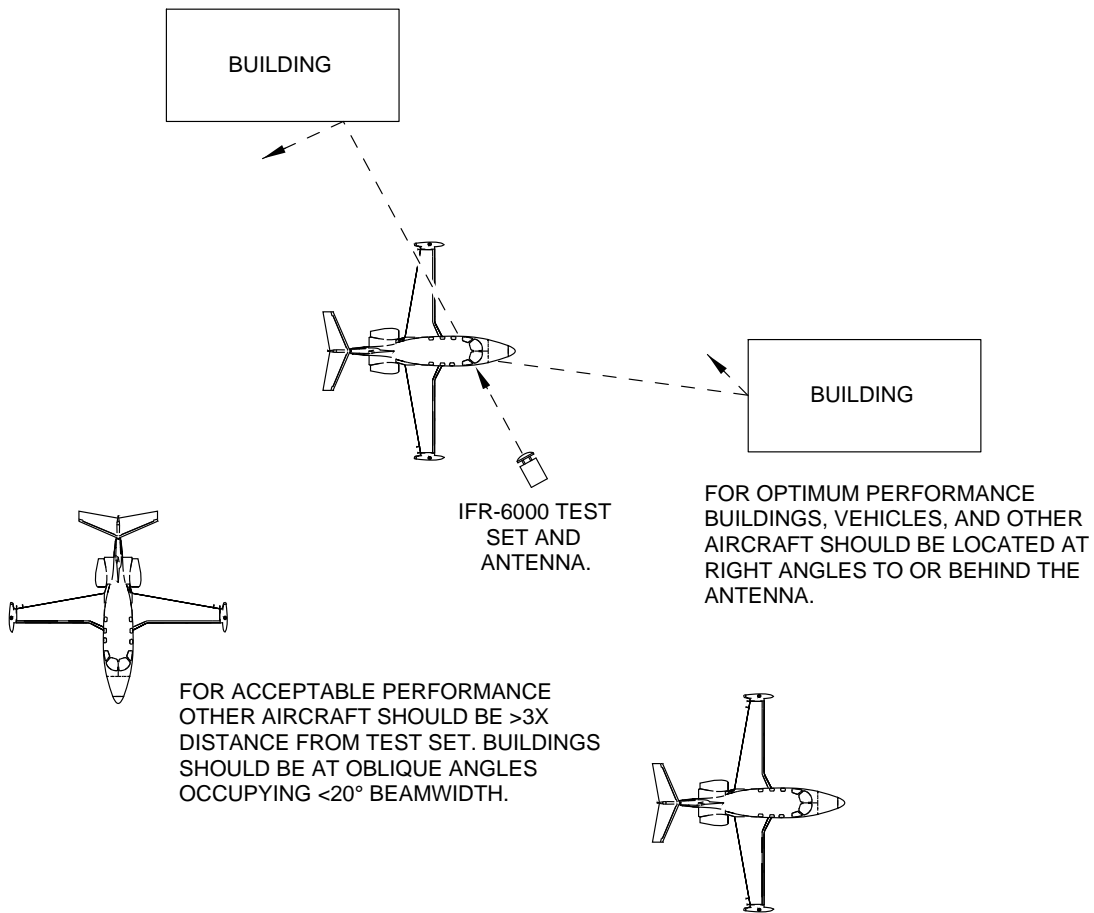
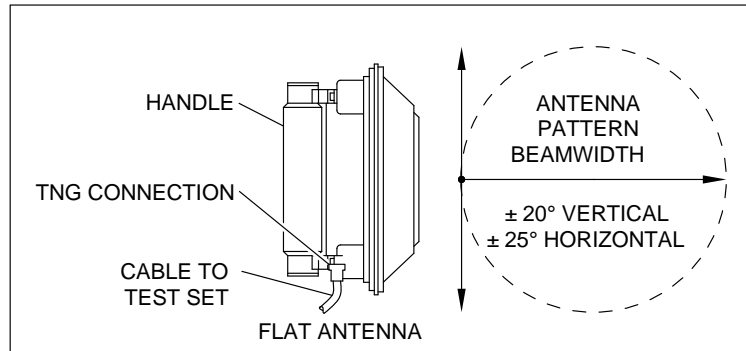

5081043A

**Transponder - Adjustment/Test  
Figure 502 (Sheet 1 of 1)**

### TRANSPONDER - ADJUSTMENT/TEST

AMM-34-50-20-071-C-801

#### 1. **General**

A. This task gives procedures to do the adjustment/test of the:

- Dual Standard (Non-Diversity) Transponder System and components or Dual Diversity Transponder System and components.

**NOTE:** An adjustment/test is only required for the transponder that is being installed. The opposite transponder, if it has not been removed, does not require an adjustment/test

B. Perform ADS-B Out System Test only if ADS-B function is enabled.

**NOTE:** Perform ADS-B Out Fail Indicator Functional Test only if the indicator is being replaced or removed and reinstalled.

Limitation: If the aircraft is equipped with Garmin GPS 400W, ADS-B OUT System Test test applies to Transponder 1 (XPDR 1) only.

- (1) Refer to [Table 501](#) for testing procedures.

**Table 501. Test Matrix**

System Test	Procedures
Dual Standard Transponder System Test	<b>Std. Transponder 1 Adjustment/Test:</b> <a href="#">SUBTASK AMM-34-50-20-071-C-701-001-A</a> or <a href="#">SUBTASK AMM-34-50-20-071-C-701-001-B</a> , and <b>Std. Transponder 2 Adjustment/Test:</b> <a href="#">SUBTASK AMM-34-50-20-071-C-701-002-A</a> or <a href="#">SUBTASK AMM-34-50-20-071-C-701-002-B</a> . <b>Transponder Cooling Adjustment/Test:</b> <a href="#">TASK AMM-34-50-24-071-801</a> .
Dual Diversity Transponder System Test	<b>Diversity Transponder 1 Adjustment/Test:</b> <a href="#">SUBTASK AMM-34-50-20-071-C-701-003-A</a> or <a href="#">SUBTASK AMM-34-50-20-071-C-701-003-B</a> , and <b>Diversity Transponder 2 Adjustment/Test:</b> <a href="#">SUBTASK AMM-34-50-20-071-C-701-004-A</a> or <a href="#">SUBTASK AMM-34-50-20-071-C-701-004-B</a> . <b>Transponder Cooling Adjustment/Test:</b> <a href="#">TASK AMM-34-50-24-071-801</a> .

System Test	Procedures
ADS-B Out System Tests	<b>ADS-B Out Test Set-Up</b> <a href="#">SUBTASK AMM-34-50-20-071-C-701-005</a> <b>ADS-B Out Functional Test:</b> <a href="#">SUBTASK AMM-34-50-20-071-C-701-006</a> <b>ADS-B Out Parameter Test:</b> <a href="#">SUBTASK AMM-34-50-20-071-C-701-007</a> <b>ADS-B Out Fail Indicator Functional Test:</b> <a href="#">SUBTASK AMM-34-50-20-071-C-701-008</a>

## 2. Equipment and Materials

**Table 502. Special Tools and Equipment**

Name and Part Number
Transponder Test Set (Aeroflex, IFR6000) or equivalent
UC-584 Universal Transponder Antenna Coupler   Dual Antenna Kit (Viavi 112349)[1]
Weight-on-Wheels (WOW) Box (EAI, 87-117390-1001) or AMC 2.4.01 (or higher).
Ground Power Unit (GPU). AllStar 450 or AllStar G.S.E. or Hobart GPU-400 or Hobart GPU-600 or Bycan PS-28100

[1] For test with UC-584 antenna coupler.

### 3. Job Set-Up with UC-584 Antenna Coupler

SUBTASK AMM-34-50-20-071-C-921-001-A

\* \* \* 0001-0104, 0113-0115, 0120, 0123-0124 POST SB 500-99-002; 0105-0112, 0116-0119, 0121-0122, 0125-0265 POST SB 500-99-005; AND 0266-0267; ALL POST MB 500-31-016, MB 500-31-018. and MB 500-34-030

Refer to [Fig. 501](#).

- A. Make aircraft safe for maintenance. Refer to [AMM-20-00-01-051-801 – Make Safe For Maintenance](#).
- B. If on jacks, refer to [AMM-07-10-00-051-801 – Jacking - Maintenance Practices](#) and [AMM-08-20-00-051-801 – Leveling](#).
- C. Connect external power. Refer to [AMM-24-40-00-051-801 – External Power - Maintenance Practices](#). Do not turn on START BATT and SYS BATT switches until prompted.
- D. Prepare Anti-ice system for maintenance. Refer to [AMM-20-00-03-051-801 – Prepare Anti-Ice Systems For Maintenance](#).
- E. Connect Antenna Coupler UC-584S to Aircraft upper Transponder Antenna as follows:  
(as applicable)

NOTE: For Transponder–1 Adjustment/Test

- (1) Place Antenna Coupler (2) over the antenna (3), guiding antenna in to the slot on the bottom of the coupler.
- (2) Lock Antenna Coupler (2) into place by pushing lever on the side of the coupler into a down and locked position.

NOTE: Coupler must be tightly pressed and locked in place for Test Set to function correctly. Coupler will lock into place when the black rubber gasket is not completely depressed against the aircraft, but the Test Set will not measure functions accurately.

CAUTION: DO NOT CONNECT COAX CABLE TO IFR-6000 ANT PORT. DAMAGE TO EQUIPMENT WILL OCCUR.

- (3) Connect long RF coaxial cable (1) between the Antenna Coupler (2) and Test Set RF I/O Connector.

CAUTION: THE RF COAXIAL CABLE CAN BE A TRIPPING HAZARD. MAKE SURE TO SECURE THE CABLE. PERSONAL INJURY AND DAMAGE TO THE ANTENNAS AND TEST EQUIPMENT COULD OCCUR.

- (4) Temporarily secure the coaxial cable to the aircraft with tape. Tape can be removed after the test is completed.
- (5) Push Antenna Coupler (2) firmly against the aircraft skin until the black rubber gasket on the rim of the coupler is completely depressed tightly against the aircraft.

- F. Connect Antenna Coupler UC-584 to Aircraft lower Transponder Antenna as follows: (as applicable)

NOTE: For Transponder-2 Adjustment/Test

- (1) Place Antenna Coupler (2) over the antenna (4) , guiding antenna in to the slot on the bottom of the coupler.
- (2) Lock Antenna Coupler (2) into place by pushing lever on the side of the coupler into a down and locked position.

NOTE: Antenna Coupler must be tightly pressed and locked in place for Test Set to function correctly. Coupler will lock into place when the black rubber gasket is not completely depressed against the aircraft, but the Test Set will not measure functions accurately.

CAUTION: DO NOT CONNECT COAX CABLE TO IFR-6000 ANT PORT. DAMAGE TO EQUIPMENT WILL OCCUR.

- (3) Connect long RF coaxial cable (1) between the Antenna Coupler and Test Set RF I/O Connector.

CAUTION: THE RF COAXIAL CABLE CAN BE A TRIPPING HAZARD. MAKE SURE TO SECURE THE CABLE. PERSONAL INJURY AND DAMAGE TO THE ANTENNAS AND TEST EQUIPMENT COULD OCCUR.

- (4) Temporarily secure the coaxial cable to the aircraft with tape. Tape can be removed after the test is completed.
- (5) Push Antenna Coupler (2) firmly against the aircraft skin until the black rubber gasket on the rim of the coupler is completely depressed tightly against the aircraft.

- G. Connect Weight On Wheels (WOW) box or Aircraft Maintenance Computer (AMC) and set switches on Box to W-On-W (on-ground). Refer to [AMM-20-00-04-051-801 – Weight On Wheels \(WOW\) Box - Connect/Disconnect](#).

---

#### 4. **Transponder-1 Adjustment/Test (Standard System) with UC-584 Antenna Coupler**

SUBTASK AMM-34-50-20-071-C-701-001-A

\* \* \* 0001-0104, 0113-0115, 0120, 0123-0124 POST SB 500-99-002; 0105-0112, 0116-0119, 0121-0122, 0125-0265 POST SB 500-99-005; AND 0266-0267; ALL POST MB 500-31-016, MB 500-31-018. and MB 500-34-030

A. Begin adjustment/test as follows:

- (1) Perform Job Set-Up with UC-584 Antenna Coupler, refer to [SUBTASK AMM-34-50-20-071-C-921-001-A](#).
- (2) Use the small rotary knob on the left PFD to select XPDR page.  
NOTE: The XPDR select page will time out and switch back to the COM page after 30 seconds. The operator will have to select XPDR page from time to time during this test.
- (3) Make sure that Transponder 1 (XPDR 1) is ACTIVE transponder in STANDBY MODE.
- (4) Scroll to FLT CTRLS using outer knob. Push inner knob to select. Scroll to the listed ECB using outer knob and highlight. Push “COLLAR” soft key. Push “CONFIRM COLLAR” soft key.
  - ECB - NOSE LDG GEAR (L AFT Bus)
  - ECB - L MAIN LDG GEAR (L AFT Bus)
  - ECB - R MAIN LDG GEAR (L AFT Bus)
- (5) Scroll to ENGINE using outer knob. Push inner knob to select. Scroll to the listed ECB using outer knob and highlight. Push “COLLAR” soft key. Push “CONFIRM COLLAR” soft key.
  - ECB - L ENG FIRE EXTNGR (L FWD Bus)
  - ECB - R ENG FIRE EXTNGR (R FWD Bus)
- (6) Clear any “MASTER CAUTIONS” and “MASTER WARNINGS” as needed.
- (7) Set both left and right PFD baro set to 29.92 (in/Hg) on Autopilot Control Panel (ACP) by pushing BARO SET knob.

B. Transponder-1 Setup

- (1) Use the small rotary knob on the left PFD to select XPDR page.  
NOTE: The XPDR select page times out and switches back to the COM page after 30 seconds. Select XPDR page from time to time during this test.
- (2) Make sure that Transponder 1 (XPDR 1) is selected as ACTIVE transponder in STANDBY MODE.
- (3) Push CODE soft key on left PFD and enter the transponder code provided by the control tower for this test. If no code was assigned, enter 1200.

C. Transponder-1 MODE A,C,S Test using Transponder Test Set, IFR6000

- (1) Power up the Transponder Test Set (IFR 6000). After tester performs Self Test, push SETUP button on the test set to bring up the SETUP-XPDR page. If necessary, continue pressing SETUP button until tester cycles to SETUP-XPDR page.
- (2) On the Transponder Test Set (IFR 6000)'s SETUP-XPDR page, use NEXT PARAM or PREV PARAM soft keys to select each parameter, and the "arrow" DATA keys to set the values listed below.
  - RF PORT: DIR W/COUPLER
  - CPL CABLE LOSS: Set to loss found on cable.
  - COUPLER LOSS: Set to loss found on coupler.
  - UUT ADDRESS: AUTO
  - MANUAL AA: Ignore
  - DIVERSITY TEST: OFF
  - CHECK CAP: YES
  - PWR LIM: FAR 43
  - RAD47: OFF.
- (3) Push XPDR button to go to the XPDR-AUTO TEST page.
- (4) Push CONFIG soft key to display the XPDR-CONFIG SCREEN page.
- (5) On the XPDR-CONFIG SCREEN, scroll to GENERIC MODE S using the UP/Down DATA keys.
- (6) With GENERIC MODE S highlighted, push RETURN soft key to confirm selection. This will also cause a return to the XPDR-AUTO TEST page.
- (7) Set the WOW test box or AMC to W-off-W (airborne).

NOTE: Transponders will transition to ALT mode automatically when airborne or simulated airborne (W-off-W).
- (8) Push RUN TEST soft key to start AUTO TEST. The tester will sequence through separate tests, after which a "PASS" message should be displayed.
- (9) Top ERP should be between 48 to 60 dBm and MTL should be between -68 to -80 dBm to PASS.
- (10) Push RUN TEST soft key on Transponder Test Set (IFR 6000) again.
- (11) Make sure the following appears on the Transponder Test Set (IFR 6000):
  - "A CODE" = transponder code entered
  - "C ALT" = left PFD altitude indication +/- 100 ft.
  - "S CODE" = ICAO code assigned to this aircraft/tail number
  - "TAIL" = tail number assigned to this aircraft
  - DF17 DETECTED = YES (IF ADS-B OUT IS INSTALLED) / NO (IF ADS-B OUT IS NOT INSTALLED)
  - "FLT ID" = same as tail number

- “AA” = ICAO code assigned to this aircraft/tail number (8 digit number in parenthesis)
  - “FS” = IN-AIR
  - “VS” = IN-AIR
- (12) On MFD, press SYS along bottom of MFD. Use the small lower knob on the MFD to scroll to the SETUP page. On the SETUP page, press the SETTINGS softkey to bring up the SETTINGS page. At the bottom of the SETTINGS page, verify:
- (a) The “REGISTRATION NO” number (alphanumeric) matches the “TAIL” number (alphanumeric) displayed on the IFR 6000 (above).
  - (b) The “ICAO 24-BIT (OCT)” number matches the “AA” ICAO 24-bit code displayed on the IFR 6000 (above).
- NOTE:** If the aircraft’s registration number and/or ICAO 24-bit (octal) number are not present on the MFD’s SETTINGS page, the Aircraft Configuration File must be updated, refer to [AMM-31-40-00-051-801 – Aircraft Computer Systems - Maintenance Practices](#). Steps (10) through this step must then be repeated.
- (13) On the MFD, scroll to the SETUP tab, press the SENSOR Soft Key. Set the ADC PFD source selection from AUTO to ADC 2.
- (14) On the IFR 6000, press the XPDR button once. Once XPDR – ALT ENCODER is displayed, press the SOURCE SELECT Soft Key until SOURCE - XPDR is displayed. Press the RUN TEST Soft Key.
- (15) Make sure that the altitude reported on IFR 6000 matches L PFD altitude indication +/- 100 ft.
- (16) On the MFD, set the ADC source back to AUTO.
- (17) Set the WOW Box Switches to W-on-W (on-ground).
- (18) Set XPDR 1 to STANDBY MODE.

---

**5. Transponder-2 Adjustment/Test (Standard System) with UC-584 Antenna Coupler**

SUBTASK AMM-34-50-20-071-C-701-002-A

\* \* \* 0001-0104, 0113-0115, 0120, 0123-0124 POST SB 500-99-002; 0105-0112, 0116-0119, 0121-0122, 0125-0265 POST SB 500-99-005; AND 0266-0267; ALL POST MB 500-31-016, MB 500-31-018. and MB 500-34-030

A. Begin adjustment/test as follows:

(1) Perform Job Set-Up with UC-584 Antenna Coupler, refer to [SUBTASK AMM-34-50-20-071-C-921-001-A](#).

(2) Use the small rotary knob on the left PFD to select XPDR page.

NOTE: The XPDR select page will time out and switch back to the COM page after 30 seconds. The operator will have to select XPDR page from time to time during this test.

(3) Push ACTIVE soft key, upper right button, on the left PFD to select XPDR 2.

(4) Make sure that Transponder 2 (XPDR 2) is in STANDBY MODE.

B. Transponder-2 Setup

(1) Push CODE soft key on right PFD and enter the transponder code provided by the control tower for this test. If no code was assigned, enter 1200.

C. Transponder-2 MODE A,C,S Test using Transponder Test Set, IFR6000

(1) Power up the Transponder Test Set (IFR 6000). After tester performs Self Test, push SETUP button on the test set to bring up the SETUP-XPDR page. If necessary, continue pressing SETUP button until tester cycles to SETUP-XPDR page.

(2) On the Transponder Test Set (IFR 6000) SETUP-XPDR page, use NEXT PARAM or PREV PARAM soft keys to select each parameter, and the "arrow" DATA keys to set the values listed below.

- RF PORT: DIR W/COUPLER
- CPL CABLE LOSS: Set to loss found on cable.
- COUPLER LOSS: Set to loss found on coupler.
- UUT ADDRESS: AUTO
- MANUAL AA: Ignore
- DIVERSITY TEST: OFF
- CHECK CAP: YES
- PWR LIM: FAR 43
- RAD47: OFF.

(3) Push XPDR button to go to the XPDR-AUTO TEST page.

(4) Push CONFIG soft key to display the XPDR-CONFIG SCREEN page.

(5) On the XPDR-CONFIG SCREEN, scroll to GENERIC MODE S using the up/down DATA keys.

- (6) With GENERIC MODE S highlighted, push RETURN soft key to confirm selection. This will also cause a return to the XPDR-AUTO TEST page.
- (7) Set the WOW Box Switches to W-off-W (airborne).
- (8) Push RUN TEST soft key to start AUTO TEST. The tester will sequence through separate tests, after which a “PASS” message should be displayed.
- (9) Bottom ERP should be between 48 to 60 dBm and MTL should be between -68 to -80 dBm to PASS.
- (10) Make sure the following appears on the Transponder Test Set (IFR 6000):
  - “A CODE” = transponder code entered
  - “C ALT” = left PFD altitude indication +/- 100 ft.
  - “S CODE” = ICAO code assigned to this aircraft/tail number
  - “TAIL” = tail number assigned to this aircraft
  - “FLT ID” = same as tail number
  - DF17 DETECTED” = YES (IF ADS-B OUT IS INSTALLED) / NO (IF ADS-B OUT IS NOT INSTALLED)
  - “AA” = ICAO code assigned to this aircraft/tail number (8 digit number in parenthesis)
  - “FS” = IN-AIR
  - “VS” = IN-AIR
- (11) On MFD, press SYS along bottom of MFD. Use the small lower knob on the MFD to scroll to the SETUP page. On the SETUP page, press the SETTINGS softkey to bring up the SETTINGS page. At the bottom of the SETTINGS page, verify:
  - (a) The “REGISTRATION NO” number (alphanumeric) matches the “TAIL” number (alphanumeric) displayed on the IFR 6000 (above).
- (12) The “ICAO 24-BIT (OCT)” number matches the “AA” ICAO 24-bit code displayed on the IFR 6000 (above).

**NOTE:** If the aircraft’s registration number and/or ICAO 24-bit (octal) number are not present on the MFD’s SETTINGS page, the Aircraft Configuration File must be updated, refer to [AMM-31-40-00-051-801 – Aircraft Computer Systems - Maintenance Practices](#).
- (13) On the MFD, scroll to the SETUP tab, press the SENSOR Soft Key. Set the ADC PFD source selection from AUTO to ADC 2.
- (14) On the IFR 6000, press the XPDR button once.
- (15) Once XPDR – ALT ENCODER is displayed, press the SOURCE SELECT Soft Key until SOURCE - XPDR is displayed. Press the RUN TEST Soft Key.
- (16) Make sure that an altitude reported on IFR 6000 matches L PFD altitude indication +/- 100 ft.
- (17) On the MFD, set the ADC source back to AUTO.
- (18) Set the WOW Box Switches to W-on-W (on-ground).

- (19) Set XPDR 2 to STANDBY MODE.

## **6. Diversity Transponder–1 Adjustment/Tests with UC-584 Antenna Coupler**

SUBTASK AMM-34-50-20-071-C-701-003-A

\* \* \* 0001-0104, 0113-0115, 0120, 0123-0124 POST SB 500-99-002; 0105-0112, 0116-0119, 0121-0122, 0125-0265 POST SB 500-99-005; AND 0266-0267; ALL POST MB 500-31-016, MB 500-31-018. and MB 500-34-030

### **A. Begin adjustment/test as follows:**

- (1) Install Antenna Clamp and Shield Assembly (part of Transponder Test Set IFR 6000) on lower transponder antenna (bottom of the center cabin/fuselage), in accordance with instructions in IFR 6000 Ramp Test Set Operation Manual.
  - (a) Position Antenna Clamp inside the slot in the Antenna Shield Plate, aligning captive screws into the respective screw holes.
  - (b) Tighten captive screws.
  - (c) Cover the transponder's Antenna with Antenna Shield. Loosen thumbscrews if necessary.

NOTE: It may be necessary to remove the unit under test's Antenna Guard if access to the transponders Antenna is restricted.
  - (d) Secure Antenna Shield by tightening thumbscrews.
- (2) Perform Job Set-Up with UC-584 Antenna Coupler, refer to [SUBTASK AMM-34-50-20-071-C-921-001-A](#).
- (3) Push ECB BY SYSTEM soft key. Scroll to FLCS using outer knob. Push inner knob to select. Scroll to the listed ECB using outer knob and highlight. Push "COLLAR" soft key. Push "CONFIRM COLLAR" soft key.
  - ECB - NOSE LDG GEAR (L AFT Bus)
  - ECB - L MAIN LDG GEAR (L AFT Bus)
  - ECB - R MAIN LDG GEAR (L AFT Bus)
- (4) Scroll to ENGINE using outer knob. Push inner knob to select. Scroll to the listed ECB using outer knob and highlight. Push "COLLAR" soft key. Push "CONFIRM COLLAR" soft key.
  - ECB - L ENG FIRE EXTNGR (L FWD Bus)
  - ECB - R ENG FIRE EXTNGR (R FWD Bus)
- (5) Clear any "MASTER CAUTIONS" and "MASTER WARNINGS" as needed.
- (6) Set both left and right PFD baro set to 29.92 (in/Hg.) on Autopilot Control Panel (ACP) by pushing BARO SET knob.
  - Make sure Baro Set on PFD annunciates "29.92 IN".

### **B. Diversity Transponder-1 Setup**

- (1) Use the small rotary knob on the left PFD to select XPDR page.  
NOTE: The XPDR select page times out and switches back to the COM page after 30 seconds. Select XPDR page from time to time during this test.
  - (2) Push ACTIVE soft key (upper right button) on the left PFD to select D-XPDR1.
  - (3) Make sure that the selected transponder is in Standby Mode.
  - (4) Push CODE soft key on left PFD and enter the transponder code used for this test or 1200.
- C. Diversity Transponder-1 MODE A,C,S Test using Transponder Test Set, IFR6000 (Upper Antenna)
- (1) Power up the Transponder Test Set (IFR 6000). After tester performs Self Test, push SETUP button on the test set to bring up the SETUP-XPDR page. If necessary, continue pressing SETUP button until tester cycles to SETUP-XPDR page.
  - (2) On the Transponder Test Set (IFR 6000)'s SETUP-XPDR page, use NEXT PARAM or PREV PARAM soft keys to select each parameter, and the "arrow" DATA keys to set the values listed below.
    - RF PORT: DIR W/COUPLER
    - CPL CABLE LOSS: Set to loss found on cable.
    - COUPLER LOSS: Set to loss found on coupler.
    - UUT ADDRESS: AUTO
    - MANUAL AA: Ignore
    - DIVERSITY TEST: ON
    - CHECK CAP: YES
    - PWR LIM: FAR 43
    - RAD47: OFF.
  - (3) Push XPDR button to go to the XPDR-AUTO TEST page.
  - (4) Push CONFIG soft key to display the XPDR-CONFIG SCREEN page.
  - (5) On the XPDR-CONFIG SCREEN, scroll to GENERIC MODE S using the UP/Down DATA keys.
  - (6) With GENERIC MODE S highlighted, push RETURN soft key to confirm selection. This will also cause a return to the XPDR-AUTO TEST page.
  - (7) Set the WOW Box Switches to W-off-W (airborne).
  - (8) Push RUN TEST soft key to start AUTO TEST. The tester will sequence through separate tests, after which a "PASS" message should be displayed.
  - (9) Top ERP should be between 48 to 60 dBm and MTL should be between -68 to -80 dBm to PASS.
  - (10) Make sure the following appears on the Transponder Test Set (IFR 6000):
    - "A CODE" = transponder code entered

- “C ALT” = left PFD altitude indication +/- 100 ft.
  - “S CODE” = ICAO code assigned to this aircraft/tail number
  - “TAIL” = tail number assigned to this aircraft
  - “FLT ID” = same as tail number
  - DF17 DETECTED” = YES (IF ADS-B OUT IS INSTALLED) / NO (IF ADS-B OUT IS NOT INSTALLED)
  - “AA” = ICAO code assigned to this aircraft/tail number (8 digit number in parenthesis)
  - “FS” = IN-AIR
  - “VS” = IN-AIR
- (11) On MFD, press SYS along bottom of MFD. Use the small lower knob on the MFD to scroll to the SETUP page. On the SETUP page, press the SETTINGS soft key to bring up the SETTINGS page. At the bottom of the SETTINGS page, verify:
- (a) The “REGISTRATION NO” number (alphanumeric) matches the “TAIL” number (alphanumeric) displayed on the IFR 6000 (above).
  - (b) The “ICAO 24-BIT (OCT)” number matches the “AA” ICAO 24-bit code displayed on the IFR 6000 (above).
- NOTE:** If the aircraft’s registration number and/or ICAO 24-bit (octal) number are not present on the MFD’s SETTINGS page, the Aircraft Configuration File must be updated, refer to [AMM-31-40-00-051-801 – Aircraft Computer Systems - Maintenance Practices](#). Steps (10) through this step must then be repeated.
- (12) On the MFD, scroll to the SETUP tab, press the SENSOR Soft Key. Set the ADC PFD source selection from AUTO to ADC 2.
- (13) On the IFR 6000, press the XPDR button once.
- (14) Once XPDR – ALT ENCODER is displayed, press the SOURCE SELECT Soft Key until SOURCE - XPDR is displayed. Press the RUN TEST Soft Key.
- (15) Make sure that an altitude reported on IFR 6000 matches L PFD altitude indication +/- 100 ft.
- (16) On the MFD, set the ADC source back to AUTO.
- (17) Set the WOW Box Switches to W-on-W (on-ground).
- (18) Set D-XPDR 1 to STANDBY MODE.
- D. Diversity Transponder-1 MODE A,C,S Test using Transponder Test Set (IFR 6000) (Lower Antenna)
- (1) Remove Antenna Clamp and Shield Assembly (part of Transponder Test Set IFR 6000) from lower transponder antenna (bottom center cabin/fuselage).
  - (2) Remove CU-584S Antenna Coupler from upper transponder antenna.

- (3) Install Antenna Clamp and Shield Assembly (part of Transponder Test Set IFR 6000) on upper transponder antenna (top of the center cabin/fuselage), in accordance with instructions in IFR 6000 Ramp Test Set Operation Manual.
- (4) Install CU-584 Antenna Coupler on lower transponder antenna. Refer to Job Set-Up with UC-584 Antenna Couplers [SUBTASK AMM-34-50-20-071-C-921-001-A](#).
- (5) Push XPDR button to go to the XPDR-AUTO TEST page.
- (6) Push CONFIG soft key to display the XPDR-CONFIG SCREEN page.
- (7) On the XPDR-CONFIG SCREEN, scroll to GENERIC MODE S using the UP/Down DATA keys.
- (8) With GENERIC MODE S highlighted, push RETURN soft key to confirm selection. This will also cause a return to the XPDR-AUTO TEST page.
- (9) Set the WOW Box Switches to W-off-W (airborne).
- (10) Push RUN TEST soft key to start AUTO TEST. The tester will sequence through separate tests, after which a "PASS" message should be displayed.
- (11) ERP should be between 48 to 60 dBm and MTL should be between -68 to -80 dBm to PASS.
- (12) Remove Antenna Clamp and Shield Assembly.
- (13) Remove CU-584 Antenna Coupler from lower transponder antenna.
- (14) Set the WOW Box Switches to W-on-W (on-ground).

## 7. Diversity Transponder–2 Adjustment/Tests with UC-584 Antenna Coupler

SUBTASK AMM-34-50-20-071-C-701-004-A

\* \* \* 0001-0104, 0113-0115, 0120, 0123-0124 POST SB 500-99-002; 0105-0112, 0116-0119, 0121-0122, 0125-0265 POST SB 500-99-005; AND 0266-0267; ALL POST MB 500-31-016, MB 500-31-018. and MB 500-34-030

### A. Begin adjustment/test as follows:

- (1) Install Antenna Clamp and Shield Assembly (part of Transponder Test Set IFR 6000) on lower transponder antenna (bottom of the center cabin/fuselage), in accordance with instructions in IFR 6000 Ramp Test Set Operation Manual.
  - (a) Position Antenna Clamp inside the slot in the Antenna Shield Plate, aligning captive screws into the respective screw holes.
  - (b) Tighten captive screws.
  - (c) Cover the transponder's Antenna with Antenna Shield. Loosen thumbscrews if necessary.

NOTE: It may be necessary to remove the unit under test's Antenna Guard if access to the transponders Antenna is restricted.
  - (d) Secure Antenna Shield by tightening thumbscrews.
- (2) Perform Job Set-Up with UC-584 Antenna Coupler, refer to [SUBTASK AMM-34-50-20-071-C-921-001-A](#).
- (3) Push ECB BY SYSTEM soft key. Scroll to FLCS using outer knob. Push inner knob to select. Scroll to the listed ECB using outer knob and highlight. Push "COLLAR" soft key. Push "CONFIRM COLLAR" soft key.
  - ECB - NOSE LDG GEAR (L AFT Bus)
  - ECB - L MAIN LDG GEAR (L AFT Bus)
  - ECB - R MAIN LDG GEAR (L AFT Bus)
- (4) Scroll to ENGINE using outer knob. Push inner knob to select. Scroll to the listed ECB using outer knob and highlight. Push "COLLAR" soft key. Push "CONFIRM COLLAR" soft key.
  - ECB - L ENG FIRE EXTNGR (L FWD Bus)
  - ECB - R ENG FIRE EXTNGR (R FWD Bus)
- (5) Clear any "MASTER CAUTIONS" and "MASTER WARNINGS" as needed.
- (6) Set both left and right PFD baro set to 29.92 (in/Hg.) on Autopilot Control Panel (ACP) by pushing BARO SET knob.
  - Make sure Baro Set on PFD annunciates "29.92 IN".

### B. Diversity Transponder-2 Setup

- (1) Use the small rotary knob on the left PFD to select XPDR page.

NOTE: The XPDR select page times out and switches back to the COM page after 30 seconds. Select XPDR page from time to time during this test.

- (2) Push ACTIVE soft key (upper right button) on the left PFD to select D-XPDR2.
  - (3) Make sure that D-XPDR2 is in Standby Mode.
  - (4) Push CODE soft key on left PFD and enter the transponder code used for this test or 1200.
- C. Diversity Transponder-2 MODE A,C,S Test using Transponder Test Set, IFR6000 (Upper Antenna)
- (1) Power up the Transponder Test Set (IFR 6000). After tester performs Self Test, push SETUP button on the test set to bring up the SETUP-XPDR page. If necessary, continue pressing SETUP button until tester cycles to SETUP-XPDR page.
  - (2) On the Transponder Test Set (IFR 6000)'s SETUP-XPDR page, use NEXT PARAM or PREV PARAM soft keys to select each parameter, and the "arrow" DATA keys to set the values listed below.
    - RF PORT: DIR W/COUPLER
    - CPL CABLE LOSS: Set to loss found on cable.
    - COUPLER LOSS: Set to loss found on coupler.
    - UUT ADDRESS: AUTO
    - MANUAL AA: Ignore
    - DIVERSITY TEST: ON
    - CHECK CAP: YES
    - PWR LIM: FAR 43
    - RAD47: OFF.
  - (3) Push XPDR button to go to the XPDR-AUTO TEST page.
  - (4) Push CONFIG soft key to display the XPDR-CONFIG SCREEN page.
  - (5) On the XPDR-CONFIG SCREEN, scroll to GENERIC MODE S using the UP/Down DATA keys.
  - (6) With GENERIC MODE S highlighted, push RETURN soft key to confirm selection. This will also cause a return to the XPDR-AUTO TEST page.
  - (7) Set the WOW Box Switches to W-off-W (airborne).
  - (8) Push RUN TEST soft key to start AUTO TEST. The tester will sequence through separate tests, after which a "PASS" message should be displayed.
  - (9) Top ERP should be between 48 to 60 dBm and MTL should be between -68 to -80 dBm to PASS.
  - (10) Make sure the following appears on the Transponder Test Set (IFR 6000):
    - "A CODE" = transponder code entered
    - "C ALT" = left PFD altitude indication +/- 100 ft.
    - "S CODE" = ICAO code assigned to this aircraft/tail number
    - "TAIL" = tail number assigned to this aircraft

- “DF17 DETECTED” = YES (IF ADS-B OUT IS INSTALLED) / NO (IF ADS-B OUT IS NOT INSTALLED)
  - “FLT ID” = same as tail number
  - “AA” = ICAO code assigned to this aircraft/tail number (8 digit number in parenthesis)
  - “FS” = IN-AIR
  - “VS” = IN-AIR
- (11) On MFD, press SYS along bottom of MFD. Use the small lower knob on the MFD to scroll to the SETUP page. On the SETUP page, press the SETTINGS softkey to bring up the SETTINGS page. At the bottom of the SETTINGS page, verify:
- (a) The “REGISTRATION NO” number (alphanumeric) matches the “TAIL” number (alphanumeric) displayed on the IFR 6000 (above).
  - (b) The “ICAO 24-BIT (OCT)” number matches the “AA” ICAO 24-bit code displayed on the IFR 6000 (above).
- NOTE:** If the aircraft’s registration number and/or ICAO 24-bit (octal) number are not present on the MFD’s SETTINGS page, the Aircraft Configuration File must be updated, refer to [AMM-31-40-00-051-801 – Aircraft Computer Systems - Maintenance Practices](#). Steps (10) through this step must then be repeated.
- (12) On the MFD, scroll to the SETUP tab, press the SENSOR Soft Key. Set the ADC PFD source selection from AUTO to ADC 2.
- (13) On the IFR 6000, press the XPDR button once.
- (14) Once XPDR – ALT ENCODER is displayed, press the SOURCE SELECT Soft Key until SOURCE - XPDR is displayed. Press the RUN TEST Soft Key.
- (15) Make sure that an altitude reported on IFR 6000 matches L PFD altitude indication +/- 100 ft.
- (16) On the MFD, set the ADC source back to AUTO.
- (17) Set the WOW Box Switches to W-on-W (on-ground).
- (18) Set D-XPDR 2 to STANDBY MODE.
- D. Diversity Transponder-2 MODE A,C,S Test using Transponder Test Set (IFR 6000) (Lower Antenna)
- (1) Remove Antenna Clamp and Shield Assembly (part of Transponder Test Set IFR 6000) from lower transponder antenna (bottom center cabin/fuselage).
  - (2) Remove CU-584S Antenna Coupler from upper transponder antenna.
  - (3) Install Antenna Clamp and Shield Assembly (part of Transponder Test Set IFR 6000) on upper transponder antenna (top of the center cabin/fuselage), in accordance with instructions in IFR 6000 Ramp Test Set Operation Manual.
  - (4) Install CU-584 Antenna Coupler on lower transponder antenna. Refer to Job Set-Up with UC-584 Antenna Couplers [SUBTASK AMM-34-50-20-071-C-921-001-A](#).
  - (5) Remove Antenna Clamp and Shield Assembly (part of Transponder Test Set IFR 6000) from lower transponder antenna (bottom of the center cabin/fuselage).

- (6) Install Antenna Clamp and Shield Assembly (part of Transponder Test Set IFR 6000) on upper transponder antenna (top of the center cabin/fuselage), in accordance with instructions in IFR 6000 Ramp Test Set Operation Manual.
- (7) Pre-position the Transponder Test Set IFR 6000 antenna to point at the aircraft's lower Transponder 2 antenna (bottom of the center cabin/fuselage).
- (8) On the Transponder Test Set (IFR 6000) SETUP-XPDR page, use NEXT PARAM or PREV PARAM softkeys to select each parameter, and the "arrow" DATA keys to set the values listed below:
  - RF PORT: DIR W/COUPLER
  - DIR CABLE LOSS: Ignore
  - CPL CABLE LOSS: Set to loss found on cable.
  - COUPLER LOSS: Set to loss found on coupler.
  - UUT ADDRESS: AUTO
  - MANUAL AA: Ignore
  - DIVERSITY TEST: ON
  - PWR LIM: FAR 43
  - CHECK CAP: YES
- (9) Push XPDR button to go to the XPDR-AUTO TEST page.
- (10) Push CONFIG soft key to display the XPDR-CONFIG SCREEN page.
- (11) On the XPDR-CONFIG SCREEN, scroll to GENERIC MODE S using the UP/Down DATA keys.
- (12) With GENERIC MODE S highlighted, push RETURN soft key to confirm selection. This will also cause a return to the XPDR-AUTO TEST page.
- (13) Set the WOW Box Switches to W-off-W (airborne).
- (14) Push RUN TEST soft key to start AUTO TEST. The tester will sequence through separate tests, after which a "PASS" message should be displayed.
- (15) Bottom ERP should be between 48 to 60 dBm and MTL should be between -68 to -80 dBm to PASS.
- (16) Remove Antenna Clamp and Shield Assembly from aircraft and stow in IFR 6000 ramp test set kit.
- (17) Remove CU-584 Antenna Coupler from lower transponder antenna.
- (18) Set the WOW Box Switches to W-on-W (on-ground).
- (19) Test complete, go to Job Close-up (

---

## 8. Job Set-Up with IFR-6000 Test Set Antenna

SUBTASK AMM-34-50-20-071-C-921-001

\* \* \* 0001-0104, 0113-0115, 0120, 0123-0124 POST SB 500-99-002; 0105-0112, 0116-0119, 0121-0122, 0125-0265 POST SB 500-99-005; AND 0266-0267; ALL POST MB 500-31-016, MB 500-31-018. and MB 500-34-030

- A. Make aircraft safe for maintenance. Refer to [AMM-20-00-01-051-801 – Make Safe For Maintenance](#).
- B. If on jacks, refer to [AMM-07-10-00-051-801 – Jacking - Maintenance Practices](#) and [AMM-08-20-00-051-801 – Leveling](#).
- C. Connect external power. Refer to [AMM-24-40-00-051-801 – External Power - Maintenance Practices](#). Do not turn on START BATT and SYS BATT switches until prompted.
- D. Prepare Anti-ice system for maintenance. Refer to [AMM-20-00-03-051-801 – Prepare Anti-Ice Systems For Maintenance](#) .
- E. Take proper safety precautions to protect personnel. Position aircraft such that multi-path RF reflections between the IFR-6000 test set, the aircraft's antennas, and surrounding objects are minimized. The area on the left side of the aircraft should not be up against a metal wall or another aircraft. If necessary, position the aircraft outside, away from metal buildings or other aircraft. Refer to [Fig. 501](#).

**CAUTION:** FAILURE TO COMPLY WITH THIS STEP AND CONTINUING WITH THIS PROCEDURE COULD IMPACT LOCAL AIRPORT TOWER OPERATIONS.

- F. If applicable, contact local airport tower to inform them a transponder test is being run at your location (inside or outside). Request appropriate squawk and allotted time to run test.

**NOTE:** If local airport tower is not informed, use code 1200.

- G. Attach test set antenna to Transponder Test Set using 1 foot long test set cable (blue cable, supplied if IFR6000 is used), connected to ANT port on tester.
- H. During testing, place the Transponder Test Set antenna approximately two feet to four feet forward and in line with right wing tip tank. May require periodic repositioning between two and four feet.
- I. Connect Weight On Wheels (WOW) box or Aircraft Maintenance Computer (AMC) and set switches on Box to W-On-W (on-ground). Refer to [AMM-20-00-04-051-801 – Weight On Wheels \(WOW\) Box - Connect/Disconnect](#).

---

**9. Transponder-1 Adjustment/Test (Standard System) with IFR-6000 Test Set Antenna**

SUBTASK AMM-34-50-20-071-C-701-001-B

\* \* \* 0001-0104, 0113-0115, 0120, 0123-0124 POST SB 500-99-002; 0105-0112, 0116-0119, 0121-0122, 0125-0265 POST SB 500-99-005; AND 0266-0267

A. Begin adjustment/test as follows:

- (1) Perform job setup, refer to [SUBTASK AMM-34-50-20-071-C-921-001](#).
- (2) Re-align the Transponder Test Set, IFR6000 antenna to point at the aircraft's Transponder-1 antenna (top of the center cabin/fuselage).
- (3) Use the small rotary knob on the left PFD to select XPDR page. NOTE: The XPDR select page will time out and switch back to the COM page after 30 seconds. The operator will have to select XPDR page from time to time during this test.
- (4) Make sure that Transponder 1 (XPDR 1) is ACTIVE transponder in STANDBY MODE.
- (5) Scroll to FLT CTRLS using outer knob. Push inner knob to select. Scroll to the listed ECB using outer knob and highlight. Push "COLLAR" soft key. Push "CONFIRM COLLAR" soft key.
  - ECB - NOSE LDG GEAR (L AFT Bus)
  - ECB - L MAIN LDG GEAR (L AFT Bus)
  - ECB - R MAIN LDG GEAR (L AFT Bus)
- (6) Scroll to ENGINE using outer knob. Push inner knob to select. Scroll to the listed ECB using outer knob and highlight. Push "COLLAR" soft key. Push "CONFIRM COLLAR" soft key.
  - ECB - L ENG FIRE EXTNGR (L FWD Bus)
  - ECB - R ENG FIRE EXTNGR (R FWD Bus)
- (7) Clear any "MASTER CAUTIONS" and "MASTER WARNINGS" as needed.
- (8) Set both left and right PFD baro set to 29.92 (in/Hg) on Autopilot Control Panel (ACP) by pushing BARO SET knob.

B. Transponder-1 Setup

- (1) Use the small rotary knob on the left PFD to select XPDR page.  
NOTE: The XPDR select page times out and switches back to the COM page after 30 seconds. Select XPDR page from time to time during this test.
- (2) Make sure that Transponder 1 (XPDR 1) is selected as ACTIVE transponder in STANDBY MODE.
- (3) Push CODE soft key on left PFD and enter the transponder code provided by the control tower for this test. If no code was assigned, enter 1200.

C. Transponder-1 MODE A,C,S Test using Transponder Test Set, IFR6000

- (1) Power up the Transponder Test Set (IFR 6000). After tester performs Self Test, push SETUP button on the test set to bring up the SETUP-XPDR page. If necessary, continue pressing SETUP button until tester cycles to SETUP-XPDR page.
- (2) On the Transponder Test Set (IFR 6000)'s SETUP-XPDR page, use NEXT PARAM or PREV PARAM soft keys to select each parameter, and the "arrow" DATA keys to set the values listed below.
  - ANTENNA: TOP
  - RF PORT: ANTENNA
  - ANT RANGE-TOP: 18 ft.
  - ANT HEIGHT-TOP: 7 ft.
  - ANT RANGE-BOTTOM: 18 ft.
  - ANT HEIGHT-BOTTOM: 1 ft.
  - DIR CABLE LOSS: Ignore
  - ANT CABLE: 1 ft.
  - ANT CABLE LOSS: As marked on blue cable (should be 0.1 dB)
  - ANT GAIN (dBi) - 1.03 GHz: As marked on test set antenna
  - ANT GAIN (dBi) - 1.09 GHz: As marked on test set antenna
  - UUT ADDRESS: AUTO
  - MANUAL AA: Ignore
  - DIVERSITY TEST: OFF
  - PWR LIM: FAR 43
  - CHECK CAP: YES
- (3) Push XPDR button to go to the XPDR-AUTO TEST page.
- (4) Push CONFIG soft key to display the XPDR-CONFIG SCREEN page.
- (5) On the XPDR-CONFIG SCREEN, scroll to GENERIC MODE S using the UP/Down DATA keys.
- (6) With GENERIC MODE S highlighted, push RETURN soft key to confirm selection. This will also cause a return to the XPDR-AUTO TEST page.
- (7) Set the WOW test box or AMC to W-off-W (airborne).

NOTE: Transponders will transition to ALT mode automatically when airborne or simulated airborne (W-off-W).
- (8) Push RUN TEST soft key to start AUTO TEST. The tester will sequence through separate tests, after which a "PASS" message should be displayed.

- (9) Top ERP should be between 48 to 60 dBm and MTL should be between -68 to -80 dBm to PASS.

**NOTE:** If values are obtained and any of the individual tests FAIL during AUTO TEST, press TEST LIST button on IFR 6000 and using UP/DOWN buttons scroll to the specific Failed test(s). Press SELECT TEST button, adjust IFR 6000 test set positioning anywhere within a 30 foot arc between the aircraft's right wingtip and the nose as required, and Press RUN TEST button until PASS Message is received (this may take several test set position adjustments until IFR 6000 and aircraft Transponder "Sync up"). Press STOP TEST button. Repeat until all individual FAILED tests have achieved a PASS. It is not necessary to re-run AUTO TEST. AUTO TEST is a convenience feature only.

**NOTE:** If POWER/FREQ test Fails: After pressing RUN TEST, adjust IFR-6000 test set positioning while test is running until PASS message appears (this test performs a "Live" update of the dBm values). It may be required to position the test set anywhere within a 30 foot arc between the aircraft's right wingtip and the nose. Press the STOP TEST button as soon as PASS message is displayed

- (10) Push RUN TEST soft key on Transponder Test Set (IFR 6000) again.
- (11) Make sure the following appears on the Transponder Test Set (IFR 6000):
- "A CODE" = transponder code entered
  - "C ALT" = left PFD altitude indication +/- 100 ft.
  - "S CODE" = ICAO code assigned to this aircraft/tail number
  - "TAIL" = tail number assigned to this aircraft
  - DF17 DETECTED = YES (IF ADS-B OUT IS INSTALLED) / NO (IF ADS-B OUT IS NOT INSTALLED)
  - "FLT ID" = same as tail number
  - "AA" = ICAO code assigned to this aircraft/tail number (8 digit number in parenthesis)
  - "FS" = IN-AIR
  - "VS" = IN-AIR
- (12) On MFD, press SYS along bottom of MFD. Use the small lower knob on the MFD to scroll to the SETUP page. On the SETUP page, press the SETTINGS softkey to bring up the SETTINGS page. At the bottom of the SETTINGS page, verify:
- (a) The "REGISTRATION NO" number (alphanumeric) matches the "TAIL" number (alphanumeric) displayed on the IFR 6000 (above).

- 
- (b) The “ICAO 24-BIT (OCT)” number matches the “AA” ICAO 24-bit code displayed on the IFR 6000 (above).

**NOTE:** If the aircraft’s registration number and/or ICAO 24-bit (octal) number are not present on the MFD’s SETTINGS page, the Aircraft Configuration File must be updated, refer to [AMM-31-40-00-051-801 – Aircraft Computer Systems - Maintenance Practices](#). Steps (10) through this step must then be repeated.

- (13) On the MFD, scroll to the SETUP tab, press the SENSOR Soft Key. Set the ADC PFD source selection from AUTO to ADC 2.
- (14) On the IFR 6000, press the XPDR button once. Once XPDR - ALT ENCODER is displayed, press the SOURCE SELECT Soft Key until SOURCE - XPDR is displayed. Press the RUN TEST Soft Key.
- (15) Make sure that the altitude reported on IFR 6000 matches L PFD altitude indication +/- 100 ft.
- (16) On the MFD, set the ADC source back to AUTO.
- (17) Set the WOW Box Switches to W-on-W (on-ground).
- (18) Set XPDR 1 to STANDBY MODE.

---

**10. Transponder-2 Adjustment/Test (Standard System) with IFR-6000 Test Set Antenna**

SUBTASK AMM-34-50-20-071-C-701-002-B

\* \* \* 0001-0104, 0113-0115, 0120, 0123-0124 POST SB 500-99-002; 0105-0112, 0116-0119, 0121-0122, 0125-0265 POST SB 500-99-005; AND 0266-0267

A. Begin adjustment/test as follows:

- (1) Perform job setup, refer to [SUBTASK AMM-34-50-20-071-C-921-001](#).
- (2) Re-align the Transponder Test Set, IFR6000 antenna to point at the aircraft's lower Transponder-2 antenna (bottom of the center cabin/fuselage).
- (3) Use the small rotary knob on the left PFD to select XPDR page.

NOTE: The XPDR select page will time out and switch back to the COM page after 30 seconds. The operator will have to select XPDR page from time to time during this test.

- (4) Push ACTIVE soft key, upper right button, on the left PFD to select XPDR 2.
- (5) Make sure that Transponder 2 (XPDR 2) is in STANDBY MODE.

B. Transponder-2 Setup

- (1) Push CODE soft key on right PFD and enter the transponder code provided by the control tower for this test. If no code was assigned, enter 1200.

C. Transponder-2 MODE A,C,S Test using Transponder Test Set, IFR6000

- (1) Power up the Transponder Test Set (IFR 6000). After tester performs Self Test, push SETUP button on the test set to bring up the SETUP-XPDR page. If necessary, continue pressing SETUP button until tester cycles to SETUP-XPDR page.
- (2) On the Transponder Test Set (IFR 6000) SETUP-XPDR page, use NEXT PARAM or PREV PARAM soft keys to select each parameter, and the "arrow" DATA keys to set the values listed below.

- ANTENNA: BOTTOM
- RF PORT: ANTENNA
- ANT RANGE-TOP: 18 ft.
- ANT HEIGHT-BOTTOM: 7 ft.
- ANT RANGE-BOTTOM: 18 ft.
- ANT HEIGHT-TOP: 1 ft.
- DIR CABLE LOSS: Ignore
- ANT CABLE: 1 ft.
- ANT CABLE LOSS: As marked on blue cable (should be 0.1 dB)
- ANT GAIN (dBi) - 1.03 GHz: As marked on test set antenna
- ANT GAIN (dBi) - 1.09 GHz: As marked on test set antenna
- UUT ADDRESS: AUTO

- MANUAL AA: Ignore
  - DIVERSITY TEST: OFF
  - PWR LIM: FAR 43
  - CHECK CAP: YES
- (3) Push XPDR button to go to the XPDR-AUTO TEST page.
  - (4) Push CONFIG soft key to display the XPDR-CONFIG SCREEN page.
  - (5) On the XPDR-CONFIG SCREEN, scroll to GENERIC MODE S using the up/down DATA keys.
  - (6) With GENERIC MODE S highlighted, push RETURN soft key to confirm selection. This will also cause a return to the XPDR-AUTO TEST page.
  - (7) Set the WOW Box Switches to W-off-W (airborne).
  - (8) Push RUN TEST soft key to start AUTO TEST. The tester will sequence through separate tests, after which a “PASS” message should be displayed.
  - (9) Bottom ERP should be between 48 to 60 dBm and MTL should be between -68 to -80 dBm to PASS.

**NOTE:** If values are obtained and any of the individual tests FAIL during AUTO TEST, press TEST LIST button on IFR 6000 and using UP/DOWN buttons scroll to the specific Failed test(s). Press SELECT TEST button, adjust IFR 6000 test set positioning anywhere within a 30 foot arc between the aircraft’s right wingtip and the nose as required, and Press RUN TEST button until PASS Message is received (this may take several test set position adjustments until IFR 6000 and aircraft Transponder “Sync up”). Press STOP TEST button. Repeat until all individual FAILED tests have achieved a PASS. It is not necessary to re-run AUTO TEST. AUTO TEST is a convenience feature only.

**NOTE:** If POWER/FREQ test Fails: After pressing RUN TEST, adjust IFR-6000 test set positioning while test is running until PASS message appears (this test performs a “Live” update of the dBm values). It may be required to position the test set anywhere within a 30 foot arc between the aircraft’s right wingtip and the nose. Press the STOP TEST button as soon as PASS message is displayed.

- (10) Make sure the following appears on the Transponder Test Set (IFR 6000):
  - “A CODE” = transponder code entered
  - “C ALT” = left PFD altitude indication +/- 100 ft.
  - “S CODE” = ICAO code assigned to this aircraft/tail number
  - “TAIL” = tail number assigned to this aircraft
  - “FLT ID” = same as tail number
  - “DF17 DETECTED” = YES (IF ADS-B OUT IS INSTALLED) / NO (IF ADS-B OUT IS NOT INSTALLED)
  - “AA” = ICAO code assigned to this aircraft/tail number (8 digit number in parenthesis)

- “FS” = IN-AIR
  - “VS” = IN-AIR
- (11) On MFD, press SYS along bottom of MFD. Use the small lower knob on the MFD to scroll to the SETUP page. On the SETUP page, press the SETTINGS softkey to bring up the SETTINGS page. At the bottom of the SETTINGS page, verify:
- (a) The “REGISTRATION NO” number (alphanumeric) matches the “TAIL” number (alphanumeric) displayed on the IFR 6000 (above).
- (12) The “ICAO 24-BIT (OCT)” number matches the “AA” ICAO 24-bit code displayed on the IFR 6000 (above).
- NOTE: If the aircraft’s registration number and/or ICAO 24-bit (octal) number are not present on the MFD’s SETTINGS page, the Aircraft Configuration File must be updated, refer to [AMM-31-40-00-051-801 – Aircraft Computer Systems - Maintenance Practices](#).
- (13) On the MFD, scroll to the SETUP tab, press the SENSOR Soft Key. Set the ADC PFD source selection from AUTO to ADC 2.
- (14) On the IFR 6000, press the XPDR button once.
- (15) Once XPDR - ALT ENCODER is displayed, press the SOURCE SELECT Soft Key until SOURCE - XPDR is displayed. Press the RUN TEST Soft Key.
- (16) Make sure that an altitude reported on IFR 6000 matches L PFD altitude indication +/- 100 ft.
- (17) On the MFD, set the ADC source back to AUTO.
- (18) Set the WOW Box Switches to W-on-W (on-ground).
- (19) Set XPDR 2 to STANDBY MODE.

---

## 11. Diversity Transponder-1 Adjustment/Tests with IFR-6000 Test Set Antenna

SUBTASK AMM-34-50-20-071-C-701-003-B

\* \* \* 0001-0104, 0113-0115, 0120, 0123-0124 POST SB 500-99-002; 0105-0112, 0116-0119, 0121-0122, 0125-0265 POST SB 500-99-005; AND 0266-0267

A. Begin adjustment/test as follows:

- (1) Install Antenna Clamp and Shield Assembly (part of Transponder Test Set IFR 6000) on lower transponder antenna (bottom of the center cabin/fuselage), in accordance with instructions in IFR 6000 Ramp Test Set Operation Manual.
  - (a) Position Antenna Clamp inside the slot in the Antenna Shield Plate, aligning captive screws into the respective screw holes.
  - (b) Tighten captive screws.
  - (c) Cover the transponder's Antenna with Antenna Shield. Loosen thumbscrews if necessary.

NOTE: It may be necessary to remove the unit under test's Antenna Guard if access to the transponders Antenna is restricted.
  - (d) Secure Antenna Shield by tightening thumbscrews.
- (2) Perform job setup, refer to [SUBTASK AMM-34-50-20-071-C-921-001](#).
- (3) Push ECB BY SYSTEM soft key. Scroll to FLCS using outer knob. Push inner knob to select. Scroll to the listed ECB using outer knob and highlight. Push "COLLAR" soft key. Push "CONFIRM COLLAR" soft key.
  - ECB - NOSE LDG GEAR (L AFT Bus)
  - ECB - L MAIN LDG GEAR (L AFT Bus)
  - ECB - R MAIN LDG GEAR (L AFT Bus)
- (4) Scroll to ENGINE using outer knob. Push inner knob to select. Scroll to the listed ECB using outer knob and highlight. Push "COLLAR" soft key. Push "CONFIRM COLLAR" soft key.
  - ECB - L ENG FIRE EXTNGR (L FWD Bus)
  - ECB - R ENG FIRE EXTNGR (R FWD Bus)
- (5) Clear any "MASTER CAUTIONS" and "MASTER WARNINGS" as needed.
- (6) Set both left and right PFD baro set to 29.92 (in/Hg.) on Autopilot Control Panel (ACP) by pushing BARO SET knob.
  - Make sure Baro Set on PFD annunciates "29.92 IN".

B. Diversity Transponder-1 Setup

- (1) Use the small rotary knob on the left PFD to select XPDR page.

NOTE: The XPDR select page times out and switches back to the COM page after 30 seconds. Select XPDR page from time to time during this test.
- (2) Push ACTIVE soft key (upper right button) on the left PFD to select D-XPDR1.

- 
- (3) Make sure that the selected transponder is in Standby Mode.
  - (4) Push CODE soft key on left PFD and enter the transponder code used for this test or 1200.
- C. Diversity Transponder-1 MODE A,C,S Test using Transponder Test Set, IFR6000 (Upper Antenna)
- (1) Power up the Transponder Test Set (IFR 6000). After tester performs Self Test, push SETUP button on the test set to bring up the SETUP-XPDR page. If necessary, continue pressing SETUP button until tester cycles to SETUP-XPDR page.
  - (2) On the Transponder Test Set (IFR 6000)'s SETUP-XPDR page, use NEXT PARAM or PREV PARAM soft keys to select each parameter, and the "arrow" DATA keys to set the values listed below.
    - ANTENNA: TOP
    - RF PORT: ANTENNA
    - ANT RANGE-TOP: 18 ft.
    - ANT HEIGHT-TOP: 7 ft.
    - ANT RANGE-BOTTOM: 18 ft.
    - ANT HEIGHT-BOTTOM: 1 ft.
    - DIR CABLE LOSS: Ignore
    - ANT CABLE: 1 ft.
    - ANT CABLE LOSS: As marked on blue cable (should be 0.1 dB)
    - ANT GAIN (dBi) - 1.03 GHz: As marked on test set antenna
    - ANT GAIN (dBi) - 1.09 GHz: As marked on test set antenna
    - UUT ADDRESS: AUTO
    - MANUAL AA: Ignore
    - DIVERSITY TEST: ON
    - PWR LIM: FAR 43
    - CHECK CAP: YES
  - (3) Push XPDR button to go to the XPDR-AUTO TEST page.
  - (4) Push CONFIG soft key to display the XPDR-CONFIG SCREEN page.
  - (5) On the XPDR-CONFIG SCREEN, scroll to GENERIC MODE S using the UP/Down DATA keys.
  - (6) With GENERIC MODE S highlighted, push RETURN soft key to confirm selection. This will also cause a return to the XPDR-AUTO TEST page.
  - (7) Set the WOW Box Switches to W-off-W (airborne).
  - (8) Push RUN TEST soft key to start AUTO TEST. The tester will sequence through separate tests, after which a "PASS" message should be displayed.

- (9) Top ERP should be between 48 to 60 dBm and MTL should be between -68 to -80 dBm to PASS.

**NOTE:** If values are obtained and any of the individual tests FAIL during AUTO TEST, press TEST LIST button on IFR 6000 and using UP/DOWN buttons scroll to the specific Failed test(s). Press SELECT TEST button, adjust IFR 6000 test set positioning anywhere within a 30 foot arc between the aircraft's right wingtip and the nose as required, and Press RUN TEST button until PASS Message is received (this may take several test set position adjustments until IFR 6000 and aircraft Transponder "Sync up"). Press STOP TEST button. Repeat until all individual FAILED tests have achieved a PASS. It is not necessary to re-run AUTO TEST. AUTO TEST is a convenience feature only.

**NOTE:** If POWER/FREQ test Fails: After pressing RUN TEST, adjust IFR-6000 test set positioning while test is running until PASS message appears (this test performs a "Live" update of the dBm values). It may be required to position the test set anywhere within a 30 foot arc between the aircraft's right wingtip and the nose. Press the STOP TEST button as soon as PASS message is displayed

- (10) Make sure the following appears on the Transponder Test Set (IFR 6000):
- "A CODE" = transponder code entered
  - "C ALT" = left PFD altitude indication +/- 100 ft.
  - "S CODE" = ICAO code assigned to this aircraft/tail number
  - "TAIL" = tail number assigned to this aircraft
  - "FLT ID" = same as tail number
  - "DF17 DETECTED" = YES (IF ADS-B OUT IS INSTALLED) / NO (IF ADS-B OUT IS NOT INSTALLED)
  - "AA" = ICAO code assigned to this aircraft/tail number (8 digit number in parenthesis)
  - "FS" = IN-AIR
  - "VS" = IN-AIR
- (11) On MFD, press SYS along bottom of MFD. Use the small lower knob on the MFD to scroll to the SETUP page. On the SETUP page, press the SETTINGS soft key to bring up the SETTINGS page. At the bottom of the SETTINGS page, verify:
- (a) The "REGISTRATION NO" number (alphanumeric) matches the "TAIL" number (alphanumeric) displayed on the IFR 6000 (above).
- (b) The "ICAO 24-BIT (OCT)" number matches the "AA" ICAO 24-bit code displayed on the IFR 6000 (above).

**NOTE:** If the aircraft's registration number and/or ICAO 24-bit (octal) number are not present on the MFD's SETTINGS page, the Aircraft Configuration File must be updated, refer to [AMM-31-40-00-051-801 – Aircraft Computer Systems - Maintenance Practices](#). Steps (10) through this step must then be repeated.

- 
- (12) On the MFD, scroll to the SETUP tab, press the SENSOR Soft Key. Set the ADC PFD source selection from AUTO to ADC 2.
  - (13) On the IFR 6000, press the XPDR button once.
  - (14) Once XPDR - ALT ENCODER is displayed, press the SOURCE SELECT Soft Key until SOURCE - XPDR is displayed. Press the RUN TEST Soft Key.
  - (15) Make sure that an altitude reported on IFR 6000 matches L PFD altitude indication +/- 100 ft.
  - (16) On the MFD, set the ADC source back to AUTO.
  - (17) Set the WOW Box Switches to W-on-W (on-ground).
  - (18) Set D-XPDR 1 to STANDBY MODE.
- D. Diversity Transponder-1 MODE A,C,S Test using Transponder Test Set (IFR 6000) (Lower Antenna)
- (1) Remove Antenna Clamp and Shield Assembly (part of Transponder Test Set IFR 6000) from lower transponder antenna (bottom center cabin/fuselage).
  - (2) Install Antenna Clamp and Shield Assembly (part of Transponder Test Set IFR 6000) on upper transponder antenna (top of the center cabin/fuselage), in accordance with instructions in IFR 6000 Ramp Test Set Operation Manual.
  - (3) Pre-position the Transponder Test Set IFR 6000 antenna to point at the aircraft's lower Transponder 2 antenna, (bottom of the center cabin/fuselage).
  - (4) Push XPDR button to go to the XPDR-AUTO TEST page.
  - (5) Push CONFIG soft key to display the XPDR-CONFIG SCREEN page.
  - (6) On the XPDR-CONFIG SCREEN, scroll to GENERIC MODE S using the UP/Down DATA keys.
  - (7) With GENERIC MODE S highlighted, push RETURN soft key to confirm selection. This will also cause a return to the XPDR-AUTO TEST page.
  - (8) Set the WOW Box Switches to W-off-W (airborne).
  - (9) Push RUN TEST soft key to start AUTO TEST. The tester will sequence through separate tests, after which a "PASS" message should be displayed.

- 
- (10) ERP should be between 48 to 60 dBm and MTL should be between -68 to -80 dBm to PASS.

NOTE: If values are obtained and any of the individual tests FAIL during AUTO TEST, press TEST LIST button on IFR 6000 and using UP/DOWN buttons scroll to the specific Failed test(s). Press SELECT TEST button, adjust IFR 6000 test set positioning anywhere within a 30 foot arc between the aircraft's right wingtip and the nose as required, and Press RUN TEST button until PASS Message is received (this may take several test set position adjustments until IFR 6000 and aircraft Transponder "Sync up"). Press STOP TEST button. Repeat until all individual FAILED tests have achieved a PASS. It is not necessary to re-run AUTO TEST. AUTO TEST is a convenience feature only.

NOTE: If POWER/FREQ test Fails: After pressing RUN TEST, adjust IFR-6000 test set positioning while test is running until PASS message appears (this test performs a "Live" update of the dBm values). It may be required to position the test set anywhere within a 30 foot arc between the aircraft's right wingtip and the nose. Press the STOP TEST button as soon as PASS message is displayed

- (11) Remove Antenna Clamp and Shield Assembly.  
(12) Set the WOW Box Switches to W-on-W (on-ground).

---

## 12. Diversity Transponder-2 Adjustment/Tests with IFR-6000 Test Set Antenna

SUBTASK AMM-34-50-20-071-C-701-004-B

\* \* \* 0001-0104, 0113-0115, 0120, 0123-0124 POST SB 500-99-002; 0105-0112, 0116-0119, 0121-0122, 0125-0265 POST SB 500-99-005; AND 0266-0267

A. Begin adjustment/test as follows:

- (1) Install Antenna Clamp and Shield Assembly (part of Transponder Test Set IFR 6000) on lower transponder antenna (bottom of the center cabin/fuselage), in accordance with instructions in IFR 6000 Ramp Test Set Operation Manual.
  - (a) Position Antenna Clamp inside the slot in the Antenna Shield Plate, aligning captive screws into the respective screw holes.
  - (b) Tighten captive screws.
  - (c) Cover the transponder's Antenna with Antenna Shield. Loosen thumbscrews if necessary.

NOTE: It may be necessary to remove the unit under test's Antenna Guard if access to the transponders Antenna is restricted.
  - (d) Secure Antenna Shield by tightening thumbscrews.
- (2) Perform job setup, refer to [SUBTASK AMM-34-50-20-071-C-921-001](#).
- (3) Push ECB BY SYSTEM soft key. Scroll to FLCS using outer knob. Push inner knob to select. Scroll to the listed ECB using outer knob and highlight. Push "COLLAR" soft key. Push "CONFIRM COLLAR" soft key.
  - ECB - NOSE LDG GEAR (L AFT Bus)
  - ECB - L MAIN LDG GEAR (L AFT Bus)
  - ECB - R MAIN LDG GEAR (L AFT Bus)
- (4) Scroll to ENGINE using outer knob. Push inner knob to select. Scroll to the listed ECB using outer knob and highlight. Push "COLLAR" soft key. Push "CONFIRM COLLAR" soft key.
  - ECB - L ENG FIRE EXTNGR (L FWD Bus)
  - ECB - R ENG FIRE EXTNGR (R FWD Bus)
- (5) Clear any "MASTER CAUTIONS" and "MASTER WARNINGS" as needed.
- (6) Set both left and right PFD baro set to 29.92 (in/Hg.) on Autopilot Control Panel (ACP) by pushing BARO SET knob.
  - Make sure Baro Set on PFD annunciates "29.92 IN".

B. Diversity Transponder-2 Setup

- (1) Use the small rotary knob on the left PFD to select XPDR page.

NOTE: The XPDR select page times out and switches back to the COM page after 30 seconds. Select XPDR page from time to time during this test.
- (2) Push ACTIVE soft key (upper right button) on the left PFD to select D-XPDR2.

- 
- (3) Make sure that D-XPDR2 is in Standby Mode.
  - (4) Push CODE soft key on left PFD and enter the transponder code used for this test or 1200.
- C. Diversity Transponder-2 MODE A,C,S Test using Transponder Test Set, IFR6000 (Upper Antenna)
- (1) Power up the Transponder Test Set (IFR 6000). After tester performs Self Test, push SETUP button on the test set to bring up the SETUP-XPDR page. If necessary, continue pressing SETUP button until tester cycles to SETUP-XPDR page.
  - (2) On the Transponder Test Set (IFR 6000)'s SETUP-XPDR page, use NEXT PARAM or PREV PARAM soft keys to select each parameter, and the "arrow" DATA keys to set the values listed below.
    - ANTENNA: TOP
    - RF PORT: ANTENNA
    - ANT RANGE-TOP: 18 ft.
    - ANT HEIGHT-TOP: 7 ft.
    - ANT RANGE-BOTTOM: 18 ft.
    - ANT HEIGHT-BOTTOM: 1 ft.
    - DIR CABLE LOSS: Ignore
    - ANT CABLE: 1 ft.
    - ANT CABLE LOSS: As marked on blue cable (should be 0.1 dB)
    - ANT GAIN (dBi) - 1.03 GHz: As marked on test set antenna
    - ANT GAIN (dBi) - 1.09 GHz: As marked on test set antenna
    - UUT ADDRESS: AUTO
    - MANUAL AA: Ignore
    - DIVERSITY TEST: ON
    - PWR LIM: FAR 43
    - CHECK CAP: YES
  - (3) Push XPDR button to go to the XPDR-AUTO TEST page.
  - (4) Push CONFIG soft key to display the XPDR-CONFIG SCREEN page.
  - (5) On the XPDR-CONFIG SCREEN, scroll to GENERIC MODE S using the UP/Down DATA keys.
  - (6) With GENERIC MODE S highlighted, push RETURN soft key to confirm selection. This will also cause a return to the XPDR-AUTO TEST page.
  - (7) Set the WOW Box Switches to W-off-W (airborne).
  - (8) Push RUN TEST soft key to start AUTO TEST. The tester will sequence through separate tests, after which a "PASS" message should be displayed.

- (9) Top ERP should be between 48 to 60 dBm and MTL should be between -68 to -80 dBm to PASS.

**NOTE:** If values are obtained and any of the individual tests FAIL during AUTO TEST, press TEST LIST button on IFR 6000 and using UP/DOWN buttons scroll to the specific Failed test(s). Press SELECT TEST button, adjust IFR 6000 test set positioning anywhere within a 30 foot arc between the aircraft's right wingtip and the nose as required, and Press RUN TEST button until PASS Message is received (this may take several test set position adjustments until IFR 6000 and aircraft Transponder "Sync up"). Press STOP TEST button. Repeat until all individual FAILED tests have achieved a PASS. It is not necessary to re-run AUTO TEST. AUTO TEST is a convenience feature only.

**NOTE:** If POWER/FREQ test Fails: After pressing RUN TEST, adjust IFR-6000 test set positioning while test is running until PASS message appears (this test performs a "Live" update of the dBm values). It may be required to position the test set anywhere within a 30 foot arc between the aircraft's right wingtip and the nose. Press the STOP TEST button as soon as PASS message is displayed

- (10) Make sure the following appears on the Transponder Test Set (IFR 6000):
- "A CODE" = transponder code entered
  - "C ALT" = left PFD altitude indication +/- 100 ft.
  - "S CODE" = ICAO code assigned to this aircraft/tail number
  - "TAIL" = tail number assigned to this aircraft
  - "DF17 DETECTED" = YES (IF ADS-B OUT IS INSTALLED) / NO (IF ADS-B OUT IS NOT INSTALLED)
  - "FLT ID" = same as tail number
  - "AA" = ICAO code assigned to this aircraft/tail number (8 digit number in parenthesis)
  - "FS" = IN-AIR
  - "VS" = IN-AIR
- (11) On MFD, press SYS along bottom of MFD. Use the small lower knob on the MFD to scroll to the SETUP page. On the SETUP page, press the SETTINGS softkey to bring up the SETTINGS page. At the bottom of the SETTINGS page, verify:
- (a) The "REGISTRATION NO" number (alphanumeric) matches the "TAIL" number (alphanumeric) displayed on the IFR 6000 (above).
  - (b) The "ICAO 24-BIT (OCT)" number matches the "AA" ICAO 24-bit code displayed on the IFR 6000 (above).

**NOTE:** If the aircraft's registration number and/or ICAO 24-bit (octal) number are not present on the MFD's SETTINGS page, the Aircraft Configuration File must be updated, refer to [AMM-31-40-00-051-801 – Aircraft Computer Systems - Maintenance Practices](#). Steps (10) through this step must then be repeated.

- (12) On the MFD, scroll to the SETUP tab, press the SENSOR Soft Key. Set the ADC PFD source selection from AUTO to ADC 2.
  - (13) On the IFR 6000, press the XPDR button once.
  - (14) Once XPDR - ALT ENCODER is displayed, press the SOURCE SELECT Soft Key until SOURCE - XPDR is displayed. Press the RUN TEST Soft Key.
  - (15) Make sure that an altitude reported on IFR 6000 matches L PFD altitude indication +/- 100 ft.
  - (16) On the MFD, set the ADC source back to AUTO.
  - (17) Set the WOW Box Switches to W-on-W (on-ground).
  - (18) Set D-XPDR 2 to STANDBY MODE.
- D. Diversity Transponder-2 MODE A,C,S Test using Transponder Test Set (IFR 6000) (Lower Antenna)
- (1) Remove Antenna Clamp and Shield Assembly (part of Transponder Test Set IFR 6000) from lower transponder antenna (bottom of the center cabin/fuselage).
  - (2) Install Antenna Clamp and Shield Assembly (part of Transponder Test Set IFR 6000) on upper transponder antenna (top of the center cabin/fuselage), in accordance with instructions in IFR 6000 Ramp Test Set Operation Manual.
  - (3) Pre-position the Transponder Test Set IFR 6000 antenna to point at the aircraft's lower Transponder 2 antenna (bottom of the center cabin/fuselage).
  - (4) On the Transponder Test Set (IFR 6000) SETUP-XPDR page, use NEXT PARAM or PREV PARAM softkeys to select each parameter, and the "arrow" DATA keys to set the values listed below:
    - ANTENNA: BOTTOM
    - RF PORT: ANTENNA
    - ANT RANGE-TOP: 18 ft.
    - ANT HEIGHT-TOP: 7 ft.
    - ANT RANGE-BOTTOM: 18 ft.
    - ANT HEIGHT-BOTTOM: 1 ft.
    - DIR CABLE LOSS: Ignore
    - ANT CABLE: 1 ft.
    - ANT CABLE LOSS: As marked on blue cable (should be 0.1 dB)
    - ANT GAIN (dBi) - 1.03 GHz: As marked on test set antenna
    - ANT GAIN (dBi) - 1.09 GHz: As marked on test set antenna
    - UUT ADDRESS: AUTO
    - MANUAL AA: Ignore
    - DIVERSITY TEST: ON
    - PWR LIM: FAR 43

- CHECK CAP: YES
- (5) Push XPDR button to go to the XPDR-AUTO TEST page.
  - (6) Push CONFIG soft key to display the XPDR-CONFIG SCREEN page.
  - (7) On the XPDR-CONFIG SCREEN, scroll to GENERIC MODE S using the UP/Down DATA keys.
  - (8) With GENERIC MODE S highlighted, push RETURN soft key to confirm selection. This will also cause a return to the XPDR-AUTO TEST page.
  - (9) Set the WOW Box Switches to W-off-W (airborne).
  - (10) Push RUN TEST soft key to start AUTO TEST. The tester will sequence through separate tests, after which a “PASS” message should be displayed.
  - (11) Bottom ERP should be between 48 to 60 dBm and MTL should be between -68 to -80 dBm to PASS.

**NOTE:** If values are obtained and any of the individual tests FAIL during AUTO TEST, press TEST LIST button on IFR 6000 and using UP/DOWN buttons scroll to the specific Failed test(s). Press SELECT TEST button, adjust IFR 6000 test set positioning anywhere within a 30 foot arc between the aircraft’s right wingtip and the nose as required, and Press RUN TEST button until PASS Message is received (this may take several test set position adjustments until IFR 6000 and aircraft Transponder “Sync up”). Press STOP TEST button. Repeat until all individual FAILED tests have achieved a PASS. It is not necessary to re-run AUTO TEST. AUTO TEST is a convenience feature only.

**NOTE:** If POWER/FREQ test Fails: After pressing RUN TEST, adjust IFR-6000 test set positioning while test is running until PASS message appears (this test performs a “Live” update of the dBm values). It may be required to position the test set anywhere within a 30 foot arc between the aircraft’s right wingtip and the nose. Press the STOP TEST button as soon as PASS message is displayed

- (12) Remove Antenna Clamp and Shield Assembly from aircraft and stow in IFR 6000 ramp test set kit.
- (13) Remove Antenna Clamp and Shield Assembly and stow in ramp test kit.
- (14) Set the WOW Box Switches to W-on-W (on-ground).

---

### 13. ADS-B Out System Test

SUBTASK AMM-34-50-20-071-C-701-005

\*\*\* ALL POST MB 500-31-016, MB 500-31-018 AND MB 500-34-030

#### A. ADS-B Out Test Set-Up

- (1) Power up the Transponder Test Set (IFR 6000).

NOTE: To check if IFR 6000 has the ADS-B test, press SETUP to display SETUP-GENERAL page. Press INFO and check that ADSB is listed in the OPTIONS area.

NOTE: If no transponder test set with the ADS-B test capability is available, as an additional or alternate method of making sure of proper operation and performance of the installed ADS-B OUT function, the FAA Public ADS-B Performance Report (PAPR) may be requested after a Return to Service (RTS) flight. This report request may be made online on the FAA web site at the ADS-B related area.

- (2) After the Transponder Test Set (IFR 6000) performs Self Test, push SETUP button on the test set to bring up the SETUP-XPDR page. If necessary, continue pressing SETUP button until SETUP XPDR screen is displayed.
- (3) Press ADS-B SETUP Soft Key to display the SETUP-ADSB Setup Screen. Use NEXT PARAM and PREV PARAM Soft Keys to select each parameter. Configure the setup parameters as shown in the following example:

POS DECODE: GLOBAL

LAT: 35 02 13.80 N

LON: 106 37 1.80 W

BARO PRES ALT: 5450 ft.

ADSB MON: DF17

NOTE: LAT and LON must be set to the values corresponding to the location of the test as shown on the MFD (or, if installed, GPS 400W unit) GPS Status Page. In this example, for the test set entry, the position data corresponds to the MFD (or, if installed, GPS 400W) displayed position data of N35°02.23' W106°37.03', where seconds are represented as a fraction of a minute, and, therefore, the entered seconds' values are 0.23 x 60 seconds = 13.80 seconds and 0.03 x 60 seconds = 1.80 seconds, respectively.

BARO PRES ALT is a test reference and must be set to the value corresponding to the tested aircraft Pressure Altitude. Therefore, using the Autopilot Control Panel (ACP) controls, set Baro Correction to 29.92 inHg, and then enter the altitude value displayed on the PFD into BARO PRES ALT entry field of IFR 6000. This entry may not be available in some IFR 6000 test sets.

- (4) Make sure aircraft power is off.
- (5) Set WOW Box switches to W-on-W (on-ground).
- (6) On IFR 6000, press XPDR mode Key until ADSB/GICB/UAT MAIN menu is displayed. Press the ADS-B MON Soft Key to display the ADS-B MON list screen.

- (7) Power up the aircraft.

**NOTE:** After initial system installation, the initial acquisition of GPS position can take up to 20 minutes. Subsequent acquisitions should take no more than 150 seconds.

- (8) If installed, make sure that the ADS-B FAIL indicator is illuminated in white color. Refer to [Fig. 502, Sheet 1](#). Make sure the ADS-B FAIL indicator extinguishes within 150 seconds or less after power up.

- (9) Make sure that no ADS-B related CAS messages are displayed.

**NOTE:** It may take up to 150 seconds for the CAS messages to clear.

- (10) If installed, allow for the amber INTEG message on the Left GPS 400W unit to extinguish.

**NOTE:** It may take up to 150 seconds for the GPS unit to obtain the GPS position and extinguish the INTEG message.

- (11) Make sure that the Baro Correction is set to 29.92 inHg. Use the Autopilot Control Panel (ACP) to set.

- (12) On either PFD, select transponder under test as ACTIVE transponder and enter transponder test squawk code as assigned by Air Traffic Control for the test. Transponder should be in STBY mode.

- (13) Set WOW Box switches to W-off-W (airborne). Transponder should transition to ALT mode.

#### SUBTASK AMM-34-50-20-071-C-701-006

\*\*\* ALL POST MB 500-31-016, MB 500-31-018 AND MB 500-34-030

#### A. ADS-B Out Functional Test

- (1) Do ADS-B Out Test Set-Up. Refer to [SUBTASK AMM-34-50-20-071-C-701-005](#).
- (2) In order to check that ADS-B OUT function is active, for each installed transponder, except for noted limitation, perform the following test using IFR 6000 or an equivalent test set.

Limitation: If the aircraft is equipped with Garmin GPS 400W, this test applies to Transponder 1 (XPDR 1) only.

- (a) On IFR 6000, press RUN TEST soft key to start test. When a specific extended squitter BDS is captured, AVAIL will be displayed to the right of the BDS name. Use Data Keys to select specific BDS and press BDS DATA soft key to display selected BDS screen. Press Return soft key to return to ADSB MON list screen or press PREV TEST or NEXT TEST soft keys to select specific ADS-B MON BDS screens.
- (b) Select BDS 0,5 AIRBORNE POS and check the following data:  
AA = matches aircraft ICAO code displayed on the MFD Settings Page  
LAT = comparable to the aircraft latitude.  
LON = comparable to the aircraft longitude.  
BARO PRES ALT = matches aircraft altitude displayed on the L PFD within  $\pm 125$  ft.

---

**SURVEILLANCE STATUS = NO INFO**

SUBTASK AMM-34-50-20-071-C-701-007

\* \* \* ALL POST MB 500-31-016, MB 500-31-018 AND MB 500-34-030

**A. ADS-B Parameter Test**

- (1) Do ADS-B Out Test Set-Up. Refer to [SUBTASK AMM-34-50-20-071-C-701-005](#) or continue testing using the set-up from [SUBTASK AMM-34-50-20-071-C-701-004-A](#) or [SUBTASK AMM-34-50-20-071-C-701-004-B](#).
- (2) For each installed transponder (except for noted limitation), perform the following procedure.  
Limitation: If the aircraft is equipped with Garmin GPS 400W, this test applies to Transponder 1 (XPDR 1) only.
  - (a) Select BDS 0,8 IDENT & CAT and check the following data:  
AA = matches aircraft ICAO code displayed on the MFD Settings Page  
FLIGHT ID = Aircraft Registration number (N-number for US registered aircraft)  
EMIT CAT = LIGHT
  - (b) Select BDS 6,1 A/C STATUS ST1 and check the following data:  
AA = matches aircraft ICAO code displayed on the MFD Settings Page  
MODE A (4096) CODE = Entered Squawk Code from the PFD
  - (c) Select BDS 6,2 TSS SUBTYPE 1 and check the following data:  
AA = matches aircraft ICAO code displayed on the MFD Settings Page  
SIL ≥ 3  
TCAS OP = NO  
SELECTED ALTITUDE = comparable Selected Altitude using ACP controls  
BARO PRESS = comparable selected Baro Pressure Setting
  - (d) Select BDS 6,5 A/C OP STATUS AIR and check the following data:  
AA = matches aircraft ICAO code displayed on the MFD Settings Page  
VERSION = 2 - DO-260B  
1090 = 0  
SIL ≥ 3
  - (e) On IFR 6000, press STOP TEST.
  - (f) Set WOW Box switches to W-on-W (on-ground).
  - (g) Set active XPDR = ALT mode.
  - (h) Press RUN TEST soft key to start test.
  - (i) Select BDS 0,6 SURFACE POS and check the following data:  
AA = matches aircraft ICAO code displayed on the MFD Settings Page  
LAT = comparable to the aircraft latitude  
LON = comparable to the aircraft longitude  
MOVEMENT = STOPPED  
HDG = current aircraft heading on the L PFD within 1 deg
  - (j) Select BDS 0,8 IDENT & CAT and check the following data:  
AA = matches aircraft ICAO code displayed on the MFD Settings Page  
FLIGHT ID = Aircraft Registration number

EFFECTIVITY: NOTED

34-50-20  
CONFIG C  
Page 538  
Sep 30/20

EMIT CAT = LIGHT

- (k) Select BDS 6,1 A/C STATUS ST1 and check the following data:  
AA = matches aircraft ICAO code displayed on the MFD Settings Page  
MODE A (4096) CODE = Entered Squawk Code from the PFD  
EMERG/PRIOR CODE = 0 - NO EMERGENCY
- (l) Select BDS 6,5 A/C STATUS SUR and check the following data:  
AA = matches aircraft ICAO code displayed on the MFD Settings Page  
VERSION = 2 - DO-260B  
1090 = 0  
ANT OFF = RT 0 m, 6 m (for the Garmin GPS 400W equipped aircraft, ANT OFF  
= RT 0 m, 4 m)  
SIL ≥ 3  
LN/WD = 1 - <15m; <23m.
- (m) On IFR 6000, press STOP TEST.

#### **14. ADS-B FAIL Indicator Functional Test**

SUBTASK AMM-34-50-20-071-C-701-008

\*\*\* ALL POST MB 500-34-030

NOTE: This procedure is required only upon ADS-B FAIL Indicator replacement or removal and installation.

##### **A. ADS-B FAIL Indicator Functional Test**

NOTE: After initial system installation, the initial acquisition of GPS position can take up to 20 minutes. Subsequent acquisitions should take no more than 150 seconds. This test must be done prior to GPS position acquisition and extinguishing of the ADS-B FAIL indicator.

- (1) Power up the aircraft.
- (2) Make sure that the ADS-B FAIL indicator is illuminated in white color. Refer to [Fig. 503, Sheet 1](#).
- (3) Check that the brightness of the indicator can be adjusted with the Master Dim switch on the Center Switch Panel (CSP).
- (4) Make sure the ADS-B FAIL indicator extinguishes within 150 seconds or less after power up.

#### **15. Job Close-Up**

SUBTASK AMM-34-50-20-071-C-921-002

\*\*\* 0001-0104, 0113-0115, 0120, 0123-0124 POST SB 500-99-002; 0105-0112, 0116-0119, 0121-0122, 0125-0265 POST SB 500-99-005; AND 0266-0267; ALL POST MB 500-31-016, MB 500-31-018. and MB 500-34-030

- A. Set WOW Box switches to W-on-W (on-ground)
- B. Reset the collared ECB's. Refer to AMM-20-00-03-051-801 – Prepare Anti-Ice Systems For Maintenance.

EFFECTIVITY: NOTED

34-50-20  
CONFIG C  
Page 539  
Sep 30/20

- 
- C. Scroll to FLCS using outer knob. Press inner knob to select. Scroll to the listed ECB using outer knob and highlight. Push “RESET” Soft key. Press “CONFIRM RESET” soft key.
- ECB - NOSE LDG GEAR (L AFT Bus)
  - ECB - L MAIN LDG GEAR (L AFT Bus)
  - ECB - R MAIN LDG GEAR (L AFT Bus)
- D. Scroll to ENGINE using outer knob. Press inner knob to select. Scroll to the listed ECB using outer knob and highlight. Push “RESET” Soft key. Press “CONFIRM RESET” soft key.
- ECB - L ENG FIRE EXTNGR (L FWD Bus)
  - ECB - R ENG FIRE EXTNGR (R FWD Bus)
- E. Power down the aircraft by setting the SYS BATT and START BATT switches to OFF and the BUS TIE to OPEN.
- F. Disconnect WOW Box from aircraft. Refer to AMM-20-00-04-051-801 – Weight On Wheels (WOW) Box - Connect/Disconnect.
- G. If on jacks, lower aircraft and remove jacks. Refer to [AMM-07-10-00-051-801 – Jacking - Maintenance Practices](#).
- H. If applicable, call the local control tower and tell them the transponder test is complete.
- I. Remove all tools, equipment and unwanted material from work area.
- J. Disconnect external power. Refer to [AMM-24-40-00-051-801 – External Power - Maintenance Practices](#).
- K. If all other maintenance is complete, return aircraft to service. Refer to [AMM-20-00-02-051-801 – Return To Service \(After Maintenance\)](#).

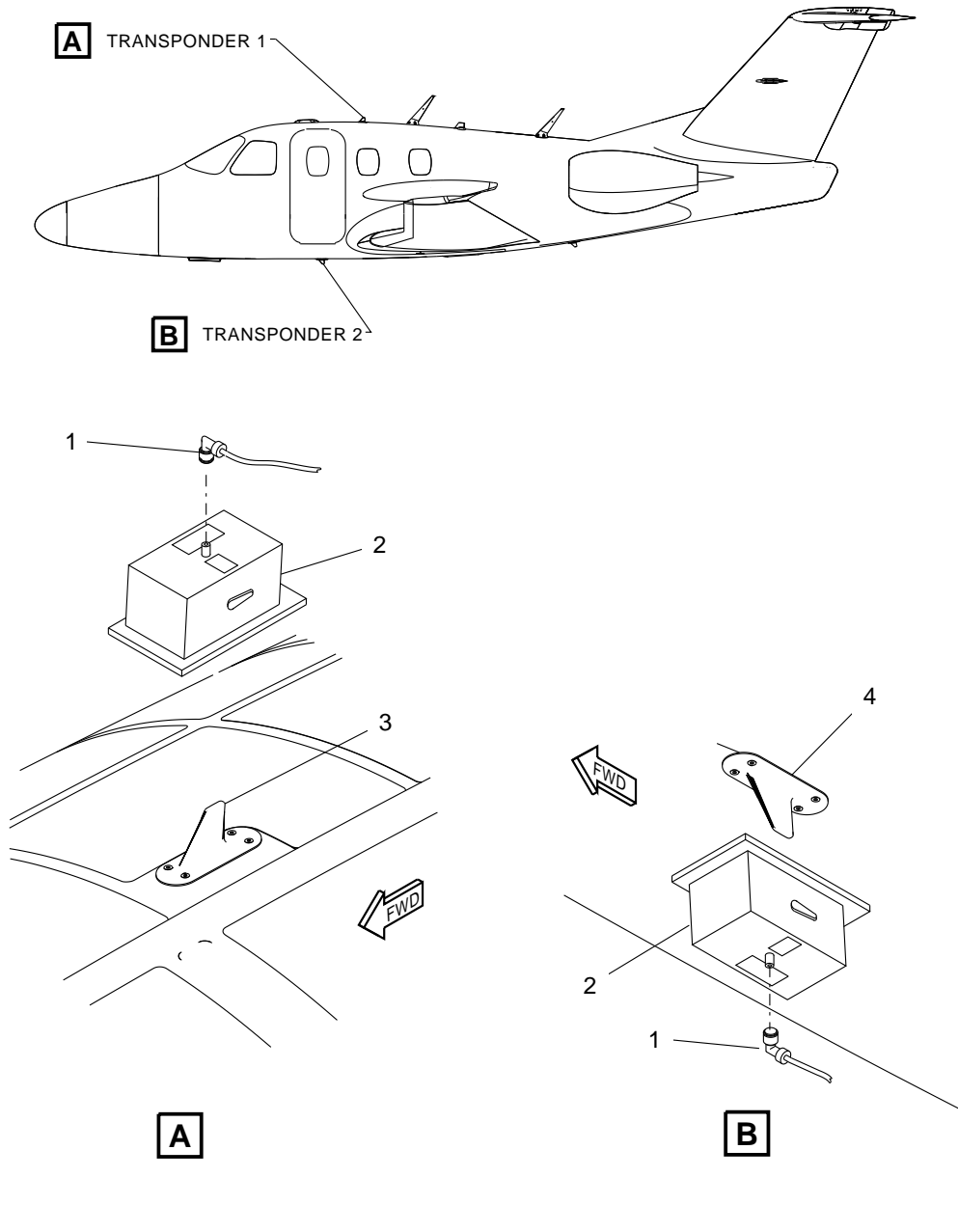

**Transponder - Adjustment/Test**  
**Figure 501 (Sheet 1 of 1)**

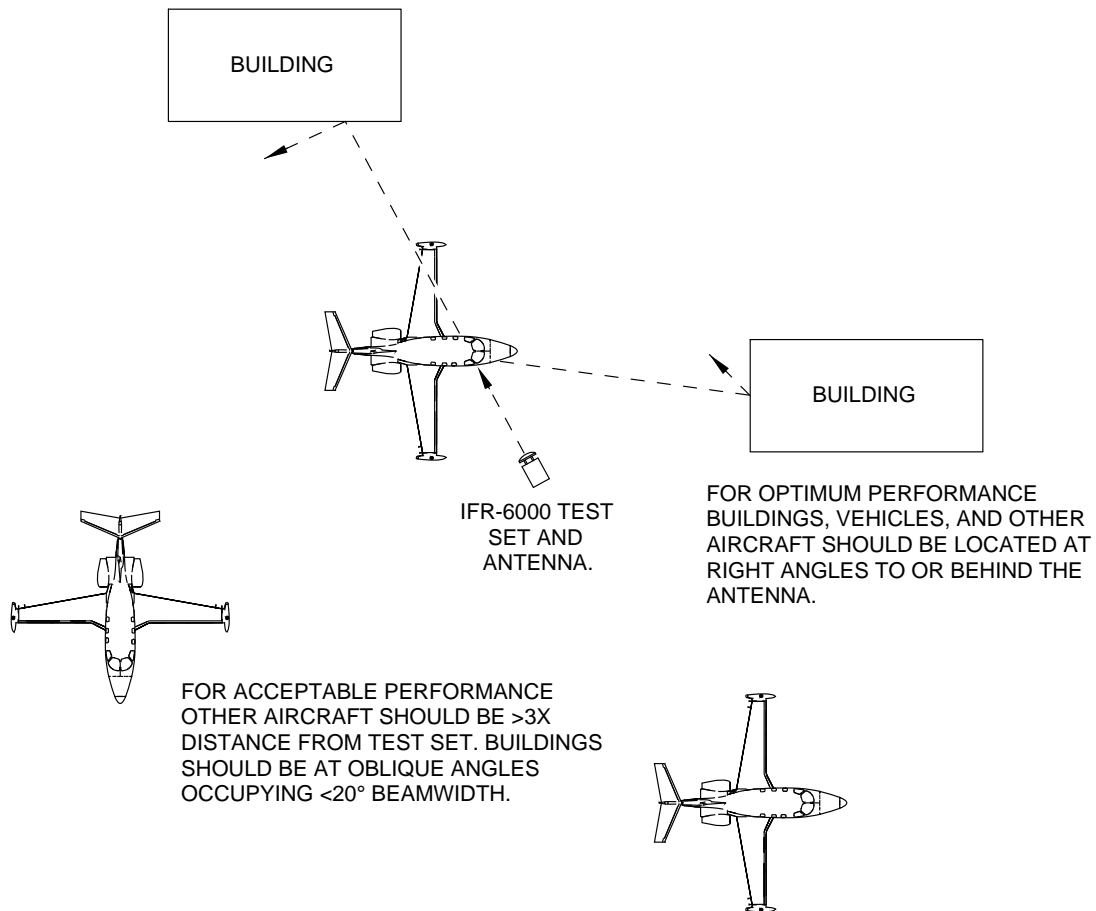
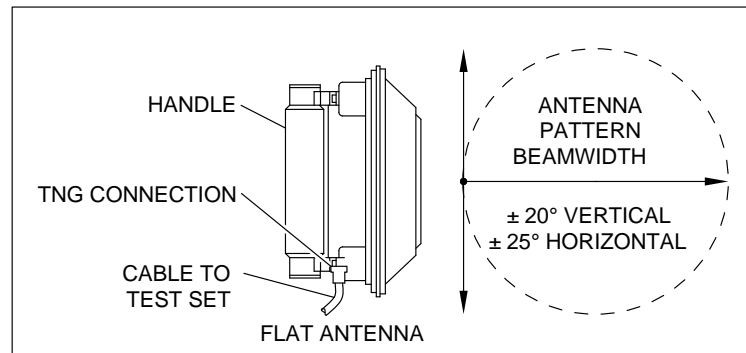

5081043A

**Transponder - Adjustment/Test**  
**Figure 502 (Sheet 1 of 1)**

\*\*\* 0001-0104, 0113-0115, 0120, 0123-0124 POST SB 500-99-002; 0105-0112, 0116-0119, 0121-0122, 0125-0265 POST SB 500-99-005; AND 0266-0267

EFFECTIVITY: NOTED

34-50-20  
CONFIG C  
Page 542  
Sep 30/20



**ADS-B Fail Annunciation**  
**Figure 503 (Sheet 1 of 1)**  
\* \* \* ALL POST MB 500-34-030

THIS PAGE INTENTIONALLY LEFT BLANK

---

## **ADS-B OUT WITH GPS 3 - DESCRIPTION AND OPERATION**

AMM-34-50-21-081-801

### **1. Introduction**

- A. The Automatic Dependent Surveillance – Broadcast Out (ADS-B Out) provides air traffic controllers with real-time position information.
- B. ADS-B Out with GPS 3 system have these components:
  - One GPS antenna (GPS 2) (Combination Antenna)
  - One GPS 2 Antenna Splitter
  - One GPS/Wide Area Augmentation System (WAAS) sensor GPS 3 (GDL 88)
  - One ADS-B fail annunciator

### **2. Description**

- A. ADS-B OUT System with Dual Transponder System (Diversity or Non-Diversity).
  - (1) The Dual Transponder System, both transponders are the Enhanced Mode S transponders with or without the antenna diversity by Garmin, models GTX–33(D). Both transponders, XPDR 1 and XPDR 2, are located behind the Instrument Panel (IP).
  - (2) The GPS 3 (GDL 88) unit is located beneath the cabin floor on the left side of the aircraft.
  - (3) The GPS 2 Antenna Splitter is located under the aft baggage compartment floor.
  - (4) ADS-B system failure annunciation (based on the GPS 3 position source failure) is located in the cockpit on the lower left instrument panel.

### **3. Operation**

- A. The ADS-B OUT system utilizes the Extended Squitter (ES) capability of the transponders.

GPS 3 (GDL 88) with internal GPS provides the necessary ADS-B OUT compliant position data to the already installed transponders. GPS 3 outputs the ADS-B OUT compliant GPS data to both transponders via a dedicated RS-232 line.
- B. GPS 3 (GDL 88) makes use of the GPS 2 antenna through the GPS 2 Antenna Splitter, which is located below the aft baggage compartment floor.
- C. The ADS-B system failure indicator provides an advisory message to the pilot via a white ADS-B FAIL indication if any of the following events occur:
  - GPS 3 loses its integrity
  - During R Smoke Clear procedure
  - Manually pulling ECB
  - Battery-only Load shed
  - Unintended power loss

THIS PAGE INTENTIONALLY LEFT BLANK

### ADS-B - ADJUSTMENT/TEST

AMM-34-50-21-071-801

#### 1. General

- A. This task gives procedures to do the adjustment/test of the ADS-B.

NOTE: ADS-B test is only required, if the ADS-B function is enabled.

- There are two testing setup methods, the preferred method is with the use of a transponder antenna coupler to limit emissions that may interfere with Air Traffic Control operations and the second method which uses the IFR-6000 antennas.

#### 2. Equipment and Materials

- A. Special Tools and Equipment

Name and Part Number
Transponder Test Set (Aeroflex, IFR6000) or equivalent
UC-584 Universal Transponder Antenna Coupler   Dual Antenna Kit (Viavi 112349)[1]
Weight-on-Wheels (WOW) Box (EAI, 87-117390-1001) or AMC 2.4.01 (or higher).
Ground Power Unit (GPU). AllStar 450 or AllStar G.S.E. or Hobart GPU-400 or Hobart GPU-600 or Bycan PS-28100

[1] For test with UC-584 antenna coupler.

#### 3. Job Set-Up with UC-584 Antenna Couplers

SUBTASK AMM-34-50-21-071-921-001-A

- A. Make aircraft safe for maintenance. Refer to [AMM-20-00-01-051-801 – Make Safe For Maintenance](#).
- B. If on jacks, refer to [AMM-07-10-00-051-801 – Jacking - Maintenance Practices](#) and [AMM-08-20-00-051-801 – Leveling](#).
- C. Connect external power. Refer to [AMM-24-40-00-051-801 – External Power - Maintenance Practices](#). Do not turn on START BATT and SYS BATT switches until prompted.
- D. Prepare Anti-ice system for maintenance. Refer to [AMM-20-00-03-051-801 – Prepare Anti-Ice Systems For Maintenance](#).
- E. Connect Antenna Coupler UC-584S to Aircraft upper Transponder Antenna as follows: (as applicable)

NOTE: For Transponder–1 Adjustment/Test

- (1) Place Antenna Coupler (2) over the antenna (3) , guiding antenna in to the slot on the bottom of the coupler.
- (2) Lock Antenna Coupler (2) into place by pushing lever on the side of the coupler into a down and locked position.

**NOTE:** Coupler must be tightly pressed and locked in place for Test Set to function correctly. Coupler will lock into place when the black rubber gasket is not completely depressed against the aircraft, but the Test Set will not measure functions accurately.

**CAUTION:** DO NOT CONNECT COAX CABLE TO IFR-6000 ANT PORT. DAMAGE TO EQUIPMENT WILL OCCUR.

- (3) Connect long RF coaxial cable (1) between the Antenna Coupler (2) and Test Set RF I/O Connector.

**CAUTION:** THE RF COAXIAL CABLE CAN BE A TRIPPING HAZARD. MAKE SURE TO SECURE THE CABLE. PERSONAL INJURY AND DAMAGE TO THE ANTENNAS AND TEST EQUIPMENT COULD OCCUR.

- (4) Temporarily secure the coaxial cable to the aircraft with tape. Tape can be removed after the test is completed.
- (5) Push Antenna Coupler (2) firmly against the aircraft skin until the black rubber gasket on the rim of the coupler is completely depressed tightly against the aircraft.

- F. Connect Antenna Coupler UC-584 to Aircraft lower Transponder Antenna as follows: (as applicable)

**NOTE:** For Transponder–2 Adjustment/Test

- (1) Place Antenna Coupler (2) over the antenna (4) , guiding antenna in to the slot on the bottom of the coupler.
- (2) Lock Antenna Coupler (2) into place by pushing lever on the side of the coupler into a down and locked position.

**NOTE:** Antenna Coupler must be tightly pressed and locked in place for Test Set to function correctly. Coupler will lock into place when the black rubber gasket is not completely depressed against the aircraft, but the Test Set will not measure functions accurately.

**CAUTION:** DO NOT CONNECT COAX CABLE TO IFR-6000 ANT PORT. DAMAGE TO EQUIPMENT WILL OCCUR.

- (3) Connect long RF coaxial cable (1) between the Antenna Coupler and Test Set RF I/O Connector.

**CAUTION:** THE RF COAXIAL CABLE CAN BE A TRIPPING HAZARD. MAKE SURE TO SECURE THE CABLE. PERSONAL INJURY AND DAMAGE TO THE ANTENNAS AND TEST EQUIPMENT COULD OCCUR.

- (4) Temporarily secure the coaxial cable to the aircraft with tape. Tape can be removed after the test is completed.

- (5) Push Antenna Coupler (2) firmly against the aircraft skin until the black rubber gasket on the rim of the coupler is completely depressed tightly against the aircraft.
- G. Connect Weight On Wheels (WOW) box or Aircraft Maintenance Computer (AMC) and set switches on Box to W-On-W (on-ground). Refer to [AMM-20-00-04-051-801 – Weight On Wheels \(WOW\) Box - Connect/Disconnect](#).

#### 4. **Job Set-Up with IFR-6000 Antenna**

SUBTASK AMM-34-50-21-071-921-001-B

- A. Make aircraft safe for maintenance. Refer to [AMM-20-00-01-051-801 – Make Safe For Maintenance](#).
- B. If on jacks, refer to [AMM-07-10-00-051-801 – Jacking - Maintenance Practices](#) and [AMM-08-20-00-051-801 – Leveling](#).
- C. Connect external power. Refer to [AMM-24-40-00-051-801 – External Power - Maintenance Practices](#). Do not turn on START BATT and SYS BATT switches until prompted.
- D. Prepare Anti-ice system for maintenance. Refer to [AMM-20-00-03-051-801 – Prepare Anti-Ice Systems For Maintenance](#).
- E. Take proper safety precautions to protect personnel. Position aircraft such that multi-path RF reflections between the IFR-6000 test set, the aircraft's antennas, and surrounding objects are minimized. The area on the left side of the aircraft should not be up against a metal wall or another aircraft. If necessary, position the aircraft outside, away from metal buildings or other aircraft. Refer to [Fig. 502](#).

**CAUTION:** FAILURE TO COMPLY WITH THIS STEP AND CONTINUING WITH THIS PROCEDURE COULD IMPACT LOCAL AIRPORT TOWER OPERATIONS.

- F. If applicable, contact local airport tower to inform them a transponder test is being run at your location (inside or outside). Request appropriate squawk and allotted time to run test.

**NOTE:** If local airport tower is not informed, use code 1200.

- G. Attach test set antenna to Transponder Test Set using 1 foot long test set cable (blue cable, supplied if IFR6000 is used), connected to ANT port on tester.
- H. During testing, place the Transponder Test Set antenna approximately two feet to four feet forward and in line with right wing tip tank. May require periodic repositioning between two and four feet.
- I. Connect Weight On Wheels (WOW) box or Aircraft Maintenance Computer (AMC) and set switches on Box to W-On-W (on-ground). Refer to [AMM-20-00-04-051-801 – Weight On Wheels \(WOW\) Box - Connect/Disconnect](#).

## 5. ADS-B System Test

SUBTASK AMM-34-50-21-071-701-002

- A. In order to verify ADS-B OUT function is active, perform the following test using IFR 6000 or an equivalent test set.

**NOTE:** If IFR 6000 (or an equivalent transponder test set) does not include the ADS-B test capability, at a minimum, verification that the DF17 extended squitter format is being detected is sufficient. During Generic Mode S tests, DF17 format availability is being checked in the following subtasks:

- SUBTASK AMM-34-50-20-071-C-701-001-A [SUBTASK AMM-34-50-20-071-C-701-001-A](#) or SUBTASK AMM-34-50-20-071-C-701-001-B [SUBTASK AMM-34-50-20-071-C-701-001-B](#)
- SUBTASK AMM-34-50-20-071-C-701-002-A [SUBTASK AMM-34-50-20-071-C-701-002-A](#) or SUBTASK AMM-34-50-20-071-C-701-002-B [SUBTASK AMM-34-50-20-071-C-701-002-B](#)
- SUBTASK AMM-34-50-20-071-C-701-003-A [SUBTASK AMM-34-50-20-071-C-701-003-A](#) or SUBTASK AMM-34-50-20-071-C-701-003-B [SUBTASK AMM-34-50-20-071-C-701-003-B](#)
- SUBTASK AMM-34-50-20-071-C-701-004-A [SUBTASK AMM-34-50-20-071-C-701-004-A](#) or SUBTASK AMM-34-50-20-071-C-701-004-B [SUBTASK AMM-34-50-20-071-C-701-004-B](#)

**NOTE:** If no transponder test set with the ADS-B test capability is available, as an additional or alternate method of verifying proper operation and performance of the installed ADS-B OUT function, the FAA Public ADS-B Performance Report (PAPR) may be requested after a Return to Service (RTS) flight. This report request may be made online on the FAA web site at the ADS-B related area.

**NOTE:** To check if IFR 6000 has the ADS-B test, press SETUP to display SETUP-GENERAL page. Press INFO and verify that ADSB is listed in the OPTIONS area.

If using IFR 6000 with the ADSB test option, to make sure that the ADS-B OUT function is active, perform the following procedure:

### (1) ADS-B Test Setup

- (a) After the Transponder Test Set (IFR 6000) performs Self Test, push SETUP button on the test set to bring up the SETUP-XPDR page. If necessary, continue pressing SETUP button until SETUP XPDR screen is displayed.
- (b) Press ADS-B SETUP Soft Key to display the SETUP-ADSB Setup Screen. Use NEXT PARAM and PREV PARAM Soft Keys to select each parameter. Configure the setup parameters as shown in the following example:  
POS DECODE: GLOBAL  
LAT: 35 02 13.80 N  
LON: 106 37 1.80 W  
BARO PRES ALT: 5450 ft.

## ADSB MON: DF17

**NOTE:** LAT and LON must be set to the values corresponding to the location of the test as shown on the MFD GPS Status Page. In this example, for the test set entry, the position data corresponds to the MFD displayed position data of N35°02.23' W106°37.03', where seconds are represented as a fraction of a minute, and, therefore, the entered seconds' values are  $0.23 \times 60 \text{ sec} = 13.80 \text{ sec}$  and  $0.03 \times 60 \text{ sec} = 1.80 \text{ sec}$ , respectively. BARO PRES ALT is a test reference and must be set to the value corresponding to the tested aircraft Pressure Altitude. Therefore, using the Autopilot Control Panel (ACP) controls, set Baro Correction to 29.92 inHg, and then enter the altitude value displayed on the PFD into BARO PRES ALT entry field of IFR 6000. This entry may not be available in some IFR 6000 test sets.

## (2) ADS-B OUT Data Monitor Test

- (a) Make sure aircraft power is off.
- (b) Set WOW Box switches to W-on-W (on-ground).
- (c) On IFR 6000, press XPDR mode Key until ADSB/GICB/UAT MAIN menu is displayed. Press the ADS-B MON Soft Key to display the ADS-B MON list screen.
- (d) Power up the aircraft.
- (e) On the PFD, select active transponder and enter transponder test squawk code as 1200 (or if using the Job Set-Up with IFR-6000 Antenna – as assigned by the Air Traffic Control).
- (f) Make sure that the Baro Correction is set to 29.92 inHg.
- (g) Set WOW Box switches to W-off-W (airborne). Transponder should be in ALT mode.
- (h) Select BDS 0,5 AIRBORNE POS and check the following data:
  - AA = matches aircraft ICAO code displayed on the MFD Settings Page
  - LAT = comparable to the aircraft latitude.
  - LON = comparable to the aircraft longitude.
  - BARO PRES ALT = matches aircraft altitude displayed on the L PFD within 125 ft.
- (i) Set WOW Box switches to W-on-W (on-ground).

## 6. Job Close-Up

SUBTASK AMM-34-50-21-071-921-003

- A. Reset the collared ECB's. Refer to AMM-20-00-03-051-801 – Prepare Anti-Ice Systems For Maintenance.
- B. Scroll to FLCS using outer knob. Press inner knob to select. Scroll to the listed ECB using outer knob and highlight. Push “RESET” Soft key. Press “CONFIRM RESET” soft key.
  - ECB - NOSE LDG GEAR (L AFT Bus)
  - ECB - L MAIN LDG GEAR (L AFT Bus)
  - ECB - R MAIN LDG GEAR (L AFT Bus)
- C. Scroll to ENGINE using outer knob. Press inner knob to select. Scroll to the listed ECB using outer knob and highlight. Push “RESET” Soft key. Press “CONFIRM RESET” soft key.
  - ECB - L ENG FIRE EXTNGR (L FWD Bus)
  - ECB - R ENG FIRE EXTNGR (R FWD Bus)
- D. Power down the aircraft by setting the SYS BATT and START BATT switches to OFF and the BUS TIE to OPEN.
- E. Disconnect WOW Box from aircraft. Refer to AMM-20-00-04-051-801 – Weight On Wheels (WOW) Box - Connect/Disconnect.
- F. If on jacks, lower aircraft and remove jacks. Refer to [AMM-07-10-00-051-801 – Jacking - Maintenance Practices](#).
- G. If applicable, call the local control tower and tell them the transponder test is complete.
- H. Remove all tools, equipment and unwanted material from work area.
- I. Disconnect external power. Refer to [AMM-24-40-00-051-801 – External Power - Maintenance Practices](#).
- J. If all other maintenance is complete, return aircraft to service. Refer to [AMM-20-00-02-051-801 – Return To Service \(After Maintenance\)](#).

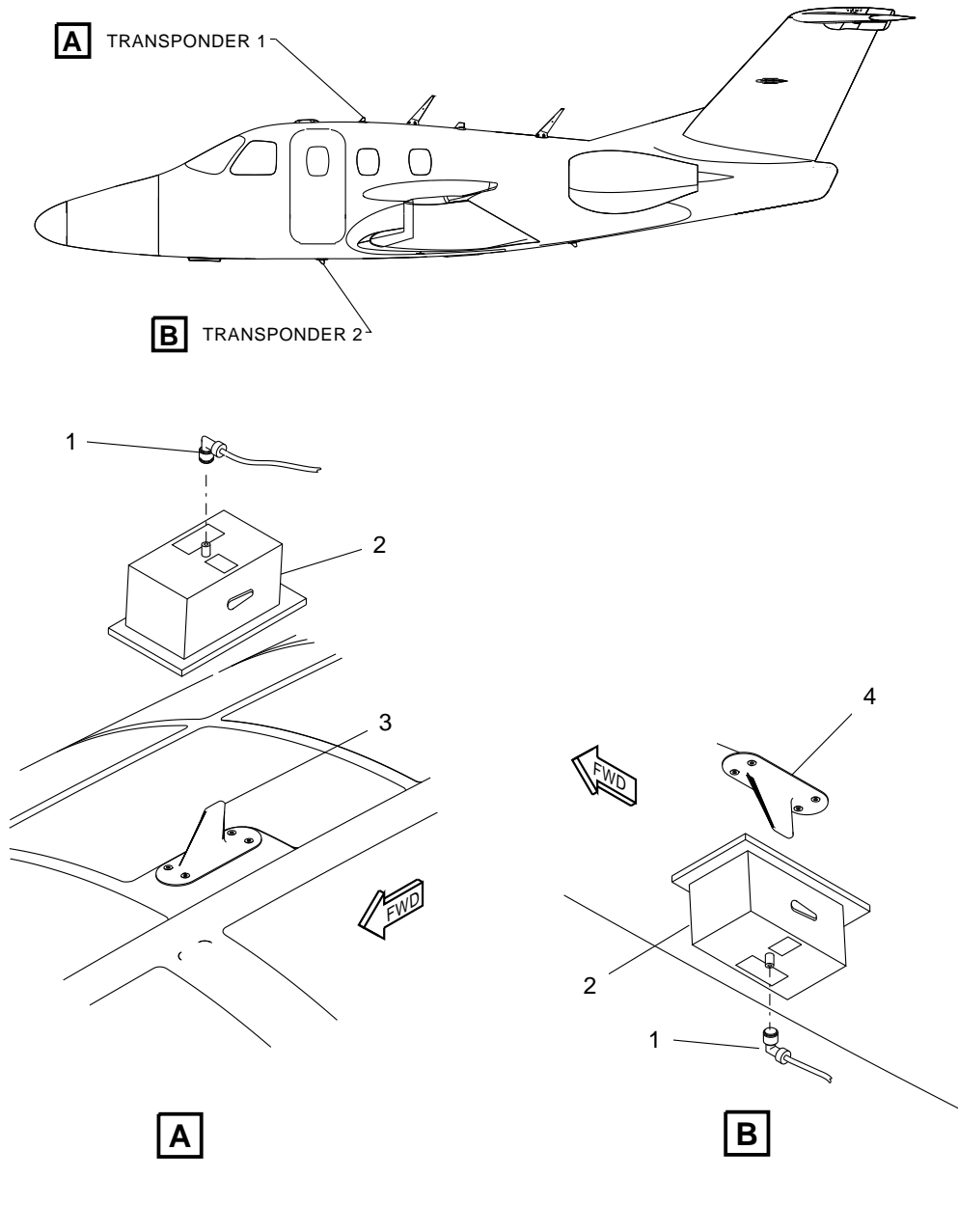

**Transponder - Adjustment/Test**  
**Figure 501 (Sheet 1 of 1)**

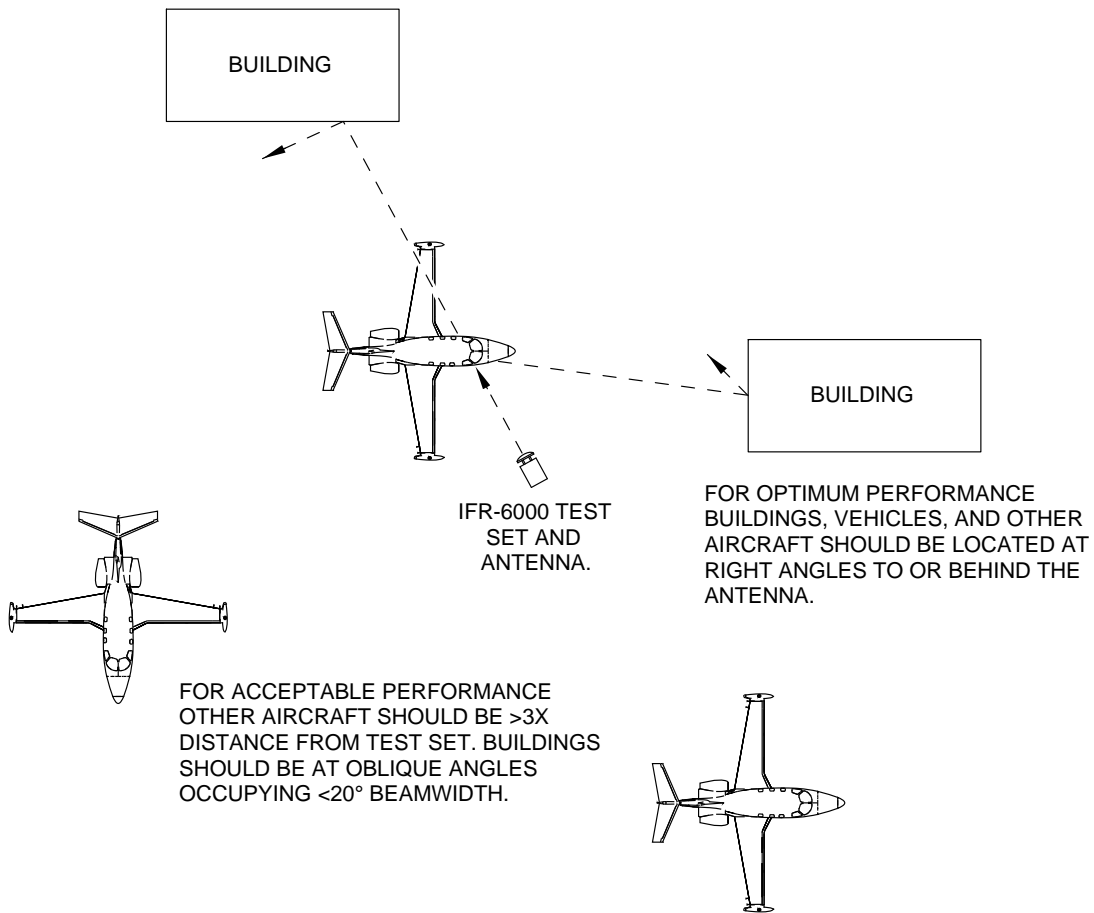
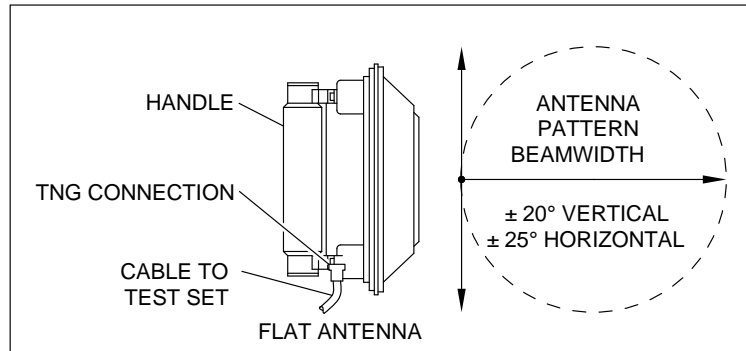

5081043A

**ADS-B - Adjustment/Test  
Figure 502 (Sheet 1 of 1)**

---

## **TRANSPONDER - INSTALLATION**

AMM-34-50-21-041-801

### **1. General**

- A. This task gives the procedures to install the transponder.
- B. There are two transponders, one is behind the left PFD and the other is behind the right PFD. The installation procedure is given for the left transponder and is the same for the right transponder.
- C. If the aircraft has ADS-B OUT function, ensure this transponder has Extended Capability (ES) enabled and software version is at 8.02 or above.

**NOTE:** Make sure that the transponder software is in same configuration as it was when the removal task was completed. If necessary, update transponder software to the required level.

### **2. Job Set-Up**

SUBTASK AMM-34-50-21-041-921-001

- A. Make sure that the aircraft is in same configuration as it was when the removal task was completed. Refer to [AMM-34-50-21-001-801 – Transponder - Removal](#).
- B. As required, make sure that transponder is configured for ADS-B. Refer to [AMM-34-50-20-051-801 – Transponder with ADS-B Out – Maintenance Practices](#).

### **3. Procedure**

SUBTASK AMM-34-50-21-041-411-001

(Refer to [Fig. 401](#) .

- A. Loosen the captive screw (2) and rotate the lever (3) to the open position on the transponder.
- B. Slide the transponder (1) into the mount (4) . Rotate the lever (3) to the closed position and tighten the screw (2) .
- C. Electrically bond the transponder (1) to the structure. Refer to [AMM-20-03-00-051-801 – Electrical Bonding - Maintenance Practices](#). Resistance must be 2.5 milliohms or less.

#### 4. **Job Close-Up**

SUBTASK AMM-34-50-21-041-921-002

- A. Remove all tools, equipment, and unwanted material from the work area.
- B. Install the following:  
Refer to [AMM-31-10-16-041-801 – Primary Flight Display - Installation](#).
  - 221 PZ - Left Primary Flight Display (PFD).
  - 222 JZ - Right Primary Flight Display (PFD).
- C. Remove the warning placard.
- D. Do an adjustment/test of the transponder system. Refer to [AMM-34-50-20-071-C-801 – Transponder - Adjustment/Test](#).
- E. If all other maintenance is complete, return the aircraft to service. Refer to [AMM-20-00-02-051-801 – Return To Service \(After Maintenance\)](#).

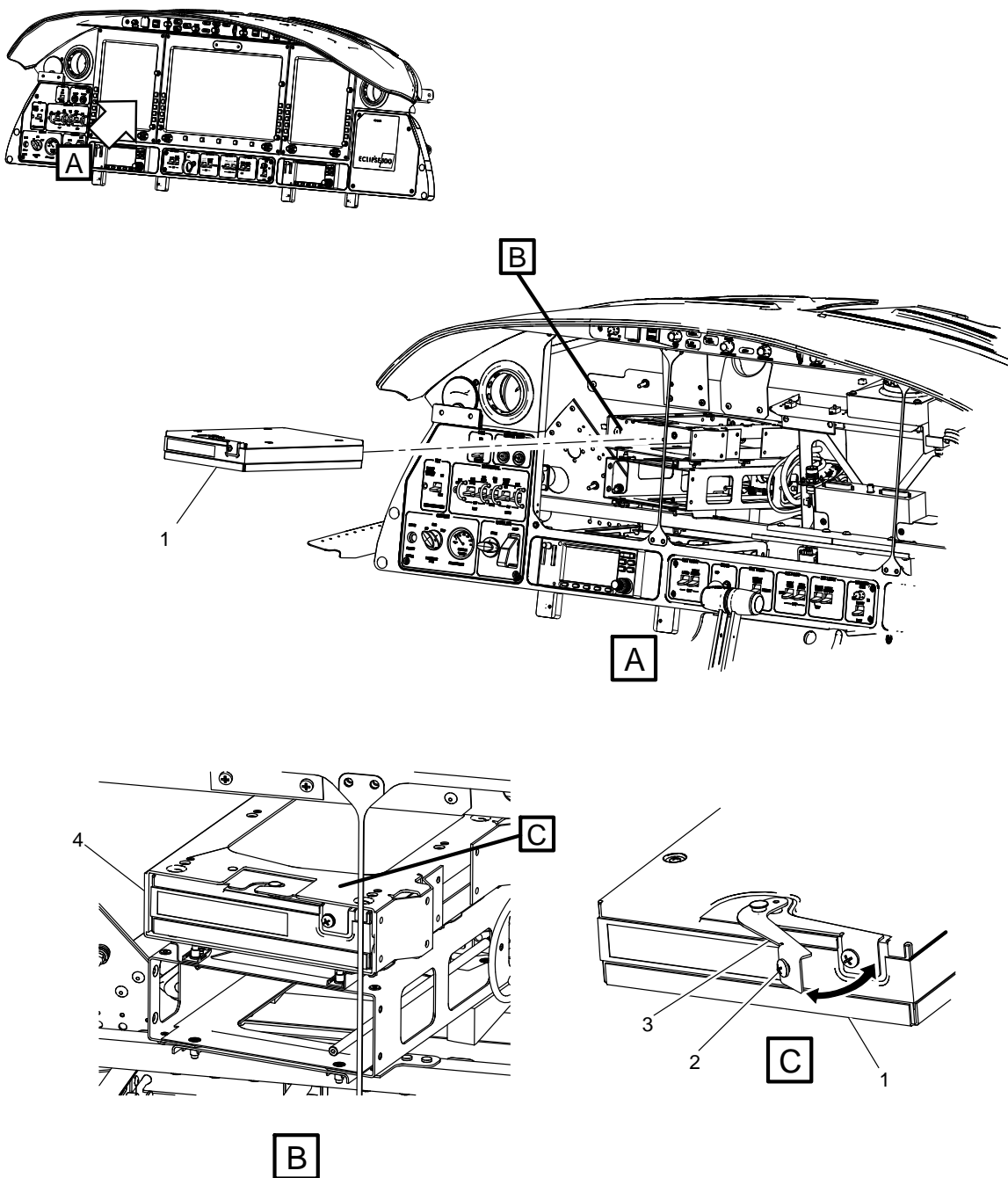

**NOTE:**  
STRUCTURE AND EQUIPMENT  
REMOVED FOR CLARITY

5080776A

**Transponder - Removal/Installation (Avio NG +1.5 display shown)  
Figure 401 (Sheet 1 of 1)**

THIS PAGE INTENTIONALLY LEFT BLANK

---

## TRANSPONDER ANTENNA RELAY - INSTALLATION

AMM-34-50-23-041-801

### **1. General**

- A. This task gives the procedures to install the transponder antenna relay(s).
  - (1) Single Diversity Transponder Configuration:
    - (a) There is one transponder lower antenna relay installed with the optional Single Diversity Transponder configuration behind the instrument panel.
  - (2) Dual Diversity Transponder Configuration
    - (a) There are two transponder (upper and lower) antenna relays installed with the optional Dual Diversity Transponder configuration behind the instrument panel.

### **2. Job Set-Up**

SUBTASK AMM-34-50-23-041-921-001

- A. Make sure the aircraft is in the same configuration as it was when the removal task was completed. Refer to [AMM-34-50-23-001-801 – Transponder Antenna Relay - Removal](#).

### **3. Procedure**

SUBTASK AMM-34-50-23-041-411-001

(Refer to [Fig. 401](#). Installation procedures apply to both sides)

**NOTE:** The lower antenna relay (and upper antenna relay if a second diversity transponder is installed) are located inboard of their respective diversity transponder(s).

- A. Remove the protective caps from the electrical connectors.
- B. Put the transponder lower and/or (if installed) upper antenna relay (1) on the structure and align the holes.
- C. Attach the transponder lower and/or (if installed) upper antenna relay (1) with the two screws (3) and washers (2).
- D. Connect the coax cable connectors 23K02P01 to the transponder lower antenna relay coax receptacle marked COM (Common) (5).
- E. If transponder upper antenna relay installed, connect the coax cable connectors 23K03P01 to the transponder upper antenna relay coax receptacle marked COM (Common) (5).
- F. Connect the coax cable connectors 23K02P02 to the transponder lower antenna relay coax receptacle marked NC (Normally Closed) (6).
- G. If transponder upper antenna relay installed, connect the coax cable connectors 23K03P02 to the transponder upper antenna relay coax receptacle marked NC (Normally Closed) (6).

- H. Connect the coax cable connectors 23K02P03 to the transponder lower antenna relay coax receptacle marked NO (Normally Open) (4) .
- I. If transponder upper antenna relay installed, connect the coax cable connectors 23K03P03 to the transponder upper antenna relay coax receptacle marked NO (Normally Open) (4) .
- J. Connect the electrical connector 23K02P04 to the transponder lower antenna relay electrical receptacle (7) .
- K. If transponder upper antenna relay installed, connect the electrical connector 23K03P04 to the transponder upper antenna relay electrical receptacle (7) .
- L. Electrically bond the transponder lower antenna relay (1) to the structure. Refer to [AMM-20-03-00-051-801 – Electrical Bonding - Maintenance Practices](#). Resistance must be 2.5 milliohms or less.

#### 4. **Job Close-Up**

SUBTASK AMM-34-50-23-041-921-002

- A. Remove all tools, equipment, and unwanted material from the work area.
- B. If removed, install the air conditioning ducts. Refer to [AMM-21-20-11-041-801 – Cockpit Ducting - Installation](#).
- C. Install the 222 KZ - Multi Function Display (MFD). Refer to [AMM-31-10-15-041-801 – Multi-Function Display - Installation](#).
- D. Remove the warning placards.
- E. Do the adjustment/test of the transponder system. Noting effectivity, refer to [AMM-34-50-20-071-801 – Transponder - Adjustment/Test](#)
- F. If all other maintenance is complete, return the aircraft to service. Refer to [AMM-20-00-02-051-801 – Return To Service \(After Maintenance\)](#).

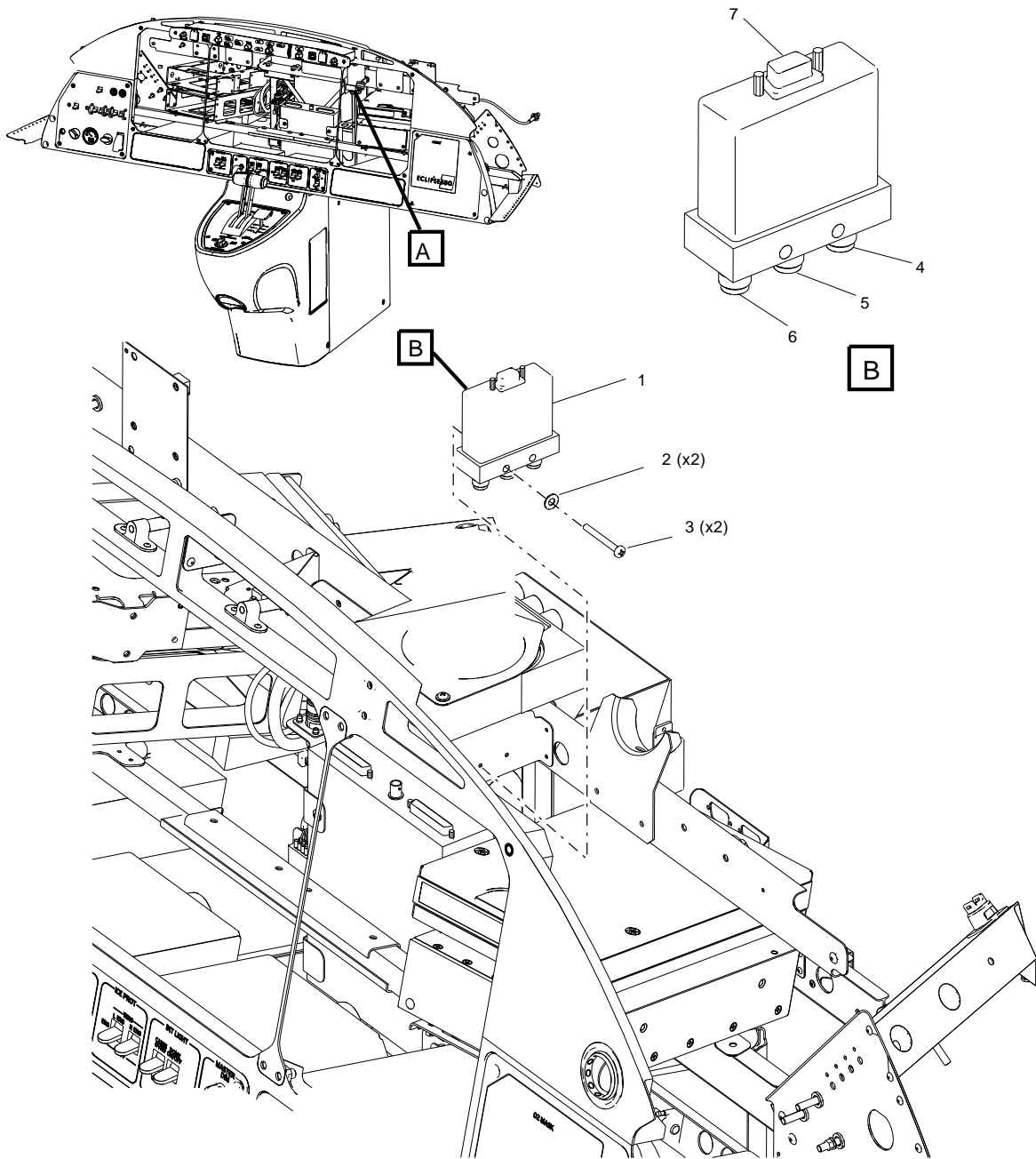

**NOTE:**  
STRUCTURE AND EQUIPMENT  
REMOVED FOR CLARITY

**A**

508077B

**Transponder Antenna Relay - Removal/Installation (Avio NG +1.5 Display shown)  
Figure 401 (Sheet 1 of 1)**

THIS PAGE INTENTIONALLY LEFT BLANK

### ADS-B FAIL INDICATOR - REMOVAL

AMM-34-50-26-001-801

#### 1. General

- A. This task gives procedures to remove the ADS-B Fail Indicator.
- B. There is one ADS-B Fail Indicator installed on the lower left instrument panel.

#### 2. Equipment and Materials

**Table 401. Special Tools and Equipment**

Name & Part Number
Extraction Tool (Aerospace Optics 18–234)
Cap Extractor Tool (Aerospace Optics 17–150)

#### 3. Job Set-Up

SUBTASK AMM-34-50-26-001-921-001

- A. Make aircraft safe for maintenance. Refer to [AMM-20-00-01-051-801 – Make Safe For Maintenance](#).
- B. Make sure all power is removed from the aircraft.

#### 4. Procedure

SUBTASK AMM-34-50-26-001-011-001

(Refer to [Fig. 401](#).)

- A. Remove the ADS-B Fail Indicator as follows:
  - (1) Remove two screws (2) that secure bracket (1) to the Instrument panel.
  - (2) Disconnect electrical connector (3) from switch body (6) with extraction tool 18–234.
  - (3) Identify the two extraction slots positioned on either side of the cap (7). Extract the switch cap (7) by using the Cap Extractor Tool (Part Number: 17-150) or by applying finger pressure on two sides of the switch cap pulling the switch cap from the switch body.
  - (4) Remove switch cap (7) from the switch body (6) by gently removing the cap pins from the hinged slide retainer.
  - (5) From the front of the switch body (6) locate the two slot head integral mounting screws (8) in the base of the body. Loosen the two screws until the Integral Mounting Hardware releases the mounting sleeve from the mounting panel.
  - (6) From behind the bracket (1), remove the locking sleeve (4) and spacer (5) from the switch body by sliding aft from the bracket (1).

| (7) Remove switch body (6) from the bracket (1) .

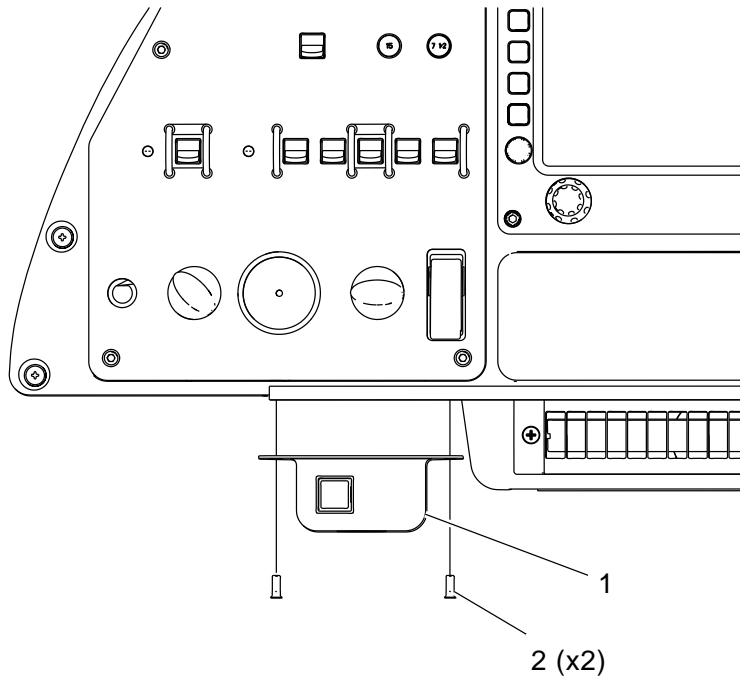
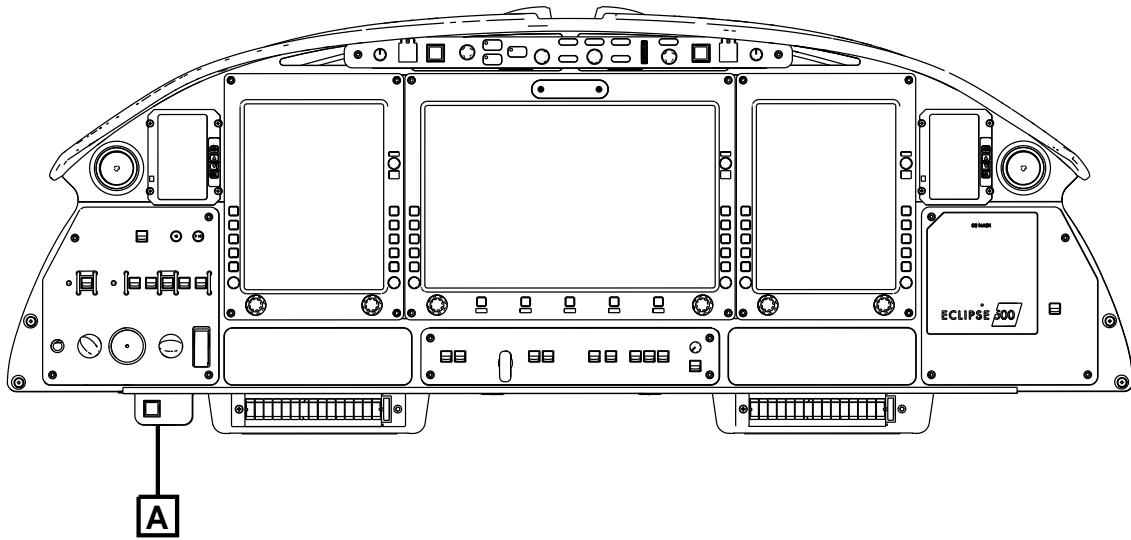

5181987A

**ADS-B Fail Indicator - Removal/Installation**  
**Figure 401 (Sheet 1 of 2)**

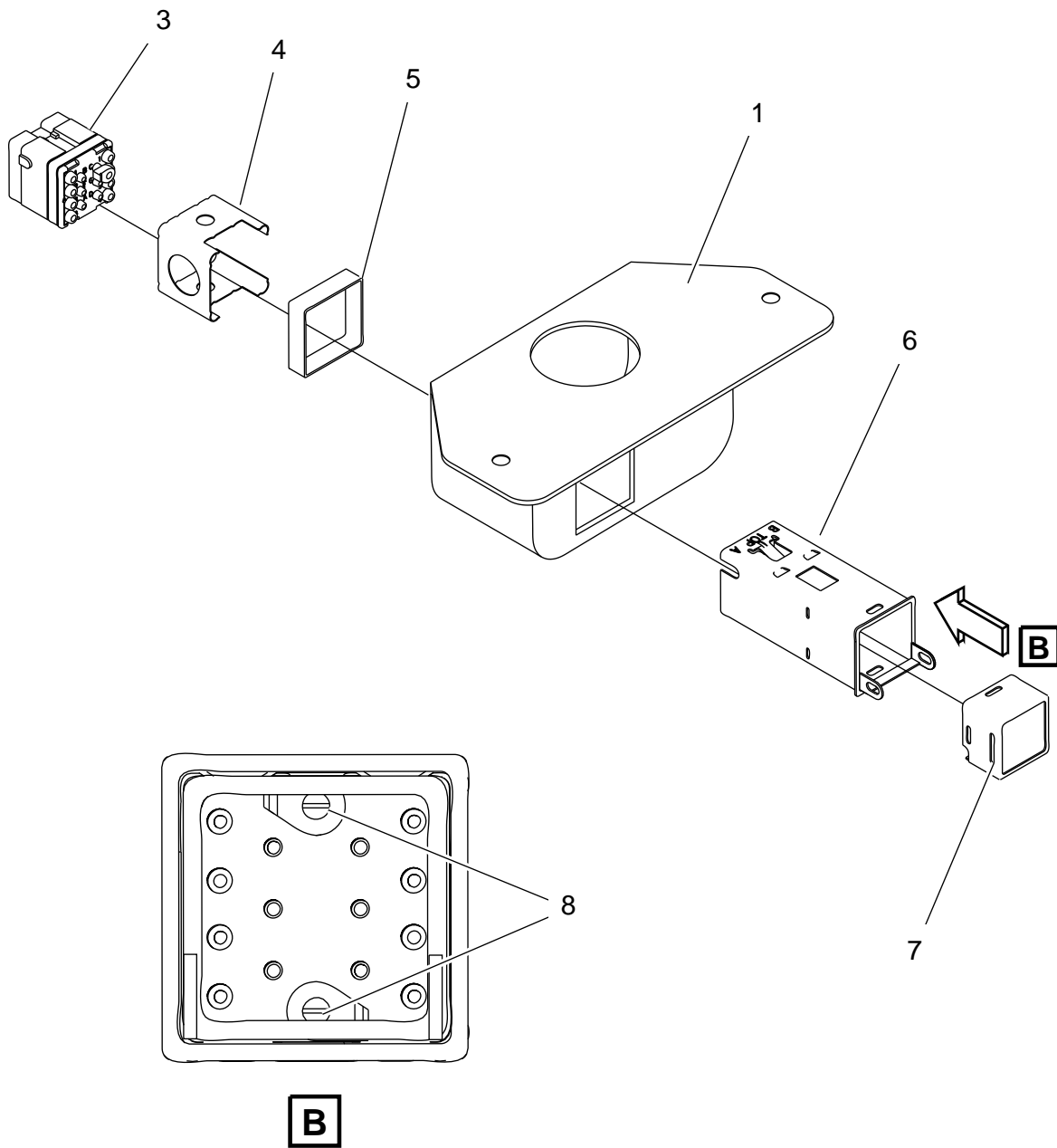

5181986A

**ADS-B Fail Indicator - Removal/Installation**  
**Figure 401 (Sheet 2 of 2)**

---

## **ADS-B FAIL INDICATOR - INSTALLATION**

AMM-34-50-26-041-801

### **1. General**

- A. This task gives procedures to install the ADS-B Fail Indicator.
- B. There is one ADS-B Fail Indicator installed on the lower left instrument panel.

### **2. Job Set-Up**

SUBTASK AMM-34-50-26-041-921-1

- A. Make sure the aircraft and Fail Indicator (disassembled) are in the same configuration as it was when the removal task was completed. Refer to [AMM-34-50-26-001-801 – ADS-B Fail Indicator - Removal](#)

### **3. Procedure**

SUBTASK AMM-34-50-26-041-411-1

(Refer to [Fig. 401.](#))

- A. Install the ADS-B Fail Indicator as follows:
  - (1) Insert the back of the switch body (6) into the mounting bracket (1) by sliding it through the bracket (1) from the front. Ensure the switch body label "TOP" is positioned up.
  - (2) From behind the mounting bracket (1), place the locking sleeve (4) onto the switch body (6) and sliding it forward against the mounting bracket (1).
  - (3) From the front of the switch body (6) locate the two slot head integral mounting screws (8) in the base of the body. Tighten the two screws (8) until the Integral Mounting Hardware pulls the mounting sleeve (4) against the mounting bracket (1). Torque screws to 18-25 ounce.in.
  - (4) Replace the switch cap (7) by inserting the cap pins into the slide retainer (6) and push the cap (7) into the switch body (6).
  - (5) Align keyways and push electrical connector (3) on to the back of the switch body (6) until it clicks.
- B. Position bracket (1) with assembled ADS-B Fail Indicator on to the left lower instrument panel and align screw holes.
- C. Attach bracket (1) with ADS-B Fail Indicator with two screws (2). Torque screws (2) to 18-23 lbf.in.

**4. Job Close-Up**

SUBTASK AMM-34-50-26-041-921-002

- A. Remove all tools, equipment, and unwanted material from the work area.
- B. Do ADS-B FAIL Indicator Functional Test. Refer to [SUBTASK AMM-34-50-20-071-C-701-008](#).
- C. If all other maintenance is complete, return the aircraft to service. Refer to [AMM-20-00-02-051-801 – Return To Service \(After Maintenance\)](#).

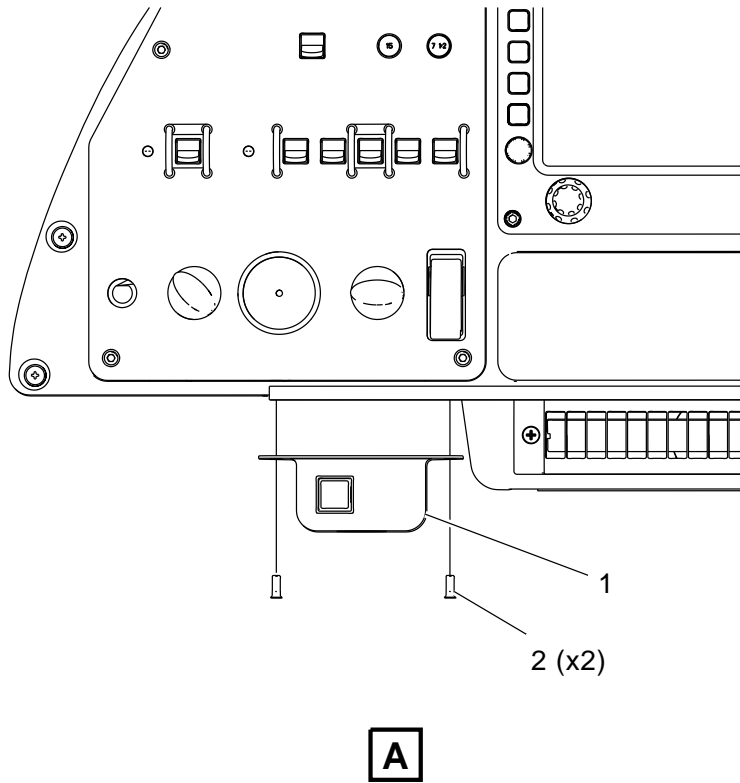
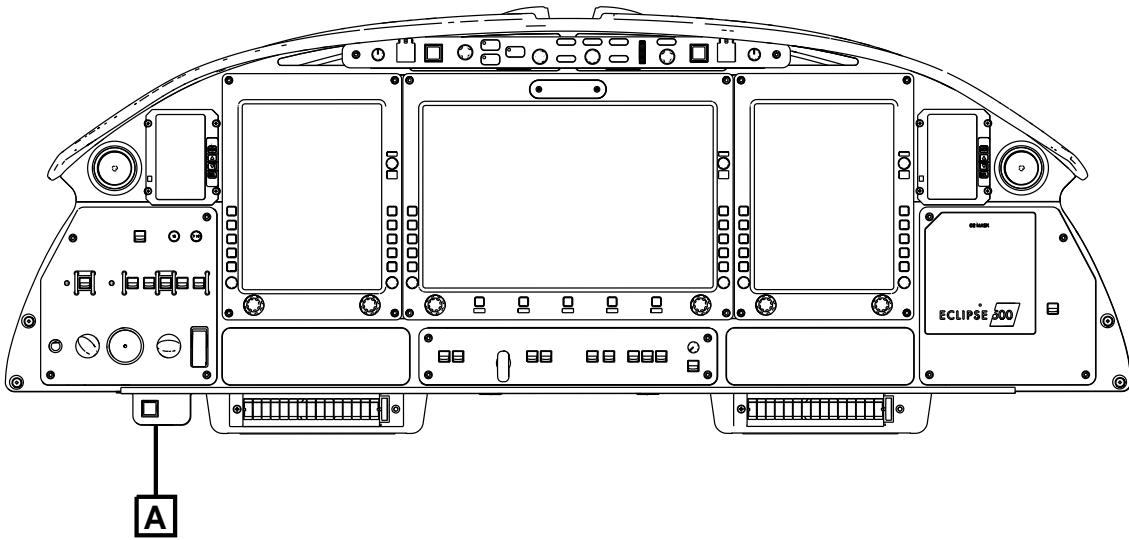

**ADS-B Fail Indicator - Removal/Installation**  
**Figure 401 (Sheet 1 of 2)**

5181987A

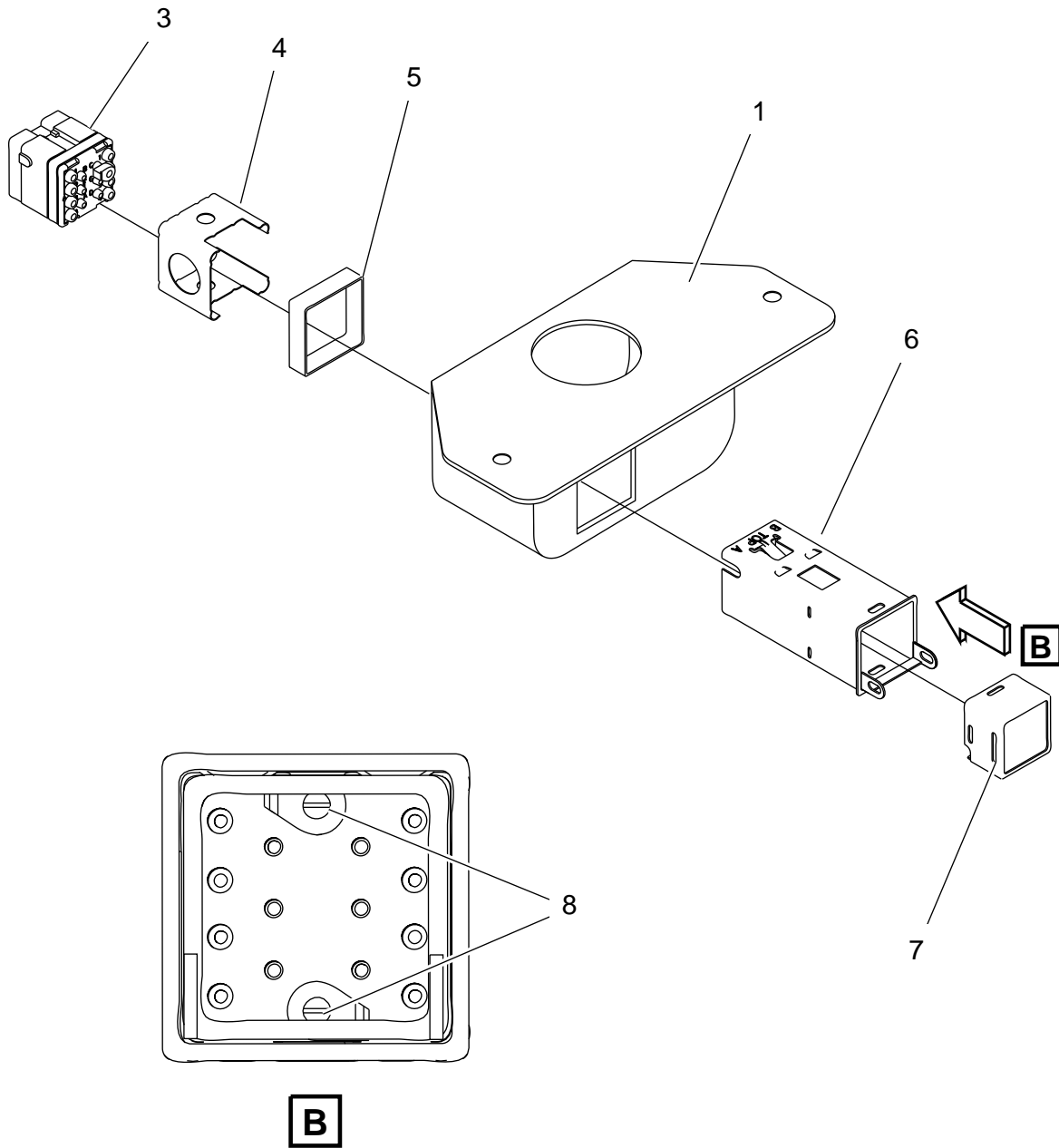

5181986A

**ADS-B Fail Indicator - Removal/Installation**  
**Figure 401 (Sheet 2 of 2)**