

## CHAPTER 34 – HIGHLIGHTS

*Revision No. TR34-4 September 26/19*

TO: HOLDERS OF THE WIRING DIAGRAM MANUAL (06-117753)

Pages that have been added or revised are summarized below. Remove and insert the affected pages as listed, and enter the above revision number with issue date into the Record of Revisions sheet.

**TR34-4 supersedes TR34-3.**

*Do not remove this page. Keep it in place as a record of previous changes.*

CH/SE/SU	Description of Change
34-50-20	Chapter 34, "Navigation Systems," has an optional set of ADS-B Upgrade diagram pages. These pages apply only if the ADS-B Upgrade has been installed to the aircraft  Figure 1 shows the in-line attenuating resistor to the ADS-B Fail Indicator. POST MB 500-34-030  Figure 2 shows the in-line attenuating resistor to the ADS-B Fail Indicator removed. POST MB 500-34-031.

*[Intentionally Blank Page]*

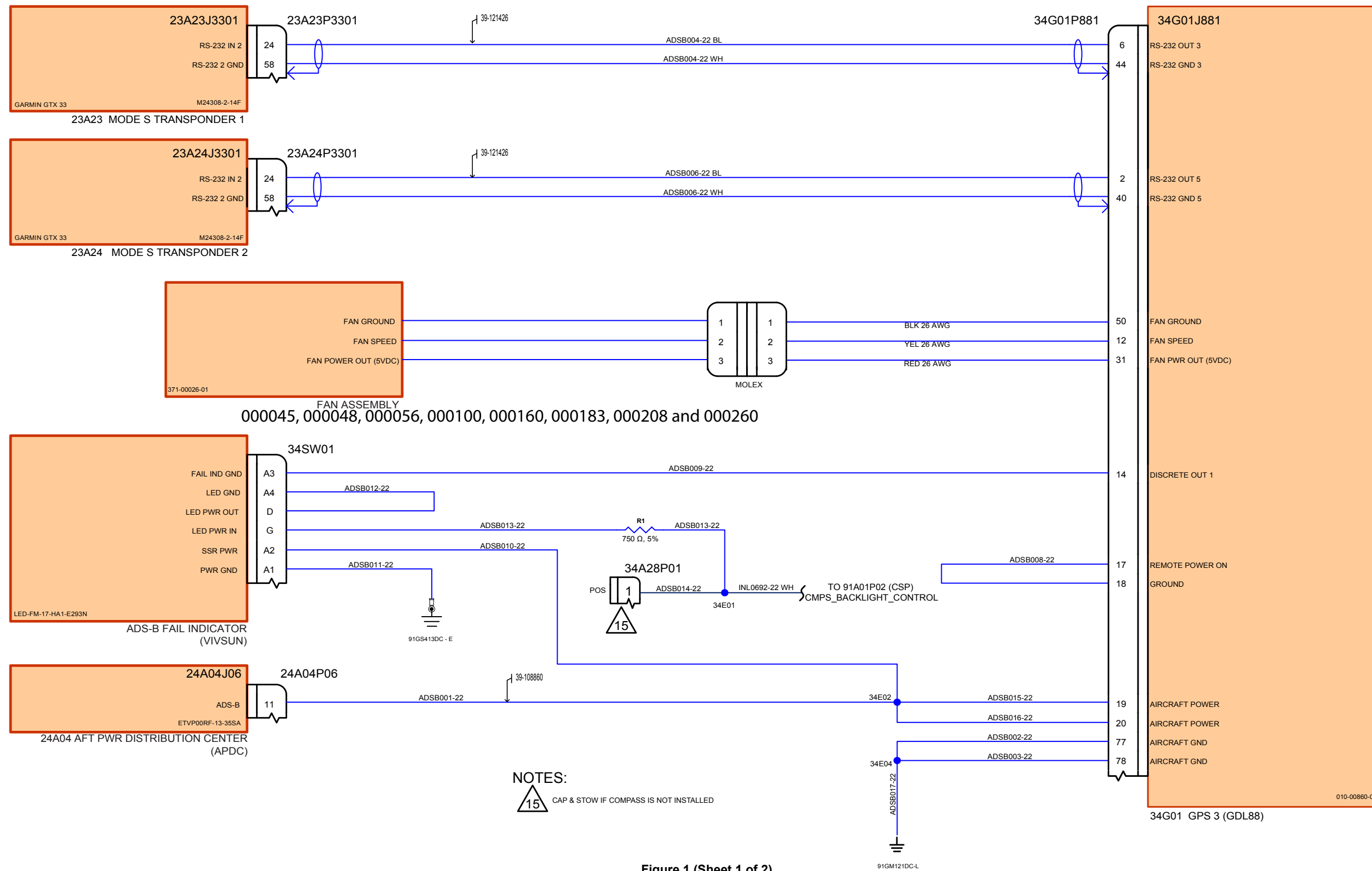

Figure 1 (Sheet 1 of 2)

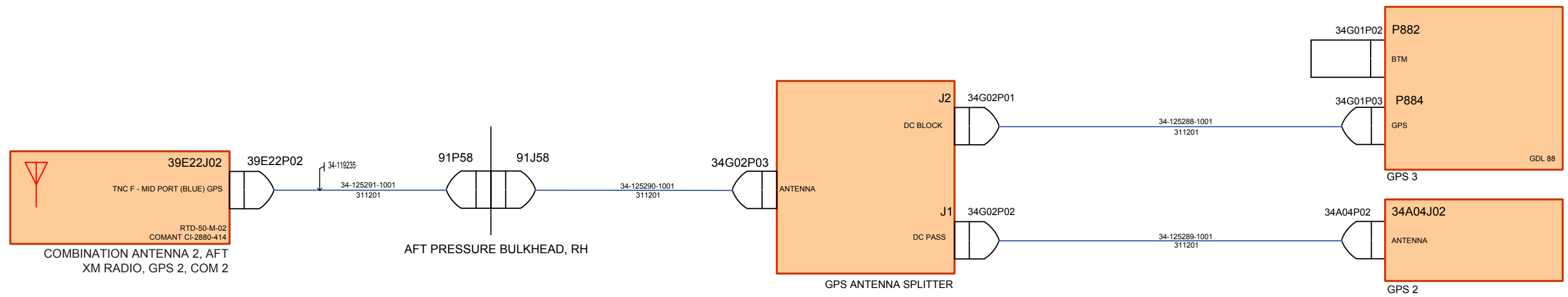

Figure 1 (Sheet 2 of 2)

34-125260-1001A-3

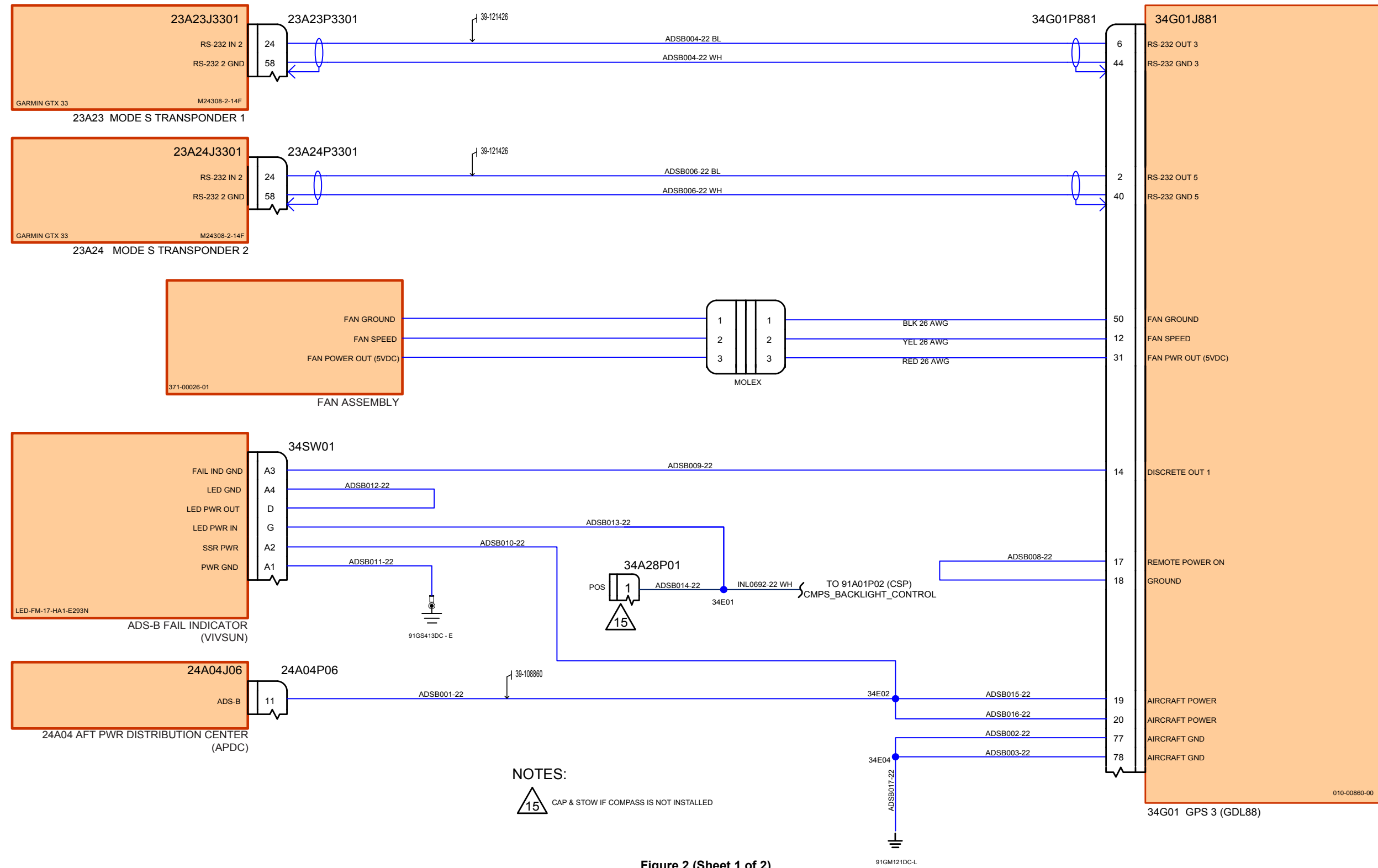

Figure 2 (Sheet 1 of 2)

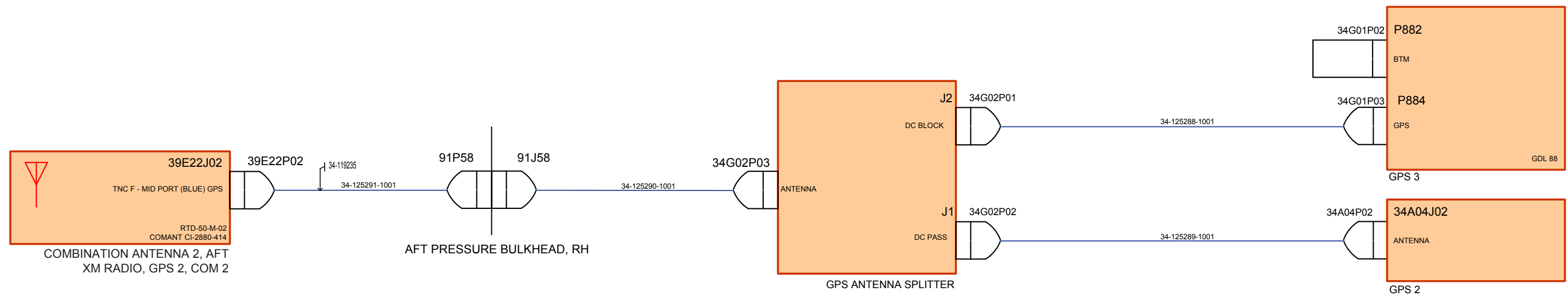

Figure 2 (Sheet 2 of 2)

34-125260-1002B-3