CHAPTER - 34 HIGHLIGHTS
(Summary of Changes)*Revision No. TR34-8 Aug 22/18*

TO: HOLDERS OF THE AIRCRAFT MAINTENANCE MANUAL (06-123838)

Pages that have been added or revised are summarized below. Remove and insert the affected pages as listed, and enter the above revision number with issue date into the Record of Revisions sheet.

This Temporary Revision incorporates and supersedes previously released temporary revisions for the chapters listed below.

Do not remove this page. Keep it in place as a record of previous changes.

CH/SE/SU Page Block No.	Description of Change
34-10-00 PgBlk 501	Corrected Standby Pitot/Static Probe Verification Test, SUBTASK AMM-34-10-00-071-701-006 for SDU.

THIS PAGE INTENTIONALLY LEFT BLANK

FLIGHT ENVIRONMENT DATA - ADJUSTMENT/TEST

AMM-34-10-00-071-801

1. General

- A. This task gives procedures to do an adjustment/test of the flight environment data components.

NOTE: This test procedure complies with the requirements of 14 CFR Part 43 Appendix E.

- (1) Unless indicated differently, the adjustment/test procedures are the same for both left and right sides.
- (2) Included are procedures for use of both the Barfield Pitot/Static Tester (Barfield, DPS450) and the Barfield Pitot/Static Tester (Barfield, DPS500).
- (3) After a replacement of the left and right Pitot/AOA probes, static ports, Air Data Computers (ADCs), Standby Pitot/Static probe and Outside Air Temperature (OAT) probes, do the test for each component shown in the table below.

Table 501. Component Test Matrix

Component to be Tested	Test
Left and right ADCs	<i>Pitot and Static System Leak Test</i> SUBTASK AMM-34-10-00-071-701-001 , <i>Pitot and Static Verification Test</i> SUBTASK AMM-34-10-00-071-701-005 and <i>Angle of Attack Test</i> SUBTASK AMM-34-10-00-071-701-004 and AMM-24-00-00-071-801 – Electrical Power - Adjustment/Test , SUBTASK AMM-24-00-00-071-701-005 , Left and Right ADC Test. If software only is replaced, perform the following: <i>Pitot and Static Verification Test</i> SUBTASK AMM-34-10-00-071-701-005 .
Left and right Pitot/AOA probes	<i>Pitot and Static System Leak Test</i> SUBTASK AMM-34-10-00-071-701-001 , <i>Angle of Attack Test</i> SUBTASK AMM-34-10-00-071-701-004 and AMM-30-30-00-071-801 – Pitot and Static Anti-Ice System - Adjustment/Test . If software only is replaced, perform the following: <i>Pitot and Static System Leak Test</i> SUBTASK AMM-34-10-00-071-701-001 , and <i>Angle of Attack Test</i> SUBTASK AMM-34-10-00-071-701-004 .
Left and right Static ports	<i>Pitot and Static System Leak Test</i> SUBTASK AMM-34-10-00-071-701-001 and AMM-30-30-00-071-801 – Pitot and Static Anti-Ice System - Adjustment/Test .

EFFECTIVITY: ALL

34-10-00

Component to be Tested	Test
Standby Pitot/Static probe	<i>Standby Pitot/Static Probe System Leak Test</i> SUBTASK AMM-34-10-00-071-701-002 , <i>Standby Pitot/Static Probe Verification Test</i> SUBTASK AMM-34-10-00-071-701-006 and AMM-30-30-00-071-801 – Pitot and Static Anti-Ice System - Adjustment/Test . If software only is replaced, perform the following: <i>Standby Pitot/Static Probe Verification Test</i> SUBTASK AMM-34-10-00-071-701-006 .
Right and left OAT probes	<i>Outside Air Temperature Test</i> SUBTASK AMM-34-10-00-071-701-007 .

2. Equipment and Materials

Table 502. Special Tools and Equipment

Name and Part Number
Barfield Pitot/Static Tester (Barfield, DPS450) or Barfield Pitot/Static Tester (Barfield, DPS500) or Equivalent Tester.
Air Data Accessories Kit (NavAids P/N ADA500MD-945) (or) Air Data Accessories Kit ; (Nav Aids PN ADA500945) (Note: If using ADA500–945, covering pitot probes with tape is required)
Stop Watch (Inotek, EH365528) or Equivalent (Note: Calibrated with 1 second resolution)
Weight-on-Wheels (WOW) Box (EAI, 87-117390-1001).
Vinyl Tape (To cover drain hole on Pitot probes)
Ground Power Unit (GPU). AllStar 450 or AllStar G.S.E. or Hobart GPU-400 or Hobart GPU-600 or Bycan PS-28100 (Note: 28.0 ± 0.5 VDC)

3. Job Set-Up

SUBTASK AMM-34-10-00-071-921-001

- A. Make aircraft safe for maintenance. Refer to [AMM-20-00-01-051-801 – Make Safe For Maintenance](#).
- B. Apply external power to the aircraft. Refer to [AMM-24-40-00-051-801 – External Power - Maintenance Practices](#).

CAUTION: IF TRANSPONDER(S) NOT SET TO “STBY”, THE AIRCRAFT WILL CAUSE NUISANCE TRANSPONDER TRANSMISSIONS TO THE LOCAL AIRFIELD AND OTHER AIRCRAFT.

- D. When performing tests with the Weight On Wheels (WOW) box, refer to [AMM-20-00-04-051-801 – Weight On Wheels \(WOW\) Box - Connect/Disconnect](#).
 - (1) Set both the left and right PFD Baro to 29.92 by pressing the BARO SET knob on the Autopilot Control Panel (ACP). Make sure the baro setting matches on the left and right PFD.
 - (2) Collar the following ECBs:

WARNING: BECAUSE THIS TEST IS PERFORMED WITH WOFFW, THE HEATERS WILL BE COMMANDED ON BY THE SYSTEM. IF THE PITOT/STATIC HEAT ECBs ARE NOT COLLARED OFF, HARM TO PERSONNEL OR DAMAGE TO AIR DATA TEST EQUIPMENT CAN OCCUR.

NOTE: ECBs can only be collared in the Weight-on-Wheels condition.

- (4) Collar the following ECB's:
 - ECB - WEATHER RADAR (L FWD Bus)
 - ECB - DEICE MANIFOLD HTR (R AFT Bus)
 - ECB - L PITOT HEAT (L FWD Bus) or ECB - L PITOT HEAT (BATT Bus)
 - ECB - R PITOT HEAT (R FWD Bus)
 - ECB - L STATIC HEAT (BATT Bus)
 - ECB - L STATIC HEAT (R FWD Bus)
 - ECB - R STATIC HEAT (R FWD Bus)
 - ECB - R STATIC HEAT (L FWD Bus)
 - ECB - STBY PITOT HEAT (BATT Bus) or ECB - STBY PITOT HEAT (L FWD)
 - ECB - L WINDSHIELD HEAT (L AFT Bus)
 - ECB - R WINDSHIELD HEAT (R AFT Bus)
- (5) Make sure that the ADC selection source is not displayed on the left PFD. Make sure that the ADC selection source is not displayed on the right PFD.

- (6) Set both the left and right PFD Baro to 29.92 by pressing the BARO SET knob on the Autopilot Control Panel (ACP). Make sure the baro setting matches on the left and right PFD.
- (7) Make sure that the ADC 3 is displayed on the MFD ADI.

CAUTION: IF TRANSPONDER(S) NOT SET TO “STBY”, THE AIRCRAFT WILL CAUSE NUISANCE TRANSPONDER TRANSMISSIONS TO THE LOCAL AIRFIELD AND OTHER AIRCRAFT.

4. Pitot and Static System Leak Test

SUBTASK AMM-34-10-00-071-701-001

CAUTION: DO NOT PRESSURIZE THE AIRCRAFT DURING TESTING.

NOTE: If a Barfield Pitot/Static Tester DPS450 is used for this test complete paragraph A. If a Barfield Pitot/Static Tester DPS500 is used, go to paragraph B.

A. Pitot and Static System Leak Test with Barfield Pitot/Static Tester DPS450:

Procedure is given for the left side and is the same for the right side.

Refer to [Fig. 501, Sheet 1](#).

CAUTION: DO NOT OVER TIGHTEN HOSES. DAMAGE MAY OCCUR TO TEST EQUIPMENT. HOSES SHOULD BE SNUG.

CAUTION: THE LEAK TEST CAN BE ACCOMPLISHED WITH ELECTRICAL POWER OFF. MAKE SURE THAT IF THE WOW BOX IS CONNECTED, THE SWITCHES ARE SET TO WONW DURING THIS TEST IF ELECTRICAL POWER IS USED. WITH WEIGHT OFF WHEELS, THE HEATERS ARE COMMANDED ON BY THE AIRCRAFT COMPUTER SYSTEM. IF THE PITOT/STATIC HEAT ECBS ARE NOT COLLARED OFF, HARM TO PERSONNEL OR AIR DATA TEST EQUIPMENT CAN OCCUR.

NOTE: Refer to step (1) if using Air Data Accessories Kit ; (Nav Aids PN ADA500945) or step (2) if using Air Data Accessories Kit (NavAids P/N ADA500MD-945).

- (1) Connect the Barfield Pitot/Static Tester DPS450 to the aircraft using the Air Data Accessories Kit ; (Nav Aids PN ADA500945) as follows:
 - (a) Install the Pitot/Angle of Attack (AOA) Probe Adaptor (Nav Aids, APA94520-4-4-4) (7) with the label TOP facing up on the Pitot/AOA probe. If needed, lubricate with Pitot adaptor lubricating fluid (Part Number LF5050).

Adjust the Pitot/AOA Probe Adaptor nozzles to align with the holes of the Pitot/AOA probe.

NOTE: No other lubricating fluid is permitted. Malfunction of the equipment in flight is possible.

NOTE: When installing the pressure test adapters, make sure that the seal is good by applying a firm force to seat the adapter on the probe.

NOTE: The Pitot/AOA probes with a drain hole near the base of mast, must have the drain hole covered. The drain hole must be covered with teflon or vinyl tape. Failure to do so will result in a failure of this test.

(b) Connect the Pitot Test Hose Assembly (long hose) (3) to the Pt connection (2) on the Barfield Pitot/Static Tester DPS450. Connect the other end of the long hose to the quick-connect cross (4).

(c) Connect the Pitot Test Hose Assembly (three short hoses) (5, 6 and 8) to the quick-connect cross. Connect the other end of the short hoses to the upper, center and lower connections on the Pitot/AOA Probe Adaptor (7).

NOTE: Make sure that the Pitot/AOA Probe Adaptor nozzles are still aligned with the holes on the Pitot/AOA probe.

(d) Connect the Static Port Adaptor (Nav Aids, SS53515-4-4) (10) to the left static port and finger tighten the screws to seat the seals over the static ports.

(e) Connect the Static Test Hose Assembly ; (Nav Aids PN E500-5160) (long hose) (12) to the Barfield Pitot/Static Tester DPS450 Ps connection (1). Connect the other end of the Static Test Hose Assembly to the quick connect cross (11).

(f) Connect the (short hose) (9) to the top fitting of the Static Port Adaptor (Nav Aids, SS53515-4-4) (10). Connect the other end of the short hose to the quick connect cross (11).

(2) Connect the Barfield Pitot/Static Tester DPS450 to the aircraft using the Air Data Accessories Kit (NavAids P/N ADA500MD-945) as follows:

NOTE: When installing the pressure test adapters, make sure that the seal is good by applying a firm force to seat the adapter on the probe.

NOTE: The P22201MD-4 adapter contains a built-in seal that covers the Pitot/AOA probe drain hole. If using the P22201-3 adapter, the drain hole must be covered with teflon or vinyl tape.

NOTE: The Pitot/AOA probes with a drain hole near the base of the mast, must have the drain hole covered. Failure to do so will result in a failure of this test.

(a) Connect the Pitot Test Hose Assembly (3) to the Pt connection (2) on the Barfield Pitot/Static Tester DPS450. DO NOT OVERTIGHTEN.

(b) Connect the opposite end of the hose to the NAV Aids P22201MD-4 adapter.

(c) Install the NAV Aids P22201MD-4 adapter to the Pitot/AOA Probe. Make sure that the internal seal of the adapter covers the pitot probe drain hole. If using the

P22201-3 adapter, make sure that the pitot probe drain hole is covered with tape. If needed, lubricate with Pitot adaptor lubricating fluid (Part Number LF5050).

NOTE: No other lubricating fluid is permitted. Malfunction of the equipment in flight is possible.

- (d) Connect the Static Port Adaptor (Nav Aids, SS53515-4-4) (10) to the left static port and finger tighten the screws to seat the seals over the static ports.
 - (e) Connect the Static Test Hose Assembly ; (Nav Aids PN E500-5160) (long hose) (12) to the Barfield Pitot/Static Tester DPS450 Ps connection (1).
 - (f) Connect the other end of the hose (9) to the top fitting of the Static Port Adaptor (Nav Aids, SS53515-4-4) (10).
- (3) Use tape to seal the opposite-side Static port.
- NOTE:** Make sure to select a tape that does not leave any adhesive residue on the static port when the test is complete.
- (4) Power on the Barfield Pitot/Static Tester DPS450. Wait for the Barfield Pitot/Static Tester DPS450 to the Confirm Settings.
- After a successful self-test sequence, the system changes to the Leak Measure mode.
- NOTE:** Skip this step if the Barfield Pitot/Static Tester DPS450 is in Quad mode. Quad mode displays four values: ALT, ROC, CAS, and Rt CAS.
- (5) Press Setup and press F1 to select Display. Press F3 to select Quad. Make sure that Alt is in ft, CAS is in kts and Rt CAS is in kts/min. If not, press F2 to select Units and then press F1 to select ft kts ft/min and press F4 to save settings. Press Clear/Quit to return to Main Menu displayed in the upper right corner.
 - (6) Press LEAK MEASURE/ CONTROL for CONTROL MODE.
 - (7) Press F1 to select Rate Timer and then press F3 to select Set Wait.
 - (8) Press 5 and then press Enter.
 - The Set Wait will be updated to 5 minutes.
 - (9) Press F4 to select Set Time, press 1, and then press Enter.
 - The Set Time will be updated to 1 minute.
 - (10) Press CLEAR/QUIT to return to Main Menu.
 - (11) Press ROC RATE Ps to select the ROC control aim, enter 4000 and press the Enter button.
 - (12) Press ALT Ps to select the ALT control aim, enter 30000 and press the Enter button.
 - The system starts to control to the new set point.
 - (13) Press SPEED Qc, enter 200 and press Enter. Wait for at least a 15 second stabilization period after the altitude and airspeed achieve these new air data parameter set point values to continue.
 - (14) Press LEAK MEASURE/CONTROL to change to LEAK MEASURE MODE.

-
- (15) Press F1 twice to Start Timing.
- After the Waiting and Timing intervals are complete, the Barfield Pitot/Static Tester DPS450 displays Timed Rates Available.
- (16) Check that the maximum ROC is 100 ft/min or less and the maximum Rt CAS is 2 kts/min. or less.
- If the leak rate is not within tolerances, refer to Leak Testing in the Barfield Pitot/Static Tester DPS450 and Connecting Hoses ([SUBTASK AMM-34-10-00-071-701-003](#)). Subtract the Barfield Pitot/Static Tester DPS450 leak check altitude value recorded in Leak Testing in the Barfield Pitot/Static Tester DPS450 and Connecting Hoses subtask from the value obtained in this section in order to get a corrected total system leak value.
- (17) Press LEAK MEASURE/CONTROL to return to CONTROL MODE.
- (18) If no further maintenance is required, remove all of the Nav Aids test equipment from the aircraft. Stow the Air Data Accessories Kit ; (Nav Aids PN ADA500945) equipment and Barfield Pitot/Static Tester DPS450.
- (19) Remove the tape from the opposite-side Static port.
- B. Pitot and Static System Leak Test with Barfield Pitot/Static Tester DPS500:
Procedure is given for the left side and is the same for the right side unless noted.
- NOTE:** To use the Barfield Pitot/Static Tester DPS500 Remote during this test, connect the Remote (P/N ADTS405-1728-37M0) and Remote Cord (P/N ADTS405-1728-28M0) to the Barfield Pitot/Static Tester DPS500 Hand Terminal Connection.
- NOTE:** The Pt Hose (p/n ADTS405-1729-62m0) may be used in place of the hose (p/n E500-7270). The AN6-AN4 adaptor is not needed if using the ADTS405-1729-62m0 Pt hose.
- NOTE:** The Ps Hose (p/n ADTS405-1729-61m0) may be used in place of the hose (p/n E500-5160), The AN6-AN4 connector is not required if using this configuration. Install a AN5 to AN4 adaptor on the Barfield DPS500 Ps connection.
- CAUTION:** DO NOT OVER TIGHTEN HOSES. DAMAGE MAY OCCUR TO TEST EQUIPMENT. HOSES SHOULD BE SNUG.
- CAUTION:** THE LEAK TEST CAN BE DONE WITH ELECTRICAL POWER OFF. MAKE SURE THAT IF THE WOW BOX IS CONNECTED, THE SWITCHES ARE SET TO WONW DURING THIS TEST IF ELECTRICAL POWER IS USED. WITH WEIGHT OFF WHEELS, THE HEATERS ARE COMMANDED ON BY THE AIRCRAFT COMPUTER SYSTEM. IF THE PITOT/STATIC HEAT ECBS ARE NOT COLLARED OFF, HARM TO PERSONNEL OR AIR DATA TEST EQUIPMENT CAN OCCUR.
- NOTE:** Refer to step (1) if using the Air Data Accessories Kit ; (Nav Aids PN ADA500945) or step (2) if using the Air Data Accessories Kit (NavAids P/N ADA500MD-945).

- (1) Connect the Barfield Pitot/Static Tester DPS500 to the aircraft as follows:
 - (a) Install the Pitot/Angle of Attack (AOA) Probe Adaptor (Nav Aids, APA94520-4-4-4) (7) with the label TOP facing up on the Pitot/AOA probe. If needed, lubricate with Pitot adaptor lubricating fluid (Part Number LF5050). Adjust the Pitot/AOA Probe Adaptor nozzles to align with the holes of the Pitot/AOA probe.

NOTE: No other lubricating fluid is allowed, possible malfunction of the equipment in flight is possible

NOTE: When installing the pressure test adapters, make sure of a good seal by applying a firm force to seat the adapter on the probe.

NOTE: If present, cover the probe drain hole with vinyl tape.
 - (b) Connect the Pitot Test Hose Assembly (long hose) (3) to the Pt connection (2) on the Barfield Pitot/Static Tester DPS500. Connect the other end of the long hose (3) to the quick connect cross (4).
 - (c) Connect the Pitot Test Hose Assembly (one short hose) (5) to the quick connect cross (4). Connect the other end of the short hose (5) to the center connection on the Pitot/AOA Probe Adaptor (7).

NOTE: Make sure that the Pitot/AOA Probe Adaptor nozzles are still aligned with the holes on the Pitot/AOA probe.
 - (d) Connect the Static Test Hose Assembly ; (Nav Aids PN E500-5160) (12) to the Barfield Pitot/Static Tester DPS500 Ps connection (1).
 - (e) Connect the other end of the Static Test Hose Assembly (12) to the top fitting of the Static Port Adaptor (Nav Aids, SS53515-4-4) (10).
 - (f) Connect the Static Port Adaptor (Nav Aids, SS53515-4-4) (10) to the left Static port with the connected fitting to the top port and finger tighten the screws to seat the seals over the Static ports.

NOTE: The right static upper port can be tested from the left Static lower port by connecting the short hose to the lower port connection on the Static Port Adaptor. The aircraft's left lower port is connected to the right upper port and the left upper port is connected to the right lower port by aircraft design. Refer to [Fig. 504, Sheet 1](#).
- (2) Connect the Barfield Pitot/Static Tester DPS500 to the aircraft using the Air Data Accessories Kit (NavAids P/N ADA500MD-945) as follows:

NOTE: When installing the pressure test adapters, make sure that the seal is good by applying a firm force to seat the adapter on the probe.

NOTE: The P22201MD-4 adapter contains a built-in seal that covers the Pitot/AOA probe drain hole. If using the P22201-3 adapter, the drain hole must be covered with teflon or vinyl tape.

NOTE: The Pitot/AOA probes with a drain hole near the base of the mast, must have the drain hole covered. Failure to do so will result in a failure of this test.

- (a) Connect the Pitot Test Hose Assembly (3) to the Pt connection (2) on the Barfield Pitot/Static Tester DPS500. DO NOT OVERTIGHTEN.
 - (b) Connect the opposite end of the hose to the NAV Aids P22201MD-4 adapter.
 - (c) Install the NAV Aids P22201MD-4 adapter to the Pitot/AOA Probe. Make sure that the internal seal of the adapter covers the pitot probe drain hole. If using the P22201-3 adapter, make sure that the pitot probe drain hole is covered with tape. If needed, lubricate with Pitot adaptor lubricating fluid (Part Number LF5050).
NOTE: No other lubricating fluid is permitted. Malfunction of the equipment in flight is possible.
 - (d) Connect the Static Test Hose Assembly ; (Nav Aids PN E500-5160) (12) to the Barfield Pitot/Static Tester DPS500 Ps connection (1) .
 - (e) Connect the other end of the Static Test Hose Assembly (12) to the top fitting of the Static Port Adaptor (Nav Aids, SS53515-4-4) (10) .
 - (f) Connect the Static Port Adaptor (Nav Aids, SS53515-4-4) (10) to the left Static port with the connected fitting to the top port and finger tighten the screws to seat the seals over the Static ports.
- (3) Use tape to seal the opposite-side static port.
NOTE: Make sure to select a tape that does not leave any adhesive residue on the Static port when the test is complete.
 - (4) Power on the Barfield Pitot/Static Tester DPS500 by selecting OPERATE and PUMP switches to ON. Wait for the Barfield Pitot/Static Tester DPS500 to confirm the settings.
 - After a successful self-test sequence, the system changes to the Warm Up mode.
 - (5) Press ROC Ps RATE to select the ROC control aim, enter 4000 and press the Enter button.
 - (6) Press ALT Ps to select the ALT control aim, enter 30000 and press the Enter button.
 - The system starts to control to the new set point.
 - (7) Press SPEED Qc and enter 200 then press Enter. Wait for at least a 15 second stabilization period after the altitude and airspeed achieve these new air data parameter set point values to continue.
 - (8) Press LEAK MEASURE/CONTROL to change to LEAK MEASURE MODE.
 - (9) Press RATE TIMER.
 - (10) Press F3.
 - After the Waiting and Timing intervals are complete, the Barfield Pitot/Static Tester DPS500 displays Timed Rates.
 - (11) Check that the maximum ROC is 100 ft/min or less and the maximum Rt CAS is 2 kts/min or less.

- If the leak rate is not within tolerances, refer to Leak Testing in the Barfield Pitot/Static Tester DPS500 and Connecting Hoses [SUBTASK AMM-34-10-00-071-701-003](#) and subtract the Barfield Pitot/Static Tester DPS500 leak check altitude value recorded in Leak Testing the Barfield Pitot/Static Tester DPS500 and Connecting Hoses subtask from the value obtained in this section in order to get a corrected total system leak value.
- (12) Press LEAK MEASURE/CONTROL to return to CONTROL MODE.
 - (13) If no further maintenance is required, remove all of the Nav Aids test equipment from the aircraft. Stow all the Air Data Accessories Kit ; (Nav Aids PN ADA500945) equipment and the Barfield Pitot/Static Tester DPS500.
 - (14) Remove the tape from the opposite-side Static port.

5. **Standby Pitot/Static Probe System Leak Test**

SUBTASK AMM-34-10-00-071-701-002

CAUTION: DO NOT PRESSURIZE THE AIRCRAFT DURING TESTING.

NOTE: If a Barfield Pitot/Static Tester DPS450 is used for this test complete paragraph A. If a Barfield Pitot/Static Tester DPS500 is used, go to paragraph B.

- A. Complete the Standby Pitot/Static System Leak Test (using the Barfield Pitot/Static Tester DPS450) as follows:

CAUTION: DO NOT OVER TIGHTEN HOSES. DAMAGE MAY OCCUR TO TEST EQUIPMENT. HOSES SHOULD BE SNUG.

CAUTION: THE LEAK TEST CAN BE ACCOMPLISHED WITH ELECTRICAL POWER OFF. MAKE SURE THAT IF THE WOW BOX IS CONNECTED, THE SWITCHES ARE SET TO WONW DURING THIS TEST IF ELECTRICAL POWER IS USED. WITH WEIGHT OFF WHEELS, THE HEATERS ARE COMMANDED ON BY THE AIRCRAFT COMPUTER SYSTEM. IF THE PITOT/STATIC HEAT ECBS ARE NOT COLLARED OFF, HARM TO PERSONNEL OR AIR DATA TEST EQUIPMENT CAN OCCUR.

NOTE: Refer to step (1) if using the Air Data Accessories Kit ; (Nav Aids PN ADA500945) or step (2) if using the Air Data Accessories Kit (NavAids P/N ADA500MD-945).

- (1) Connect the Barfield Pitot/Static Tester DPS450 to the aircraft Standby Pitot/Static probe as follows:
 - (a) Attach the Pitot/Static probe adaptor (PS35210-4-4) (6) to the Standby Pitot/Static probe.
 - (b) Connect the hose (3) from the Pt connection (2) on the Barfield Pitot/Static Tester DPS450 to the end fitting on the Pitot/Static probe adaptor (PS35210-4-4) (6) .

- (c) Connect the hose from the Ps (1) connection on the Barfield Pitot/Static Tester DPS450 to the fitting on the side on the Pitot/Static probe adaptor (PS35210-4-4) (6).

NOTE: Cover the probe drain hole with vinyl tape.

- (2) Connect the Barfield Pitot/Static Tester DPS500 to the aircraft using the Air Data Accessories Kit (NavAids P/N ADA500MD-945) as follows:
- (a) Remove the P22201MD-4 adapter (or the P22201-3 adapter) from the Pt Hose. Connect the hose from the Pt adapter on the Barfield to PS35210MD-4-4 adapter (or PS35210- 4-4 adapter) connector marked PITOT (this is the connector at the end of the adapter).
- (b) Disconnect the hose from the static PTA and connect to the other PS35210 connector (connector on side of adapter). Connect the PS35210 adapter to the Pitot/Static probe, make sure of a complete coverage of the static ports on the Pitot/Static probe.

NOTE: The PS35210MD-4-4 adapter contains a built-in seal that covers the pitot static probe drain hole. If using the PS35210-4-4 adapter, the drain hole must be covered with vinyl tape.

NOTE: The Pitot/Static probe is the upper pitot probe on the left hand side.

- (3) Press CLEAR/QUIT to return to main menu on Barfield Pitot/Static Tester DPS450.
- (4) Press F1 to select Rate Timer and then press F3 to select Set Wait.
- (5) Press 5 and then press ENTER.
- The Set Wait will be updated to 5 minutes.
- (6) Press F4 to select Set Time, press 1, and then press ENTER.
- The Set Time will be updated to 1 minute.
- (7) Press CLEAR/ QUIT to return to Main Menu.
- (8) Press LEAK MEASURE/ CONTROL for CONTROL MODE.
- (9) Press ROC RATE Ps to select the ROC control aim, enter 4000 and press Enter.
- (10) Press ALT Ps to select the ALT control aim, enter 30000 and press Enter.
- The system starts to control to the new set point.
- (11) Press SPEED Qc, enter 200 and press Enter. Wait for at least a 15 second stabilization period after the altitude and airspeed achieve these new air data parameter set point values to continue.
- (12) Press LEAK MEASURE/CONTROL to change to LEAK MEASURE MODE.
- (13) Press F1 twice to Start Timing.
- After the Waiting and Timing intervals are complete, the Barfield Pitot/Static Tester DPS450 displays Timed Rates Available.
- (14) Check the maximum ROC is 100 ft/min or less and the maximum Rt CAS is 2 kt/min or less.

- If the leak rate is not within tolerances, refer to Leak Testing the Barfield Pitot/Static Tester DPS450 and Connecting Hoses ([SUBTASK AMM-34-10-00-071-701-003](#)) and subtract the Barfield Pitot/Static Tester DPS450 leak check altitude value recorded in Leak Testing the Barfield Pitot/Static Tester DPS450 and Connecting Hoses [SUBTASK AMM-34-10-00-071-701-003](#) from the value obtained in this section in order to get a corrected total system leak value.
- (15) Press the LEAK MEASURE/CONTROL to return to CONTROL MODE.
- (16) If no further maintenance is required, remove all of the Nav Aids test equipment from the aircraft. Stow the Air Data Accessories Kit ; (Nav Aids PN ADA500945) equipment and Barfield Pitot/Static Tester DPS450.
- B. Complete the Standby Pitot/Static System Leak Test (using the Barfield Pitot/Static Tester DPS500) as follows:

CAUTION: DO NOT OVER TIGHTEN HOSES. DAMAGE MAY OCCUR TO TEST EQUIPMENT. HOSES SHOULD BE SNUG.

CAUTION: THE LEAK TEST CAN BE ACCOMPLISHED WITH ELECTRICAL POWER OFF. MAKE SURE THAT IF THE WOW BOX IS CONNECTED, THE SWITCHES ARE SET TO WONW DURING THIS TEST IF ELECTRICAL POWER IS USED. WITH WEIGHT OFF WHEELS, THE HEATERS ARE COMMANDED ON BY THE AIRCRAFT COMPUTER SYSTEM. IF THE PITOT/STATIC HEAT ECBS ARE NOT COLLARED OFF, HARM TO PERSONNEL OR AIR DATA TEST EQUIPMENT CAN OCCUR.

NOTE: Refer to step (1) if using the Air Data Accessories Kit ; (Nav Aids PN ADA500945) or step (2) if using the Air Data Accessories Kit (NavAids P/N ADA500MD-945).

- (1) Connect the Barfield Pitot/Static Tester DPS450 to the aircraft Standby Pitot/Static probe as follows:
- (a) Attach the Pitot/Static probe adaptor (PS35210-4-4) (6) to the Standby Pitot/Static probe.
 - (b) Connect the hose (3) from the Pt connection (2) on the Barfield Pitot/Static Tester DPS450 to the end fitting on the Pitot/Static probe adaptor (PS35210-4-4) (6) .
 - (c) Connect the hose from the Ps (1) connection on the fitting on the side on the Pitot/Static probe adaptor (PS35210-4-4) (6) .
- NOTE:** Cover the probe drain hole with vinyl tape.
- (2) Connect the Barfield Pitot/Static Tester DPS500 to the aircraft using the Air Data Accessories Kit (NavAids P/N ADA500MD-945) as follows:
- (a) Remove the P22201MD-4 adapter (or the P22201-3 adapter) from the Pt Hose. Connect the hose from the Pt adapter on the Barfield to the PS35210MD-4-4

adapter (or PS35210- 4-4 adapter) connector marked PITOT (this is the connector at the end of the adapter).

- (b) Disconnect the hose from the static PTA and connect to the other PS35210 connector (connector on the side of the adapter). Connect the PS35210 adapter to the Pitot/Static probe, make sure of complete coverage of the static ports on the Pitot/Static probe.

NOTE: The PS35210MD-4-4 adapter contains a built-in seal that covers the pitot static probe drain hole. If using the PS35210-4-4 adapter, the drain hole must be covered with vinyl tape.

NOTE: The Pitot/Static probe is the upper pitot probe on the left hand side.

- (3) Press LEAK MEASURE/ CONTROL for CONTROL MODE.
- (4) Press ROC RATE Ps to select the ROC control aim, enter 4000 and press Enter.
- (5) Press ALT Ps to select the ALT control aim, enter 30000 and press Enter.
 - The system starts to control to the new set point.
- (6) Press SPEED Qc and enter 200 then press ENTER. Wait for at least a 15 second stabilization period after the altitude and airspeed achieve these new air data parameter set point values to continue.
- (7) Press LEAK MEASURE/CONTROL to change to LEAK MEASURE MODE.
- (8) Press RATE TIMER.
- (9) .Press F3
 - After the Waiting and Timing intervals are complete, the DPS500 will display Timed Rates.
- (10) Check the maximum ROC is 100 ft/min or less and the maximum Rt CAS is 2 kt/min or less.
- (11) Press the LEAK MEASURE/CONTROL to return to CONTROL MODE.
- (12) If no further maintenance is required, remove all of the Nav Aids test equipment from the aircraft. Stow all the Air Data Accessories Kit ; (Nav Aids PN ADA500945) equipment and Barfield Pitot/Static Tester DPS500.

6. Leak Testing the Barfield Pitot/Static Tester DPS450 and Connecting Hoses.

SUBTASK AMM-34-10-00-071-701-003

- A. If leakage is excessive during the left and right Pitot and Static System Leak Test for unpressurized aircraft, do the following test with the Barfield Pitot/Static Tester DPS450:

CAUTION: DO NOT OVER TIGHTEN HOSES. DAMAGE MAY OCCUR TO TEST EQUIPMENT. HOSES SHOULD BE SNUG.

- (1) Connect the Nav Aids Hose E500-7270 (approximately 8 feet long) to the Barfield Pitot/Static Tester DPS450 Pt connector. Connect the other end of the E500-7270 to

the Pitot/AOA pressure test hose fitting. Connect the pressure test hose fitting to the PT421-4520 Pre-Test Probe.

- (2) Connect the Nav Aids Hose E500-5160 (approximately 4 feet long) or (E500-5170 is acceptable) to the Barfield Pitot/Static Tester DPS450 Ps connector. Connect the other end of the E500-5160 to the Static Port Adaptor (Nav Aids, SS53515-4-4). Connect the Static Test Adaptor to the PTS515 Pre-Test Plate.
- (3) Power on the Barfield Pitot/Static Tester DPS450. Wait two minutes for the Barfield Pitot/Static Tester DPS450 to confirm the settings.
 - After a successful self-test sequence, the system changes to the Leak Measure mode.
- (4) Skip this step if the Barfield Pitot/Static Tester DPS450 is in Quad mode. Quad mode will display four values: Ps, RtPc, Qc, RtQc. Press SETUP, press F1 to select Display. Press F3 to select Quad. Make sure that Alt is in ft, CAS is in kts and Rt CAS is in kts/min. If not, press F2 to select Units, press F1 to select ft Kts ft/min and press F4 to save settings. Press Clear/Quit to return to the Main Menu displayed in the upper right corner.
- (5) Press ALT Ps, ROC RATE Ps, SPEED Qc, and RATE to display the appropriate air data parameters.
- (6) Press CLEAR QUIT for the Main Menu displayed in the upper right corner. Several attempts of pressing the CLEAR/QUIT button may be needed to return to the Main Menu.
- (7) Press LEAK MEASURE/CONTROL to scroll to the CONTROL MODE displayed in lower left corner.
- (8) Press ROC RATE Ps to select the ROC control aim. Using the keypad, enter 4000 and press ENTER. Press ALT Ps to select the altitude control aim, enter 10000 and press ENTER.
 - The ROC and ALT control aim values will be updated.
- (9) Press SPEED Qc, enter 200 then press ENTER. Wait for at least a 15 second stabilization period after the ROC and CAS achieves the new air data parameter set points values before moving to the next step.
- (10) Press LEAK MEASURE/CONTROL to change to LEAK MEASURE MODE.
- (11) Press F1 to select Rate Timer and then press F3 to select Set Wait. Press 0.3 and then Enter.
- (12) Press F4 to select Set Time, press 0.3 and then ENTER.
 - The Set Wait and Set Time will both be updated to 00m.30s.
- (13) Press F1: Start Timer.
 - The display starts the count down Waiting timer followed by the Timing timer. After the Timing timer has expired, the ROC and Rt CAS will display Timed Leak Measure with the final values. Record these values.

- Make sure that the ROC is less than ± 25 ft/min and Rt CAS is less than ± 0.25 kt/min.
- (14) Press CLEAR QUIT to return to the main menu.
 - (15) Press LEAK MEASURE/CONTROL to return to CONTROL MODE.
 - (16) Press GROUND to go to atmospheric pressure. Press F1 to select [Yes] to confirm.
 - (17) After the Barfield Pitot/Static Tester DPS450 displays the SAFE AT GROUND prompt, power off the test set and remove the hose caps.
 - (18) Return to the test section previously run to incorporate the values from Leak Testing the Barfield Pitot/Static Tester DPS450 and Connecting Hoses section.

7. Angle of Attack Test

SUBTASK AMM-34-10-00-071-701-004

NOTE: If a Barfield Pitot/Static Tester DPS450 is used for this test complete paragraph A. If a Barfield Pitot/Static Tester DPS500 is used, go to paragraph B.

A. Angle of Attack Test with the Barfield Pitot/Static Tester DPS450:

Procedure is given for the left side and is the same for the right side.

Refer to [Fig. 502, Sheet 1](#)

- (1) Connect the WOW Box to the aircraft and make sure that the ECBs are collared.
Refer to [SUBTASK AMM-34-10-00-071-921-001](#).
- (2) Select WOffW on the WOW test box.
- (3) Set the transponder to STBY on the PFD.
- (4) Make sure both the left and right PFD baro are set to 29.92 by using the BARO SET knob on the (ACP) Autopilot Control Panel. Also make sure that the baro setting matches on the left and right PFD.

NOTE: Refer to step (5) if using the Air Data Accessories Kit ; (Nav Aids PN ADA500945) or step (6) if using the Air Data Accessories Kit (NavAids P/N ADA500MD-945).

- (5) Connect the Barfield Pitot/Static Tester DPS450 to the aircraft using the Air Data Accessories Kit ; (Nav Aids PN ADA500945) as follows:

CAUTION: DO NOT OVER TIGHTEN HOSES. DAMAGE MAY OCCUR TO TEST EQUIPMENT. HOSES SHOULD BE SNUG.

NOTE: The Pitot/AOA probes with a drain hole near the base of mast, must have the drain hole covered. Failure to do so will result in a failure of this test.

- (a) Install the Pitot/Angle of Attack (AOA) Probe Adaptor (Nav Aids, APA94520-4-4-4) (7) with the label TOP facing up on the Pitot/AOA probe. If needed, lubricate with Pitot adaptor Lubricating fluid Part Number LF5050. Adjust

the Pitot/AOA Probe Adaptor nozzles to align with the holes of the Pitot/AOA probe.

- (b) Connect the Pitot Test Hose Assembly (long hose) (3) to the Pt connection (2) on the Barfield Pitot/Static Tester DPS450. Connect the other end of the long hose (3) to the quick-connect cross (4).
- (c) Connect the Pitot Test Hose Assembly (two short hoses) (5 and 6) to the quick-connect cross (4). Connect the other ends of the two short hoses (5 and 6) to the center and lower connections on the Pitot/AOA Probe Adaptor (7).

NOTE: Make sure that the Pitot/AOA Probe Adaptor nozzles are still aligned with the holes on the Pitot/AOA probe.

- (6) Connect the Barfield Pitot/Static Tester DPS450 to the aircraft using the Air Data Accessories Kit (NavAids P/N ADA500MD-945) as follows:
 - (a) Remove the PS35210 Pressure Test Adaptor from the Pitot/Static probe.
 - (b) Remove the E500-7270 hose from the PITOT (end) connector of the PS35210 adapter and connect to a NAV Aids quick connect cross (leave other end of hose connected to the Barfield Pt connector). Connect (2) LH and/or RH MFP Pitot hoses approximately 2 ft long to the quick disconnect cross and then to the Middle and Lower Nozzles of the NAV Aids APA94520MD-4-4-4 (or APA94520-4-4-4) Pressure Test Adaptor.
 - (c) Connect another LH and/or RH MFP pitot hose approximately 2 ft long to the upper nozzle of the APA94250 adapter. Connect the other end to a second NAV Aids quick connect cross.
 - (d) Remove the other hose from the PS35210 pitot/static test adaptor and connect it to the same quick connect cross as the upper hose of the APA94520 adapter.
 - (e) Attach an E500-5160 hose to the upper static test adaptor. Attach the other end of the hose to the quick connect cross that is connected to the upper hose of the APA94520 Pitot/AOA test adaptor.
 - (f) If needed Lubricate with Pitot adaptor Lubricating fluid Part # LF5050 (NOTE: No other lubricating fluid is allowed) Insert an APA94520 adapter onto the Left Pitot probe and adjust the PTA nozzles to align with the holes of the Pitot/AOA Probe and adjust until the seals are snug. (DO NOT over tighten)
- (7) Power on the Barfield Pitot/Static Tester DPS450 (if needed).
 - Wait for the Barfield Pitot/Static Tester DPS450 to finish a sequence of pneumatic and internal system checks and the system changes to the Leak Measure mode (shown, lower left display corner).
- (8) Press LEAK MEASURE/CONTROL to select the CONTROL MODE.
- (9) Press ALT Ps, enter 6000, and press Enter.
- (10) Select F2 UNITS then select F3 inHg
 - Units on the display change from kts/min to inHg.
- (11) Press SPEED Qc, enter 0.5 inHg, and press Enter.

- Wait for at least a 15 second stabilization period after the Barfield achieves this new air data set point value (within ± 2 feet & ± 0.010 inHg).
- (12) Record the airspeed on the left PFD.
 - Expected results are 105.5 kts \pm 2.5 kts.
 - (13) Press GROUND to go to the atmospheric pressure. Press F1 to select Yes to confirm.
 - The Barfield Pitot/Static Tester DPS450 displays shows for SAFE AT GROUND.
 - (14) Power off the Barfield Pitot/Static Tester DPS450.
 - (15) If no further maintenance is required, remove all of the Nav Aids test equipment from the aircraft. Stow the Air Data Accessories Kit equipment and Barfield Pitot/Static Tester DPS450. Also, refer to [SUBTASK AMM-34-10-00-071-921-002](#).

B. Angle of Attack Test with the Barfield Pitot/Static Tester DPS500:

Procedure is given for the left side and is the same for the right side.

- (1) Connect the WOW Box to the aircraft and make sure that the ECBs are collared. Refer to [SUBTASK AMM-34-10-00-071-921-001](#).
- (2) Select WOffW on the WOW test box.
- (3) Set the transponder to STBY on the PFD.
- (4) Make sure both the left and right PFD baro are set to 29.92 by using the BARO SET knob on the ACP. Make sure the baro setting matches on the left and right PFD.
NOTE: Refer to step (4) if using the Air Data Accessories Kit ; (Nav Aids PN ADA500945) or step (5) if using the Air Data Accessories Kit (NavAids P/N ADA500MD-945).
- (5) Connect the Barfield Pitot/Static Tester DPS500 to the aircraft using the Air Data Accessories Kit ; (Nav Aids PN ADA500945) as follows:

CAUTION: DO NOT OVER TIGHTEN HOSES. DAMAGE MAY OCCUR TO TEST EQUIPMENT. HOSES SHOULD BE SNUG.

NOTE: The Pitot/AOA probes with a drain hole near the base of mast, must have the drain hole covered. Failure to do so will result in a failure of this test.

NOTE: The Pt Hose (ADTS405-1729- 62m0) may be used in place of the hose (E500-7270). An AN6 – AN4 adaptor is not needed if using the ADTS405-1729-62m0 Pt hose.

- (a) Install the Pitot/Angle of Attack (AOA) Probe Adaptor (Nav Aids, APA94520-4-4-4) (7) with the label TOP facing up on the Pitot/AOA probe. If needed, lubricate with Pitot adaptor Lubricating fluid Part Number LF5050. Adjust Pitot/AOA Probe Adaptor nozzles to align with the holes of the Pitot/AOA probe.
- (b) Connect the Pitot Test Hose Assembly (long hose) (3) to the Pt connection (2) on the Barfield Pitot/Static Tester DPS500. Connect the other end of the long hose (3) to the quick-connect cross (4).

- (c) Connect the Pitot Test Hose Assembly (two short hoses) (5 and 6) to the quick-connect cross (4). Connect the other ends of the two short hoses (5 and 6) to the center and lower connections on the Pitot/AOA Probe Adaptor (7).

NOTE: Make sure that the Pitot/AOA Probe Adaptor nozzles are still aligned with the holes on the Pitot/AOA probe.

- (6) Connect the Barfield Pitot/Static Tester DPS500 to the aircraft using the Air Data Accessories Kit (NavAids P/N ADA500MD-945) as follows:
- (a) Remove the PS35210 Pressure Test Adaptor from the Pitot/Static probe.
 - (b) Remove the E500-7270 hose from the PITOT (end) connector of the PS35210 adapter and connect to a NAV Aids quick connect cross (leave other end of hose connected to the Barfield Pt connector). Connect (2) LH and/or RH MFP Pitot hoses approximately 2 ft long to the quick disconnect cross and then to the Middle and Lower Nozzles of the NAV Aids APA94520MD-4-4-4 (or APA94520-4-4-4) Pressure Test Adaptor.
 - (c) Connect another LH and/or RH MFP pitot hose approximately 2 ft long to the upper nozzle of the APA94250 adapter. Connect the other end to a second NAV Aids quick connect cross.
 - (d) Remove the other hose from the PS35210 pitot/static test adaptor and connect it to the same quick connect cross as the upper hose of the APA94520 adapter.
 - (e) Attach an E500-5160 hose to the upper static test adaptor. Attach the other end of the hose to the quick connect cross that is connected to the upper hose of the APA94520 Pitot/AOA test adaptor.
 - (f) If needed Lubricate with Pitot adaptor Lubricating fluid Part # LF5050 (NOTE: No other lubricating fluid is allowed) Insert the APA94520 adapter onto the Left Pitot probe and adjust the PTA nozzles to align with the holes of the Pitot/AOA Probe and adjust until the seals are snug. (DO NOT over tighten)
- (7) Power on the Barfield Pitot/Static Tester DPS500 by flipping the Operate & Pump toggle switches.
- Wait for the Barfield Pitot/Static Tester DPS500 to finish a sequence of pneumatic and internal system checks and the system changes to the Leak Measure mode (shown, lower left display corner).
- (8) Press LEAK MEASURE/CONTROL to select the CONTROL MODE.
- (9) Press ALT Ps, enter 6000, and press Enter.
- (10) Press SETUP.
- Units on the display change from kts/min to inHg.
- (11) Press F1 (UNITS).
- (12) Press F1 (Next) 6 times until inHg is displayed.
- (13) Press F4 (Save).
- (14) Press CLEAR QUIT twice

- (15) Press SPEED Qc, enter 0.5 inHg, and press Enter.
 - Wait for at least a 15 second stabilization period after the Barfield Pitot/Static Tester DPS500 achieves this new air data set point value to continue.
- (16) Record the airspeed on the left PFD.
 - Expected results are 105.5 knots \pm 2.5 kts.
- (17) Press GROUND to go to atmospheric pressure. Press F1 to select Yes to confirm.
 - The Barfield Pitot/Static Tester DPS500 displays shows for SAFE AT GROUND.
- (18) Press CLEAR QUIT.
- (19) Power off the Barfield Pitot/Static Tester DPS500.
- (20) If no further maintenance is required, remove all of the Nav Aids test equipment from the aircraft. Stow all air data equipment and the Barfield Pitot/Static Tester DPS450. Also, refer to [SUBTASK AMM-34-10-00-071-921-002](#).

8. Pitot and Static Verification Test

SUBTASK AMM-34-10-00-071-701-005

NOTE: If a Barfield Pitot/Static Tester DPS450 is used for this test complete paragraph A. If a Barfield Pitot/Static Tester DPS500 is used, go to paragraph B.

A. Pitot and Static Verification Test with Barfield Pitot/Static Tester DPS450:

Procedure is given for the left side and is the same for the right side unless noted.

Refer to [Fig. 501, Sheet 1](#)

- (1) Connect the WOW Box to the aircraft and make sure that the ECBs are collared. Refer to [SUBTASK AMM-34-10-00-071-921-001](#).
- (2) Set the WOW Box switches to WOnW.
- (3) Power up the aircraft by setting the SYS BATT and START BATT switches to ON and the BUS TIE switch to AUTO.

CAUTION: DO NOT OVER TIGHTEN HOSES. DAMAGE MAY OCCUR TO TEST EQUIPMENT. HOSES SHOULD BE SNUG.

NOTE: Refer to step (4) if using the Air Data Accessories Kit ; (Nav Aids PN ADA500945) or step (5) if using the Air Data Accessories Kit (NavAids P/N ADA500MD-945).

- (4) Connect the Barfield Pitot/Static Tester DPS450 to the aircraft using the Air Data Accessories Kit ; (Nav Aids PN ADA500945) as follows:
 - (a) Install the Pitot/Angle of Attack (AOA) Probe Adaptor (Nav Aids, APA94520-4-4-4) (7) with the label TOP facing up on the Pitot/AOA probe. If needed, lubricate with Pitot adaptor lubricating fluid (Part Number LF5050).

Adjust the Pitot/AOA Probe Adaptor nozzles to align with the holes of the Pitot/AOA probe.

NOTE: No other lubricating fluid is allowed, possible malfunction of the equipment in flight is possible.

NOTE: When installing the pressure test adapters, make sure that the seal is good by applying a firm force to seat the adapter on the probe.

- (b) Connect the Pitot Test Hose Assembly (long hose) (3) to the Pt connection (2) on the Barfield Pitot/Static Tester DPS450. Connect the other end of the long hose (3) to the quick-connect cross (4).
- (c) Connect the Pitot Test Hose Assembly (three short hoses) (5,6 and 8) to the quick-connect cross (4). Connect the other ends of the three short hoses (5,6 and 8) to the upper, center and lower connections on the Pitot/AOA Probe Adaptor (7).

NOTE: Make sure that the Pitot/AOA Probe Adaptor nozzles are still aligned with the holes on the Pitot/AOA probe.

- (d) Connect the Static Test Hose Assembly ; (Nav Aids PN E500-5160) (long hose) (12) to the Barfield Pitot/Static Tester DPS450 Ps connection. Connect the other end of the long hose (12) to the quick-connect cross (11). Connect the static short hose (9) to the top fitting of the Static Port Adaptor (Nav Aids, SS53515-4-4) (10).
- (e) Connect the Static Port Adaptor (Nav Aids, SS53515-4-4) (10) to the left Static port with the connected fitting to the top port and finger tighten the screws to seat the seals over the Static ports.

- (5) Connect the Barfield Pitot/Static Tester DPS450 to the aircraft using the Air Data Accessories Kit (NavAids P/N ADA500MD-945) as follows:

NOTE: When installing the pressure test adapters, make sure that the seal is good by applying a firm force to seat the adapter on the probe.

NOTE: The P22201MD-4 adapter contains a built-in seal that covers the Pitot/AOA probe drain hole. If using the P22201-3 adapter, the drain hole must be covered with teflon or vinyl tape.

NOTE: The Pitot/AOA probes with a drain hole near the base of mast, must have the drain hole covered. Failure to do so will result in a failure of this test.

- (a) Connect the Pitot Test Hose Assembly (3) to the Pt connection (2) on the Barfield Pitot/Static Tester DPS450. DO NOT OVERTIGHTEN.
- (b) Connect the opposite end of the hose to the NAV Aids P22201MD-4 adapter.
- (c) Install the NAV Aids P22201MD-4 adapter to the Pitot/AOA Probe. Make sure that the internal seal of the adapter covers the pitot probe drain hole. If using the P22201-3 adapter, make sure that the pitot probe drain hole is covered with tape. If needed, lubricate with Pitot adaptor lubricating fluid (Part Number LF5050).

NOTE: No other lubricating fluid is permitted. Malfunction of the equipment in flight is possible.

- (d) Connect the Static Port Adaptor (Nav Aids, SS53515-4-4) (10) to the left static port and finger tighten the screws to seat the seals over the static ports.
 - (e) Connect the Static Test Hose Assembly ; (Nav Aids PN E500-5160) (long hose) (12) to the Barfield Pitot/Static Tester DPS450 Ps connection (1).
 - (f) Connect the other end of the hose (9) to the top fitting of the Static Port Adaptor (Nav Aids, SS53515-4-4) (10).
- (6) Use tape to seal the opposite-side static port.
- NOTE:** Make sure to select a tape that does not leave any adhesive residue on the Static port when the test is complete.
- (7) Select WOffW on the WOW test box.
 - (8) Set the transponder to STBY on the PFD.
 - (9) If required, set both the left and right PFD baro to 29.92 by using the BARO SET knob on the ACP.
 - Make sure that the baro setting matches on the left and right PFD and the SDU.
 - (10) Turn on the Barfield Pitot/Static Tester DPS450.
 - (11) Set the Barfield Pitot/Static Tester DPS450 static pressure to 40,613 feet and set the airspeed to 159.2 knots as follows:
 - (a) Press ALT Ps to select the ALT control aim, enter 40613 and press ENTER. Press SPEED Qc, enter 159.2 and press ENTER. Wait for at least a 15 second stabilization period after the altitude and airspeed achieve these new air data parameter set point values to continue.
 - (12) Record the left PFD altimeter and airspeed.
 - Expected results are 41,000 ± 40 feet, 160 ± 2.5 knots, and 0.575 ± 0.008 Mach.
 - (13) Set the Barfield Pitot/Static Tester DPS450 static pressure to 29,698 feet and increase the airspeed to 199.3 knots as follows:
 - (a) Press ALT Ps to select the ALT control aim, enter 29698 and press Enter. Press SPEED Qc, enter 199.3 and press ENTER. Wait for at least a 15 second stabilization period after the altitude and airspeed achieve these new air data parameter set point values to continue.
 - (14) Record the left PFD altitude and airspeed.
 - Expected results are 30,000 ± 40 feet, 200 ± 2.7 knots and 0.557 ± 0.006 Mach.
 - (15) Set the Barfield Pitot/Static Tester DPS450 static pressure to 19,706 feet and increase the airspeed to 237.6 knots as follows:
 - (a) Press ALT Ps to select the ALT control aim, enter 19706 and press Enter. Press SPEED Qc, enter 237.6 and press ENTER. Wait for at least a 15 second stabilization period after the altitude and airspeed achieve these new air data parameter set point values to continue.
 - (16) Record the left PFD altitude and airspeed.

- Expected results are 20,000± 40 feet, 240 ± 3 knots and 0.535 ± 0.006 Mach.
- (17) Set the Barfield Pitot/Static Tester DPS450 static pressure to 9,872 feet set the airspeed to 195.9 knots as follows:
- (a) Press ALT Ps to select the ALT control aim, enter 9872" and press Enter. Press SPEED Qc, enter 195.9 and press Enter. Wait for at least a 15 second stabilization period after the altitude and airspeed achieve these new air data parameter set point values to continue.
- (18) Record the left PFD altitude and airspeed.
- Expected results are 10,000± 33 feet and 200 ± 2.7 knots.
- (19) Set the Barfield Pitot/Static Tester DPS450 static pressure to 6,008 feet and set the airspeed to 66.1 knots as follows:
- (a) Press ALT Ps to select the ALT control aim, enter 6008 and press Enter. Press SPEED Qc, enter 66.1 and press Enter. Wait for at least a 15 second stabilization period after the altitude and airspeed achieve these new air data parameter set point values to continue.
- (20) Record the left PFD altimeter and airspeed.
- Expected results are 6,000 ± 25 feet and 65 ± 2 knots.
- (21) Press GROUND to go to atmospheric pressure. Press F1 to select Yes to confirm.
- (a) If the Barfield Pitot/Static Tester DPS450 is not in CONTROL MODE, press LEAK MEASURE/CONTROL.
 - (b) After the Barfield Pitot/Static Tester DPS450 displays shows SAFE AT GROUND prompt, power off the Barfield Pitot/Static Tester DPS450.
- (22) Select WOnW on the WOW test box.
- (23) Make sure that all of the Pitot and Static heat ECB's are collared.
- (24) If no further maintenance is required, remove all of the Nav Aids test equipment from the aircraft. Stow all air data equipment and Barfield Pitot/Static Tester DPS450. Also, refer to [SUBTASK AMM-34-10-00-071-921-002](#).
- B. Pitot and Static Verification Test with the Barfield Pitot/Static Tester DPS500:**
Procedure is given for the left side and is the same for the right side unless specified.
- (1) Connect the WOW Box to the aircraft and make sure that the ECBs are collared. Refer to [SUBTASK AMM-34-10-00-071-921-001](#).
 - (2) Set the WOW Box switches to WOnW.
 - (3) Power up the aircraft by setting the SYS BATT and START BATT switches to ON and the BUS TIE switch to AUTO.

CAUTION: DO NOT OVER TIGHTEN HOSES. DAMAGE MAY OCCUR TO TEST EQUIPMENT. HOSES SHOULD BE SNUG.

NOTE: Refer to step (4) if using the Air Data Accessories Kit ; (Nav Aids PN ADA500945) or step (5) if using the Air Data Accessories Kit (NavAids P/N ADA500MD-945) - un.

- (4) Connect the Barfield Pitot/Static Tester DPS500 to the aircraft using the Air Data Accessories Kit ; (Nav Aids PN ADA500945) as follows:

- (a) Install the Pitot/Angle of Attack (AOA) Probe Adaptor (Nav Aids, APA94520-4-4-4) (7) with the label TOP facing up on the Pitot/AOA probe. If needed, lubricate with Pitot adaptor lubricating fluid (Part Number LF5050). Adjust the Pitot/AOA Probe Adaptor nozzles to align with the holes of the Pitot/AOA probe.

NOTE: No other lubricating fluid is permitted. Malfunction of the equipment in flight is possible.

NOTE: When installing the pressure test adapters, make sure that the seal is good by applying a firm force to seat the adapter on the probe.

- (b) Connect the Pitot Test Hose Assembly (long hose) (3) to the Pt connection (2) on the Barfield Pitot/Static Tester DPS500. Connect the other end of the long hose (3) to the quick-connect cross (4) .
- (c) Connect the Pitot Test Hose Assembly (three short hoses) (5,6 and 8) to the quick-connect cross (4) . Connect the other ends of the three short hoses (5,6 and 8) to the upper, center and lower connections on the Pitot/AOA Probe Adaptor (7) .

NOTE: Make sure that the Pitot/AOA Probe Adaptor nozzles are still aligned with the holes on the Pitot/AOA probe.

- (d) Connect the Static Test Hose Assembly ; (Nav Aids PN E500-5160) (long hose) (12) to the Barfield Pitot/Static Tester DPS500 Ps connection. Connect other end of long hose (12) to the quick-connect cross (11) . Connect the static short hose (9) to the top fitting of the Static Port Adaptor (Nav Aids, SS53515-4-4) (10) .
- (e) Connect the Static Port Adaptor (Nav Aids, SS53515-4-4) (10) to the left static port with the connected fitting to the top port and finger tighten the screws to seat the seals over the static ports.

NOTE: The right static upper port can be tested from the left static lower port by connecting the short hose to the lower port connection on the Static Port Adaptor. The aircraft's left lower port is connected to the right upper port and the left upper port is connected to the right lower port by aircraft design. Refer to [Fig. 503, Sheet 1](#)

- (5) Connect the Barfield Pitot/Static Tester DPS500 to the aircraft using the Air Data Accessories Kit (NavAids P/N ADA500MD-945) as follows:
- NOTE:** When installing the pressure test adapters, make sure that the seal is good by applying a firm force to seat the adapter on the probe.
- NOTE:** The P22201MD-4 adapter contains a built-in seal that covers the Pitot/AOA probe drain hole. If using the P22201-3 adapter, the drain hole must be covered with teflon or vinyl tape.
- NOTE:** The Pitot/AOA probes with a drain hole near the base of mast, must have the drain hole covered. Failure to do so will result in a failure of this test.
- (a) Connect the Pitot Test Hose Assembly (3) to the Pt connection (2) on the Barfield Pitot/Static Tester DPS500. DO NOT OVERTIGHTEN.
- (b) Connect the opposite end of the hose to the NAV Aids P22201MD-4 adapter.
- (c) Install the NAV Aids P22201MD-4 adapter to the Pitot/AOA Probe. Make sure that the internal seal of the adapter covers the pitot probe drain hole. If using the P22201-3 adapter, make sure that the pitot probe drain hole is covered with tape. If needed, lubricate with Pitot adaptor lubricating fluid (Part Number LF5050)..
- NOTE:** No other lubricating fluid is permitted. Malfunction of the equipment in flight is possible.
- (d) Connect the Static Test Hose Assembly ; (Nav Aids PN E500-5160) (12) to the Barfield Pitot/Static Tester DPS500 Ps connection (1) .
- (e) Connect the other end of the Static Test Hose Assembly (12) to the top fitting of the Static Port Adaptor (Nav Aids, SS53515-4-4) (10) .
- (f) Connect the Static Port Adaptor (Nav Aids, SS53515-4-4) (10) to the left Static port with the connected fitting to the top port and finger tighten the screws to seat the seals over the Static ports.
- (6) Use tape to seal the opposite-side static port.
- NOTE:** Make sure to select a tape that does not leave any adhesive residue on the static port when the test is complete.
- (7) Select WOffW on the WOW test box.
- (8) Set the transponder to STBY on the PFD.
- (9) Set both the left and right PFD Baro to 29.92 by using the BARO SET knob on the ACP.
- Make sure the baro setting matches on the left and right PFD.
- (10) Power on the Barfield Pitot/Static Tester DPS500 by selecting OPERATE and PUMP switches to ON. Wait for the Barfield Pitot/Static Tester DPS500 to Confirm Settings.
- After a successful self-test sequence, the system changes to the Warm Up mode.
- (11) Set the Barfield Pitot/Static Tester DPS500 static pressure to 40,613 feet and set the airspeed to 159.2 knots as follows:

-
- (a) Press ALT Ps to select the ALT control aim, enter 40613 and press Enter. Press SPEED Qc, enter 159.2 and press ENTER. Wait for at least a 15 second stabilization period after the altitude and airspeed achieve these new air data parameter set point values to continue.
 - (12) Record the left PFD altitude and airspeed.
 - Expected results are 41,000 ± 40 feet, 160 ± 2.5 knots and 0.575 ± 0.008 Mach.
 - (13) Set the Barfield Pitot/Static Tester DPS500 static pressure to 29,698 feet and increase airspeed to 199.3 knots as follows:
 - (a) Press ALT Ps to select the ALT control aim, enter 29698 and press Enter. Press SPEED Qc, enter 199.3 and press Enter. Wait for at least a 15 second stabilization period after the altitude and airspeed achieve these new air data parameter set point values to continue.
 - (14) Record the left PFD altitude and airspeed.
 - Expected results are 30,000 ± 40 feet, 200 ± 2.7 knots, and 0.557 ± 0.006 Mach.
 - (15) Set the Barfield Pitot/Static Tester DPS500 static pressure to 19,706 feet and increase airspeed to 237.6 knots as follows:
 - (a) Press ALT Ps to select the ALT control aim, enter 19706 and press Enter. Press SPEED Qc, enter 237.6 and press Enter. Wait for at least a 15 second stabilization period after the altitude and airspeed achieve these new air data parameter set point values to continue.
 - (16) Record the left PFD altitude and airspeed.
 - Expected results are 20,000± 40 feet, 240 ± 3 knots, and 0.535 ± 0.006 Mach.
 - (17) Set the Barfield Pitot/Static Tester DPS500 static pressure to 9,872 feet and set airspeed to 195.9 knots as follows:
 - (a) Press ALT Ps to select the ALT control aim, enter 9872 and press Enter. Press SPEED Qc, enter 195.9 and press Enter. Wait for at least a 15 second stabilization period after the altitude and airspeed achieve these new air data parameter set point values to continue.
 - (18) Record the left PFD altitude and airspeed.
 - Expected results are 10,000± 33 feet and 200 ± 2.7 knots.
 - (19) Set the Barfield Pitot/Static Tester DPS500 static pressure to 6,008 feet and set airspeed to 66.1 knots as follows:
 - (a) Press ALT Ps to select the ALT control aim, enter 6008 and press Enter. Press SPEED Qc, enter 66.1 and press Enter. Wait for at least a 15 second stabilization period after the altitude and airspeed achieve these new air data parameter set point values to continue.
 - (20) Record the left PFD altitude and airspeed.
 - Expected results are 6,000 ± 25 feet and 65 ± 2 knots.
 - (21) Press GROUND to go to atmospheric pressure. Press F1 (Go to Ground).

- (a) After the Barfield Pitot/Static Tester DPS500 displays shows SAFE AT GROUND prompt, press CLEAR/QUIT.
- (22) Select WOnW on the WOW test box.
- (23) Make sure that the Pitot and Static heat ECB's are collared.
- (24) If no further maintenance is required, remove all of the NAV Aids test equipment from the aircraft. Stow all air data equipment and the Barfield Pitot/Static Tester DPS500. Also, refer to [SUBTASK AMM-34-10-00-071-921-002](#).

9. **Standby Pitot/Static Probe Verification Test**

SUBTASK AMM-34-10-00-071-701-006

NOTE: If a Barfield Pitot/Static Tester DPS450 is used for this test complete paragraph A. If a Barfield Pitot/Static Tester DPS500 is used, go to paragraph B.

A. Standby Pitot/Static Probe Verification Test with a Barfield Pitot/Static Tester DPS450:

- (1) Connect the WOW Box to the aircraft and make sure that the ECBs are collared. Refer to [SUBTASK AMM-34-10-00-071-921-001](#).
- (2) Set the WOW Box switches to WOnW.
- (3) Power up the aircraft by setting the SYS BATT and START BATT switches to ON and the BUS TIE switch to AUTO.
- (4) Select WOffW on the WOW test box.
- (5) Set the transponder to STBY on the PFD.
- (6) If required, set both the left and right SDU baro to 29.92 by press and HOLD the MENU button until the Baro reads 29.92 (or use ARROWS to adjust the Baro reading)..
NOTE: Right SDU is optional.
 - Make sure the baro setting matches on the left and right SDU.
- (7) Set the static pressure to 39,889 feet and set the airspeed to 197.0 Knots.
 - (a) Press ALT Ps to select the ALT control aim, enter 39889 and press ENTER. Press SPEED Qc and enter 197.0 then press ENTER. Wait for at least a 15 second stabilization period after the altitude and airspeed achieve these new air data parameter set point values to continue.
- (8) Record the Pitot/Static probe Altitude and Airspeed from the SDU.
 - Expected Results: 40,000 ± 105 feet and 190 ± 2.7 knots.
- (9) Set the static pressure to 29,874 feet and set the airspeed to 247.1 Knots.
 - (a) Press ALT Ps to select the ALT control aim, enter 29874 and press ENTER. Press SPEED Qc and enter 247.1 then press ENTER. Wait for at least a 15 second stabilization period after the altitude and airspeed achieve these new air data parameter set point values to continue.

- (10) Record the Standby Pitot/Static probe altitude and airspeed from the SDU.
 - Expected Results: 30000 ± 75 feet and 240 ± 2.7 knots.
 - (11) Set the static pressure to 19,899 feet and increase airspeed to 247.5 Knots.
 - (a) Press ALT Ps to select the ALT control aim, enter 19899 and press ENTER. Press SPEED Qc and enter 247.5 then press ENTER. Wait for at least a 15 second stabilization period after the altitude and airspeed achieve these new air data parameter set point values to continue.
 - (12) Record the Standby Pitot/Static probe altitude and airspeed from the SDU.
 - Expected Results: 20,000 ± 50 feet and 245 ± 3 knots.
 - (13) Set the static pressure to 9,998 feet and set the airspeed to 99.9 Knots.
 - (a) Press ALT Ps to select the ALT control aim, enter 9998 and press ENTER. Press SPEED Qc and enter 99.9 then press ENTER. Wait for at least a 15 second stabilization period after the altitude and airspeed achieve these new air data parameter set point values to continue.
 - (14) Record the Standby Pitot/Static probe altitude and airspeed from the SDU.
 - Expected Results: 10,000 ± 33 feet and 100 ± 3 knots.
 - (15) Set the static pressure to 5,999 feet and set the airspeed to 64.9 Knots.
 - (a) Press ALT Ps to select the ALT control aim, enter 5999 and press ENTER. Press SPEED Qc and enter 64.9 then press ENTER. Wait for at least a 15 second stabilization period after the altitude and airspeed achieve these new air data parameter set point values to continue.
 - (16) Record the Standby Pitot/Static probe altitude and airspeed from the SDU.
 - Expected results are 6,000 ± 30 feet and 65 ± 4 knots.
 - (17) Press GROUND to go to atmospheric pressure. Press F1 to select Yes to confirm.
 - (a) If the Barfield Pitot/Static Tester DPS450 is not in CONTROL MODE, press LEAK MEASURE/CONTROL.
 - (b) After the Barfield Pitot/Static Tester DPS450 displays shows SAFE AT GROUND prompt, power off the Barfield Pitot/Static Tester DPS450.
 - (18) If no further maintenance is required, remove all of the Nav Aids test equipment from the aircraft. Stow all air data equipment and the Barfield Pitot/Static Tester DPS450. Also, refer to [SUBTASK AMM-34-10-00-071-921-002](#).
- B. Standby Pitot/Static Probe Verification Test with a Barfield Pitot/Static Tester DPS500:
- (1) Connect the WOW Box or AMC to the aircraft and make sure that the ECBs are collared. Refer to [SUBTASK AMM-34-10-00-071-921-001](#).
 - (2) Set the WOW Box switches to WOnW.
 - (3) Power up the aircraft by setting the SYS BATT and START BATT switches to ON and the BUS TIE switch to AUTO.

- (4) Select WOffW on the WOW test box.
- (5) Set the transponder to STBY on the PFD.
- (6) If required, set both the left and right SDU baro to 29.92 by press and HOLD the MENU button until the Baro reads 29.92 (or use ARROWS to adjust the Baro reading)..
NOTE: Right SDU is optional.
 - Make sure the baro setting matches on the left and right SDU.
- (7) Set the static pressure to 39,889 feet and set the airspeed to 197.0 Knots.
 - (a) Press ALT Ps to select the ALT control aim, enter 39889 and press ENTER. Press SPEED Qc and enter 197.0 then press ENTER. Wait for at least a 15 second stabilization period after the altitude and airspeed achieve these new air data parameter set point values to continue.
- (8) Record the Standby Pitot/Static probe altitude and airspeed from the SDU.
 - Expected Results: 40,000 ± 105 feet and 190 ± 2.7 knots.
- (9) Set the static pressure to 29,874 feet and set the airspeed to 247.1 Knots.
 - (a) Press ALT Ps to select the ALT control aim, enter 29874 and press ENTER. Press SPEED Qc and enter 247.1 then press ENTER. Wait for at least a 15 second stabilization period after the altitude and airspeed achieve these new air data parameter set point values to continue.
- (10) Record the Standby Pitot/Static probe altitude and airspeed from the SDU.
 - Expected Results: 30,000 ± 75 feet and 240 ± 2.7 knots.
- (11) Set the static pressure to 19,899 feet and increase airspeed to 247.5 Knots.
 - (a) Press ALT Ps to select the ALT control aim, enter 19899 and press ENTER. Press SPEED Qc and enter 247.5 then press ENTER. Wait for at least a 15 second stabilization period after the altitude and airspeed achieve these new air data parameter set point values to continue.
- (12) Record the Standby Pitot/Static probe altitude and airspeed from the SDU.
 - Expected Results: 20,000 ± 50 feet and 245 ± 3 knots.
- (13) Set the static pressure to 9,998 feet and set the airspeed to 99.9 Knots.
 - (a) Press ALT Ps to select the ALT control aim, enter 9998 and press ENTER. Press SPEED Qc and enter 99.9 then press ENTER. Wait for at least a 15 second stabilization period after the altitude and airspeed achieve these new air data parameter set point values to continue.
- (14) Record the Standby Pitot/Static probe altitude and airspeed from the SDU.
 - Expected Results: 10,000 ± 33 feet and 100 ± 3 knots.
- (15) Set the static pressure to 5,999 feet and set the airspeed to 64.9 Knots.
 - (a) Press ALT Ps to select the ALT control aim, enter 5999 and press ENTER. Press SPEED Qc and enter 64.9 then press ENTER. Wait for at least a 15 second

stabilization period after the altitude and airspeed achieve these new air data parameter set point values to continue.

- (16) Record the Standby Pitot/Static probe altitude and airspeed from the SDU.
 - Expected Results: 6000 ± 30 feet and 65 ± 4 knots.
- (17) Press GROUND to go to atmospheric pressure. Press F1 to select Yes to confirm.
 - (a) If the Barfield Pitot/Static Tester DPS500 is not in CONTROL MODE, press LEAK MEASURE/CONTROL.
 - (b) After the Barfield Pitot/Static Tester DPS500 displays shows SAFE AT GROUND prompt, power off the Barfield Pitot/Static Tester DPS500.
- (18) If no further maintenance is required, remove all of the Nav Aids test equipment from the aircraft. Stow all air data equipment and the Barfield Pitot/Static Tester DPS500. Also, refer to [SUBTASK AMM-34-10-00-071-921-002](#).

10. Outside Air Temperature Test

SUBTASK AMM-34-10-00-071-701-007

A. Do an Outside Air Temperature Test as follows:

- (1) Power up the aircraft by setting the SYS BATT and START BATT switches to ON and the BUS TIE switch to AUTO.
- (2) Scroll to the ICE synoptic page on the MFD by using the lower left/right softkey.
- (3) Expected results are that left and right OATs are within ± 5° C of the measured outside temperature. Left and Right PFDs are within ± 2° C of MFD OAT temperature.
- (4) Power down the aircraft by setting the SYS BATT and START BATT switches to OFF and the BUS TIE switch to OPEN.

11. Job Close-Up

SUBTASK AMM-34-10-00-071-921-002

A. If no other tests are required with the Weight On Wheels (WOW) box, select WOnW.

- (1) Re-set the following ECBs:
 - ECB - WEATHER RADAR (L FWD Bus)
 - ECB - DEICE MANIFOLD HTR (R AFT Bus)
 - ECB - L PITOT HEAT (L FWD Bus) or ECB - L PITOT HEAT (BATT Bus)
 - ECB - R PITOT HEAT (R FWD Bus)
 - ECB - L STATIC HEAT (BATT Bus)
 - ECB - L STATIC HEAT (R FWD Bus)
 - ECB - R STATIC HEAT (R FWD Bus)

- ECB - R STATIC HEAT (L FWD Bus)
 - ECB - STBY PITOT HEAT (BATT Bus) or ECB - STBY PITOT HEAT (L FWD)
 - ECB - L WINDSHIELD HEAT (L AFT Bus)
 - ECB - R WINDSHIELD HEAT (R AFT Bus)
- (2) Power down the aircraft by setting the SYS BATT and START BATT switches to OFF and the BUS TIE switch to OPEN.
- (3) Disconnect WOW Box from aircraft. Refer to AMM-20-00-04-051-801 – Weight On Wheels (WOW) Box - Connect/Disconnect.
- B. Remove the external power from the aircraft. Refer to [AMM-24-40-00-051-801 – External Power - Maintenance Practices](#).
- C. Remove all tools, equipment and unwanted material from work area.
- D. If all other maintenance is complete, return aircraft to service. Refer to [AMM-20-00-02-051-801 – Return To Service \(After Maintenance\)](#).

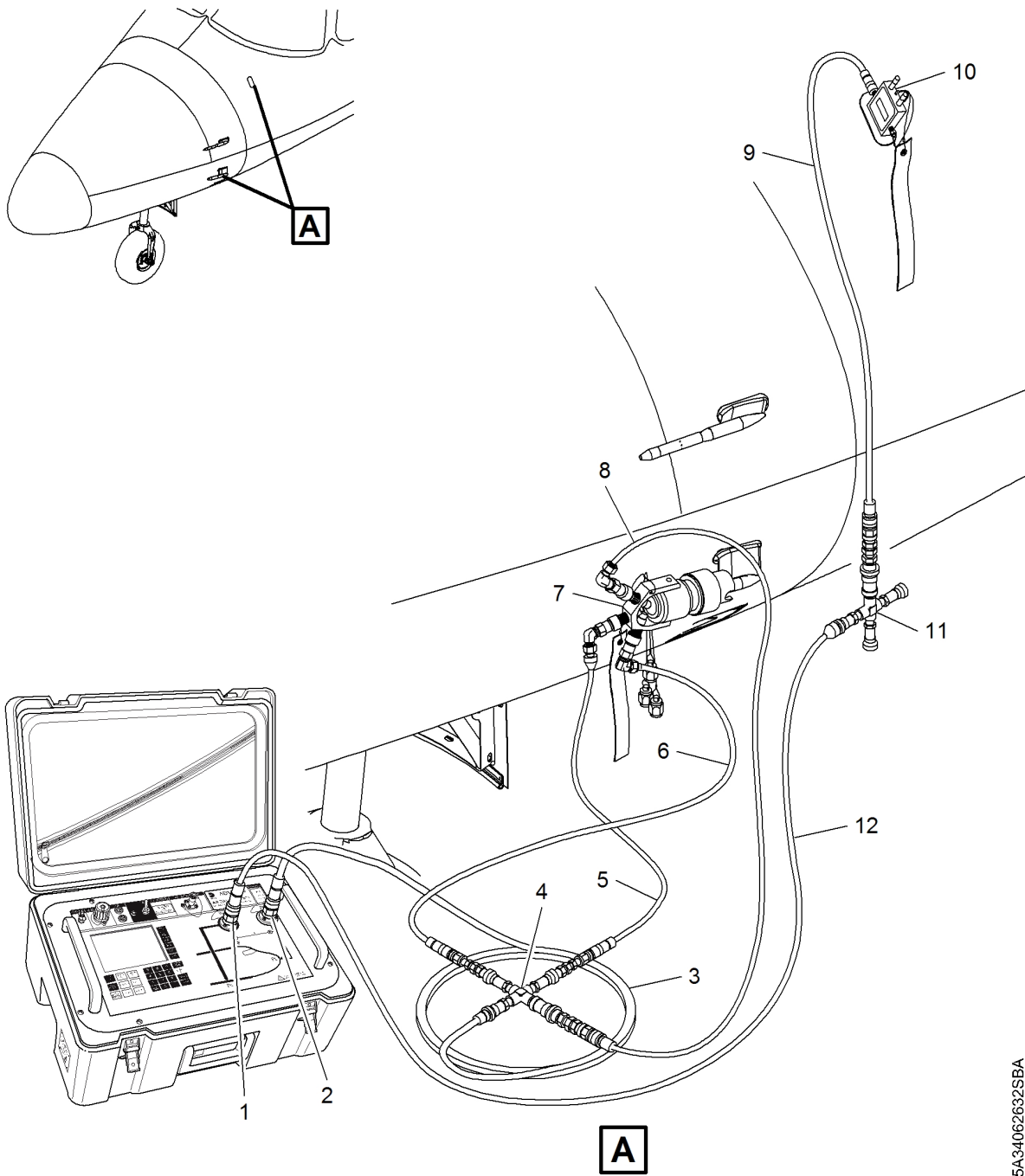

5A34062632SBA

Left Pitot/Static Hose Configuration (Three Port Adapter)
Figure 501 (Sheet 1 of 1)

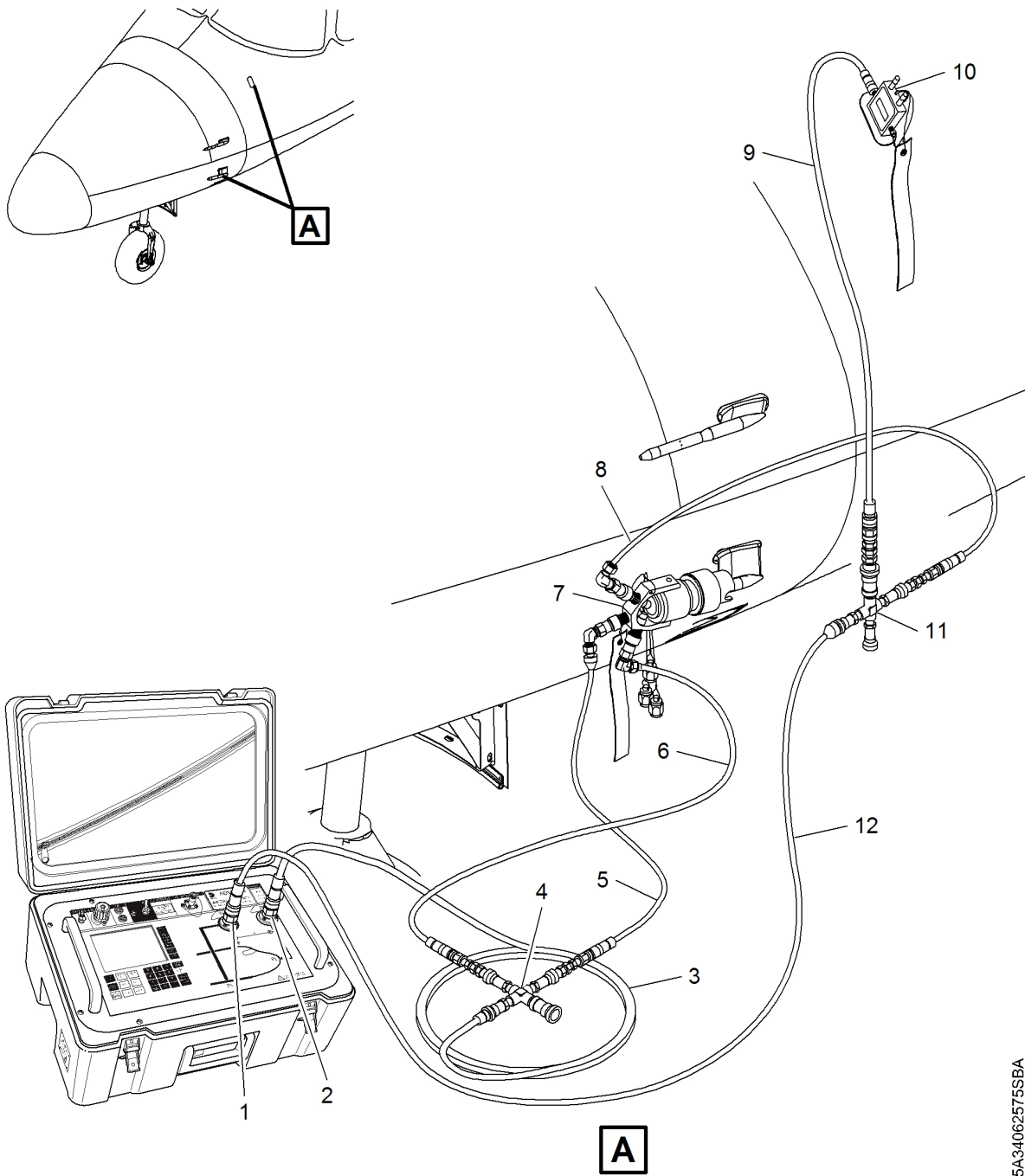

5A34062575SBA

**Left Angle of Attack Hose Configuration
Figure 502 (Sheet 1 of 1)**

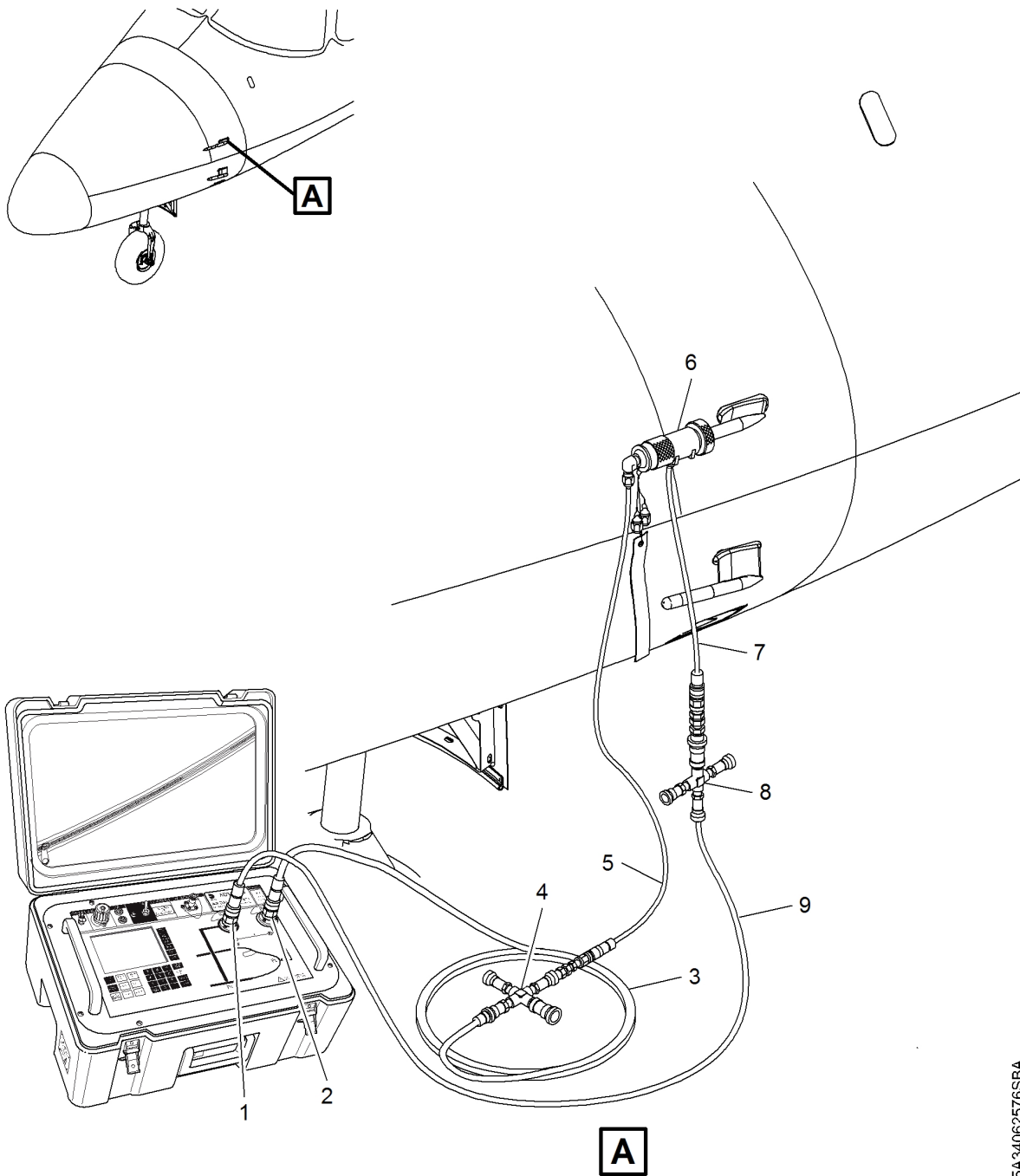

Standby Pitot/Static Test Adaptor Connections
Figure 503 (Sheet 1 of 1)

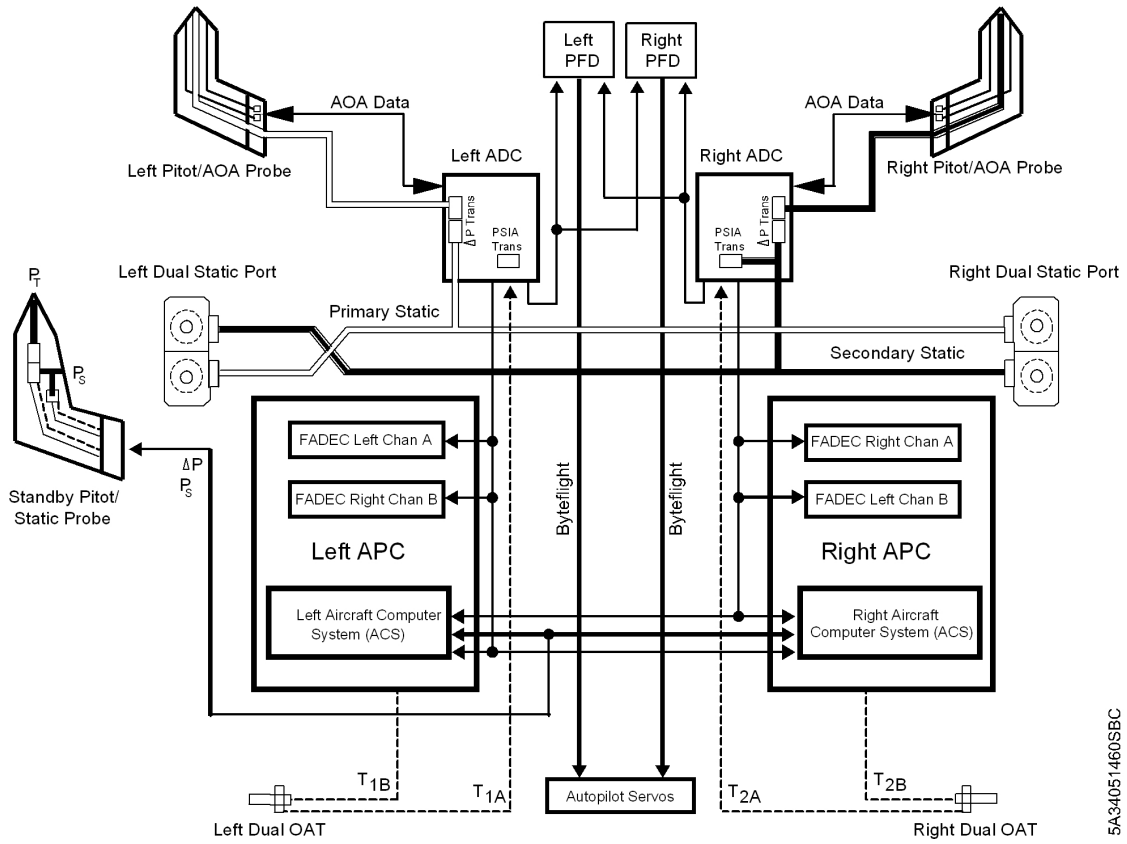

5A34051460SBC

**Air Data System Block Diagram
Figure 504 (Sheet 1 of 1)**