CHAPTER - 21 HIGHLIGHTS
(Summary of Changes)*Revision No. TR21-3 Oct 29/19*

TO: HOLDERS OF THE AIRCRAFT MAINTENANCE MANUAL (06-123838)

Pages that have been added or revised are summarized below. Remove and insert the affected pages as listed, and enter the above revision number with issue date into the Record of Revisions sheet.

This Temporary Revision incorporates and supersedes previously released temporary revisions for the chapters listed below.

Do not remove this page. Keep it in place as a record of previous changes.

CH/SE/SU Page Block No.	Description of Change
21-40-01 PgBlk 501	Updated BASS Components – Adjustment Test, Flow Control Valve (FCV) and Electronic Circuit Breaker (ECB) Verification and Figures 504 and 505.

THIS PAGE INTENTIONALLY LEFT BLANK

BASS COMPONENTS - ADJUSTMENT/TEST

AMM-21-40-01-071-801

1. General

- A. This task gives procedure to do an adjustment/test of the BASS Components.
- B. The Bleed Air Supply System (BASS) consists of the Flow Control Valve (FCV), Ram Air Flapper Doors (RAFD) and Fan Air Control Valve (FACV), located in the left and right engine pylons.

Table 501. Component Test Matrix

Component	Tests
Left and Right Pylon Leak Detectors	<i>BASS Leak Detection</i> SUBTASK AMM-21-40-01-071-791-002 .
Left and Right Primary Overheat Protection Sensor	<i>Primary Overheat Protection Sensor Test</i> SUBTASK AMM-21-40-01-071-751-003
Flow Control Valve	<i>Flow Control Valve (FCV) and Electronic Circuit Breaker (ECB) Verification</i> SUBTASK AMM-21-40-01-071-751-004
Flow Control Valve	<i>Flow Control Valve (FCV) Audible Test</i> SUBTASK AMM-21-40-01-071-751-005
Variable Outlet Ram Exhaust	<i>Variable Outlet Ram Exhaust (VORE) Test</i> SUBTASK AMM-21-40-01-071-751-006
Left Fan Air Control Valve	<i>Left Fan Air Control Valve (FACV) Test</i> SUBTASK AMM-21-40-01-071-751-007
Right Fan Air Control Valve	<i>Right Fan Air Control Valve (FACV) Test</i> SUBTASK AMM-21-40-01-071-751-008

2. Equipment and Materials

Table 502. Special Tools and Equipment:

Name and Part Number
Avio Maintenance Computer (AMC) (EAI 20-120576-1001 or 20-121926-1001), SW version 2.5.00 or higher
USB-to-Ethernet Adapter (SMC2209) [1]
10 Foot Ethernet Crossover Cable (EAI, PN 87-120877-1001) or 25 Foot Ethernet Crossover Cable (EAI, PN 87-120878-1001) [1]
Variable Heat Gun (Raychem AA-400)

[1] If AMC is used.

3. Job Set-Up

SUBTASK AMM-21-40-01-071-921-001

- A. Make aircraft safe for maintenance. Refer to [AMM-20-00-01-051-801 – Make Safe For Maintenance](#).
- B. Remove the left BASS NACA assembly 311 FL - NACA. Refer to [AMM-21-40-18-001-801 – NACA Duct - Removal](#).
- C. Remove the right BASS NACA assembly 312 CR - NACA. Refer to [AMM-21-40-18-001-801 – NACA Duct - Removal](#).
- D. Remove the 311 AL - Maintenance Bay Panel. Refer to [AMM-53-40-10-001-801 – Maintenance Bay Panel - Removal](#).
- E. Connect the Aircraft Maintenance Computer (AMC). Refer to [AMM-20-00-04-051-801 – Weight On Wheels \(WOW\) Box - Connect/Disconnect](#). – AMC Method.
- F. Prepare the anti-ice system for maintenance. Refer to [AMM-20-00-03-051-801 – Prepare Anti-Ice Systems For Maintenance](#).

4. **BASS Leak Detection**

SUBTASK AMM-21-40-01-071-791-002

(Refer to [Fig. 501](#).)

A. Do BASS leak detection as follows:

NOTE: Test procedure is same for both but given for left side.

- (1) With electrical power off, remove left BASS leak detection sensor(s) (2) from left BASS Module(s) (1) and allow sensor(s) to hang freely.
- (2) Power up the aircraft by switching the SYS BATT and START BATT to ON and the BUS TIE to AUTO.
- (3) On the MFD, scroll to PRESS synoptic page.

NOTE: If aircraft is on jacks, use AMC WOW function (Tab 32) to set Weight-on Wheels (WOnW button).
- (4) Use Variable Heat Gun to apply heat across the tip of removed BASS leak detection sensor(s) (2) with a waving motion.

NOTE: Do not exceed 200° C when heating the BASS leak detection sensor.
- (5) Observe the MFD PRESS synoptic page for a pylon temperature increase.
 - The pylon temperature indication will turn RED at 177° +/- 10° C.
 - CAS WARNING: L PYLON OVERHEAT will illuminate.
- (6) Remove heat from BASS leak detection sensor (2) .
- (7) Allow leak detection sensor to cool.
- (8) Observe the MFD PRESS synoptic page for a pylon temperature decrease.
 - On MFD PRESS synoptic page, the left pylon air temperature indication will turn back to WHITE.
 - CAS WARNING: L PYLON OVERHEAT message is extinguished.
- (9) Power down the aircraft by switching the SYS BATT and START BATT to OFF and the BUS TIE to OPEN.
- (10) Reinstall left BASS leak detection sensor (2) in BASS module (1) .

5. Primary Overheat Protection Sensor Test

SUBTASK AMM-21-40-01-071-751-003

(Refer to [Fig. 502.](#))

A. Do Primary Overheat Protection Sensor Test as follows:

NOTE: Test procedure is same for both but given for left side.

NOTE: If aircraft is on jacks, use AMC WOW function (Tab 32) to set Weight-on Wheels (WOnW button).

- (1) With NO power applied to the A/C, remove the left Primary Overheat Protection Sensor from the left muffler in the aft maintenance bay.
- (2) Power up the aircraft by switching the SYS BATT and START BATT to ON, and the BUS TIE to AUTO.
- (3) On the MFD, scroll to the PRESS synoptic page.
- (4) On Instrument Panel Left (IPL), select AIR SOURCE switch to NORM.
- (5) Use Variable Heat Gun to apply heat across the tip of removed left Primary Overheat Protection Sensor with a waving motion.

NOTE: Do not exceed 150° C when heating the left Primary Overheat Protection Sensor.

- (6) Observe the Flow Control Valve (FCV) and bleed air temperature indication on the MFD PRESS synoptic page.
 - Temperature indication transitions from WHITE to RED.
 - CAS ADVISORY: L BLEED AIR TEMP HIGH illuminates at 85° +/-5° C.
 - Make sure that the audible click of the left FCV solenoid is heard at 85° +/-5° C.
 - CAS WARNING: L BLEED AIR OVERHEAT illuminates at 100° +/-10° C.
- (7) Remove the heat source and allow the left Primary Overheat Protection Sensor to cool.
- (8) Observe the FCV and bleed air temperature indication on the MFD PRESS synoptic page as left Primary Overheat Protection Sensor cools.
 - Left bleed air temperature indication returns to WHITE.
 - FCV audible “click” is heard.
 - CAS messages extinguish.
- (9) Power down the aircraft by switching the SYS BATT and START BATT to OFF and the BUS TIE to OPEN.
- (10) With NO power applied to the aircraft, re-install the left Primary Overheat Protection Sensor into the left muffler.
- (11) Repeat test procedure for right BASS leak detection sensor if required.

6. Flow Control Valve (FCV) and Electronic Circuit Breaker (ECB) Verification

SUBTASK AMM-21-40-01-071-751-004

A. FCV CAS and ECB Verification

For maintenance convenience the VORE Test can be done using the WOW function on the AMC.

- (1) Power up the aircraft by switching the SYS BATT and START BATT to ON, and the BUS TIE to AUTO.
- (2) Clear any MASTER CAUTIONS and MASTER WARNINGS as needed.
- (3) On the left PFD, right PFD and MFD do the following:
 - Scroll to the OPS page on the MFD. Select SYSTEM TEST.
 - Select A/C MAINT Mode ON.
- (4) On the 21 AIR COND tab, select L BASS CAL. Refer to [Fig. 504, Sheet 1](#).
- (5) Press OVRD ENGINES button, then press the Engine OFF button to simulate turning the engine on.
- (6) Make sure that the Engine OFF button changes to Engine ON.
- (7) Set the AMC to WOffW.
- (8) On the IPL, select AIR SOURCE switch to OFF.
- (9) Observe MFD PRESS synoptic page display, specifically the FCV symbol.
 - LH FCV: WHITE
 - RH FCV: WHITE
- (10) Make sure that NO L/R BLEED VALVE FAIL messages are shown.
- (11) On the IPL, turn the AIR SOURCE switch, with a momentary pause at each setting as follows:
 - OFF to L
 - L to NORM
 - NORM to R
 - R to OFF

-
- B. Observe MFD PRESS synoptic page display, specifically the FCV symbol.
- OFF to L: RH FCV CLOSED/LH FCV OPEN
 - L to NORM: Both FCV OPEN
 - NORM to R: LH FCV CLOSED/RH FCV OPEN
 - R to OFF: Both FCV CLOSED
- C. On the MFD ECB synoptic page, select ECB BY SYSTEM then select PRESS and scroll to ECB selections as follows:
- L ENG BLEED VALVE
 - L ENG BLEED FLOW HI/LO
 - R ENG BLEED VALVE
 - R ENG BLEED FLOW HI/LO
- D. On the IPL, make sure that the AIR SOURCE switch is OFF.
- E. Observe MFD ECB page display and make sure of the ECB AUTO state.
- L ENG BLEED VALVE: AUTO ON
 - L ENG BLEED FLOW HI/LO: AUTO OFF
 - R ENG BLEED VALVE: AUTO ON
 - R ENG BLEED FLOW HI/LO: AUTO OFF
- F. Press Engine OFF button to simulate turning the engine off.
- G. On the 21 AIR COND tab, select R BASS CAL. Refer to [Fig. 505, Sheet 1](#).
- H. Press OVRD ENGINES button, then press the Engine OFF button to simulate turning the engine on.
- I. Make sure that the Engine OFF button changes to Engine ON.
- J. On the IPL, select AIR SOURCE switch to L. Observe MFD ECB synoptic page display and make sure of the ECB AUTO state.
- L ENG BLEED VALVE: AUTO OFF
 - L ENG BLEED FLOW HI/LO: AUTO ON
 - R ENG BLEED VALVE: AUTO ON
 - R ENG BLEED FLOW HI/LO: AUTO OFF
- K. On the IPL, select AIR SOURCE switch to NORM.

- L. Observe MFD ECB synoptic page display and make sure of the ECB AUTO state.
 - L ENG BLEED VALVE: AUTO OFF
 - L ENG BLEED FLOW HI/LO: AUTO OFF
 - R ENG BLEED VALVE: AUTO OFF
 - R ENG BLEED FLOW HI/LO: AUTO OFF
- M. On the IPL, select AIR SOURCE switch to R. Observe MFD ECB synoptic page display and make sure of the ECB AUTO state.
 - L ENG BLEED VALVE: AUTO ON
 - L ENG BLEED FLOW HI/LO: AUTO OFF
 - R ENG BLEED VALVE: AUTO OFF
 - R ENG BLEED FLOW HI/LO: AUTO ON
- N. On the IPL, make sure that the AIR SOURCE switch is OFF.
- O. Observe MFD ECB page display and make sure of the ECB AUTO state.
 - L ENG BLEED VALVE: AUTO ON
 - L ENG BLEED FLOW HI/LO: AUTO OFF
 - R ENG BLEED VALVE: AUTO ON
 - R ENG BLEED FLOW HI/LO: AUTO OFF
- P. Press the Engine OFF button to simulate turning the engine off.
- Q. Set the AMC to WOnW.
- R. On the left PFD, right PFD and MFD do the following:
 - Scroll to the OPS page on the MFD. Select SYSTEM TEST.
 - Select A/C MAINT Mode OFF.
- S. Power down the aircraft by switching the SYS BATT and START BATT to OFF and the BUS TIE to OPEN.

7. Flow Control Valve (FCV) Audible Test

SUBTASK AMM-21-40-01-071-751-005

A. FCV Audible Test

- (1) Do the FCV Test using the AMC.
- (2) Power up the aircraft by switching the SYS BATT and START BATT to ON, and the BUS TIE to AUTO.
- (3) Clear any MASTER CAUTIONS and MASTER WARNINGS as needed.
- (4) Set the AMC to WOffW.

- (5) On the IPL, select AIR SOURCE switch to OFF. Observe MFD PRESS synoptic page display.
 - LH FCV: OFF
 - RH FCV: OFF
- (6) With the left and right BASS NACA assembly removed, view the left and right FCV from the top of the pylon.
- (7) On the IPL, select AIR SOURCE switch to L and listen for an audible click of the left FCV solenoid.
- (8) On the IPL, select AIR SOURCE switch to NORM and listen for an audible click of the right FCV solenoid.
- (9) On the IPL, select Air Source switch R and listen for audible click of the left FCV solenoid.
- (10) On the IPL, select AIR SOURCE switch to OFF and listen for an audible click of the right FCV solenoid.
- (11) Observe MFD PRESS synoptic page display.
 - LH FCV: OFF
 - RH FCV: OFF
- (12) Set the AMC to WOnW.
- (13) Power down the aircraft by switching the SYS BATT and START BATT to OFF and the BUS TIE to OPEN.

8. Variable Outlet Ram Exhaust (VORE) Test

SUBTASK AMM-21-40-01-071-751-006

A. Do the VORE Test using the AMC.

- (1) Power up the aircraft by switching the SYS BATT and START BATT to ON, and the BUS TIE to AUTO.
- (2) Clear any MASTER CAUTIONS and MASTER WARNINGS as needed.
- (3) View the left and right VORE through the installed lower pylon heat exchanger exhaust louvers and set the AMC to WOnW on ground.
- (4) Make sure that the left and right VORE are in the CLOSED position or move to the CLOSED position.
- (5) View the left and right VORE through the installed lower pylon heat exchanger exhaust louvers and set the AMC to WOffW in air.
- (6) Make sure that the left and right VORE move to the OPEN position.
- (7) View the left and right VORE through the installed lower pylon heat exchanger exhaust louvers and set the AMC to WOnW on ground.
- (8) Make sure that the left and right VORE move to the CLOSED position.
- (9) Make sure that no CLIMATE CTRL FAIL CAS messages are illuminated.

-
- (10) Power down the aircraft by switching the SYS BATT and START BATT to OFF and the BUS TIE to OPEN.

9. **Left Fan Air Control Valve (FACV) Test**

SUBTASK AMM-21-40-01-071-751-007

A. Do the left FACV Test using the AMC.

- (1) Power up the aircraft by switching the SYS BATT and START BATT to ON, and the BUS TIE to AUTO.
- (2) On the left PFD, right PFD and MFD do the following:
 - Scroll to the OPS page on the MFD. Select SYSTEM TEST.
 - Select A/C MAINT Mode ON.
 - Clear any MASTER CAUTIONS and MASTER WARNINGS.
- (3) On the 21 AIR COND tab, select L BASS CAL. Refer to [Fig. 504, Sheet 1](#).
- (4) Press OVRD ENGINES button, then press the Engine OFF button to simulate turning the engine on.
- (5) Make sure that the Engine OFF button changes to Engine ON.
- (6) View the left and right FACV from the top of the pylon.
- (7) Select the AIR SOURCE switch to OFF.
- (8) Make sure that the left and right FACV are in the CLOSED position or move to the CLOSED position.
- (9) Select the AIR SOURCE switch to L.
- (10) Make sure that the left FACV moves to the OPEN position and the right FACV remains in the CLOSED position.
- (11) Select the AIR SOURCE switch to NORM.
- (12) Make sure that the left FACV remains in the OPEN position and the right FACV moves to the OPEN position.
- (13) Select the AIR SOURCE switch to R.
- (14) Make sure that the left FACV moves to the CLOSED position and the right FACV remains in the OPEN position.
- (15) Select the AIR SOURCE switch to OFF.
- (16) Make sure that the left FACV remains in the CLOSED position and the right FACV moves to the CLOSED position.
- (17) Make sure that no CLIMATE CTRL FAIL CAS messages have illuminated.
- (18) Press the Engine OFF button to simulate turning the engine off.
- (19) Select the Done button on the AMC.
- (20) Power down the aircraft by switching the SYS BATT and START BATT to OFF and the BUS TIE to OPEN.

10. Right Fan Air Control Valve (FACV) Test

SUBTASK AMM-21-40-01-071-751-008

- A. Do the right FACV Test using the AMC.
- (1) Power up the aircraft by switching the SYS BATT and START BATT to ON, and the BUS TIE to AUTO.
 - (2) On the left PFD, right PFD and MFD do the following:
 - Scroll to the OPS page on the MFD. Select SYSTEM TEST.
 - Select A/C MAINT Mode ON.
 - Clear any MASTER CAUTIONS and MASTER WARNINGS.
 - (3) On the 21 AIR COND tab, select R BASS CAL. Refer to [Fig. 505, Sheet 1](#).
 - (4) Press OVRD ENGINES button, then press the ENGINE OFF button to simulate turning the engine on.
 - (5) Make sure that the Engine OFF button changes to Engine ON.
 - (6) View the left and right FACV from the top of the pylon.
 - (7) Select the AIR SOURCE switch to OFF.
 - (8) Make sure that the right and left FACV are in the CLOSED position or move to the CLOSED position.
 - (9) Select the AIR SOURCE switch to L.
 - (10) Make sure that the right FACV remains in the CLOSED position and the left FACV moves to the OPEN position.
 - (11) Select the AIR SOURCE switch to NORM.
 - (12) Make sure that the right FACV moves to the OPEN position and the left FACV remains in the OPEN position.
 - (13) Select the AIR SOURCE switch to R.
 - (14) Make sure that the right FACV remains in the OPEN position and the left FACV moves to the CLOSED position.
 - (15) Select the AIR SOURCE switch to OFF.
 - (16) Make sure that the right FACV moves to the CLOSED position and the left FACV remains in the CLOSED position.
 - (17) Make sure that no CLIMATE CTRL FAIL CAS messages have illuminated.
 - (18) Press the Engine OFF button to simulate turning the engine off.
 - (19) Select the Done button on the AMC.
 - (20) Power down the aircraft by switching the SYS BATT and START BATT to OFF and the BUS TIE to OPEN.

11. Job Close-Up

SUBTASK AMM-21-40-01-071-921-009

- A. Remove all tools, equipment and unwanted material from work area.
- B. Install the left BASS NACA assembly 311 FL - NACA. Refer to [AMM-21-40-18-041-801 – NACA Duct - Installation](#) .
- C. Install the right BASS NACA assembly 312 CR - NACA. Refer to [AMM-21-40-18-041-801 – NACA Duct - Installation](#) .
- D. Install the 311 AL - Maintenance Bay Panel. Refer to [AMM-53-40-10-041-801 – Maintenance Bay Panel - Installation](#).
- E. Return the anti-ice systems to service after maintenance is complete. Refer to [AMM-20-00-03-051-801 – Prepare Anti-Ice Systems For Maintenance](#).
- F. Disconnect the AMC. Refer to [AMM-20-00-04-051-801 – Weight On Wheels \(WOW\) Box - Connect/Disconnect](#) .
- G. If all other maintenance is complete, return aircraft to service. Refer to [AMM-20-00-02-051-801 – Return To Service \(After Maintenance\)](#) .

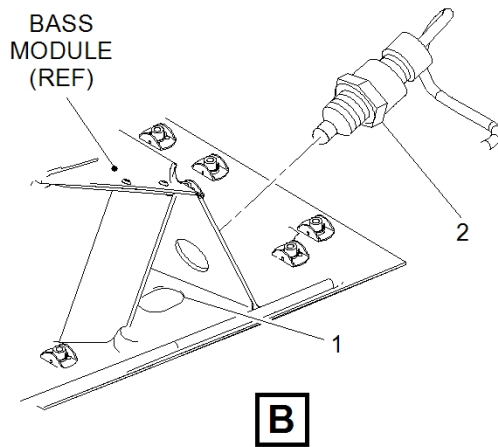
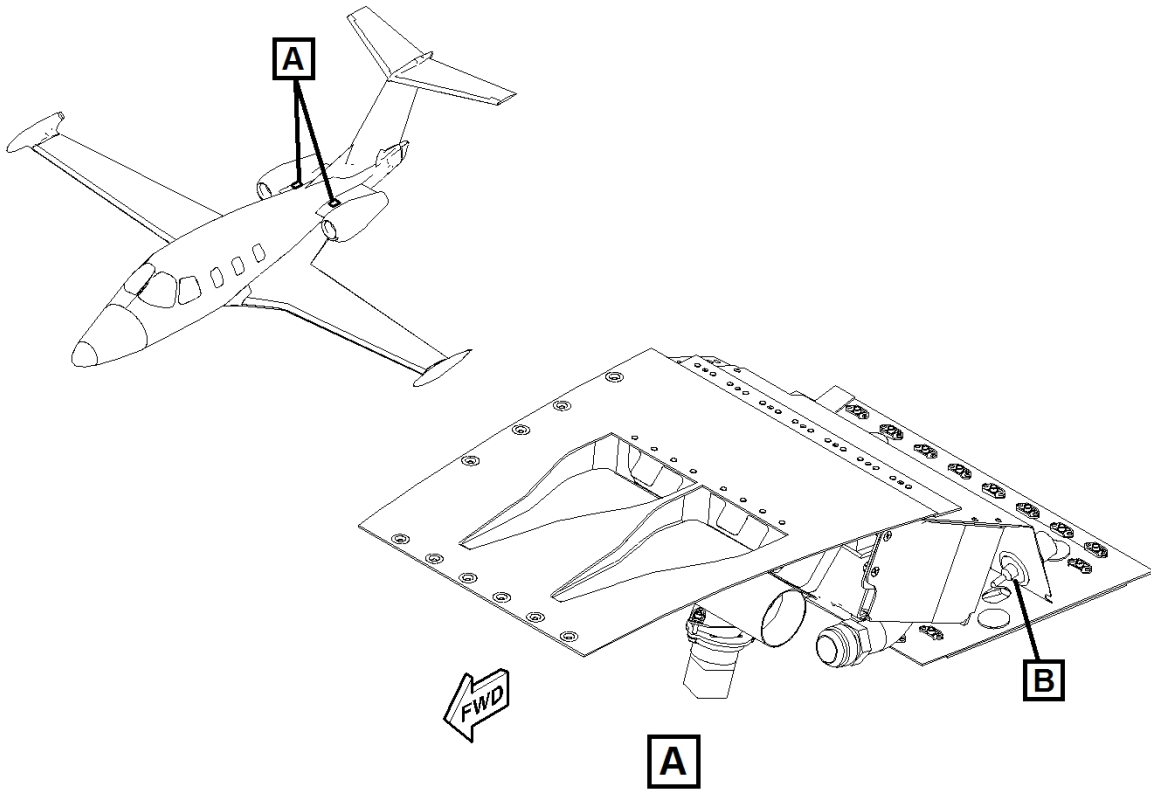

5A21061401SBB

BASS Leak Detectors
Figure 501 (Sheet 1 of 1)

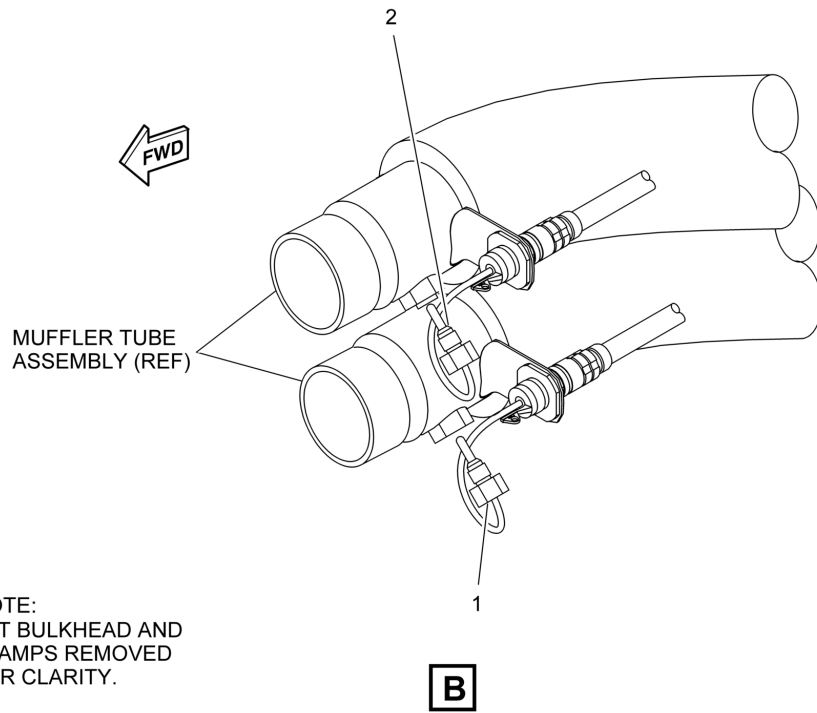
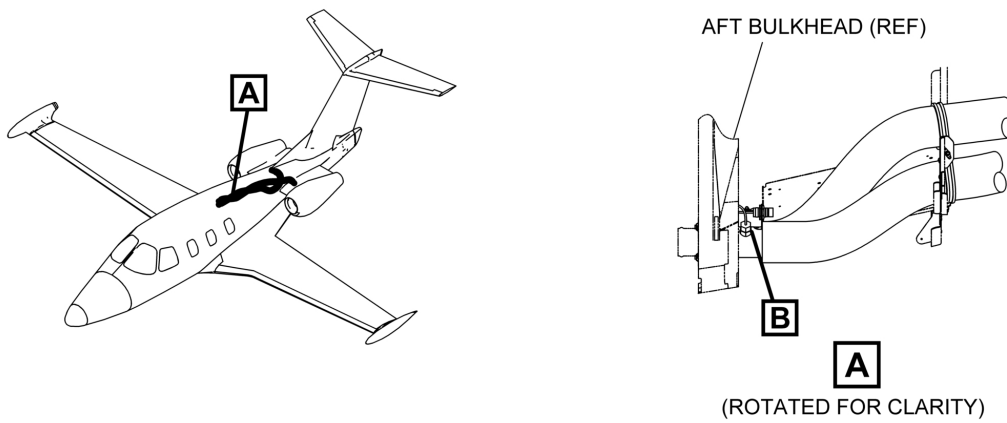

NOTE:
AFT BULKHEAD AND
CLAMPS REMOVED
FOR CLARITY.

5A21061402SBA

Primary Overheat Protection Sensor
Figure 502 (Sheet 1 of 1)

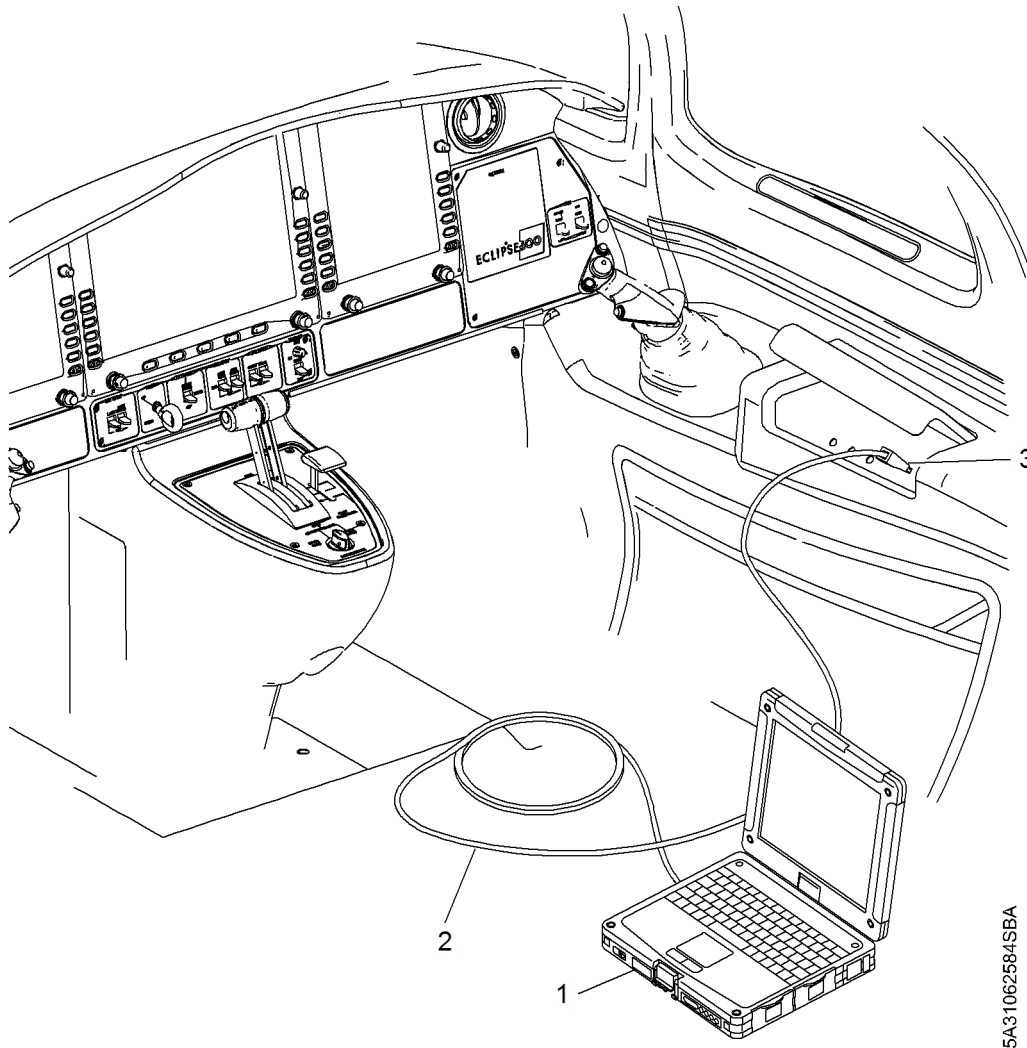

5A3106258-4SBA

**AMC - Co-Pilot's Armrest USB Port Connection
Figure 503 (Sheet 1 of 1)**

AVIO Maintenance Computer

Oct 25 16:12:19 UTC X
Version AMC_2.5.10 © Eclipse Aerospace

30 Ice Prot	31 Instr	32 Ldg Gear		34 Nav/Pitot		73 Fuel Ctrl
8 Weigh	21 Air Cond	22 Auto Pilot	23 Com	24 Elec	27 Flt Ctrls	28 Fuel

Left BASS Cals ▼

Left Actuator Cals

Start
OvRd Engine Off
OvRd WOnW

Closed
VORE Door
Open

Default
◀◀
◀
▶
▶▶
Default

Closed
FACV Door
Open

Default
◀◀
◀
▶
▶▶
Default

Batt: AC

DSU App

L-ACS

R-ACS

5A21062618SCD

Left BASS Cals
Figure 504 (Sheet 1 of 1)

AVIO Maintenance Computer

Oct 25 16:12:28 UTC X
Version AMC_2.5.10 © Eclipse Aerospace

30 Ice Prot	31 Instr	32 Ldg Gear		34 Nav/Pitot		73 Fuel Ctrl
8 Weigh	21 Air Cond	22 Auto Pilot	23 Com	24 Elec	27 Flt Ctrls	28 Fuel

Right BASS Cals ▾

Right Actuator Cals

Start
OvRd Engine Off
OvRd WOnW

Closed VORE Door Open

Closed FACV Door Open

Batt: AC

DSU
App

L-ACS

R-ACS

5A21062831SCD

Right BASS Cals
Figure 505 (Sheet 1 of 1)