

**CHAPTER - 30 HIGHLIGHTS**  
**(Summary of Changes)**

*Revision No. TR30-4 Sep 12/17*

TO: HOLDERS OF THE AIRCRAFT MAINTENANCE MANUAL (06-123838)

Pages that have been added or revised are summarized below. Remove and insert the affected pages as listed, and enter the above revision number with issue date into the Record of Revisions sheet.

**This Temporary Revision incorporates and supersedes previously released temporary revisions for the chapters listed below.**

*Do not remove this page. Keep it in place as a record of previous changes.*

<b>CH/SE/SU Page Block No.</b>	<b>Description of Change</b>
30-00-00 PgBlk 501 (A)	Added configuration - Adjustment/Test — Config A.
30-00-00 PgBlk 501 (B)	Added Pitot/AOA Probe Auxiliary Heaters Adjustment/Test. — Config B.
30-30-00 PgBlk 501 (C)	Added Pitot/AOA Probe Auxiliary Heaters Adjustment/Test procedure. — Config C.
30-30-00 PgBlk 1 (A)	Added configuration to description and operation — Config A.
30-30-00 PgBlk 1 (B)	Added Pitot/AOA Probe Auxiliary Heaters to description and operation. — Config B.
30-30-10 PgBlk 401-Rem	Added task Pitot/AOA Probe Auxiliary Heater - Removal to AMM.
30-30-10 PgBlk 401-Inst	Added Pitot/AOA Probe Auxiliary Heater - Installation to AMM.

THIS PAGE INTENTIONALLY LEFT BLANK

---

**ICE PROTECTION - ADJUSTMENT/TEST**

AMM-30-00-00-071-A-801

**1. General**

- A. This task gives the procedure to do a general test of the ice protection systems. Pitot/AOA probes and static ports anti-ice test and windshield heat test can be done as subsystem tests.
- B. For complete ice and rain protection subsystem adjustment/tests, refer to the systems that follow:
- Airfoil Deice System. Refer to [AMM-30-10-10-071-801 – Airfoil Deice System - Adjustment/Test](#).
  - Engine Inlet Anti-Ice. Refer to [AMM-30-20-10-071-801 – Engine Inlet Anti-Ice - Adjustment/Test](#).
  - Pitot/Angle of Attack (AOA) and Pitot/Static Heat System. Refer to [AMM-30-30-00-071-801 – Pitot and Static Anti-Ice System - Adjustment/Test](#).
  - Windshield Heat. Refer to [AMM-30-40-00-071-801 – Windshield Heat System - Adjustment/Test](#).

THIS PAGE INTENTIONALLY LEFT BLANK

---

**ICE PROTECTION - ADJUSTMENT/TEST**

AMM-30-00-00-071-B-801

**1. General**

- A. This task gives the procedure to do a general test of the ice protection systems. Pitot/AOA probes and static ports anti-ice test and windshield heat test can be done as subsystem tests.
- B. For complete ice and rain protection subsystem adjustment/tests, refer to the systems that follow:
- Airfoil Deice System. Refer to [AMM-30-10-10-071-801 – Airfoil Deice System - Adjustment/Test](#).
  - Engine Inlet Anti-Ice. Refer to [AMM-30-20-10-071-801 – Engine Inlet Anti-Ice - Adjustment/Test](#).
  - Pitot/Angle of Attack (AOA) and Pitot/Static Heat System. Refer to [AMM-30-30-00-071-C-801 – Pitot and Static Anti-Ice System - Adjustment/Test](#)
  - Pitot/Angle of Attack (AOA) Auxiliary Heater System. Refer to [AMM-30-30-00-071-C-801 – Pitot and Static Anti-Ice System - Adjustment/Test](#)
  - Windshield Heat. Refer to [AMM-30-40-00-071-801 – Windshield Heat System - Adjustment/Test](#).

THIS PAGE INTENTIONALLY LEFT BLANK

---

**PITOT AND STATIC ANTI-ICE SYSTEM - ADJUSTMENT/TEST**

AMM-30-30-00-071-C-801

**1. General**

- A. This task gives the steps to test the Static Ports, Pitot/AOA Probes, and the Standby Pitot/Static Probe anti-ice system.

**2. Job Set Up**

SUBTASK AMM-30-30-00-071-B-921-001

- A. Make aircraft safe for maintenance. Refer to [AMM-20-00-01-051-801 – Make Safe For Maintenance](#).
- B. Required Test Equipment
- Extech EX470 with Type K Adapter, or equivalent
  - Thermocouple:
    - SCASS-020G-12-SHX,
    - KMQSS-062G-6, or
    - SCAIN-062G-6–SHX, or
    - SCASS-062G-6-SHX, or
    - SCA321SS-062G-6–SHX
- C. Connect external power. Refer to [AMM-24-40-00-051-801 – External Power - Maintenance Practices](#).

**3. Procedure**

SUBTASK AMM-30-30-00-071-B-701-001

**A. Test Set Up:**

**NOTE:** STALL PROTECTION FAIL CAS messages are displayed throughout test due to ECBs being pulled. Respective system CAS messages are displayed when their ECBs are pulled.

**NOTE:** This test is easier to perform with two Extech EX470, but can be done using just one. Instructions are provided for either method.

- (1) Power up the aircraft by setting the SYS BATT and START BATT switches to ON and the BUS TIE to AUTO. (Clear any MASTER WARNINGS/CAUTIONS as needed.)
- (2) Ensure aircraft's WOW state is weight on wheels while performing the Anti-ice System Test. If the aircraft is on jacks utilize the [AMM-20-00-04-051-801 – Weight On Wheels \(WOW\) Box - Connect/Disconnect](#) procedure to set the aircraft to weight on wheels.
- (3) Using left/right lower knob on MFD, scroll to the ECB synoptic page. Press the ECB BY SYSTEM Line Select Key (LSK) and using outer knob scroll to ICE PROT, press the inner knob to select. Using outer knob scroll to select ECB and press the PULL LSK for the following ECBs:
  - ECB - DEICE MANIFOLD HTR (R AFT Bus)
  - ECB - L PITOT HEAT (L FWD Bus)
  - ECB - R PITOT HEAT (R FWD Bus)
  - ECB - L STATIC HEAT (BATT Bus)
  - ECB - L STATIC HEAT (R FWD Bus)
  - ECB - R STATIC HEAT (L FWD Bus)
  - ECB - R STATIC HEAT (R FWD Bus)
  - ECB - STBY PITOT HEAT (BATT Bus)
  - ECB - L WINDSHIELD HEAT (L AFT Bus)
  - ECB - R WINDSHIELD HEAT (R AFT Bus)

**CAUTION:** DURING THIS TEST, THE HEATERS WILL BE COMMANDED ON BY THE SYSTEM. RH AND LH PITOT/AOA PROBES WILL HEAT UP TO APPROXIMATELY 550°C AND THE STANDBY PITOT/STATIC PROBE WILL HEAT UP TO APPROXIMATELY 400°C. HARM TO PERSONNEL OR EQUIPMENT CAN OCCUR IF TOUCHING THE PROBES. DO NOT LEAVE ON FOR EXTENDED TIME. ALLOW 10 MINUTES AFTER TEST FOR PROBES TO COOL.

- (4) Record the current ambient temperature within a 5 ft. radius of the nose of the aircraft using a Extech EX470, or equivalent, in conjunction with a SCASS-062G-6-SHX or SCASS-020G-12-SHX thermocouple.

**B. Left Static Port Test:**

- (1) On MFD, scroll to the ICE synoptic page using the lower left/right knob.  
Press the PITOT/STATIC LSK to select ON.
- (2) **ECB - L STATIC HEAT (BATT Bus)**
  - (a) Using left/right lower knob on MFD, scroll to the ECB synoptic page.  
Press the ECB BY SYSTEM LSK and using outer knob scroll to ICE PROT,  
press the inner knob to select.  
Using outer knob, scroll to ECB - L STATIC HEAT (BATT Bus) and press the  
RESET LSK.
  - (b) Using a SCASS-062G-6-SHX Thermocouple Thermometer, measure the  
temperature in center hole of top static port of the left static port. (Insert  
thermocouple until resistance is felt against back wall of hole.)
    - Verify the static port temperature is 12°C greater than ambient and rising  
within a four minute period.
  - (c) Using left/right lower knob on MFD, scroll to the ECB synoptic page.  
Press the ECB BY SYSTEM LSK and using outer knob scroll to ICE PROT,  
press the inner knob to select.  
Using outer knob, scroll to ECB - L STATIC HEAT (BATT Bus) and press the  
PULL LSK.
- (3) Allow time for the static port to cool before testing the next ECB (approximately 10  
minutes).
- (4) **ECB - L STATIC HEAT (R FWD Bus)**
  - (a) Using left/right lower knob on MFD, scroll to the ECB synoptic page.  
Press the ECB BY SYSTEM LSK and using outer knob scroll to ICE PROT,  
press the inner knob to select.  
Using outer knob, scroll to ECB - L STATIC HEAT (R FWD Bus) and press the  
RESET LSK.
  - (b) Using a SCASS-062G-6-SHX Thermocouple Thermometer, measure the  
temperature in center hole of top static port of the left static port. (Insert  
thermocouple until resistance is felt against back wall of hole.)
    - Verify the static port temperature is 12°C greater than ambient and rising  
within a four minute period.
  - (c) Using left/right lower knob on MFD, scroll to the ECB synoptic page.  
Press the ECB BY SYSTEM LSK and using outer knob scroll to ICE PROT,  
press the inner knob to select.  
Using outer knob, scroll to ECB - L STATIC HEAT (R FWD Bus) and press the  
PULL LSK.

---

**C. Right Static Port Test:**

- (1) On MFD, scroll to the ICE synoptic page using the lower left/right knob.  
Press the PITOT/STATIC LSK to select ON.
- (2) **ECB - R STATIC HEAT (L FWD Bus)**
  - (a) Using left/right lower knob on MFD, scroll to the ECB synoptic page.  
Press the ECB BY SYSTEM LSK and using outer knob scroll to ICE PROT,  
press the inner knob to select.  
Using outer knob, scroll to ECB - R STATIC HEAT (L FWD Bus) and press the  
RESET LSK.
  - (b) Using a SCASS-062G-6-SHX Thermocouple Thermometer, measure the  
temperature in center hole of top static port of the left static port. (Insert  
thermocouple until resistance is felt against back wall of hole.)
    - Verify the static port temperature is 12°C greater than ambient and rising  
within a four minute period.
  - (c) Using left/right lower knob on MFD, scroll to the ECB synoptic page.  
Press the ECB BY SYSTEM LSK and using outer knob scroll to ICE PROT,  
press the inner knob to select.  
Using outer knob, scroll to ECB - R STATIC HEAT (L FWD Bus) and press the  
PULL LSK.
- (3) Allow time for the static port to cool before testing the next ECB (approximately 10  
minutes).
- (4) **ECB - R STATIC HEAT (R FWD Bus)**
  - (a) Using left/right lower knob on MFD, scroll to the ECB synoptic page.  
Press the ECB BY SYSTEM LSK and using outer knob scroll to ICE PROT,  
press the inner knob to select.  
Using outer knob, scroll to ECB - R STATIC HEAT (R FWD Bus) and press the  
RESET LSK.
  - (b) Using a SCASS-062G-6-SHX Thermocouple Thermometer, measure the  
temperature in center hole of top static port of the left static port. (Insert  
thermocouple until resistance is felt against back wall of hole.)
    - Verify the static port temperature is 12°C greater than ambient and rising  
within a four minute period.
  - (c) Using left/right lower knob on MFD, scroll to the ECB synoptic page.  
Press the ECB BY SYSTEM LSK and using outer knob scroll to ICE PROT,  
press the inner knob to select.  
Using outer knob, scroll to ECB - R STATIC HEAT (R FWD Bus) and press the  
PULL LSK.

**D. LH Pitot/AOA Probe Test:**

(Refer to [Fig. 501](#) when recording test results.)

- (1) Insert the SCASS-020G-12-SHX thermocouple  $5.1 \pm 0.1$  inch into the upper AOA port (small hole on the upper surface of the tip) of the LH Pitot/AOA Probe.
- (2) Insert the SCASS-062G-6-SHX thermocouple  $0.5 \pm 0.1$  inch into the ram air port (larger port) of the LH Pitot/AOA Probe.
- (3) On the MFD:
  - (a) Scroll to the ICE synoptic page using the lower left/right knob and press the PITOT/STATIC LSK to select ON.
  - (b) Scroll to the ECB synoptic page using the left/right lower knob and press ECB BY SYSTEM LSK.
  - (c) Scroll to ICE PROT using the inner knob and press the inner knob to select.
  - (d) Scroll to the ECB — L PITOT HEAT (L FWD Bus) using the outer knob and press the RESET LSK.

**(4) If you are using two Extech EX470 or equivalent to measure the temperature:**

NOTE: Probe tip heat should be on for at least 5 minutes before power is removed, unless temperature exceeds  $550^{\circ}\text{C}$ .

- (a) Start timer and monitor the SCASS-020G-12-SHX and the SCASS-062G-6-SHX.
  1. Record peak temperature for the upper AOA (SCASS-020G-12-SHX). This should take no longer than two minutes and be a minimum of  $100^{\circ}\text{C}$ .
  2. Record peak temperature of the probe tip (SCASS-062G-6-SHX). This should take no longer than 5 minutes. If the probe heat should exceed  $550^{\circ}\text{C}$  within 5 minutes, PULL ECB – L PITOT HEAT (L FWD Bus).
  3. The probe tip temperature must reach a minimum of  $370^{\circ}\text{C}$  and not exceed  $550^{\circ}\text{C}$  within the 5 minutes.

- (5) **If you are using one Extech EX470 or equivalent, measure the ambient temperature in conjunction with a SCASS-020G-12-SHX thermocouple:**
- (a) Start the timer and monitor the upper AOA port using the Extech EX470 and SCASS-020G-12-SHX thermocouple.
    - 1. Record peak temperature. This should take no longer than two minutes and be a minimum of 100°C.

**NOTE:** Probe tip heat should be on for at least 5 minutes before power is removed, unless temperature exceeds 550°C.
  - (b) Once the upper AOA port peak temperature has been reached and recorded, unplug the SCASS-020G-12-SHX and immediately plug in SCASS-062G-6-SHX thermocouple.
    - 1. Record peak temperature of the probe tip (SCASS-062G-6-SHX). This should take no longer than 5 minutes. If the probe heat should exceeds 550°C within 5 minutes, PULL ECB – L PITOT HEAT (L FWD Bus).
    - 2. The probe tip temperature must reach a minimum of 370°C and not exceed 550°C within the 5 minutes.
- (6) Using left/right lower knob on MFD, scroll to the ECB synoptic page. Press ECB BY SYSTEM LSK and using inner knob scroll to ICE PROT. Press inner knob to select. Using outer knob, scroll to ECB - L PITOT HEAT (L FWD Bus) and press the PULL LSK.
- (a) Verify the “L PITOT HEAT FAIL” CAS message illuminates.

**E. RH Pitot/AOA Probe Test:**

(Refer to [Fig. 501](#) when recording test results.)

- (1) Insert the SCASS-020G-12-SHX thermocouple  $5.1 \pm 0.1$  inch into the upper AOA port (small hole on the upper surface of the tip) of the RH Pitot/AOA Probe.
- (2) Insert the SCASS-062G-6-SHX thermocouple  $0.5 \pm 0.1$  inch into the ram air port (larger port) of the RH Pitot/AOA Probe.
- (3) On the MFD:
  - (a) Scroll to the ECB synoptic page using the left/right lower knob and press ECB BY SYSTEM LSK.
  - (b) Scroll to ICE PROT using the inner knob and press the inner knob to select.
  - (c) Scroll to the ECB — R PITOT HEAT (R FWD Bus) using the outer knob and press the RESET LSK.

(4) **If you are using two Extech EX470 or equivalent to measure the temperature:**

NOTE: Probe tip heat should be on for at least 5 minutes before power is removed, unless temperature exceeds 550°C.

(a) Start timer and monitor the SCASS-020G-12-SHX and the SCASS-062G-6-SHX.

1. Record peak temperature for the upper AOA (SCASS-020G-12-SHX). This should take no longer than two minutes and be a minimum of 100°C.
2. Record peak temperature of the probe tip (SCASS-062G-6-SHX). This should take no longer than 5 minutes. If the probe heat should exceed 550°C within 5 minutes, PULL ECB – R PITOT HEAT (R FWD Bus).
3. The probe tip temperature must reach a minimum of 370°C and not exceed 550°C within the 5 minutes.

(5) **If you are using one Extech EX470 or equivalent, measure the ambient temperature in conjunction with a SCASS-020G-12-SHX thermocouple:**

(a) Start the timer and monitor the upper AOA port using the Extech EX470 and SCASS-020G-12-SHX thermocouple.

1. Record peak temperature. This should take no longer than two minutes and be a minimum of 100°C.

NOTE: Probe tip heat should be on for at least 5 minutes before power is removed, unless temperature exceeds 550°C.

(b) Once the upper AOA port peak temperature has been reached and recorded, unplug the SCASS-020G-12-SHX and immediately plug in SCASS-062G-6-SHX thermocouple.

1. Record peak temperature of the probe tip (SCASS-062G-6-SHX). This should take no longer than 5 minutes. If the probe heat should exceed 550°C within 5 minutes, PULL ECB – R PITOT HEAT (R FWD Bus).
2. The probe tip temperature must reach a minimum of 370°C and not exceed 550°C within the 5 minutes.

(6) Using left/right lower knob on MFD, scroll to the ECB synoptic page. Press ECB BY SYSTEM LSK and using inner knob scroll to ICE PROT. Press inner knob to select. Using outer knob, scroll to ECB - R PITOT HEAT (R FWD Bus) and press the PULL LSK.

(a) Verify the “R PITOT HEAT FAIL” CAS message illuminates.

**F. Pitot/Static Probe Test:**

(Refer to [Fig. 501](#) when recording test results.)

- (1) Insert the SCASS-062G-6-SHX thermocouple 0.8 +/-0.1 inch into the ram air port of the Standby Pitot/Static probe.
- (2) On the MFD:
  - (a) Scroll to the ECB synoptic page using the left/right lower knob and press ECB BY SYSTEM LSK.
  - (b) Scroll to ICE PROT using the inner knob and press the inner knob to select.
  - (c) Scroll to the ECB — STBY PITOT HEAT (BATT Bus) using the outer knob and press the RESET LSK.
- (3) Start timer and monitor the probe tip temperature.

NOTE: Probe tip heat should be on for at least 5 minutes before power is removed, unless temperature exceed 400°C

  - (a) Record peak temperature of the probe tip (SCASS-062G-6-SHX). This should take no longer than 5 minutes. If the probe heat should exceeds 400°C within 5 minutes, PULL ECB – STBY PITOT HEAT (BATT Bus).
  - (b) The probe tip temperature must reach a minimum of 230°C and not exceed 400°C within the 5 minutes.
- (4) Using left/right lower knob on MFD, scroll to the ECB synoptic page. Press ECB BY SYSTEM LSK and using inner knob scroll to ICE PROT. Press inner knob to select. Using outer knob scroll to ECB - STBY PITOT HEAT (BATT Bus) and press the PULL LSK.
  - Verify the “STBY PITOT HEAT FAIL” CAS message illuminates.
- (5) On MFD scroll to ICE synoptic page by using the lower left/right knob, press the PITOT/STATIC LSK to select AUTO.

**G. Pitot/AOA Probe Auxiliary Heater:**

**NOTE:** Three to four persons are necessary for this procedure, one person to monitor the cockpit displays, one person to apply freeze spray to the OAT probe, and one or two persons to measure the Auxiliary Heater temperatures.

**CAUTION:** A WOW SIMULATOR BOX WILL BE INSTALLED WHICH OVERRIDES THE INTERLOCK TO THE LANDING GEAR HANDLE. THE HANDLE MUST BE DOWN FOR THIS ENTIRE TEST OR DAMAGE TO THE AIRCRAFT AND INJURY TO PERSONNEL CAN OCCUR.

**CAUTION:** WHEN USING THE WOW BOX, AMC (WOW FUNCTION) OR JACKING WITH ELECTRICAL POWER APPLIED, SET TRANSPONDER TO STBY ON THE PFD AFTER SELECTING W-OFF-W OR WHEN AIRCRAFT IS IN WEIGHT OFF WHEELS CONDITION. IF TRANSPONDER IS NOT SET TO STBY THE AIRCRAFT WILL CAUSE NUISANCE TRANSPONDER TRANSMISSIONS TO THE LOCAL AIRFIELD AND OTHER AIRCRAFT.

- (1) To simulate Weight-off-Wheels, connect either AMC or WOW Box to aircraft. Refer to [AMM-20-00-04-051-801 – Weight On Wheels \(WOW\) Box - Connect/Disconnect](#) Set the WOW Box or AMC to W Off W.
- (2) Using tab select knob on the lower right side of the MFD, scroll to the SETUP tab, select the SENSORS LSK. Use the outer dual concentric knob to scroll vertically and the inner dual concentric knob to scroll horizontally, select ADC 1 for ADC PFD SOURCE SELECTION.
- (3) Using left/right lower knob on MFD, scroll to the ECB synoptic page. Press the ECB BY SYSTEM LSK and using outer knob scroll to ICE PROT, press the inner knob to select.
- (4) Scroll to the ICE synoptic page on the MFD by using the lower left/right LSK.
- (5) Using left/right lower knob on MFD, scroll to the ECB synoptic page. Press ECB BY SYSTEM LSK and using inner knob scroll to ICE PROT. Press inner knob to select. Using outer knob scroll to ECB - AUX PROBE HEAT (L AFT Bus) and press the PULL LSK.
  - Verify the “AUX PROBE HEAT” Advisory CAS message illuminates.
- (6) Scroll to the ECB - AUX PROBE HEAT (L AFT Bus) using the outer knob and press the RESET LSK.
  - “AUX PROBE HEAT” Advisory CAS message disappears.
- (7) Apply Freeze Spray to LH OAT Probe.
- (8) Monitor OAT temperature on the ICE synoptic page and the ICE PROT ECB page.
  - (a) AUX PROBE HEAT ECB turns on at  $-30^{\circ}$  C and below.
  - (b) AUX PROBE HEAT ECB turns off at  $-30^{\circ}$  C and above.

- 
- (9) Measure auxiliary temperatures, apply thermocouple on the aircraft skin next to the Pitot/AOA probe skin cut out, 0.25 inch from edge of skin cut out.
- NOTE: Both auxiliary heaters turn on at the same time.
- NOTE: Do not turn power on to the probes during the auxiliary heater test.
- (a) Within one minute, temperature should be +12° C above ambient temperature.
- (b) Repeat temperature measurement for the opposite side auxiliary heater.
- NOTE: Disregard this step if both Pitot/AOA temperature measurements were taken concurrently.
- (10) Using tab select knob on the lower right side of the MFD, scroll to the SETUP tab, select the SENSORS LSK. Use the outer dual concentric knob to scroll vertically and the inner dual concentric knob to scroll horizontally, select ADC 2 for ADC PFD SOURCE SELECTION.
- (11) Apply Freeze Spray to RH OAT Probe.
- (12) Monitor OAT temperature on the ICE synoptic page and the ICE PROT ECB page.
- (a) AUX PROBE HEAT ECB turns on at -30° C and below.
- (b) AUX PROBE HEAT ECB turns off at -30° C and above.
- (13) Measure auxiliary temperatures, apply thermocouple on the aircraft skin next to the Pitot/AOA probe skin cut out, 0.25 inch from edge of skin cut out.
- NOTE: Both auxiliary heaters turn on at the same time.
- NOTE: Do not turn power on to the probes during the auxiliary heater test.
- (a) Within one minute, temperature should be +12° C above ambient temperature.
- (b) Repeat temperature measurement for the opposite side auxiliary heater.
- NOTE: Disregard this step if both Pitot/AOA temperature measurements were taken concurrently.
- (14) Set the WOW Box or AMC to W On W.

---

**H. Test Completion:**

- (1) Using left/right lower knob on MFD, scroll to the ECB synoptic page. Press ECB BY SYSTEM LSK and using outer knob scroll to ICE PROT. Press inner knob to select. Using outer knob, scroll to select ECB and press the RESET LSK for the following ECBs:
  - ECB - DEICE MANIFOLD HTR (R AFT Bus)
  - ECB - L PITOT HEAT (L FWD Bus)
  - ECB - R PITOT HEAT (R FWD Bus)
  - ECB - L STATIC HEAT (BATT Bus)
  - ECB - L STATIC HEAT (R FWD Bus)
  - ECB - R STATIC HEAT (L FWD Bus)
  - ECB - R STATIC HEAT (R FWD Bus)
  - ECB - STBY PITOT HEAT (BATT Bus)
  - ECB - L WINDSHIELD HEAT (L AFT Bus)
  - ECB - R WINDSHIELD HEAT (R AFT Bus)
- (2) Power down the aircraft by setting the SYS BATT and START BATT switches to OFF and the BUS TIE to OPEN.
- (3) If used, disconnect the AMC or WOW Box from the aircraft. Refer to AMM-20-00-04-051-801 – Weight On Wheels (WOW) Box - Connect/Disconnect.

**4. Job Close Up**

SUBTASK AMM-30-30-00-071-B-921-002

- A. Remove all tools, equipment, and unwanted material, from work area.
- B. If all other maintenance is complete, return aircraft to service. Refer to [AMM-20-00-02-051-801 – Return To Service \(After Maintenance\)](#).

Aircraft Registration Number / Serial Number		/
Date of Probe Test		
Ambient Temperature °C		
LH Pitot Probe	Probe Part Number	
	Probe Software Version	
	Date of Manufacture	
	SCASS-062G-6SHX Peak Temperature °C – <i>Time Required to Reach Peak Temperature</i>	
	SCASS-020G-12-SHX Peak Temperature °C	
	Auxiliary Heater Peak Temperature °C	
RH Pitot Probe	Probe Part Number	
	Probe Software Version	
	Date of Manufacture	
	SCASS-062G-6SHX Peak Temperature °C – <i>Time Required to Reach Peak Temperature</i>	
	SCASS-020G-12-SHX Peak Temperature °C	
	Auxiliary Heater Peak Temperature °C	
STDY Pitot Probe	Probe Part Number	
	Probe Software Version	
	Date of Manufacture	
	SCASS-062G-6SHX Peak Temperature °C – <i>Time Required to Reach Peak Temperature</i>	

**Probe Test Table  
Figure 501 (Sheet 1 of 1)**

---

**PITOT AND STATIC ANTI-ICE SYSTEM - DESCRIPTION AND OPERATION**

AMM-30-30-00-081-A-801

**1. General**

- A. The pitot and static anti-ice system prevents ice buildup on the pitot tubes and static ports.
- B. The pitot and static anti-ice system is made up of the components that follow:
  - Aircraft Computer System (ACS)
  - Two Pitot/Angle of Attack (AOA) probes
  - One Pitot/Static Standby probe
  - Two dual Static ports

**2. Description**

SUBTASK AMM-30-30-00-081-A-871-001

- A. The Pitot/AOA probes are located on the left and right sides of the forward fuselage. Each probe faces forward into the relative wind during flight and is heated by an internal electrical heater element to provide anti-ice protection. Refer to [Fig. 1, Sheet 1](#).
- B. The standby pitot/static probe is located on the left side of the forward fuselage, above the left pitot/AOA probe. The standby pitot/static probe faces forward into the relative wind during flight and is heated by an internal electrical heater element to provide anti-ice protection.
- C. The two static ports are located on the upper left and upper right side of the forward fuselage. Each port faces out from the aircraft, at right angles to the relative wind, so that static air pressure will not be affected by aircraft speed. Each dual static port is heated by an internal electrical heater element to provide anti-ice protection.

**3. Operation**

SUBTASK AMM-30-30-00-081-A-871-002

- A. All pitot/AOA probes and static ports are automatically heated when either engine is running or when there is no Weight on Wheels. Also, when the engines are not running, a PITOT STAT line select key on the ICE page allows the crew to select probe heat ON. When probe heat is ON, the ACS supplies electrical power the heater in each probe. The heaters prevent the accumulation of ice on the probes.

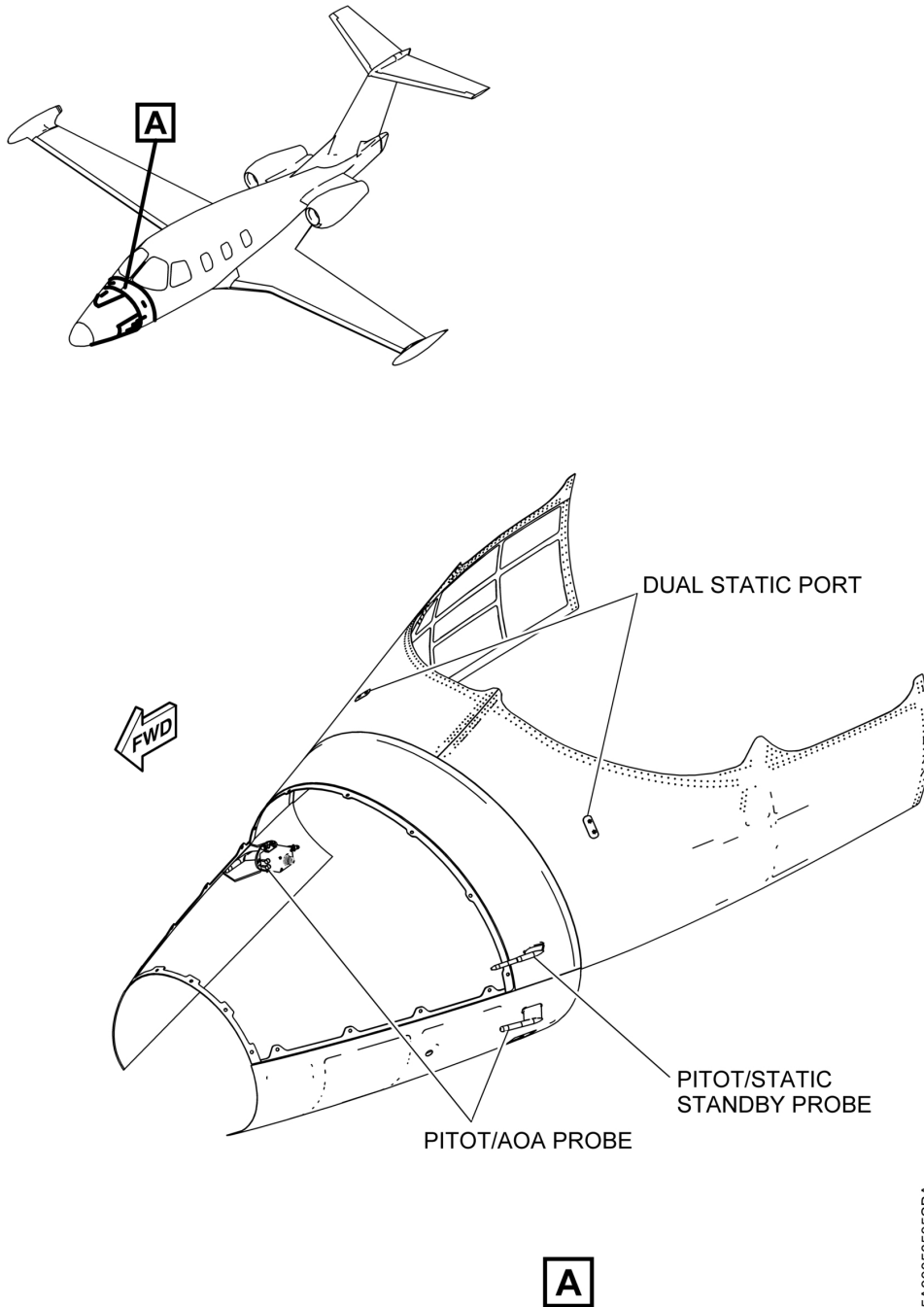

**Pitot and Static Anti-Ice System - Description and Operation**  
**Figure 1 (Sheet 1 of 1)**

5A30050505SBA

---

## **PITOT AND STATIC ANTI-ICE SYSTEM - DESCRIPTION AND OPERATION**

AMM-30-30-00-081-B-801

### **1. General**

- A. The pitot and static anti-ice system prevents ice buildup on the pitot tubes and static ports.
- B. The pitot and static anti-ice system is made up of the components that follow:
  - Aircraft Computer System (ACS)
  - Two pitot/Angle of Attack (AOA) probes
  - One pitot/static standby probe
  - Two dual static ports
  - Two pitot/Angle of Attack (AOA) probe auxiliary heaters

### **2. Description**

SUBTASK AMM-30-30-00-081-B-871-001

- A. The pitot/AOA probes are located on the left and right sides of the forward fuselage. Each probe faces forward into the relative wind during flight and is heated by an internal electrical heater element to provide anti-ice protection. Refer to [Fig. 1, Sheet 1](#).
- B. The standby pitot/static probe is located on the left side of the forward fuselage, above the left pitot/AOA probe. The standby pitot/static probe faces forward into the relative wind during flight and is heated by an internal electrical heater element to provide anti-ice protection.
- C. The two static ports are located on the upper left and upper right side of the forward fuselage. Each port faces out from the aircraft, at right angles to the relative wind, so that static air pressure will not be affected by aircraft speed. Each dual static port is heated by an internal electrical heater element to provide anti-ice protection.
- D. The pitot/Angle of Attack (AOA) probe auxiliary heaters are installed on the left and right pitot/AOA probes.

### **3. Operation**

SUBTASK AMM-30-30-00-081-B-871-002

- A. All pitot/AOA probes and static ports are automatically heated when either engine is running or when there is no Weight on Wheels. Also, when the engines are not running, a PITOT STAT line select key on the ICE page allows the crew to select probe heat ON. When probe heat is ON, the ACS supplies electrical power the heater in each probe. The heaters prevent the accumulation of ice on the probes.

- | B. Pitot/AOA probe auxiliary heaters are automatically activated when the OAT at  $-30^{\circ}\text{C}$  or below.

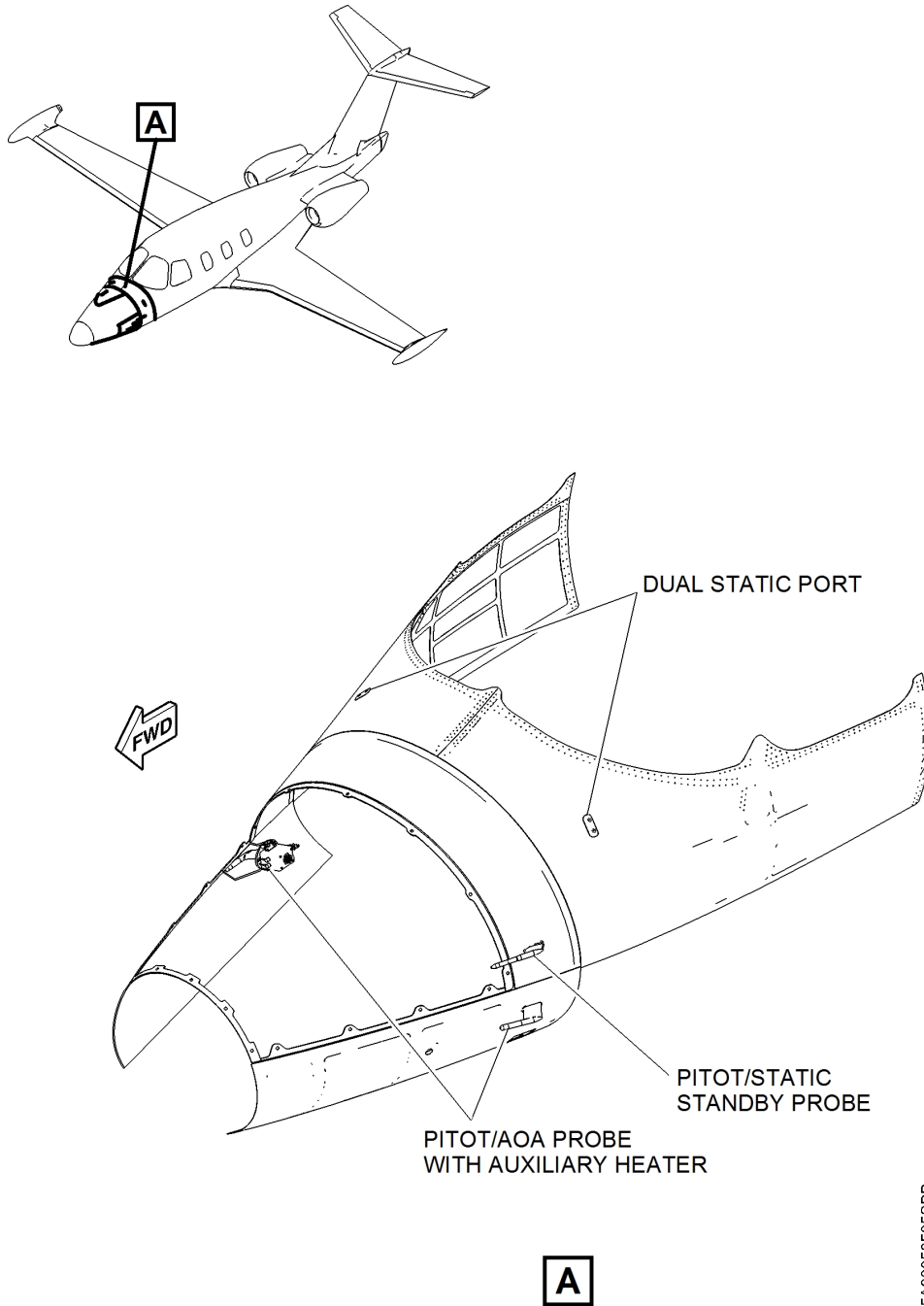

**Pitot and Static Anti-Ice System - Description and Operation**  
**Figure 1 (Sheet 1 of 1)**

5A30050505SBB

THIS PAGE INTENTIONALLY LEFT BLANK

---

**PITOT/AOA PROBE AUXILIARY HEATER - REMOVAL**

AMM-30-30-10-001-801

**1. General**

- A. This task gives the procedures to remove the Auxiliary Heater from the Pitot/Angle of Attack (AOA) probes.

**2. Job Set-Up**

SUBTASK AMM-30-30-10-001-921-001

- A. This task assumes access to the Pitot/AOA probe has been removed. For Pitot/AOA probe removal instructions refer to [AMM-34-10-10-001-C-801 – Pitot/AOA Probes - Removal](#)

**3. Procedure**

SUBTASK AMM-30-30-10-001-011-001

(Refer to [Fig. 401, Sheet 1.](#))

- A. Remove the auxiliary heater [\(2\)](#) from Pitot/AOA probe [\(1\)](#) .

NOTE: Once removed from the pitot/AOA probe, the auxiliary heaters can not be reused.

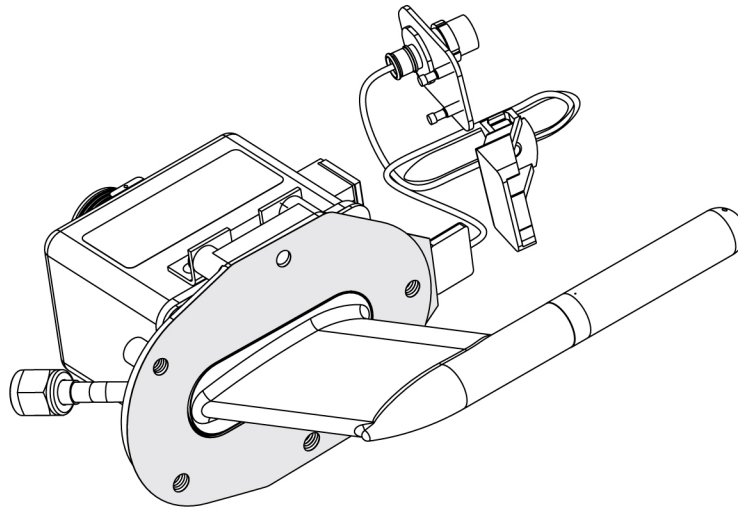

LH Pitot/AOA Probe

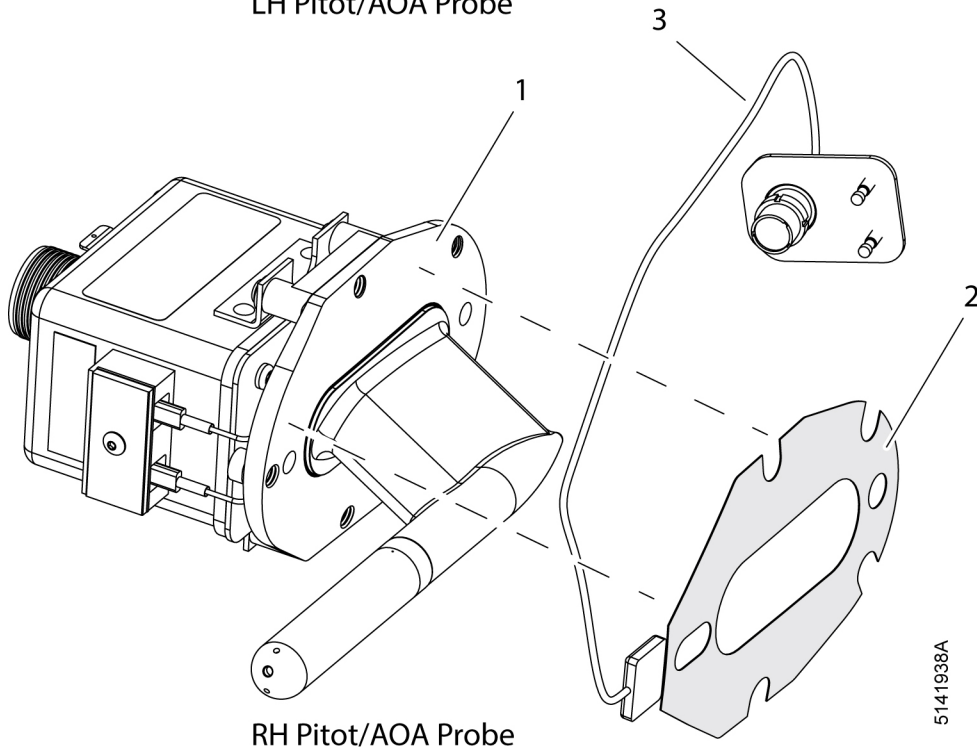

RH Pitot/AOA Probe

5141938A

**Pitot/AOA Probe Auxiliary Heater - Removal/Installation**  
**Figure 401 (Sheet 1 of 1)**

---

**PITOT/AOA PROBE AUXILIARY HEATER - INSTALLATION**

AMM-30-30-10-041-801

**1. General**

- A. This task gives the procedures to install the Auxiliary Heater on the Pitot/Angle of Attack (AOA) probes.

**2. Job Set-Up**

SUBTASK AMM-30-30-10-041-921-001

- A. Make sure aircraft is in the same configuration as it was when the removal task was completed. Refer to [AMM-30-30-10-001-801 – Pitot/AOA Probe Auxiliary Heater - Removal](#).

**3. Procedure**

SUBTASK AMM-30-30-10-041-411-001

(Refer to [Fig. 401, Sheet 1.](#))

- A. Clean probe flange (1) on skin-side surface only. Refer to [AMM-20-08-00-051-801 – Sealants and Adhesives - Maintenance Practices](#).

NOTE: Make sure surface is clean, dry, and free of contamination.

- B. Remove protective adhesive liner from heater (2).

- C. Apply heater (2) to prepared flange of probe (1).

NOTE: When locating heater on face of flange, ensure the heater edge does not contact or foul on mounting hardware.

- D. Make sure no air bubbles or wrinkles are present on the heater after installation.

**4. Job Close-Up**

SUBTASK AMM-30-30-10-041-921-002

- A. This task does not install the Pitot/AOA probe. For Pitot/AOA probe installation instructions refer to [AMM-34-10-10-041-C-801 – Pitot/AOA Probes - Installation](#).

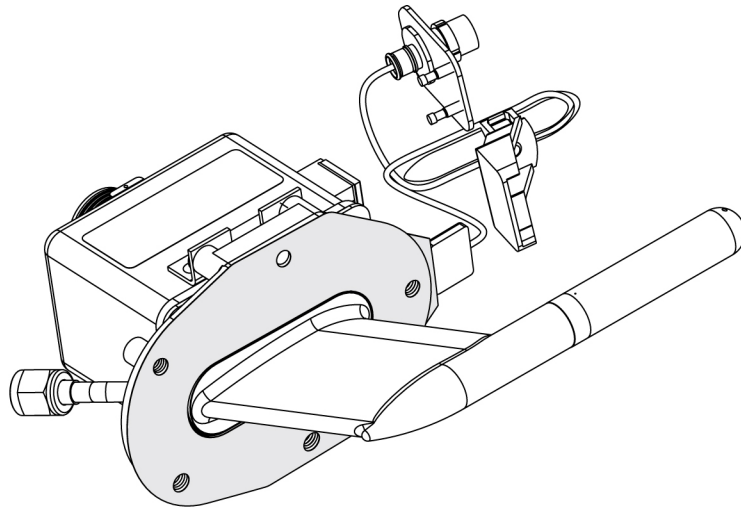

LH Pitot/AOA Probe

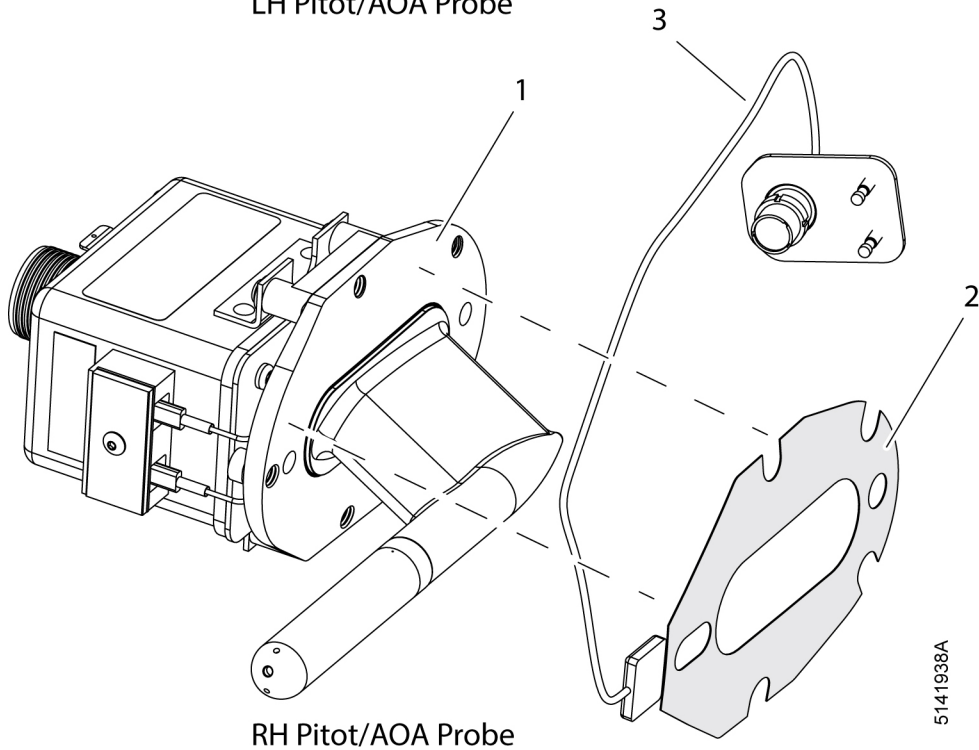

RH Pitot/AOA Probe

5141938A

**Pitot/AOA Probe Auxiliary Heater - Removal/Installation**  
**Figure 401 (Sheet 1 of 1)**