

---

**CHAPTER - 32 HIGHLIGHTS**  
**(Summary of Changes)***Revision No. TR32-6 Aug 18/20*

TO: HOLDERS OF THE AIRCRAFT MAINTENANCE MANUAL (06-123838)

Pages that have been added or revised are summarized below. Remove and insert the affected pages as listed, and enter the above revision number with issue date into the Record of Revisions sheet.

**This Temporary Revision incorporates and supersedes previously released temporary revisions for the chapters listed below.**

*Do not remove this page. Keep it in place as a record of previous changes.*

<b>CH/SE/SU Page Block No.</b>	<b>Description of Change</b>
32-10-13 PgBlk 801	Added MLG Shock Absorber seal repack procedure.
32-40-00 PgBlk 501	Updated Required Equipment, Tools, and Instruments. Added DECU p/n D303121 testing procedures.

THIS PAGE INTENTIONALLY LEFT BLANK

---

**MAIN LANDING GEAR SHOCK ABSORBER ASSEMBLY - REPACK**

AMM-32-10-13-031-801

**1. General**

- A. This task gives the procedures to repack the Main Landing Gear (MLG) shock absorber assembly seals.

There are six seals to be replaced.

(Refer to [Fig. 801.](#))

- Back-up ring [\(5\)](#)
- O-ring [\(6\)](#)
- AGT ring [\(9\)](#)
- AGT ring [\(11\)](#)
- Back-up ring [\(13\)](#)
- O-ring [\(14\)](#)

**NOTE:** This procedure is for the repacking of the Main Landing Gear Shock Absorber seals and is not to be used as for shock absorber overhaul.

**2. Job Set-Up**

SUBTASK AMM-32-10-13-031-921-001

- A. Required Test Equipment

- M041-07T005-101/103: Extraction Tool Striker
- M041-07T009-041: Valve Assembly Extraction Tool
- Moog L853-001: Test Rig or equivalent
- Hydraulic hand pump: Commercially available
- 3 way hydraulic fluid distributor: Commercially available

**3. Procedure**

SUBTASK AMM-32-10-13-031-411-001

(Refer to [Fig. 801.](#))

- A. Remove Shock Absorber from Main Landing Gear. Refer to [AMM-32-10-13-001-801 – Main Landing Gear Shock Absorber Assembly - Removal](#) .

- B. DISASSEMBLY

**NOTE:** Inspect parts during disassembly for damage. If damaged parts are found other than the seals identified for replacement, replace the shock absorber.

**WARNING: MAKE SURE SAFETY PRECAUTIONS ARE OBEYED WHEN WORKING ON NITROGEN SYSTEM OR COMPONENTS. INJURY TO PERSONNEL AND OR DAMAGE TO EQUIPMENT CAN OCCUR. USE PROTECTIVE GOGGLES AND GLOVES.**

**CAUTION: SHOCK ABSORBER MUST BE UPRIGHT WHEN NITROGEN PRESSURE IS RELEASED, OR ELSE DAMAGE TO EQUIPMENT CAN OCCUR.**

- (1) Open the charging valve (15) and let nitrogen and hydraulic fluid mix go out through the valve into a suitable container.
- (2) When the unit is completely depressurized loosen and remove the charging valve (16).
- (3) Drain any remaining hydraulic fluid from the shock absorber.
- (4) Loosen and remove three screws (22) and remove the target WOW (21).
- (5) Remove ring retainer (19).
- (6) Remove four pin dowels (23) using tool M041-07T005-101/103.
- (7) Separate the piston assy (2) and the other installed items from the cylinder assembly (24).
- (8) Remove the slydring (18).
- (9) Remove four pin dowels (3) from piston (2) and remove the piston head (17).
- (10) Remove stop ring (8) and flat valve (7).
- (11) Extract the valve assy (4) using tool M041-07T009-041.
- (12) Remove the back up ring (5) and the O-ring (6) from valve (4).
- (13) Remove the back up ring (13) and the O-ring (14).
- (14) Remove the gland (12) from piston (2).
- (15) Remove the hard landing indicator (20).
- (16) Remove the excluder (9), the slydring (10), and the AGT ring (9) from gland (12).

---

**SUBTASK AMM-32-10-13-031-411-002**

(Refer to [Fig. 801.](#))

**A. PRE-ASSEMBLY**

- (1) The following seals are to be replaced:
  - Back-up ring [\(5\)](#)
  - O-ring [\(6\)](#)
  - AGT ring [\(9\)](#)
  - AGT ring [\(11\)](#)
  - Back-up ring [\(13\)](#)
  - O-ring [\(14\)](#)
- (2) Install the elastic ring [\(1\)](#) on its seat on the top of the piston [\(2\)](#) .
- (3) Slide the hard landing indicator [\(20\)](#) and the retainer ring [\(19\)](#) on the piston.
- (4) Install the AGT ring [\(11\)](#) , the slydring [\(10\)](#) and the excluder DC [\(9\)](#) into the gland [\(12\)](#) .
- (5) Install the O-ring [\(14\)](#) and the back-up ring [\(13\)](#) on the gland [\(12\)](#) .
- (6) Slide the gland [\(12\)](#) on piston [\(2\)](#) .
- (7) Install the O-ring [\(6\)](#) and the back-up ring [\(5\)](#) on the valve [\(4\)](#) .
- (8) Install the flat valve [\(7\)](#) and the stop ring [\(8\)](#) on the bottom of the valve [\(4\)](#) .
- (9) Install the valve group and the piston head [\(17\)](#) on the bottom of the piston [\(2\)](#) . Make sure that all the components holes are aligned.
- (10) Lock all the group to the piston with four pins [\(3\)](#) .
- (11) Install piston bearing [\(18\)](#) .
- (12) Put the piston group into the cylinder [\(24\)](#) and make sure to have the four cylinder holes coincident with the gland holes.
- (13) Install four pins [\(23\)](#) .
- (14) Push the hard landing indicator [\(20\)](#) against the gland [\(12\)](#) .
- (15) Move the ring retainer [\(19\)](#) to have its four holes coincident with the installed pin holes.
- (16) Install the WOW target [\(21\)](#) and lock it with three screws [\(22\)](#) , torque the screws to 12-15 lbf.in (1.36-1.69 Nm).
- (17) Apply PRC-Desoto polysulfide sealant (P/S 890 Class A or C) to the mating surfaces of the three screws [\(22\)](#) , WOW target [\(21\)](#) , ring retainer [\(19\)](#) , hard landing indicator [\(20\)](#) , and top of the piston [\(2\)](#) . Refer to [Fig. 803](#) and [AMM-20-08-00-051-801 – Sealants and Adhesives - Maintenance Practices.](#)
- (18) Temporary install the charging valve [\(16\)](#) with its O-ring [\(15\)](#) .

**SUBTASK AMM-32-10-13-031-411-003**

(Refer to [Fig. 801](#) and [Fig. 803](#).)

A. HYDRAULIC FLUID FILLING - PROOF PRESSURE CHECK OF THE SHOCK ABSORBER

**WARNING: BEFORE TO PROCEED, MAKE SURE THAT THERE IS NO PRESSURE IN THE UNIT. DO NOT PRESSURIZE SHOCK ABSORBER TO MORE THAN THE SPECIFIED PRESSURE. IT IS DANGEROUS AND COULD KILL OR CAUSE INJURY.**

- (1) Install the shock absorber in the test rig in the vertical position, with the charging valve on the top.
- (2) Remove the charging valve [\(16\)](#).
- (3) Remove the elastic ring [\(1\)](#).
- (4) Connect the hose which supplies fluid to the valve port with a two way fitting.
- (5) Set the test rig to permit the free extension of the shock absorber.
- (6) Set the 3 way distributor to pressure.
- (7) Fill with hydraulic fluid until the shock absorber is fully extended. Do not let the hydraulic fluid pressure exceed 363 psi (25 bar).
- (8) Set the 3 way distributor to return.
- (9) Slowly compress until the shock absorber is in the fully compressed position, and let the excess hydraulic fluid go out.
- (10) Repeat steps 6 to 9 until the hydraulic fluid becomes free of bubbles.
- (11) Check that the total stroke from the fully extended to the fully compressed position of the shock absorber is  $4.9611 \pm 0.4$  in ( $126 \pm 1$  mm).
- (12) Keep the shock absorber restrained and fill with hydraulic fluid until the shock absorber is approximately half stroke.
- (13) Apply proof pressure of 4540 psi (313 bar) and keep it for 180 seconds. Check for external leakage.

**CAUTION: DO NOT APPLY THE PROOF PRESSURE WITH THE MLG FULLY EXTENDED AGAINST THE PISTON-TO-GLANDS ABUTMENTS.**

- (14) Fill with hydraulic fluid until the shock absorber is in the fully extended position.
- (15) Set the 3 way distributor to return and slowly compress the shock absorber until it is in the fully compressed position.
- (16) Drain the excess hydraulic fluid.
- (17) Remove the two way fitting and install the charging valve [\(16\)](#) with a new O-ring [\(15\)](#).
  - (a) Apply lubricant (Dow Corning 55 O-Ring Lubricant) on the new O-ring [\(15\)](#).
- (18) Install the elastic ring [\(1\)](#).
- (19) Lockwire the following items with MS20995C32 lockwire.

- 
- (a) Three screws (22) .
  - (b) Charging valve (16) .
  - (20) Apply PRC-Desoto polysulfide sealant (P/S 890 Class A or C) around the charging valve body (16) and shock absorber (2) . Refer to Fig. 803 and [AMM-20-08-00-051-801 – Sealants and Adhesives - Maintenance Practices](#).
  - (21) Install and tighten the charging valve cap by hand.
  - B. Install Shock Absorber on to Main Landing Gear. Refer to [AMM-32-10-13-041-801 – Main Landing Gear Shock Absorber Assembly - Installation](#) .
  - C. Do servicing of Main Landing Gear. Refer to [AMM-12-10-06-061-801 – Landing Gear - Servicing](#) .
  - D. After one hour, inspect main landing gear shock absorber for hydraulic fluid leaks. Make sure that Dimension H falls with in the tolerances shown in [AMM-12-10-06-061-801 – Landing Gear - Servicing](#) SUBTASK AMM-12-10-06-061-611-002.

#### 4. **Job Close-Up**

SUBTASK AMM-32-10-13-041-921-008

- A. Remove all tools, equipment and unwanted material from work area.

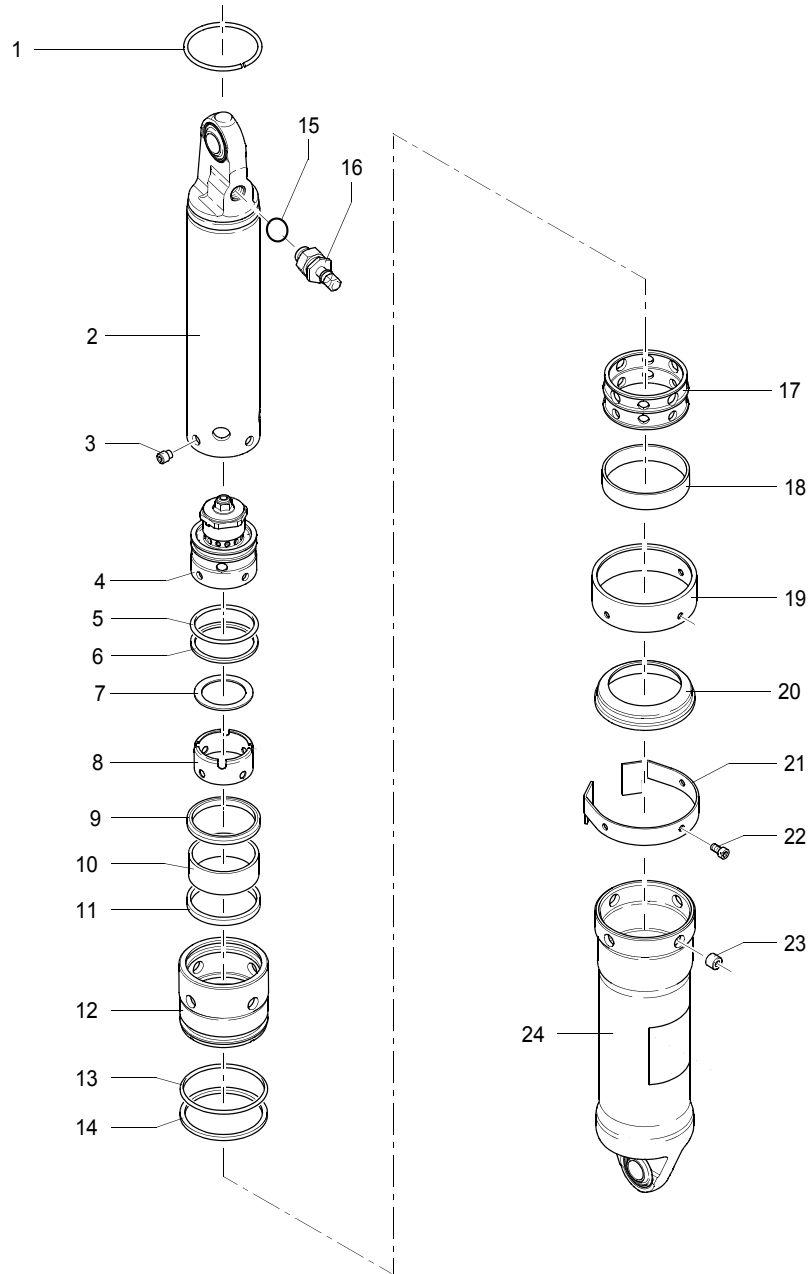

**Main Landing Gear Shock Absorber Assembly - Repack**  
**Figure 801 (Sheet 1 of 1)**

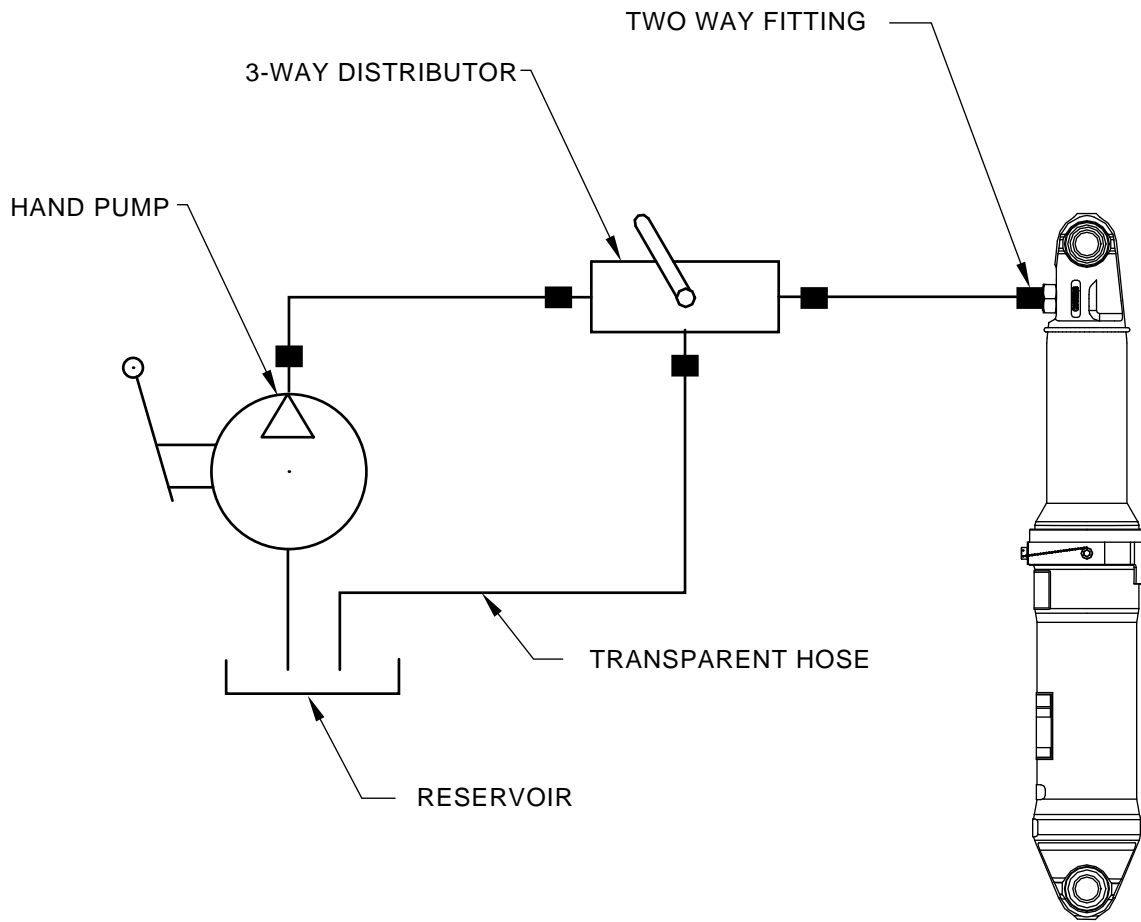

**Hydraulic Fluid Filling Schematic**  
**Figure 802 (Sheet 1 of 1)**

5181973A

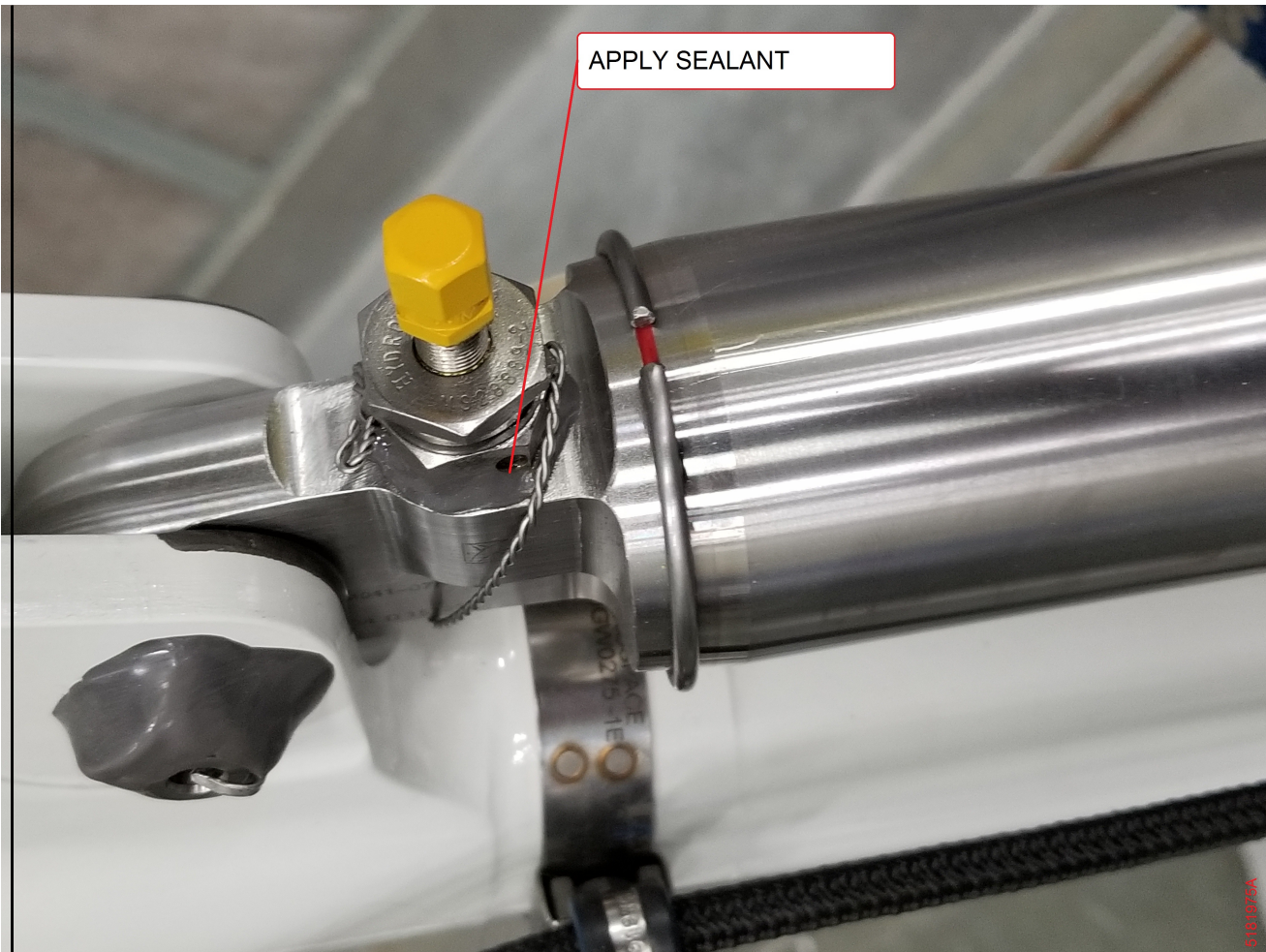

**Sealant Application  
Figure 803 (Sheet 1 of 2)**



**Sealant Application**  
**Figure 803 (Sheet 2 of 2)**

THIS PAGE INTENTIONALLY LEFT BLANK

---

**ANTI-SKID BRAKE SYSTEM - ADJUSTMENT/TEST**

AMM-32-40-00-071-801

**1. General****A. Purpose and Scope**

The purpose of this Functional Test Procedure (FTP) is to verify that the anti-skid braking system is installed correctly and will function properly and otherwise meet the requirements of the installation drawings.

**WARNING: ASSURE THAT ALL COCKPIT CONTROLS ARE SET TO POSITIONS THAT WILL NOT RESULT IN INADVERTENT ACTUATIONS OF SYSTEMS WHEN ELECTRICAL POWER IS APPLIED TO THE AIRCRAFT.**

**B. Airplane Configuration**

The aircraft must be in a configuration to allow electrical power, with all equipment and component installations complete prior to performing this FTP.

**WARNING: PRIOR TO PERFORMING ANY TESTS OR MAINTENANCE ON THE HYDRAULIC SYSTEMS, PERSONNEL SHOULD READ AND THOROUGHLY UNDERSTAND THE FOLLOWING PRECAUTIONS.**

**C. Safety Requirements**

Appropriate safety precautions must be taken in the following areas:

**(1) Personnel Safety Precautions**

- (a) Wash hands thoroughly with soap and water before working on open hydraulic systems.
- (b) Wear appropriate eye protection anytime there is a possibility of hydraulic fluid splash or when pressure testing components or systems.
- (c) If fluid splashes in the eyes, treat eyes immediately by rinsing thoroughly with clean cool water.
- (d) Ensure and verify that system pressure is completely depleted before attempting to loosen a hydraulic line fitting.

**(2) Hydraulic System Contamination**

- (a) Use only clean Mil-PRF-87257 hydraulic fluid for brake system.
- (b) When a hydraulic line or fitting is opened, the potential for contamination of the hydraulic system is high.
  - Caps and or plugs must be inserted immediately to prevent contaminants from entering the system.
  - All hands and tools must be free of dirt and grease.

#### D. Test Summary

The tests in this task are summarized in [Table 501](#) below.

**Table 501. Component Test Matrix**

Test	Subtask
System Bleeding [1]	SUBTASK AMM-32-40-00-071-801-001
Brake Line Proof Pressure Test [2]	SUBTASK AMM-32-40-00-071-801-002
Update DECU Configuration Settings	DECU p/n D301102 SUBTASK AMM-32-40-00-071-801-003-A or DECU p/n D303121 SUBTASK AMM-32-40-00-071-801-003-B
Operational Checks <ul style="list-style-type: none"> <li>• <i>System Functional Checks</i></li> <li>• <i>Control Functional Checks</i></li> <li>• <i>Invalid ARINC 429 Functional Check</i></li> <li>• <i>Disconnected WST Functional Check</i></li> </ul>	SUBTASK AMM-32-40-00-071-801-004
Troubleshooting	SUBTASK AMM-32-40-00-071-801-005

- [1] For proper operation of the Anti-skid Brake System (ABS), the following procedure must be used to effectively remove all entrapped air from the braking system. If any component of the brake system below the master cylinder has been replaced, it will be required to bleed the system using the following procedure.
- [2] Perform the Brake Line Proof Pressure Test, if installing new ABS components starting from the Master Cylinder and ending before the Brake Control Module (BCM).

#### E. Testing Sequence

Testing shall be performed in the order shown. If for any reason a testing section is not completed (e.g., a malfunction or discrepancy) then that section must be repeated in its entirety. Once begun, completion of a test section is important for continuity and accurate test results. All aircraft systems should be returned to normal configuration when a section is halted for any reason.

## F. Required Equipment, Tools, and Instruments

Equipment Name	Equipment Details
Ground Power Unit (GPU) <u>NOTE:</u> 0-28 VDC Electrical Ground Power Unit.	AllStar 450 or AllStar G.S.E. or Hobart GPU-400 or Hobart GPU-600 or Bycan PS-28100
D-Pak Bleed Cart <u>NOTE:</u> Brake bleeding unit.	Parker - Fluidpower System D50.9U10P0/20 or Equivalent.
Hydraulic Hand Pump	Capable of at least 3000 psi.
Pressure Gauge 0 - 4000 psi <u>NOTE:</u> To attach to hydraulic line at RH Brake assembly.	Hydraulic pressure gauge with a minimum resolution of 50 psi and range 0 - 4000 psi.
BCM TDR Test Harness <u>NOTE:</u> To verify Time Delay Relays	20-124719-* [1]
20-124558-* [1]	ABS Functional Test Box
Stop Watch	1 second resolution
Torque wrench	10 - 100 in-lbs. torque range
Safety glasses	
Caps and plugs	As needed to prevent contamination of hydraulic lines.
DECU Configuration Harness (20-124718-1001)	DECU Configuration
USB to RS-232 Converter (205146)	DECU Configuration
Avio Maintenance Computer (AMC) (EAI 20-120576-1001 or 20-121926-1001), SW version "2.5.10 or higher"	DECU Configuration DECU p/n D301102 Configuration
Personal Computer or Laptop	Windows OS: XP Service Pack 2. DECU p/n D303121 Configuration

[1] Highest effective dash number and/or revision.

---

## 2. **System Bleeding**

SUBTASK AMM-32-40-00-071-801-001

### A. General

For proper operation of the Anti-skid Brake System, the following procedure must be used to effectively remove all entrapped air from the braking system. If any component of the brake system below the master cylinder has been replaced, it will be required to bleed the system using the following procedure.

### B. Brake Bleeding

Bleed the brake system per the instructions in the Eclipse Model EA500 Maintenance Manual section [AMM-32-40-00-061-801 – Wheels and Brakes - Servicing](#).

## 3. **Brake Line Proof Pressure Test**

SUBTASK AMM-32-40-00-071-801-002

### A. General

Perform the Brake Line Proof Pressure Test if installing new Anti-skid Brake System (ABS) components starting from the Master Cylinder and ending before the Brake Control Module (BCM).

### B. Brake Line Proof Pressure Test

- (1) With dry rags, clean any residual hydraulic fluid and liquids from brake lines, fittings, and components, as well as adjacent areas where hydraulic fluid might leak, in the left and right wheel wells.
- (2) The test set-up is shown schematically in [Fig. 501](#).
- (3) Drain all fluid from the brake reservoir.
- (4) Disconnect the hydraulic line on the brake reservoir and attach a hydraulic hand pump capable of at least 0 - 2,500 psi.
- (5) Disconnect the hydraulic feed line at the left brake and attach a hydraulic pressure gauge with a minimum resolution of 50 psi and range of at least 3,000 psi to the hydraulic feed line.
  - Plug the port on the left brake to prevent contamination.
- (6) Disconnect the hydraulic feed line at the right brake and attach a hydraulic pressure gauge with a minimum resolution of 50 psi and range of at least 3,000 psi to the hydraulic feed line.
  - Plug the port on the right brake to prevent contamination.

---

**WARNING: THE MASTER CYLINDERS WILL BOOST THE PRESSURE APPLIED BY THE HAND PUMP TO THE BRAKES. THE REQUIRED PRESSURE FOR THIS TEST IS 2,250 TO 2,350 PSI AND SHOULD BE READ AT THE GAUGES ON THE BRAKES AND NOT THE GAUGE ON THE HAND PUMP. FAILURE TO COMPLY CAN RESULT IN BURSTING HYDRAULIC LINES AND INJURY TO PERSONNEL.**

- (7) Slowly operate the hydraulic hand pump until the gauges on the brakes read between 2,250 psi and 2,350 psi.
  - Record the pressure: \_\_\_\_\_
- (8) When the test pressure is achieved, close the hand pump shutoff valve and start stop watch.
  - Monitor the pressure for 5 minutes and verify the pressure does not decay more than 50 psi.
- (9) Open the hand pump shutoff valve and deplete the pressure to 0 psi.
- (10) Visually check every brake system line, fitting and connection in the left and right wheel wells and beneath the right floor boards in the cabin.
  - Verify that there is no leakage at any connection or fitting and record findings.
- (11) Disconnect the hydraulic pressure gauge hydraulic from the feed line at the right brake and attach the feed line to the right brake.
  - Torque to 30-40 lbf.in.
- (12) Disconnect the hydraulic pressure gauge hydraulic from the feed line at the left brake and attach the feed line to the right brake.
  - Torque to 30-40 lbf.in.
- (13) Disconnect the hydraulic line from the hydraulic hand pump and reconnect the line to the brake reservoir.
  - Torque to 40-60 lbf.in.
- (14) Service the hydraulic brake reservoir.
  - Refer to [AMM-12-10-02-061-801 – Brake - Servicing](#).
- (15) Visually check every brake system line, fitting, and connection in the left and right wheel wells and beneath the right floor boards, in the cabin. Verify that there is no leakage at any connection or fitting; record findings.

---

#### 4. Update DECU Configuration Settings

SUBTASK AMM-32-40-00-071-801-003-A

\*\*\* This subtask is applicable only to DECU D301102 when testing with the AMC

##### A. Setup

- (1) Before connecting all the pieces of equipment, verify the aircraft power is OFF.
- (2) Disconnect connector (32A30J01) from the DECU.
- (3) Connect the AMC to the DECU.
- (4) Power up the AMC.
- (5) On the AMC, select tab 32 Ldg Gear and then, from the drop-down box, ABS page.
- (6) Temporarily disconnect and reconnect the attached USB cable from the AMC and note the COM port number that is being assigned to this connection. This will be indicated on the bottom left of the AMC screen.

##### B. DECU Configuration

- (1) Apply power to the aircraft
- (2) Verify the following electronic circuit breakers (ECB) are
  - ABS = AUTO/ON
  - L BRAKE CTRL = PULLED
  - R BRAKE CTRL = PULLED
- (3) On the AMC ABS page, press “Config”. The 833812 ABS Configuration Tool window will appear.
- (4) In the Serial Port drop-down box, select COM port as previously noted.
- (5) Press “Connect” to establish communication with the DECU.
- (6) Verify the Connection Square indicator is lit green and Software Version is displayed; otherwise, repeat the previous step until successful.
- (7) In the ARINC and ABS Parameters sections, select the boxes as shown in [Fig. 502](#).
- (8) In the Aircraft Type drop-down box, select EA-500 as shown in [Fig. 502](#).
- (9) Press the “Program” button in the ABS Configuration Tool window.

**NOTE:** When the Program button is pressed, the Connection Square indicator briefly changes from green to yellow.

(10) Verify all the values match as shown in [Table 502](#).

**Table 502. ABS DECU Configuration Parameters**

PARAMETER	SETTING
ARINC Ch 1	High Speed
ARINC Ch 2	High Speed
ABS Parameters – Enabled	Checked
Disable Differential Braking	Not Checked
Aircraft Type	EA-500
Tire Rolling Radius	8.16
The skid target value, $F_T$	0.87
GPS time lag, $T_L$	0.625
The Optimum Deceleration Rate, $R_D$	8
Minimum Armed Speeds, $V_{MIN}$	15
Maximum Armed Speeds, $V_{MAX}$	255
Ch 1 (Right) Rotation	Clockwise
Ch 2 (Left) Rotation	Counter Clockwise

- (11) Reset the pulled ECBs and power down the aircraft.
- (12) Disconnect the AMC from the DECU.
- (13) Reconnect connector (32A30J01) to the DECU.

## 5. Update DECU Configuration Settings

SUBTASK AMM-32-40-00-071-801-003-B

\*\*\* This subtask is applicable only to testing DECU D303121 using config sw tool 463804-01

### A. Setup

- (1) Obtain 463804-01.exe from Eclipse Aerospace Service Engineering.
- (2) Power up the PC and copy 463804-01.exe on the desktop.
- (3) Before connecting all the pieces of equipment, verify the aircraft power is OFF.
- (4) Disconnect ship's harness connector 32A30J01 from the DECU.
- (5) Connect ship's harness connector 32A30J01) to DECU Configuration Harness J1.
- (6) Connect the DECU Configuration Harness connector P1 to the RS-232 to USB Adapter Cable.
- (7) Connect the RS-232 to USB Adapter Cable to the PC USB port.
- (8) On the PC, determine COM port designation.
  - (a) Start ->Control Panel ->Device Manager may be used.
- (9) Temporarily disconnect and reconnect the attached USB cable from the PC and note the COM port number that is being assigned to this connection.
- (10) Run 463804-01.exe. The 833812 ABS Configuration Tool window will appear.

### B. DECU Configuration

- (1) Apply power to the aircraft
- (2) Verify the following electronic circuit breakers (ECB) are
  - ABS = AUTO/ON
  - L BRAKE CTRL = PULLED
  - R BRAKE CTRL = PULLED
- (3) In the Serial Port drop-down box, select COM port as previously noted.
- (4) Press "Connect" to establish communication with the DECU.
- (5) Verify the Connection Square indicator is lit green and Software Version is displayed; otherwise, repeat the previous step until successful.
- (6) In the ARINC and ABS Parameters sections, select the boxes as shown in [Fig. 503](#).
- (7) In the Aircraft Type drop-down box, select EA-500 as shown in [Fig. 503](#).
- (8) Press the "Program" button in the ABS Configuration Tool window.

**NOTE:** When the Program button is pressed, the Connection Square indicator briefly changes from green to yellow.

- (9) Verify all the values match as shown in [Table 503](#).

**Table 503. ABS DECU Configuration Parameters**

PARAMETER	SETTING
ARINC Ch 1	High Speed
ARINC Ch 2	High Speed
ABS Parameters – Enabled	Checked
Disable Differential Braking	Not Checked
Aircraft Type	EA-500
Tire Rolling Radius	8.16
The skid target value, $F_T$	0.87
GPS time lag, $T_L$	0.625
Groundspeed Source	ARINC 1
ARINC Label	312
The Optimum Deceleration Rate, $R_D$	8
Minimum Armed Speeds, $V_{MIN}$	15
Maximum Armed Speeds, $V_{MAX}$	255
Ch 1 (Right) Rotation	Clockwise
Ch 2 (Left) Rotation	Counter Clockwise

- (10) Reset the pulled ECBs and power down the aircraft.  
 (11) Disconnect the AMC from the DECU.  
 (12) Reconnect connector (32A30J01) to the DECU.

---

## 6. Operational Checks

SUBTASK AMM-32-40-00-071-801-004

### A. **System Functional Checks**

- *Verify that Motor, Relay, Pressure Switch, Runaway Relay, and ABS ARMED Operate.*

- (1) On the MFD ECB synoptic page; pull the L BRAKE CTRL, R BRAKE CTRL and ABS ECB's.
- (2) Remove the Floor Panels (if installed) just aft of the DSU for access to the Digital Electronic Control Unit (DECU).
- (3) Disconnect connector (32A30J01) from the DECU.
- (4) Connect the ABS Functional Test Box to connector 23A30J01.
- (5) On the MFD ECB synoptic page; reset the L BRAKE CTRL, R BRAKE CTRL and ABS ECB's.
- (6) On the IPL; verify that the green ARMED light is illuminated.
- (7) Set the TEST BOX to OPEN; apply light force to the LH Brake Pedal.
  - In the Left Wing Wheel well; verify that the LH BCM runs (audible confirmation only), and then release the LH Brake Pedal.
- (8) Set the TEST BOX to OPEN; apply light force to the RH Brake Pedal.
  - In the Right Wing Wheel well; verify that the RH BCM runs (audible confirmation only), and then release the RH Brake Pedal.

**CAUTION:** DURING THE FOLLOWING STEPS, DO NOT HOLD THE SWITCH ON THE LEFT OR RIGHT POSITION FOR ANY LENGTH OF TIME, AS THIS WILL CAUSE HYDRAULIC FLUID TO OVERFLOW FROM THE MASTER CYLINDER RESERVOIR VENT.

- Momentarily set the TEST BOX to LEFT.
  - Verify that the LH Brake Pedal pushes back momentarily and the RH Brake Pedal remains steady. Also verify that the LH BCM Motor stops, while the RH BCM Motor continues to run.
  - Release Both Brake Pedals.
- (10) Apply moderate force to Both Brake Pedals.
    - Momentarily set the TEST BOX to RIGHT.
    - Verify that the RH Brake Pedal pushes back momentarily and the LH Brake Pedal remains steady. Also verify that the RH BCM Motor stops, while the LH BCM Motor continues to run.
    - Release Both Brake Pedals.
  - (11) On the MFD ECB synoptic page; pull the L BRAKE CTRL, R BRAKE CTRL and ABS ECB's.

- 
- (12) Disconnect connector 32A31P01 from the LH BCM and connector 32A32P01 from the RH BCM.
    - Connect the BCM TDR Test Harness to connectors 32A31P01 and 32A32P01.
    - Ensure TEST BOX switch is set to OPEN.
  - (13) On the MFD ECB synoptic page; reset the L BRAKE CTRL and ABS ECB's and start the Stop-Watch.
  - (14) Stop the stop-watch when the amber INOP light illuminates on the IPL (A time between 90 seconds and 150 seconds is acceptable). Record the time.
  - (15) On the MFD ECB synoptic page; pull the L BRAKE CTRL and ABS ECB's.
  - (16) On the MFD ECB synoptic page; reset the R BRAKE CTRL and ABS ECB's and start the Stop-Watch.
  - (17) Stop the stop-watch when the amber INOP light illuminates on the IPL (A time between 90 seconds and 150 seconds is acceptable). Record the time.
  - (18) On the MFD ECB synoptic page; pull the R BRAKE CTRL and ABS ECB's.
  - (19) Disconnect the 20-124719-\* BCM TDR Test Harness from connectors 32A31P01 and 32A32P01.
    - Reconnect connectors 32A31P01 and 32A32P01 to the LH BCM and RH BCM.
  - (20) Disconnect the TEST BOX from connector 32A30J01.
  - (21) Reconnect connector 32A30J01 to the DECU.
  - (22) On the MFD ECB synoptic page: reset the L BRAKE CTRL, R BRAKE CTRL and ABS ECB's.
  - (23) Using the Pilots Control Grip; press the ALL INTERRUPT Button.
    - Ensure that the amber INOP light illuminates on the IPL.
  - (24) Using the Co-Pilots Control Grip; press the ALL INTERRUPT Button.
    - Ensure that the amber INOP light illuminates on the IPL.
  - (25) Re-install floor panels.

**B. Control Functional Checks***• Check Controls and Indications*

- (1) Position the aircraft so that the GPS antenna has a clear view of the sky or can receive signals from a GPS repeater.
- (2) Connect a ground power cart to provide a standard 28 VDC to the aircraft.
- (3) Switch on the Battery Bus and Avionics Bus.
- (4) Verify that the GPS units have acquired satellites, the GS reads 0.0 knots, and the amber INTEG is not annunciated on the GPS displays.
- (5) Close circuit breakers L BCM, R BCM, and ABS.
- (6) Verify that the INOP and ARMED indicators illuminate for 2 seconds each, in sequence. If ABS INOP is illuminated continuously, push and release the ABS switch; observe the above 2 second flashes.
- (7) Verify that the amber ABS INOP and the blue ABS ARMED are dark.
- (8) Push the ABS switch and verify that the amber ABS INOP is illuminated and the blue ABS ARMED is dark.
- (9) Again, push the ABS switch and verify that the amber ABS INOP and the blue ABS ARMED are dark.

**C. Invalid ARINC 429 Functional Check***• Verify that Invalid A-429 Causes INOP Trip*

- (1) Pull (open) the circuit breakers for both GPS units.
- (2) Verify that the amber ABS INOP is flashing and that the blue ABS ARMED is dark.
- (3) Close the two GPS circuit breakers.
- (4) After the GS reads 0.0 knots, verify that the ABS INOP stops flashing and goes dark.

**D. Disconnected WST Functional Check***• Verify Disconnected WST Causes INOP Trip*

- (1) In the LH wheel well, disconnect 32A33P01; verify that the amber ABS INOP is flashing and that the blue ABS ARMED is dark.
- (2) Reconnect 32A33P01 and verify that the ABS INOP stops flashing and goes dark.
- (3) In the RH wheel well, disconnect 32A34P01; verify that the amber ABS INOP is flashing and that the blue ABS ARMED is dark.
- (4) Reconnect 32A34P01 and verify that the ABS INOP stops flashing and goes dark.
- (5) Testing Complete.

## 7. Troubleshooting

SUBTASK AMM-32-40-00-071-801-005

A. Refer to the following for troubleshooting:

**Table 504. Troubleshooting**

Symptom	Amber INOP indicator is illuminated.		
Steps	<b>Note: Open the three ABS ECBs anytime a connector is connected or disconnected or when measuring resistance. Also, when measuring voltage, close these ECBs.</b>		
1	Does INOP indicator go dark when the switch is pressed once?	YES	Done
	NO		
2	When the brake pedals are operated, does the ABS motor run (audible vibrating sound)?	YES	If the ARMED indicator does not illuminate during this step, the relay on the offending BCM is defective. Replace BCM and test system per AMM-32-40-00-071-801.
	NO		
3	Are any ABS ECBs Open?	YES	Close the 3 ABS ECBs, then go to Step 1.
	NO		
4	Does Pilot's PFD indicate a Ground Speed that is not 0.0 Knots?	YES	Verify that the #1 GPS is powered and the GPS antenna has a clear view of the sky, then go to step 1.
	NO		
5	At connector 32A30J01, does the measured resistance between pins 29 and 30, or 43 and 30 fall outside of 50 and 500 Ohms?	YES	Ring out wiring between this connector and connectors 32A32P01 and 32A31J01. If wiring is good, verify resistance of 50 to 500 Ohms, between pins D and E on BCM connector. If resistance check is bad, replace BCM and test system per AMM-32-40-00-071-801.
	NO		

Symptom	Amber INOP indicator is illuminated.		
Steps	<b>Note: Open the three ABS ECBs anytime a connector is connected or disconnected or when measuring resistance. Also, when measuring voltage, close these ECBs.</b>		
6	At connector 32A30J01, is the measured resistance between pins 22 and 30 less than 1,000 Ohms?	YES	Disconnect connector 91A03P01 and repeat Step 6. If resistance is now greater than 1,000 Ohms, replace switch and test system per AMM-32-40-00-071-801. If resistance is still less than 1,000 Ohms, the wiring between these two connectors is shorted to ground or the All Interrupt circuit is bad.
	NO		
7	Are connectors 32A34P01 and 32A33P01 undamaged and connected?	YES	Disconnect connectors 32A30P01, 32A34P01 and 32A33P01. Verify continuity of pins 24 to 3 and 30 to 1 for the two WST connectors, and 44 to 2 for the RH WST connector and 39 to 2 for the LH WST connector.
	NO		
8	If connections and wiring are good, per step 7, is the measured volts to pin 1 in connectors 32A34P01 and 32A33P01, less than 4.0 or greater than 6.0 volts?	YES	Replace DECU and test system per AMM-32-40-00-071-801.
	NO		
9	Is the measured resistance between pin 3 and ground greater than 10 ohms at connectors 32A34P01 and 32A33P01.	YES	Temporarily connect a new WST to the LH and RH connectors, in alternating fashion and repeat Step 1. If fault now clears, replace the offending WST. If the fault remains, the DECU is bad.
	NO		
10	INOP indicator not illuminated.	YES	Replace DECU per AMM-32-41-17-001-801 and AMM-32-41-17-041-801.

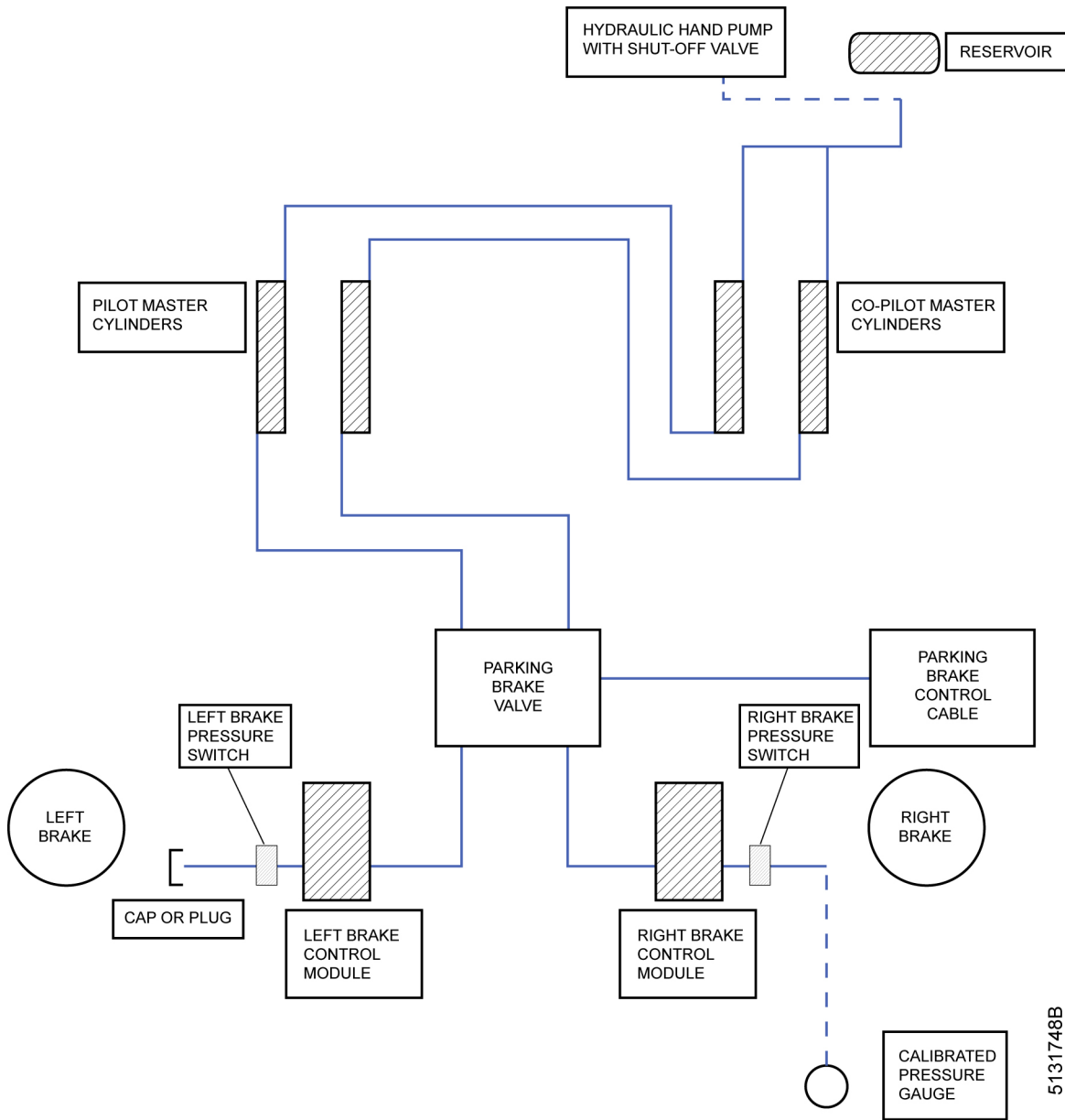

**On-Aircraft Proof Pressure Test Set-up  
Figure 501 (Sheet 1 of 1)**

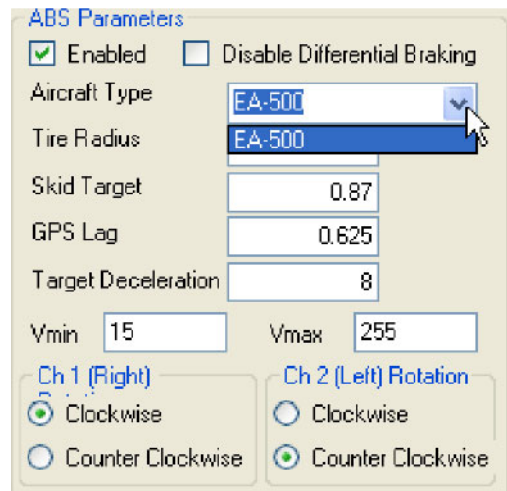
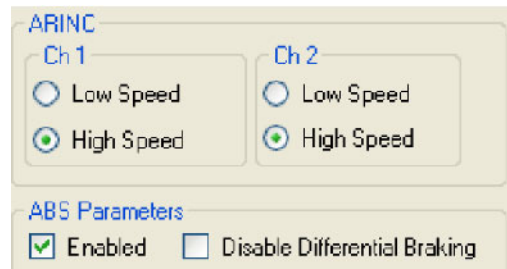

5141911A

**ARINC and ABS Parameters for DECU Configuration**  
**Figure 502 (Sheet 1 of 1)**  
\* \* \* Applicable only to DECU D301102 when testing with the AMC

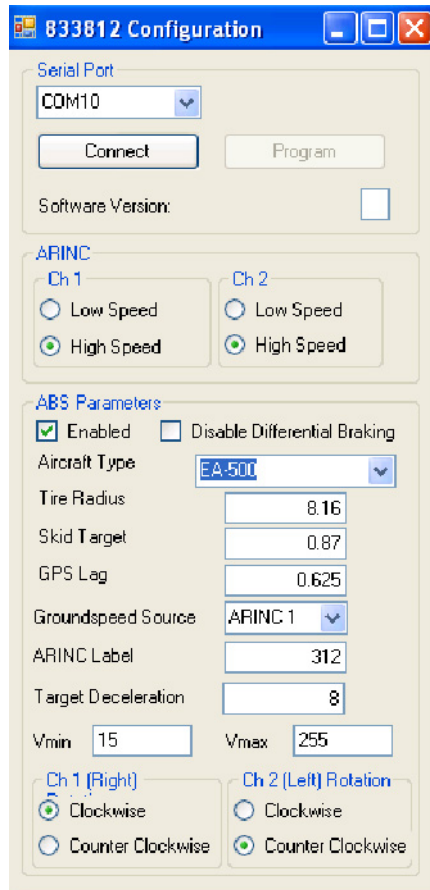

5202059A

**ARINC and ABS Parameters for DECU Configuration**  
**Figure 503 (Sheet 1 of 1)**

\*\*\* Applicable only to testing DECU D303121 using config sw tool 463804-01

THIS PAGE INTENTIONALLY LEFT BLANK