

CHAPTER - 34 HIGHLIGHTS (Summary of Changes)

Revision No. TR34-11 Sep 30/20

TO: HOLDERS OF THE AIRCRAFT MAINTENANCE MANUAL (06-123838)

Pages that have been added or revised are summarized below. Remove and insert the affected pages as listed, and enter the above revision number with issue date into the Record of Revisions sheet.

This Temporary Revision incorporates and supersedes previously released temporary revisions for the chapters listed below.

Do not remove this page. Keep it in place as a record of previous changes.

| CH/SE/SU Page Block No. | Description of Change |
|-----------------------------------|---|
| 34-10-00 PgBlk 501 | Corrected Standby Pitot/Static Probe Verification Test, SUBTASK AMM-34-11-00-071-701-006 for SDU. |
| 34-10-10 PgBlk 401-Rem (C) | Added auxiliary heaters to Pitot/AOA Probe - Removal - Config C. |
| 34-10-10 PgBlk 401-Inst (C) | Added auxiliary heaters to Pitot/AOA Probe - Installation - Config C. |
| 34-50-11 PgBlk 401-Rem | Corrected Figure 1. |
| 34-50-11 PgBlk 401-Inst | Corrected Figure 1. |
| 34-50-20 PgBlk 1 (A) | Revised Description and Operation – Config A. |
| 34-50-20 PgBlk 1 (B) | Added ADS-B Out to Description and Operation. – Config B. |
| 34-50-20 PgBlk 501 | Removed Barfield Altitude testing, Transponder and Avionics Cooling Fan Fault Checks (Standard System), and referenced Avionics Cooling Fan to AMM-34-50-24. Deleted Enhanced Downlinked Parameters test. Added ADS-B Test to test matrix. Added UC-584 antenna coupler to equipment table. Renamed existing procedures to with IFR-6000 Test Set Antenna. Added test procedures with UC-584 Antenna Coupler. |
| 34-50-21 PgBlk 501 | Added ADS-B Out check. Added antenna coupler to test. |
| 34-50-23 PgBlk 401-Inst | Installation – Revised Job Close-up test reference. |
| 34-50-24 PgBlk 501 | Adjustment/Test – Corrected circuit breaker labels. |

THIS PAGE INTENTIONALLY LEFT BLANK

FLIGHT ENVIRONMENT DATA - ADJUSTMENT/TEST

AMM-34-11-00-071-801

1. General

- A. This task gives procedures to do an adjustment/test of the flight environment data components.

NOTE: This test procedure complies with the requirements of 14 CFR Part 43 Appendix E.

- (1) Unless indicated differently, the adjustment/test procedures are the same for both left and right sides.
- (2) Included are procedures for use of both the Barfield Pitot/Static Tester (Barfield, DPS450) and the Barfield Pitot/Static Tester (Barfield, DPS500).
- (3) After a replacement of the left and right Pitot/AOA probes, static ports, Air Data Computers (ADCs), Standby Pitot/Static probe and Outside Air Temperature (OAT) probes, do the test for each component shown in the table below.

Table 501. Component Test Matrix

| Component to be Tested | Test |
|---------------------------------|---|
| Left and right ADCs | <i>Pitot and Static System Leak Test</i> SUBTASK AMM-34-11-00-071-701-001 , <i>Pitot and Static Verification Test</i> SUBTASK AMM-34-11-00-071-701-005 and <i>Angle of Attack Test</i> SUBTASK AMM-34-11-00-071-701-004 and AMM-24-00-00-071-801 – Electrical Power - Adjustment/Test , SUBTASK AMM-24-00-00-071-701-005 , Left and Right ADC Test. If software only is replaced, perform the following: <i>Pitot and Static Verification Test</i> SUBTASK AMM-34-11-00-071-701-005 . |
| Left and right Pitot/AOA probes | <i>Pitot and Static System Leak Test</i> SUBTASK AMM-34-11-00-071-701-001 , <i>Angle of Attack Test</i> SUBTASK AMM-34-11-00-071-701-004 and AMM-30-30-00-071-801 – Pitot and Static Anti-Ice System - Adjustment/Test . If software only is replaced, perform the following: <i>Pitot and Static System Leak Test</i> SUBTASK AMM-34-11-00-071-701-001 , and <i>Angle of Attack Test</i> SUBTASK AMM-34-11-00-071-701-004 . |
| Left and right Static ports | <i>Pitot and Static System Leak Test</i> SUBTASK AMM-34-11-00-071-701-001 and AMM-30-30-00-071-801 – Pitot and Static Anti-Ice System - Adjustment/Test . |

| Component to be Tested | Test |
|----------------------------|--|
| Standby Pitot/Static probe | <i>Standby Pitot/Static Probe System Leak Test</i> SUBTASK AMM-34-11-00-071-701-002 , <i>Standby Pitot/Static Probe Verification Test</i> SUBTASK AMM-34-11-00-071-701-006 and AMM-30-30-00-071-801 – Pitot and Static Anti-Ice System - Adjustment/Test . If software only is replaced, perform the following: <i>Standby Pitot/Static Probe Verification Test</i> SUBTASK AMM-34-11-00-071-701-006 . |
| Right and left OAT probes | <i>Outside Air Temperature Test</i> SUBTASK AMM-34-11-00-071-701-007 . |

2. Equipment and Materials

Table 502. Special Tools and Equipment

| Name and Part Number |
|--|
| Barfield Pitot/Static Tester (Barfield, DPS450) or Barfield Pitot/Static Tester (Barfield, DPS500) or Equivalent Tester. |
| Air Data Accessories Kit (NavAids P/N ADA500MD-945) (or) Air Data Accessories Kit ; (Nav Aids PN ADA500945) (Note: If using ADA500–945, covering pitot probes with tape is required) |
| Stop Watch (Inotek, EH365528) or Equivalent (Note: Calibrated with 1 second resolution) |
| Weight-on-Wheels (WOW) Box (EAI, 87-117390-1001). |
| Vinyl Tape (To cover drain hole on Pitot probes) |
| Ground Power Unit (GPU). AllStar 450 or AllStar G.S.E. or Hobart GPU-400 or Hobart GPU-600 or Bycan PS-28100 (Note: 28.0 ± 0.5 VDC) |

3. Job Set-Up

SUBTASK AMM-34-11-00-071-921-001

- A. Make aircraft safe for maintenance. Refer to [AMM-20-00-01-051-801 – Make Safe For Maintenance](#).
- B. Apply external power to the aircraft. Refer to [AMM-24-40-00-051-801 – External Power - Maintenance Practices](#).

CAUTION: IF TRANSPONDER(S) NOT SET TO “STBY”, THE AIRCRAFT WILL CAUSE NUISANCE TRANSPONDER TRANSMISSIONS TO THE LOCAL AIRFIELD AND OTHER AIRCRAFT.

- D. When performing tests with the Weight On Wheels (WOW) box, refer to [AMM-20-00-04-051-801 – Weight On Wheels \(WOW\) Box - Connect/Disconnect](#).
 - (1) Set both the left and right PFD Baro to 29.92 by pressing the BARO SET knob on the Autopilot Control Panel (ACP). Make sure the baro setting matches on the left and right PFD.
 - (2) Collar the following ECBs:

WARNING: BECAUSE THIS TEST IS PERFORMED WITH WOFFW, THE HEATERS WILL BE COMMANDED ON BY THE SYSTEM. IF THE PITOT/STATIC HEAT ECBs ARE NOT COLLARED OFF, HARM TO PERSONNEL OR DAMAGE TO AIR DATA TEST EQUIPMENT CAN OCCUR.

NOTE: ECBs can only be collared in the Weight-on-Wheels condition.

- (4) Collar the following ECB's:
 - ECB - WEATHER RADAR (L FWD Bus)
 - ECB - DEICE MANIFOLD HTR (R AFT Bus)
 - ECB - L PITOT HEAT (L FWD Bus) or ECB - L PITOT HEAT (BATT Bus)
 - ECB - R PITOT HEAT (R FWD Bus)
 - ECB - L STATIC HEAT (BATT Bus)
 - ECB - L STATIC HEAT (R FWD Bus)
 - ECB - R STATIC HEAT (R FWD Bus)
 - ECB - R STATIC HEAT (L FWD Bus)
 - ECB - STBY PITOT HEAT (BATT Bus) or ECB - STBY PITOT HEAT (L FWD)
 - ECB - L WINDSHIELD HEAT (L AFT Bus)
 - ECB - R WINDSHIELD HEAT (R AFT Bus)
- (5) Make sure that the ADC selection source is not displayed on the left PFD. Make sure that the ADC selection source is not displayed on the right PFD.

- (6) Set both the left and right PFD Baro to 29.92 by pressing the BARO SET knob on the Autopilot Control Panel (ACP). Make sure the baro setting matches on the left and right PFD.
- (7) Make sure that the ADC 3 is displayed on the MFD ADI.

CAUTION: IF TRANSPONDER(S) NOT SET TO “STBY”, THE AIRCRAFT WILL CAUSE NUISANCE TRANSPONDER TRANSMISSIONS TO THE LOCAL AIRFIELD AND OTHER AIRCRAFT.

4. **Pitot and Static System Leak Test**

SUBTASK AMM-34-11-00-071-701-001

CAUTION: DO NOT PRESSURIZE THE AIRCRAFT DURING TESTING.

NOTE: If a Barfield Pitot/Static Tester DPS450 is used for this test complete paragraph A. If a Barfield Pitot/Static Tester DPS500 is used, go to paragraph B.

A. Pitot and Static System Leak Test with Barfield Pitot/Static Tester DPS450:

Procedure is given for the left side and is the same for the right side.

Refer to [Fig. 501, Sheet 1](#).

CAUTION: DO NOT OVER TIGHTEN HOSES. DAMAGE MAY OCCUR TO TEST EQUIPMENT. HOSES SHOULD BE SNUG.

CAUTION: THE LEAK TEST CAN BE ACCOMPLISHED WITH ELECTRICAL POWER OFF. MAKE SURE THAT IF THE WOW BOX IS CONNECTED, THE SWITCHES ARE SET TO WONW DURING THIS TEST IF ELECTRICAL POWER IS USED. WITH WEIGHT OFF WHEELS, THE HEATERS ARE COMMANDED ON BY THE AIRCRAFT COMPUTER SYSTEM. IF THE PITOT/STATIC HEAT ECBS ARE NOT COLLARED OFF, HARM TO PERSONNEL OR AIR DATA TEST EQUIPMENT CAN OCCUR.

NOTE: Refer to step (1) if using Air Data Accessories Kit ; (Nav Aids PN ADA500945) or step (2) if using Air Data Accessories Kit (NavAids P/N ADA500MD-945).

- (1) Connect the Barfield Pitot/Static Tester DPS450 to the aircraft using the Air Data Accessories Kit ; (Nav Aids PN ADA500945) as follows:
 - (a) Install the Pitot/Angle of Attack (AOA) Probe Adaptor (Nav Aids, APA94520-4-4-4) (7) with the label TOP facing up on the Pitot/AOA probe. If needed, lubricate with Pitot adaptor lubricating fluid (Part Number LF5050).

Adjust the Pitot/AOA Probe Adaptor nozzles to align with the holes of the Pitot/AOA probe.

NOTE: No other lubricating fluid is permitted. Malfunction of the equipment in flight is possible.

NOTE: When installing the pressure test adapters, make sure that the seal is good by applying a firm force to seat the adapter on the probe.

NOTE: The Pitot/AOA probes with a drain hole near the base of mast, must have the drain hole covered. The drain hole must be covered with teflon or vinyl tape. Failure to do so will result in a failure of this test.

(b) Connect the Pitot Test Hose Assembly (long hose) (3) to the Pt connection (2) on the Barfield Pitot/Static Tester DPS450. Connect the other end of the long hose to the quick-connect cross (4).

(c) Connect the Pitot Test Hose Assembly (three short hoses) (5, 6 and 8) to the quick-connect cross. Connect the other end of the short hoses to the upper, center and lower connections on the Pitot/AOA Probe Adaptor (7).

NOTE: Make sure that the Pitot/AOA Probe Adaptor nozzles are still aligned with the holes on the Pitot/AOA probe.

(d) Connect the Static Port Adaptor (Nav Aids, SS53515-4-4) (10) to the left static port and finger tighten the screws to seat the seals over the static ports.

(e) Connect the Static Test Hose Assembly ; (Nav Aids PN E500-5160) (long hose) (12) to the Barfield Pitot/Static Tester DPS450 Ps connection (1). Connect the other end of the Static Test Hose Assembly to the quick connect cross (11).

(f) Connect the (short hose) (9) to the top fitting of the Static Port Adaptor (Nav Aids, SS53515-4-4) (10). Connect the other end of the short hose to the quick connect cross (11).

(2) Connect the Barfield Pitot/Static Tester DPS450 to the aircraft using the Air Data Accessories Kit (NavAids P/N ADA500MD-945) as follows:

NOTE: When installing the pressure test adapters, make sure that the seal is good by applying a firm force to seat the adapter on the probe.

NOTE: The P22201MD-4 adapter contains a built-in seal that covers the Pitot/AOA probe drain hole. If using the P22201-3 adapter, the drain hole must be covered with teflon or vinyl tape.

NOTE: The Pitot/AOA probes with a drain hole near the base of the mast, must have the drain hole covered. Failure to do so will result in a failure of this test.

(a) Connect the Pitot Test Hose Assembly (3) to the Pt connection (2) on the Barfield Pitot/Static Tester DPS450. DO NOT OVERTIGHTEN.

(b) Connect the opposite end of the hose to the NAV Aids P22201MD-4 adapter.

(c) Install the NAV Aids P22201MD-4 adapter to the Pitot/AOA Probe. Make sure that the internal seal of the adapter covers the pitot probe drain hole. If using the

P22201-3 adapter, make sure that the pitot probe drain hole is covered with tape. If needed, lubricate with Pitot adaptor lubricating fluid (Part Number LF5050).

NOTE: No other lubricating fluid is permitted. Malfunction of the equipment in flight is possible.

- (d) Connect the Static Port Adaptor (Nav Aids, SS53515-4-4) (10) to the left static port and finger tighten the screws to seat the seals over the static ports.
 - (e) Connect the Static Test Hose Assembly ; (Nav Aids PN E500-5160) (long hose) (12) to the Barfield Pitot/Static Tester DPS450 Ps connection (1).
 - (f) Connect the other end of the hose (9) to the top fitting of the Static Port Adaptor (Nav Aids, SS53515-4-4) (10).
- (3) Use tape to seal the opposite-side Static port.
- NOTE:** Make sure to select a tape that does not leave any adhesive residue on the static port when the test is complete.
- (4) Power on the Barfield Pitot/Static Tester DPS450. Wait for the Barfield Pitot/Static Tester DPS450 to the Confirm Settings.
- After a successful self-test sequence, the system changes to the Leak Measure mode.
- NOTE:** Skip this step if the Barfield Pitot/Static Tester DPS450 is in Quad mode. Quad mode displays four values: ALT, ROC, CAS, and Rt CAS.
- (5) Press Setup and press F1 to select Display. Press F3 to select Quad. Make sure that Alt is in ft, CAS is in kts and Rt CAS is in kts/min. If not, press F2 to select Units and then press F1 to select ft kts ft/min and press F4 to save settings. Press Clear/Quit to return to Main Menu displayed in the upper right corner.
 - (6) Press LEAK MEASURE/ CONTROL for CONTROL MODE.
 - (7) Press F1 to select Rate Timer and then press F3 to select Set Wait.
 - (8) Press 5 and then press Enter.
 - The Set Wait will be updated to 5 minutes.
 - (9) Press F4 to select Set Time, press 1, and then press Enter.
 - The Set Time will be updated to 1 minute.
 - (10) Press CLEAR/QUIT to return to Main Menu.
 - (11) Press ROC RATE Ps to select the ROC control aim, enter 4000 and press the Enter button.
 - (12) Press ALT Ps to select the ALT control aim, enter 30000 and press the Enter button.
 - The system starts to control to the new set point.
 - (13) Press SPEED Qc, enter 200 and press Enter. Wait for at least a 15 second stabilization period after the altitude and airspeed achieve these new air data parameter set point values to continue.
 - (14) Press LEAK MEASURE/CONTROL to change to LEAK MEASURE MODE.
 - (15) Press F1 twice to Start Timing.

- After the Waiting and Timing intervals are complete, the Barfield Pitot/Static Tester DPS450 displays Timed Rates Available.
- (16) Check that the maximum ROC is 100 ft/min or less and the maximum Rt CAS is 2 kts/min. or less.
- If the leak rate is not within tolerances, refer to Leak Testing in the Barfield Pitot/Static Tester DPS450 and Connecting Hoses ([SUBTASK AMM-34-11-00-071-701-003](#)). Subtract the Barfield Pitot/Static Tester DPS450 leak check altitude value recorded in Leak Testing in the Barfield Pitot/Static Tester DPS450 and Connecting Hoses subtask from the value obtained in this section in order to get a corrected total system leak value.
- (17) Press LEAK MEASURE/CONTROL to return to CONTROL MODE.
- (18) If no further maintenance is required, remove all of the Nav Aids test equipment from the aircraft. Stow the Air Data Accessories Kit ; (Nav Aids PN ADA500945) equipment and Barfield Pitot/Static Tester DPS450.
- (19) Remove the tape from the opposite-side Static port.

B. Pitot and Static System Leak Test with Barfield Pitot/Static Tester DPS500:

Procedure is given for the left side and is the same for the right side unless noted.

NOTE: To use the Barfield Pitot/Static Tester DPS500 Remote during this test, connect the Remote (P/N ADTS405-1728-37M0) and Remote Cord (P/N ADTS405-1728-28M0) to the Barfield Pitot/Static Tester DPS500 Hand Terminal Connection.

NOTE: The Pt Hose (p/n ADTS405-1729-62m0) may be used in place of the hose (p/n E500-7270). The AN6-AN4 adaptor is not needed if using the ADTS405-1729-62m0 Pt hose.

NOTE: The Ps Hose (p/n ADTS405-1729-61m0) may be used in place of the hose (p/n E500-5160), The AN6-AN4 connector is not required if using this configuration. Install a AN5 to AN4 adaptor on the Barfield DPS500 Ps connection.

CAUTION: DO NOT OVER TIGHTEN HOSES. DAMAGE MAY OCCUR TO TEST EQUIPMENT. HOSES SHOULD BE SNUG.

CAUTION: THE LEAK TEST CAN BE DONE WITH ELECTRICAL POWER OFF. MAKE SURE THAT IF THE WOW BOX IS CONNECTED, THE SWITCHES ARE SET TO WONW DURING THIS TEST IF ELECTRICAL POWER IS USED. WITH WEIGHT OFF WHEELS, THE HEATERS ARE COMMANDED ON BY THE AIRCRAFT COMPUTER SYSTEM. IF THE PITOT/STATIC HEAT ECBS ARE NOT COLLARED OFF, HARM TO PERSONNEL OR AIR DATA TEST EQUIPMENT CAN OCCUR.

NOTE: Refer to step (1) if using the Air Data Accessories Kit ; (Nav Aids PN ADA500945) or step (2) if using the Air Data Accessories Kit (NavAids P/N ADA500MD-945).

- (1) Connect the Barfield Pitot/Static Tester DPS500 to the aircraft as follows:
- (a) Install the Pitot/Angle of Attack (AOA) Probe Adaptor (Nav Aids, APA94520-4-4-4) (7) with the label TOP facing up on the Pitot/AOA probe. If

needed, lubricate with Pitot adaptor lubricating fluid (Part Number LF5050). Adjust the Pitot/AOA Probe Adaptor nozzles to align with the holes of the Pitot/AOA probe.

NOTE: No other lubricating fluid is allowed, possible malfunction of the equipment in flight is possible

NOTE: When installing the pressure test adapters, make sure of a good seal by applying a firm force to seat the adapter on the probe.

NOTE: If present, cover the probe drain hole with vinyl tape.

- (b) Connect the Pitot Test Hose Assembly (long hose) (3) to the Pt connection (2) on the Barfield Pitot/Static Tester DPS500. Connect the other end of the long hose (3) to the quick connect cross (4).
- (c) Connect the Pitot Test Hose Assembly (one short hose) (5) to the quick connect cross (4). Connect the other end of the short hose (5) to the center connection on the Pitot/AOA Probe Adaptor (7).

NOTE: Make sure that the Pitot/AOA Probe Adaptor nozzles are still aligned with the holes on the Pitot/AOA probe.

- (d) Connect the Static Test Hose Assembly ; (Nav Aids PN E500-5160) (12) to the Barfield Pitot/Static Tester DPS500 Ps connection (1).
- (e) Connect the other end of the Static Test Hose Assembly (12) to the top fitting of the Static Port Adaptor (Nav Aids, SS53515-4-4) (10).
- (f) Connect the Static Port Adaptor (Nav Aids, SS53515-4-4) (10) to the left Static port with the connected fitting to the top port and finger tighten the screws to seat the seals over the Static ports.

NOTE: The right static upper port can be tested from the left Static lower port by connecting the short hose to the lower port connection on the Static Port Adaptor. The aircraft's left lower port is connected to the right upper port and the left upper port is connected to the right lower port by aircraft design. Refer to [Fig. 504, Sheet 1](#).

- (2) Connect the Barfield Pitot/Static Tester DPS500 to the aircraft using the Air Data Accessories Kit (NavAids P/N ADA500MD-945) as follows:

NOTE: When installing the pressure test adapters, make sure that the seal is good by applying a firm force to seat the adapter on the probe.

NOTE: The P22201MD-4 adapter contains a built-in seal that covers the Pitot/AOA probe drain hole. If using the P22201-3 adapter, the drain hole must be covered with teflon or vinyl tape.

NOTE: The Pitot/AOA probes with a drain hole near the base of the mast, must have the drain hole covered. Failure to do so will result in a failure of this test.

- (a) Connect the Pitot Test Hose Assembly (3) to the Pt connection (2) on the Barfield Pitot/Static Tester DPS500. DO NOT OVERTIGHTEN.
- (b) Connect the opposite end of the hose to the NAV Aids P22201MD-4 adapter.
- (c) Install the NAV Aids P22201MD-4 adapter to the Pitot/AOA Probe. Make sure that the internal seal of the adapter covers the pitot probe drain hole. If using the

P22201-3 adapter, make sure that the pitot probe drain hole is covered with tape. If needed, lubricate with Pitot adaptor lubricating fluid (Part Number LF5050).

NOTE: No other lubricating fluid is permitted. Malfunction of the equipment in flight is possible.

- (d) Connect the Static Test Hose Assembly ; (Nav Aids PN E500-5160) (12) to the Barfield Pitot/Static Tester DPS500 Ps connection (1) .
 - (e) Connect the other end of the Static Test Hose Assembly (12) to the top fitting of the Static Port Adaptor (Nav Aids, SS53515-4-4) (10) .
 - (f) Connect the Static Port Adaptor (Nav Aids, SS53515-4-4) (10) to the left Static port with the connected fitting to the top port and finger tighten the screws to seat the seals over the Static ports.
- (3) Use tape to seal the opposite-side static port.
- NOTE:** Make sure to select a tape that does not leave any adhesive residue on the Static port when the test is complete.
- (4) Power on the Barfield Pitot/Static Tester DPS500 by selecting OPERATE and PUMP switches to ON. Wait for the Barfield Pitot/Static Tester DPS500 to confirm the settings.
- After a successful self-test sequence, the system changes to the Warm Up mode.
- (5) Press ROC Ps RATE to select the ROC control aim, enter 4000 and press the Enter button.
- (6) Press ALT Ps to select the ALT control aim, enter 30000 and press the Enter button.
- The system starts to control to the new set point.
- (7) Press SPEED Qc and enter 200 then press Enter. Wait for at least a 15 second stabilization period after the altitude and airspeed achieve these new air data parameter set point values to continue.
- (8) Press LEAK MEASURE/CONTROL to change to LEAK MEASURE MODE.
- (9) Press RATE TIMER.
- (10) Press F3.
- After the Waiting and Timing intervals are complete, the Barfield Pitot/Static Tester DPS500 displays Timed Rates.
- (11) Check that the maximum ROC is 100 ft/min or less and the maximum Rt CAS is 2 kts/min or less.
- If the leak rate is not within tolerances, refer to Leak Testing in the Barfield Pitot/Static Tester DPS500 and Connecting Hoses [SUBTASK AMM-34-11-00-071-701-003](#) and subtract the Barfield Pitot/Static Tester DPS500 leak check altitude value recorded in Leak Testing the Barfield Pitot/Static Tester DPS500 and Connecting Hoses subtask from the value obtained in this section in order to get a corrected total system leak value.
- (12) Press LEAK MEASURE/CONTROL to return to CONTROL MODE.

- (13) If no further maintenance is required, remove all of the Nav Aids test equipment from the aircraft. Stow all the Air Data Accessories Kit ; (Nav Aids PN ADA500945) equipment and the Barfield Pitot/Static Tester DPS500.
- (14) Remove the tape from the opposite-side Static port.

5. **Standby Pitot/Static Probe System Leak Test**

SUBTASK AMM-34-11-00-071-701-002

CAUTION: DO NOT PRESSURIZE THE AIRCRAFT DURING TESTING.

NOTE: If a Barfield Pitot/Static Tester DPS450 is used for this test complete paragraph A. If a Barfield Pitot/Static Tester DPS500 is used, go to paragraph B.

- A. Complete the Standby Pitot/Static System Leak Test (using the Barfield Pitot/Static Tester DPS450) as follows:

CAUTION: DO NOT OVER TIGHTEN HOSES. DAMAGE MAY OCCUR TO TEST EQUIPMENT. HOSES SHOULD BE SNUG.

CAUTION: THE LEAK TEST CAN BE ACCOMPLISHED WITH ELECTRICAL POWER OFF. MAKE SURE THAT IF THE WOW BOX IS CONNECTED, THE SWITCHES ARE SET TO WONW DURING THIS TEST IF ELECTRICAL POWER IS USED. WITH WEIGHT OFF WHEELS, THE HEATERS ARE COMMANDED ON BY THE AIRCRAFT COMPUTER SYSTEM. IF THE PITOT/STATIC HEAT ECBS ARE NOT COLLARED OFF, HARM TO PERSONNEL OR AIR DATA TEST EQUIPMENT CAN OCCUR.

NOTE: Refer to step (1) if using the Air Data Accessories Kit ; (Nav Aids PN ADA500945) or step (2) if using the Air Data Accessories Kit (NavAids P/N ADA500MD-945).

- (1) Connect the Barfield Pitot/Static Tester DPS450 to the aircraft Standby Pitot/Static probe as follows:
 - (a) Attach the Pitot/Static probe adaptor (PS35210-4-4) (6) to the Standby Pitot/Static probe.
 - (b) Connect the hose (3) from the Pt connection (2) on the Barfield Pitot/Static Tester DPS450 to the end fitting on the Pitot/Static probe adaptor (PS35210-4-4) (6) .
 - (c) Connect the hose from the Ps (1) connection on the Barfield Pitot/Static Tester DPS450 to the fitting on the side on the Pitot/Static probe adaptor (PS35210-4-4) (6) .

NOTE: Cover the probe drain hole with vinyl tape.
- (2) Connect the Barfield Pitot/Static Tester DPS500 to the aircraft using the Air Data Accessories Kit (NavAids P/N ADA500MD-945) as follows:
 - (a) Remove the P22201MD-4 adapter (or the P22201-3 adapter) from the Pt Hose. Connect the hose from the Pt adapter on the Barfield to PS35210MD-4-4 adapter

(or PS35210- 4-4 adapter) connector marked PITOT (this is the connector at the end of the adapter).

- (b) Disconnect the hose from the static PTA and connect to the other PS35210 connector (connector on side of adapter). Connect the PS35210 adapter to the Pitot/Static probe, make sure of a complete coverage of the static ports on the Pitot/Static probe.

NOTE: The PS35210MD-4-4 adapter contains a built-in seal that covers the pitot static probe drain hole. If using the PS35210-4-4 adapter, the drain hole must be covered with vinyl tape.

NOTE: The Pitot/Static probe is the upper pitot probe on the left hand side.

- (3) Press CLEAR/QUIT to return to main menu on Barfield Pitot/Static Tester DPS450.
- (4) Press F1 to select Rate Timer and then press F3 to select Set Wait.
- (5) Press 5 and then press ENTER.
 - The Set Wait will be updated to 5 minutes.
- (6) Press F4 to select Set Time, press 1, and then press ENTER.
 - The Set Time will be updated to 1 minute.
- (7) Press CLEAR/ QUIT to return to Main Menu.
- (8) Press LEAK MEASURE/ CONTROL for CONTROL MODE.
- (9) Press ROC RATE Ps to select the ROC control aim, enter 4000 and press Enter.
- (10) Press ALT Ps to select the ALT control aim, enter 30000 and press Enter.
 - The system starts to control to the new set point.
- (11) Press SPEED Qc, enter 200 and press Enter. Wait for at least a 15 second stabilization period after the altitude and airspeed achieve these new air data parameter set point values to continue.
- (12) Press LEAK MEASURE/CONTROL to change to LEAK MEASURE MODE.
- (13) Press F1 twice to Start Timing.
 - After the Waiting and Timing intervals are complete, the Barfield Pitot/Static Tester DPS450 displays Timed Rates Available.
- (14) Check the maximum ROC is 100 ft/min or less and the maximum Rt CAS is 2 kt/min or less.
 - If the leak rate is not within tolerances, refer to Leak Testing the Barfield Pitot/Static Tester DPS450 and Connecting Hoses ([SUBTASK AMM-34-11-00-071-701-003](#)) and subtract the Barfield Pitot/Static Tester DPS450 leak check altitude value recorded in Leak Testing the Barfield Pitot/Static Tester DPS450 and Connecting Hoses [SUBTASK AMM-34-11-00-071-701-003](#) from the value obtained in this section in order to get a corrected total system leak value.
- (15) Press the LEAK MEASURE/CONTROL to return to CONTROL MODE.

- (16) If no further maintenance is required, remove all of the Nav Aids test equipment from the aircraft. Stow the Air Data Accessories Kit ; (Nav Aids PN ADA500945) equipment and Barfield Pitot/Static Tester DPS450.
- B. Complete the Standby Pitot/Static System Leak Test (using the Barfield Pitot/Static Tester DPS500) as follows:

CAUTION: DO NOT OVER TIGHTEN HOSES. DAMAGE MAY OCCUR TO TEST EQUIPMENT. HOSES SHOULD BE SNUG.

CAUTION: THE LEAK TEST CAN BE ACCOMPLISHED WITH ELECTRICAL POWER OFF. MAKE SURE THAT IF THE WOW BOX IS CONNECTED, THE SWITCHES ARE SET TO WONW DURING THIS TEST IF ELECTRICAL POWER IS USED. WITH WEIGHT OFF WHEELS, THE HEATERS ARE COMMANDED ON BY THE AIRCRAFT COMPUTER SYSTEM. IF THE PITOT/STATIC HEAT ECBS ARE NOT COLLARED OFF, HARM TO PERSONNEL OR AIR DATA TEST EQUIPMENT CAN OCCUR.

NOTE: Refer to step (1) if using the Air Data Accessories Kit ; (Nav Aids PN ADA500945) or step (2) if using the Air Data Accessories Kit (NavAids P/N ADA500MD-945).

- (1) Connect the Barfield Pitot/Static Tester DPS450 to the aircraft Standby Pitot/Static probe as follows:
- (a) Attach the Pitot/Static probe adaptor (PS35210-4-4) (6) to the Standby Pitot/Static probe.
 - (b) Connect the hose (3) from the Pt connection (2) on the Barfield Pitot/Static Tester DPS450 to the end fitting on the Pitot/Static probe adaptor (PS35210-4-4) (6) .
 - (c) Connect the hose from the Ps (1) connection on the fitting on the side on the Pitot/Static probe adaptor (PS35210-4-4) (6) .

NOTE: Cover the probe drain hole with vinyl tape.

- (2) Connect the Barfield Pitot/Static Tester DPS500 to the aircraft using the Air Data Accessories Kit (NavAids P/N ADA500MD-945) as follows:
- (a) Remove the P22201MD-4 adapter (or the P22201-3 adapter) from the Pt Hose. Connect the hose from the Pt adapter on the Barfield to the PS35210MD-4-4 adapter (or PS35210- 4-4 adapter) connector marked PITOT (this is the connector at the end of the adapter).
 - (b) Disconnect the hose from the static PTA and connect to the other PS35210 connector (connector on the side of the adapter). Connect the PS35210 adapter to the Pitot/Static probe, make sure of complete coverage of the static ports on the Pitot/Static probe.

NOTE: The PS35210MD-4-4 adapter contains a built-in seal that covers the pitot static probe drain hole. If using the PS35210-4-4 adapter, the drain hole must be covered with vinyl tape.

NOTE: The Pitot/Static probe is the upper pitot probe on the left hand side.

- (3) Press LEAK MEASURE/ CONTROL for CONTROL MODE.
- (4) Press ROC RATE Ps to select the ROC control aim, enter 4000 and press Enter.
- (5) Press ALT Ps to select the ALT control aim, enter 30000 and press Enter.
 - The system starts to control to the new set point.
- (6) Press SPEED Qc and enter 200 then press ENTER. Wait for at least a 15 second stabilization period after the altitude and airspeed achieve these new air data parameter set point values to continue.
- (7) Press LEAK MEASURE/CONTROL to change to LEAK MEASURE MODE.
- (8) Press RATE TIMER.
- (9) .Press F3
 - After the Waiting and Timing intervals are complete, the DPS500 will display Timed Rates.
- (10) Check the maximum ROC is 100 ft/min or less and the maximum Rt CAS is 2 kt/min or less.
- (11) Press the LEAK MEASURE/CONTROL to return to CONTROL MODE.
- (12) If no further maintenance is required, remove all of the Nav Aids test equipment from the aircraft. Stow all the Air Data Accessories Kit ; (Nav Aids PN ADA500945) equipment and Barfield Pitot/Static Tester DPS500.

6. Leak Testing the Barfield Pitot/Static Tester DPS450 and Connecting Hoses.

SUBTASK AMM-34-11-00-071-701-003

- A. If leakage is excessive during the left and right Pitot and Static System Leak Test for unpressurized aircraft, do the following test with the Barfield Pitot/Static Tester DPS450:

CAUTION: DO NOT OVER TIGHTEN HOSES. DAMAGE MAY OCCUR TO TEST EQUIPMENT. HOSES SHOULD BE SNUG.

- (1) Connect the Nav Aids Hose E500-7270 (approximately 8 feet long) to the Barfield Pitot/Static Tester DPS450 Pt connector. Connect the other end of the E500-7270 to the Pitot/AOA pressure test hose fitting. Connect the pressure test hose fitting to the PT421-4520 Pre-Test Probe.
- (2) Connect the Nav Aids Hose E500-5160 (approximately 4 feet long) or (E500-5170 is acceptable) to the Barfield Pitot/Static Tester DPS450 Ps connector. Connect the other end of the E500-5160 to the Static Port Adaptor (Nav Aids, SS53515-4-4). Connect the Static Test Adaptor to the PTS515 Pre-Test Plate.
- (3) Power on the Barfield Pitot/Static Tester DPS450. Wait two minutes for the Barfield Pitot/Static Tester DPS450 to confirm the settings.
 - After a successful self-test sequence, the system changes to the Leak Measure mode.
- (4) Skip this step if the Barfield Pitot/Static Tester DPS450 is in Quad mode. Quad mode will display four values: Ps, RtPc, Qc, RtQc. Press SETUP, press F1 to select Display. Press F3 to select Quad. Make sure that Alt is in ft, CAS is in kts and Rt

CAS is in kts/min. If not, press F2 to select Units, press F1 to select ft Kts ft/min and press F4 to save settings. Press Clear/Quit to return to the Main Menu displayed in the upper right corner.

- (5) Press ALT Ps, ROC RATE Ps, SPEED Qc, and RATE to display the appropriate air data parameters.
- (6) Press CLEAR QUIT for the Main Menu displayed in the upper right corner. Several attempts of pressing the CLEAR/QUIT button may be needed to return to the Main Menu.
- (7) Press LEAK MEASURE/CONTROL to scroll to the CONTROL MODE displayed in lower left corner.
- (8) Press ROC RATE Ps to select the ROC control aim. Using the keypad, enter 4000 and press ENTER. Press ALT Ps to select the altitude control aim, enter 10000 and press ENTER.
 - The ROC and ALT control aim values will be updated.
- (9) Press SPEED Qc, enter 200 then press ENTER. Wait for at least a 15 second stabilization period after the ROC and CAS achieves the new air data parameter set points values before moving to the next step.
- (10) Press LEAK MEASURE/CONTROL to change to LEAK MEASURE MODE.
- (11) Press F1 to select Rate Timer and then press F3 to select Set Wait. Press 0.3 and then Enter.
- (12) Press F4 to select Set Time, press 0.3 and then ENTER.
 - The Set Wait and Set Time will both be updated to 00m.30s.
- (13) Press F1: Start Timer.
 - The display starts the count down Waiting timer followed by the Timing timer. After the Timing timer has expired, the ROC and Rt CAS will display Timed Leak Measure with the final values. Record these values.
 - Make sure that the ROC is less than ± 25 ft/min and Rt CAS is less than ± 0.25 kt/min.
- (14) Press CLEAR QUIT to return to the main menu.
- (15) Press LEAK MEASURE/CONTROL to return to CONTROL MODE.
- (16) Press GROUND to go to atmospheric pressure. Press F1 to select [Yes] to confirm.
- (17) After the Barfield Pitot/Static Tester DPS450 displays the SAFE AT GROUND prompt, power off the test set and remove the hose caps.
- (18) Return to the test section previously run to incorporate the values from Leak Testing the Barfield Pitot/Static Tester DPS450 and Connecting Hoses section.

7. Angle of Attack Test

SUBTASK AMM-34-11-00-071-701-004

NOTE: If a Barfield Pitot/Static Tester DPS450 is used for this test complete paragraph A. If a Barfield Pitot/Static Tester DPS500 is used, go to paragraph B.

A. Angle of Attack Test with the Barfield Pitot/Static Tester DPS450:

Procedure is given for the left side and is the same for the right side.

Refer to [Fig. 502, Sheet 1](#)

- (1) Connect the WOW Box to the aircraft and make sure that the ECBs are collared.
Refer to [SUBTASK AMM-34-11-00-071-921-001](#).
- (2) Select WOffW on the WOW test box.
- (3) Set the transponder to STBY on the PFD.
- (4) Make sure both the left and right PFD baro are set to 29.92 by using the BARO SET knob on the (ACP) Autopilot Control Panel. Also make sure that the baro setting matches on the left and right PFD.

NOTE: Refer to step (5) if using the Air Data Accessories Kit ; (Nav Aids PN ADA500945) or step (6) if using the Air Data Accessories Kit (NavAids P/N ADA500MD-945).

- (5) Connect the Barfield Pitot/Static Tester DPS450 to the aircraft using the Air Data Accessories Kit ; (Nav Aids PN ADA500945) as follows:

CAUTION: DO NOT OVER TIGHTEN HOSES. DAMAGE MAY OCCUR TO TEST EQUIPMENT. HOSES SHOULD BE SNUG.

NOTE: The Pitot/AOA probes with a drain hole near the base of mast, must have the drain hole covered. Failure to do so will result in a failure of this test.

- (a) Install the Pitot/Angle of Attack (AOA) Probe Adaptor (Nav Aids, APA94520-4-4-4) [\(7\)](#) with the label TOP facing up on the Pitot/AOA probe. If needed, lubricate with Pitot adaptor Lubricating fluid Part Number LF5050. Adjust the Pitot/AOA Probe Adaptor nozzles to align with the holes of the Pitot/AOA probe.
- (b) Connect the Pitot Test Hose Assembly (long hose) [\(3\)](#) to the Pt connection [\(2\)](#) on the Barfield Pitot/Static Tester DPS450. Connect the other end of the long hose [\(3\)](#) to the quick-connect cross [\(4\)](#).
- (c) Connect the Pitot Test Hose Assembly (two short hoses) [\(5 and 6\)](#) to the quick-connect cross [\(4\)](#). Connect the other ends of the two short hoses [\(5 and 6\)](#) to the center and lower connections on the Pitot/AOA Probe Adaptor [\(7\)](#).

NOTE: Make sure that the Pitot/AOA Probe Adaptor nozzles are still aligned with the holes on the Pitot/AOA probe.

- (6) Connect the Barfield Pitot/Static Tester DPS450 to the aircraft using the Air Data Accessories Kit (NavAids P/N ADA500MD-945) as follows:
 - (a) Remove the PS35210 Pressure Test Adaptor from the Pitot/Static probe.

-
- (b) Remove the E500-7270 hose from the PITOT (end) connector of the PS35210 adapter and connect to a NAV Aids quick connect cross (leave other end of hose connected to the Barfield Pt connector). Connect (2) LH and/or RH MFP Pitot hoses approximately 2 ft long to the quick disconnect cross and then to the Middle and Lower Nozzles of the NAV Aids APA94520MD-4-4-4 (or APA94520-4-4-4) Pressure Test Adaptor.
 - (c) Connect another LH and/or RH MFP pitot hose approximately 2 ft long to the upper nozzle of the APA94250 adapter. Connect the other end to a second NAV Aids quick connect cross.
 - (d) Remove the other hose from the PS35210 pitot/static test adaptor and connect it to the same quick connect cross as the upper hose of the APA94520 adapter.
 - (e) Attach an E500-5160 hose to the upper static test adaptor. Attach the other end of the hose to the quick connect cross that is connected to the upper hose of the APA94520 Pitot/AOA test adaptor.
 - (f) If needed Lubricate with Pitot adaptor Lubricating fluid Part # LF5050 (NOTE: No other lubricating fluid is allowed) Insert an APA94520 adapter onto the Left Pitot probe and adjust the PTA nozzles to align with the holes of the Pitot/AOA Probe and adjust until the seals are snug. (DO NOT over tighten)
- (7) Power on the Barfield Pitot/Static Tester DPS450 (if needed).
 - Wait for the Barfield Pitot/Static Tester DPS450 to finish a sequence of pneumatic and internal system checks and the system changes to the Leak Measure mode (shown, lower left display corner).
 - (8) Press LEAK MEASURE/CONTROL to select the CONTROL MODE.
 - (9) Press ALT Ps, enter 6000, and press Enter.
 - (10) Select F2 UNITS then select F3 inHg.
 - Units on the display change from kts/min to inHg.
 - (11) Press SPEED Qc, enter 0.5 inHg, and press Enter.
 - Wait for at least a 15 second stabilization period after the Barfield achieves this new air data set point value (within ± 2 feet & and ± 0.010 inHg).
 - (12) Record the airspeed on the left PFD.
 - Expected results are 105.5 kts \pm 2.5 kts.
 - (13) Press GROUND to go to the atmospheric pressure. Press F1 to select Yes to confirm.
 - The Barfield Pitot/Static Tester DPS450 displays shows for SAFE AT GROUND.
 - (14) Power off the Barfield Pitot/Static Tester DPS450.
 - (15) If no further maintenance is required, remove all of the Nav Aids test equipment from the aircraft. Stow the Air Data Accessories Kit equipment and Barfield Pitot/Static Tester DPS450. Also, refer to [SUBTASK AMM-34-11-00-071-921-002](#).
- B. Angle of Attack Test with the Barfield Pitot/Static Tester DPS500:
Procedure is given for the left side and is the same for the right side.

- (1) Connect the WOW Box to the aircraft and make sure that the ECBs are collared. Refer to [SUBTASK AMM-34-11-00-071-921-001](#).
- (2) Select WOffW on the WOW test box.
- (3) Set the transponder to STBY on the PFD.
- (4) Make sure both the left and right PFD baro are set to 29.92 by using the BARO SET knob on the ACP. Make sure the baro setting matches on the left and right PFD.

NOTE: Refer to step (4) if using the Air Data Accessories Kit ; (Nav Aids PN ADA500945) or step (5) if using the Air Data Accessories Kit (NavAids P/N ADA500MD-945).

- (5) Connect the Barfield Pitot/Static Tester DPS500 to the aircraft using the Air Data Accessories Kit ; (Nav Aids PN ADA500945) as follows:

CAUTION: DO NOT OVER TIGHTEN HOSES. DAMAGE MAY OCCUR TO TEST EQUIPMENT. HOSES SHOULD BE SNUG.

NOTE: The Pitot/AOA probes with a drain hole near the base of mast, must have the drain hole covered. Failure to do so will result in a failure of this test.

NOTE: The Pt Hose (ADTS405-1729- 62m0) may be used in place of the hose (E500-7270). An AN6 – AN4 adaptor is not needed if using the ADTS405-1729-62m0 Pt hose.

- (a) Install the Pitot/Angle of Attack (AOA) Probe Adaptor (Nav Aids, APA94520-4-4-4) (7) with the label TOP facing up on the Pitot/AOA probe. If needed, lubricate with Pitot adaptor Lubricating fluid Part Number LF5050. Adjust Pitot/AOA Probe Adaptor nozzles to align with the holes of the Pitot/AOA probe.
- (b) Connect the Pitot Test Hose Assembly (long hose) (3) to the Pt connection (2) on the Barfield Pitot/Static Tester DPS500. Connect the other end of the long hose (3) to the quick-connect cross (4) .
- (c) Connect the Pitot Test Hose Assembly (two short hoses) (5 and 6) to the quick-connect cross (4) . Connect the other ends of the two short hoses (5 and 6) to the center and lower connections on the Pitot/AOA Probe Adaptor (7) .

NOTE: Make sure that the Pitot/AOA Probe Adaptor nozzles are still aligned with the holes on the Pitot/AOA probe.

- (6) Connect the Barfield Pitot/Static Tester DPS500 to the aircraft using the Air Data Accessories Kit (NavAids P/N ADA500MD-945) as follows:
 - (a) Remove the PS35210 Pressure Test Adaptor from the Pitot/Static probe.
 - (b) Remove the E500-7270 hose from the PITOT (end) connector of the PS35210 adaptor and connect to a NAV Aids quick connect cross (leave other end of hose connected to the Barfield Pt connector). Connect (2) LH and/or RH MFP Pitot hoses approximately 2 ft long to the quick disconnect cross and then to the Middle and Lower Nozzles of the NAV Aids APA94520MD-4-4-4 (or APA94520-4-4-4) Pressure Test Adaptor.

- (c) Connect another LH and/or RH MFP pitot hose approximately 2 ft long to the upper nozzle of the APA94250 adapter. Connect the other end to a second NAV Aids quick connect cross.
 - (d) Remove the other hose from the PS35210 pitot/static test adaptor and connect it to the same quick connect cross as the upper hose of the APA94520 adapter.
 - (e) Attach an E500-5160 hose to the upper static test adaptor. Attach the other end of the hose to the quick connect cross that is connected to the upper hose of the APA94520 Pitot/AOA test adaptor.
 - (f) If needed Lubricate with Pitot adaptor Lubricating fluid Part # LF5050 (NOTE: No other lubricating fluid is allowed) Insert the APA94520 adapter onto the Left Pitot probe and adjust the PTA nozzles to align with the holes of the Pitot/AOA Probe and adjust until the seals are snug. (DO NOT over tighten)
- (7) Power on the Barfield Pitot/Static Tester DPS500 by flipping the Operate & Pump toggle switches.
 - Wait for the Barfield Pitot/Static Tester DPS500 to finish a sequence of pneumatic and internal system checks and the system changes to the Leak Measure mode (shown, lower left display corner).
 - (8) Press LEAK MEASURE/CONTROL to select the CONTROL MODE.
 - (9) Press ALT Ps, enter 6000, and press Enter.
 - (10) Press SETUP.
 - Units on the display change from kts/min to inHg.
 - (11) Press F1 (UNITS).
 - (12) Press F1 (Next) 6 times until inHg is displayed.
 - (13) Press F4 (Save).
 - (14) Press CLEAR QUIT twice
 - (15) Press SPEED Qc, enter 0.5 inHg, and press Enter.
 - Wait for at least a 15 second stabilization period after the Barfield Pitot/Static Tester DPS500 achieves this new air data set point value to continue.
 - (16) Record the airspeed on the left PFD.
 - Expected results are 105.5 knots \pm 2.5 kts.
 - (17) Press GROUND to go to atmospheric pressure. Press F1 to select Yes to confirm.
 - The Barfield Pitot/Static Tester DPS500 displays shows for SAFE AT GROUND.
 - (18) Press CLEAR QUIT.
 - (19) Power off the Barfield Pitot/Static Tester DPS500.
 - (20) If no further maintenance is required, remove all of the Nav Aids test equipment from the aircraft. Stow all air data equipment and the Barfield Pitot/Static Tester DPS450. Also, refer to [SUBTASK AMM-34-11-00-071-921-002](#).

8. Pitot and Static Verification Test

SUBTASK AMM-34-11-00-071-701-005

NOTE: If a Barfield Pitot/Static Tester DPS450 is used for this test complete paragraph A. If a Barfield Pitot/Static Tester DPS500 is used, go to paragraph B.

A. Pitot and Static Verification Test with Barfield Pitot/Static Tester DPS450:

Procedure is given for the left side and is the same for the right side unless noted.

Refer to [Fig. 501, Sheet 1](#)

- (1) Connect the WOW Box to the aircraft and make sure that the ECBs are collared.
Refer to [SUBTASK AMM-34-11-00-071-921-001](#).
- (2) Set the WOW Box switches to WOnW.
- (3) Power up the aircraft by setting the SYS BATT and START BATT switches to ON and the BUS TIE switch to AUTO.

CAUTION: DO NOT OVER TIGHTEN HOSES. DAMAGE MAY OCCUR TO TEST EQUIPMENT. HOSES SHOULD BE SNUG.

NOTE: Refer to step (4) if using the Air Data Accessories Kit ; (Nav Aids PN ADA500945) or step (5) if using the Air Data Accessories Kit (NavAids P/N ADA500MD-945).

- (4) Connect the Barfield Pitot/Static Tester DPS450 to the aircraft using the Air Data Accessories Kit ; (Nav Aids PN ADA500945) as follows:
 - (a) Install the Pitot/Angle of Attack (AOA) Probe Adaptor (Nav Aids, APA94520-4-4-4) [\(7\)](#) with the label TOP facing up on the Pitot/AOA probe. If needed, lubricate with Pitot adaptor lubricating fluid (Part Number LF5050). Adjust the Pitot/AOA Probe Adaptor nozzles to align with the holes of the Pitot/AOA probe.

NOTE: No other lubricating fluid is allowed, possible malfunction of the equipment in flight is possible.

NOTE: When installing the pressure test adapters, make sure that the seal is good by applying a firm force to seat the adapter on the probe.
 - (b) Connect the Pitot Test Hose Assembly (long hose) [\(3\)](#) to the Pt connection [\(2\)](#) on the Barfield Pitot/Static Tester DPS450. Connect the other end of the long hose [\(3\)](#) to the quick-connect cross [\(4\)](#) .
 - (c) Connect the Pitot Test Hose Assembly (three short hoses) [\(5,6 and 8\)](#) to the quick-connect cross [\(4\)](#) . Connect the other ends of the three short hoses [\(5,6 and 8\)](#) to the upper, center and lower connections on the Pitot/AOA Probe Adaptor [\(7\)](#) .

NOTE: Make sure that the Pitot/AOA Probe Adaptor nozzles are still aligned with the holes on the Pitot/AOA probe.
 - (d) Connect the Static Test Hose Assembly ; (Nav Aids PN E500-5160) (long hose) [\(12\)](#) to the Barfield Pitot/Static Tester DPS450 Ps connection. Connect the other end of the long hose [\(12\)](#) to the quick-connect cross [\(11\)](#) . Connect the static

short hose (9) to the top fitting of the Static Port Adaptor (Nav Aids, SS53515-4-4) (10).

- (e) Connect the Static Port Adaptor (Nav Aids, SS53515-4-4) (10) to the left Static port with the connected fitting to the top port and finger tighten the screws to seat the seals over the Static ports.
- (5) Connect the Barfield Pitot/Static Tester DPS450 to the aircraft using the Air Data Accessories Kit (NavAids P/N ADA500MD-945) as follows:
- NOTE:** When installing the pressure test adapters, make sure that the seal is good by applying a firm force to seat the adapter on the probe.
- NOTE:** The P22201MD-4 adapter contains a built-in seal that covers the Pitot/AOA probe drain hole. If using the P22201-3 adapter, the drain hole must be covered with teflon or vinyl tape.
- NOTE:** The Pitot/AOA probes with a drain hole near the base of mast, must have the drain hole covered. Failure to do so will result in a failure of this test.
- (a) Connect the Pitot Test Hose Assembly (3) to the Pt connection (2) on the Barfield Pitot/Static Tester DPS450. DO NOT OVERTIGHTEN.
- (b) Connect the opposite end of the hose to the NAV Aids P22201MD-4 adapter.
- (c) Install the NAV Aids P22201MD-4 adapter to the Pitot/AOA Probe. Make sure that the internal seal of the adapter covers the pitot probe drain hole. If using the P22201-3 adapter, make sure that the pitot probe drain hole is covered with tape. If needed, lubricate with Pitot adaptor lubricating fluid (Part Number LF5050).
- NOTE:** No other lubricating fluid is permitted. Malfunction of the equipment in flight is possible.
- (d) Connect the Static Port Adaptor (Nav Aids, SS53515-4-4) (10) to the left static port and finger tighten the screws to seat the seals over the static ports.
- (e) Connect the Static Test Hose Assembly ; (Nav Aids PN E500-5160) (long hose) (12) to the Barfield Pitot/Static Tester DPS450 Ps connection (1).
- (f) Connect the other end of the hose (9) to the top fitting of the Static Port Adaptor (Nav Aids, SS53515-4-4) (10).
- (6) Use tape to seal the opposite-side static port.
- NOTE:** Make sure to select a tape that does not leave any adhesive residue on the Static port when the test is complete.
- (7) Select WOffW on the WOW test box.
- (8) Set the transponder to STBY on the PFD.
- (9) If required, set both the left and right PFD baro to 29.92 by using the BARO SET knob on the ACP.
- Make sure that the baro setting matches on the left and right PFD and the SDU.
- (10) Turn on the Barfield Pitot/Static Tester DPS450.
- (11) Set the Barfield Pitot/Static Tester DPS450 static pressure to 40,613 feet and set the airspeed to 159.2 knots as follows:

-
- (a) Press ALT Ps to select the ALT control aim, enter 40613 and press ENTER. Press SPEED Qc, enter 159.2 and press ENTER. Wait for at least a 15 second stabilization period after the altitude and airspeed achieve these new air data parameter set point values to continue.
- (12) Record the left PFD altimeter and airspeed.
- Expected results are 41,000 ± 40 feet, 160 ± 2.5 knots, and 0.575 ± 0.008 Mach.
- (13) Set the Barfield Pitot/Static Tester DPS450 static pressure to 29,698 feet and increase the airspeed to 199.3 knots as follows:
- (a) Press ALT Ps to select the ALT control aim, enter 29698 and press Enter. Press SPEED Qc, enter 199.3 and press ENTER. Wait for at least a 15 second stabilization period after the altitude and airspeed achieve these new air data parameter set point values to continue.
- (14) Record the left PFD altitude and airspeed.
- Expected results are 30,000 ± 40 feet, 200 ± 2.7 knots and 0.557 ± 0.006 Mach.
- (15) Set the Barfield Pitot/Static Tester DPS450 static pressure to 19,706 feet and increase the airspeed to 237.6 knots as follows:
- (a) Press ALT Ps to select the ALT control aim, enter 19706 and press Enter. Press SPEED Qc, enter 237.6 and press ENTER. Wait for at least a 15 second stabilization period after the altitude and airspeed achieve these new air data parameter set point values to continue.
- (16) Record the left PFD altitude and airspeed.
- Expected results are 20,000± 40 feet, 240 ± 3 knots and 0.535 ± 0.006 Mach.
- (17) Set the Barfield Pitot/Static Tester DPS450 static pressure to 9,872 feet set the airspeed to 195.9 knots as follows:
- (a) Press ALT Ps to select the ALT control aim, enter 9872" and press Enter. Press SPEED Qc, enter 195.9 and press Enter. Wait for at least a 15 second stabilization period after the altitude and airspeed achieve these new air data parameter set point values to continue.
- (18) Record the left PFD altitude and airspeed.
- Expected results are 10,000± 33 feet and 200 ± 2.7 knots.
- (19) Set the Barfield Pitot/Static Tester DPS450 static pressure to 6,008 feet and set the airspeed to 66.1 knots as follows:
- (a) Press ALT Ps to select the ALT control aim, enter 6008 and press Enter. Press SPEED Qc, enter 66.1 and press Enter. Wait for at least a 15 second stabilization period after the altitude and airspeed achieve these new air data parameter set point values to continue.
- (20) Record the left PFD altimeter and airspeed.
- Expected results are 6,000 ± 25 feet and 65 ± 2 knots.
- (21) Press GROUND to go to atmospheric pressure. Press F1 to select Yes to confirm.
- (a) If the Barfield Pitot/Static Tester DPS450 is not in CONTROL MODE, press LEAK MEASURE/CONTROL.

- (b) After the Barfield Pitot/Static Tester DPS450 displays shows SAFE AT GROUND prompt, power off the Barfield Pitot/Static Tester DPS450.
 - (22) Select WOnW on the WOW test box.
 - (23) Make sure that all of the Pitot and Static heat ECB's are collared.
 - (24) If no further maintenance is required, remove all of the Nav Aids test equipment from the aircraft. Stow all air data equipment and Barfield Pitot/Static Tester DPS450. Also, refer to [SUBTASK AMM-34-11-00-071-921-002](#).
- B. Pitot and Static Verification Test with the Barfield Pitot/Static Tester DPS500:
Procedure is given for the left side and is the same for the right side unless specified.
- (1) Connect the WOW Box to the aircraft and make sure that the ECBs are collared. Refer to [SUBTASK AMM-34-11-00-071-921-001](#).
 - (2) Set the WOW Box switches to WOnW.
 - (3) Power up the aircraft by setting the SYS BATT and START BATT switches to ON and the BUS TIE switch to AUTO.

CAUTION: DO NOT OVER TIGHTEN HOSES. DAMAGE MAY OCCUR TO TEST EQUIPMENT. HOSES SHOULD BE SNUG.

NOTE: Refer to step (4) if using the Air Data Accessories Kit ; (Nav Aids PN ADA500945) or step (5) if using the Air Data Accessories Kit (NavAids P/N ADA500MD-945) - un.

- (4) Connect the Barfield Pitot/Static Tester DPS500 to the aircraft using the Air Data Accessories Kit ; (Nav Aids PN ADA500945) as follows:
 - (a) Install the Pitot/Angle of Attack (AOA) Probe Adaptor (Nav Aids, APA94520-4-4-4) (7) with the label TOP facing up on the Pitot/AOA probe. If needed, lubricate with Pitot adaptor lubricating fluid (Part Number LF5050). Adjust the Pitot/AOA Probe Adaptor nozzles to align with the holes of the Pitot/AOA probe.

NOTE: No other lubricating fluid is permitted. Malfunction of the equipment in flight is possible.

NOTE: When installing the pressure test adapters, make sure that the seal is good by applying a firm force to seat the adapter on the probe.
 - (b) Connect the Pitot Test Hose Assembly (long hose) (3) to the Pt connection (2) on the Barfield Pitot/Static Tester DPS500. Connect the other end of the long hose (3) to the quick-connect cross (4) .
 - (c) Connect the Pitot Test Hose Assembly (three short hoses) (5,6 and 8) to the quick-connect cross (4) . Connect the other ends of the three short hoses (5,6 and 8) to the upper, center and lower connections on the Pitot/AOA Probe Adaptor (7) .

NOTE: Make sure that the Pitot/AOA Probe Adaptor nozzles are still aligned with the holes on the Pitot/AOA probe.
 - (d) Connect the Static Test Hose Assembly ; (Nav Aids PN E500-5160) (long hose) (12) to the Barfield Pitot/Static Tester DPS500 Ps connection. Connect other end

of long hose (12) to the quick-connect cross (11) . Connect the static short hose (9) to the top fitting of the Static Port Adaptor (Nav Aids, SS53515-4-4) (10) .

- (e) Connect the Static Port Adaptor (Nav Aids, SS53515-4-4) (10) to the left static port with the connected fitting to the top port and finger tighten the screws to seat the seals over the static ports.

NOTE: The right static upper port can be tested from the left static lower port by connecting the short hose to the lower port connection on the Static Port Adaptor. The aircraft's left lower port is connected to the right upper port and the left upper port is connected to the right lower port by aircraft design. Refer to [Fig. 503, Sheet 1](#)

- (5) Connect the Barfield Pitot/Static Tester DPS500 to the aircraft using the Air Data Accessories Kit (NavAids P/N ADA500MD-945) as follows:

NOTE: When installing the pressure test adapters, make sure that the seal is good by applying a firm force to seat the adapter on the probe.

NOTE: The P22201MD-4 adapter contains a built-in seal that covers the Pitot/AOA probe drain hole. If using the P22201-3 adapter, the drain hole must be covered with teflon or vinyl tape.

NOTE: The Pitot/AOA probes with a drain hole near the base of mast, must have the drain hole covered. Failure to do so will result in a failure of this test.

- (a) Connect the Pitot Test Hose Assembly (3) to the Pt connection (2) on the Barfield Pitot/Static Tester DPS500. DO NOT OVERTIGHTEN.
- (b) Connect the opposite end of the hose to the NAV Aids P22201MD-4 adapter.
- (c) Install the NAV Aids P22201MD-4 adapter to the Pitot/AOA Probe. Make sure that the internal seal of the adapter covers the pitot probe drain hole. If using the P22201-3 adapter, make sure that the pitot probe drain hole is covered with tape. If needed, lubricate with Pitot adaptor lubricating fluid (Part Number LF5050)..

NOTE: No other lubricating fluid is permitted. Malfunction of the equipment in flight is possible.

- (d) Connect the Static Test Hose Assembly ; (Nav Aids PN E500-5160) (12) to the Barfield Pitot/Static Tester DPS500 Ps connection (1) .
- (e) Connect the other end of the Static Test Hose Assembly (12) to the top fitting of the Static Port Adaptor (Nav Aids, SS53515-4-4) (10) .
- (f) Connect the Static Port Adaptor (Nav Aids, SS53515-4-4) (10) to the left Static port with the connected fitting to the top port and finger tighten the screws to seat the seals over the Static ports.

- (6) Use tape to seal the opposite-side static port.

NOTE: Make sure to select a tape that does not leave any adhesive residue on the static port when the test is complete.

- (7) Select WOffW on the WOW test box.
- (8) Set the transponder to STBY on the PFD.
- (9) Set both the left and right PFD Baro to 29.92 by using the BARO SET knob on the ACP.

- Make sure the baro setting matches on the left and right PFD.
- (10) Power on the Barfield Pitot/Static Tester DPS500 by selecting OPERATE and PUMP switches to ON. Wait for the Barfield Pitot/Static Tester DPS500 to Confirm Settings.
 - After a successful self-test sequence, the system changes to the Warm Up mode.
 - (11) Set the Barfield Pitot/Static Tester DPS500 static pressure to 40,613 feet and set the airspeed to 159.2 knots as follows:
 - (a) Press ALT Ps to select the ALT control aim, enter 40613 and press Enter. Press SPEED Qc, enter 159.2 and press ENTER. Wait for at least a 15 second stabilization period after the altitude and airspeed achieve these new air data parameter set point values to continue.
 - (12) Record the left PFD altitude and airspeed.
 - Expected results are 41,000 ± 40 feet, 160 ± 2.5 knots and 0.575 ± 0.008 Mach.
 - (13) Set the Barfield Pitot/Static Tester DPS500 static pressure to 29,698 feet and increase airspeed to 199.3 knots as follows:
 - (a) Press ALT Ps to select the ALT control aim, enter 29698 and press Enter. Press SPEED Qc, enter 199.3 and press Enter. Wait for at least a 15 second stabilization period after the altitude and airspeed achieve these new air data parameter set point values to continue.
 - (14) Record the left PFD altitude and airspeed.
 - Expected results are 30,000 ± 40 feet, 200 ± 2.7 knots, and 0.557 ± 0.006 Mach.
 - (15) Set the Barfield Pitot/Static Tester DPS500 static pressure to 19,706 feet and increase airspeed to 237.6 knots as follows:
 - (a) Press ALT Ps to select the ALT control aim, enter 19706 and press Enter. Press SPEED Qc, enter 237.6 and press Enter. Wait for at least a 15 second stabilization period after the altitude and airspeed achieve these new air data parameter set point values to continue.
 - (16) Record the left PFD altitude and airspeed.
 - Expected results are 20,000± 40 feet, 240 ± 3 knots, and 0.535 ± 0.006 Mach.
 - (17) Set the Barfield Pitot/Static Tester DPS500 static pressure to 9,872 feet and set airspeed to 195.9 knots as follows:
 - (a) Press ALT Ps to select the ALT control aim, enter 9872 and press Enter. Press SPEED Qc, enter 195.9 and press Enter. Wait for at least a 15 second stabilization period after the altitude and airspeed achieve these new air data parameter set point values to continue.
 - (18) Record the left PFD altitude and airspeed.
 - Expected results are 10,000± 33 feet and 200 ± 2.7 knots.
 - (19) Set the Barfield Pitot/Static Tester DPS500 static pressure to 6,008 feet and set airspeed to 66.1 knots as follows:
 - (a) Press ALT Ps to select the ALT control aim, enter 6008 and press Enter. Press SPEED Qc, enter 66.1 and press Enter. Wait for at least a 15 second

stabilization period after the altitude and airspeed achieve these new air data parameter set point values to continue.

- (20) Record the left PFD altitude and airspeed.
 - Expected results are 6,000 ± 25 feet and 65 ± 2 knots.
- (21) Press GROUND to go to atmospheric pressure. Press F1 (Go to Ground).
 - (a) After the Barfield Pitot/Static Tester DPS500 displays shows SAFE AT GROUND prompt, press CLEAR/QUIT.
- (22) Select WOnW on the WOW test box.
- (23) Make sure that the Pitot and Static heat ECB's are collared.
- (24) If no further maintenance is required, remove all of the NAV Aids test equipment from the aircraft. Stow all air data equipment and the Barfield Pitot/Static Tester DPS500. Also, refer to [SUBTASK AMM-34-11-00-071-921-002](#).

9. **Standby Pitot/Static Probe Verification Test**

SUBTASK AMM-34-11-00-071-701-006

NOTE: If a Barfield Pitot/Static Tester DPS450 is used for this test complete paragraph A. If a Barfield Pitot/Static Tester DPS500 is used, go to paragraph B.

- A. Standby Pitot/Static Probe Verification Test with a Barfield Pitot/Static Tester DPS450:
 - (1) Connect the WOW Box to the aircraft and make sure that the ECBs are collared. Refer to [SUBTASK AMM-34-11-00-071-921-001](#).
 - (2) Set the WOW Box switches to WOnW.
 - (3) Power up the aircraft by setting the SYS BATT and START BATT switches to ON and the BUS TIE switch to AUTO.
 - (4) Select WOffW on the WOW test box.
 - (5) Set the transponder to STBY on the PFD.
 - (6) If required, set both the left and right SDU baro to 29.92 by press and HOLD the MENU button until the Baro reads 29.92 (or use ARROWS to adjust the Baro reading)..

NOTE: Right SDU is optional.

 - Make sure the baro setting matches on the left and right SDU.
 - (7) Set the static pressure to 39,889 feet and set the airspeed to 197.0 Knots.
 - (a) Press ALT Ps to select the ALT control aim, enter 39889 and press ENTER. Press SPEED Qc and enter 197.0 then press ENTER. Wait for at least a 15 second stabilization period after the altitude and airspeed achieve these new air data parameter set point values to continue.
 - (8) Record the Pitot/Static probe Altitude and Airspeed from the SDU.
 - Expected Results: 40,000 ± 105 feet and 190 ± 2.7 knots.
 - (9) Set the static pressure to 29,874 feet and set the airspeed to 247.1 Knots.

- (a) Press ALT Ps to select the ALT control aim, enter 29874 and press ENTER. Press SPEED Qc and enter 247.1 then press ENTER. Wait for at least a 15 second stabilization period after the altitude and airspeed achieve these new air data parameter set point values to continue.
 - (10) Record the Standby Pitot/Static probe altitude and airspeed from the SDU.
 - Expected Results: 30000 ± 75 feet and 240 ± 2.7 knots.
 - (11) Set the static pressure to 19,899 feet and increase airspeed to 247.5 Knots.
 - (a) Press ALT Ps to select the ALT control aim, enter 19899 and press ENTER. Press SPEED Qc and enter 247.5 then press ENTER. Wait for at least a 15 second stabilization period after the altitude and airspeed achieve these new air data parameter set point values to continue.
 - (12) Record the Standby Pitot/Static probe altitude and airspeed from the SDU.
 - Expected Results: 20,000 ± 50 feet and 245 ± 3 knots.
 - (13) Set the static pressure to 9,998 feet and set the airspeed to 99.9 Knots.
 - (a) Press ALT Ps to select the ALT control aim, enter 9998 and press ENTER. Press SPEED Qc and enter 99.9 then press ENTER. Wait for at least a 15 second stabilization period after the altitude and airspeed achieve these new air data parameter set point values to continue.
 - (14) Record the Standby Pitot/Static probe altitude and airspeed from the SDU.
 - Expected Results: 10,000 ± 33 feet and 100 ± 3 knots.
 - (15) Set the static pressure to 5,999 feet and set the airspeed to 64.9 Knots.
 - (a) Press ALT Ps to select the ALT control aim, enter 5999 and press ENTER. Press SPEED Qc and enter 64.9 then press ENTER. Wait for at least a 15 second stabilization period after the altitude and airspeed achieve these new air data parameter set point values to continue.
 - (16) Record the Standby Pitot/Static probe altitude and airspeed from the SDU.
 - Expected results are 6,000 ± 30 feet and 65 ± 4 knots.
 - (17) Press GROUND to go to atmospheric pressure. Press F1 to select Yes to confirm.
 - (a) If the Barfield Pitot/Static Tester DPS450 is not in CONTROL MODE, press LEAK MEASURE/CONTROL.
 - (b) After the Barfield Pitot/Static Tester DPS450 displays shows SAFE AT GROUND prompt, power off the Barfield Pitot/Static Tester DPS450.
 - (18) If no further maintenance is required, remove all of the Nav Aids test equipment from the aircraft. Stow all air data equipment and the Barfield Pitot/Static Tester DPS450. Also, refer to [SUBTASK AMM-34-11-00-071-921-002](#).
- B. Standby Pitot/Static Probe Verification Test with a Barfield Pitot/Static Tester DPS500:
- (1) Connect the WOW Box or AMC to the aircraft and make sure that the ECBs are collared. Refer to [SUBTASK AMM-34-11-00-071-921-001](#).
 - (2) Set the WOW Box switches to WOnW.

- (3) Power up the aircraft by setting the SYS BATT and START BATT switches to ON and the BUS TIE switch to AUTO.
- (4) Select WOffW on the WOW test box.
- (5) Set the transponder to STBY on the PFD.
- (6) If required, set both the left and right SDU baro to 29.92 by press and HOLD the MENU button until the Baro reads 29.92 (or use ARROWS to adjust the Baro reading)..
NOTE: Right SDU is optional.
 - Make sure the baro setting matches on the left and right SDU.
- (7) Set the static pressure to 39,889 feet and set the airspeed to 197.0 Knots.
 - (a) Press ALT Ps to select the ALT control aim, enter 39889 and press ENTER. Press SPEED Qc and enter 197.0 then press ENTER. Wait for at least a 15 second stabilization period after the altitude and airspeed achieve these new air data parameter set point values to continue.
- (8) Record the Standby Pitot/Static probe altitude and airspeed from the SDU.
 - Expected Results: 40,000 ± 105 feet and 190 ± 2.7 knots.
- (9) Set the static pressure to 29,874 feet and set the airspeed to 247.1 Knots.
 - (a) Press ALT Ps to select the ALT control aim, enter 29874 and press ENTER. Press SPEED Qc and enter 247.1 then press ENTER. Wait for at least a 15 second stabilization period after the altitude and airspeed achieve these new air data parameter set point values to continue.
- (10) Record the Standby Pitot/Static probe altitude and airspeed from the SDU.
 - Expected Results: 30,000 ± 75 feet and 240 ± 2.7 knots.
- (11) Set the static pressure to 19,899 feet and increase airspeed to 247.5 Knots.
 - (a) Press ALT Ps to select the ALT control aim, enter 19899 and press ENTER. Press SPEED Qc and enter 247.5 then press ENTER. Wait for at least a 15 second stabilization period after the altitude and airspeed achieve these new air data parameter set point values to continue.
- (12) Record the Standby Pitot/Static probe altitude and airspeed from the SDU.
 - Expected Results: 20,000 ± 50 feet and 245 ± 3 knots.
- (13) Set the static pressure to 9,998 feet and set the airspeed to 99.9 Knots.
 - (a) Press ALT Ps to select the ALT control aim, enter 9998 and press ENTER. Press SPEED Qc and enter 99.9 then press ENTER. Wait for at least a 15 second stabilization period after the altitude and airspeed achieve these new air data parameter set point values to continue.
- (14) Record the Standby Pitot/Static probe altitude and airspeed from the SDU.
 - Expected Results: 10,000 ± 33 feet and 100 ± 3 knots.
- (15) Set the static pressure to 5,999 feet and set the airspeed to 64.9 Knots.

- (a) Press ALT Ps to select the ALT control aim, enter 5999 and press ENTER. Press SPEED Qc and enter 64.9 then press ENTER. Wait for at least a 15 second stabilization period after the altitude and airspeed achieve these new air data parameter set point values to continue.
- (16) Record the Standby Pitot/Static probe altitude and airspeed from the SDU.
 - Expected Results: 6000 ± 30 feet and 65 ± 4 knots.
- (17) Press GROUND to go to atmospheric pressure. Press F1 to select Yes to confirm.
 - (a) If the Barfield Pitot/Static Tester DPS500 is not in CONTROL MODE, press LEAK MEASURE/CONTROL.
 - (b) After the Barfield Pitot/Static Tester DPS500 displays shows SAFE AT GROUND prompt, power off the Barfield Pitot/Static Tester DPS500.
- (18) If no further maintenance is required, remove all of the Nav Aids test equipment from the aircraft. Stow all air data equipment and the Barfield Pitot/Static Tester DPS500. Also, refer to [SUBTASK AMM-34-11-00-071-921-002](#).

10. Outside Air Temperature Test

SUBTASK AMM-34-11-00-071-701-007

A. Do an Outside Air Temperature Test as follows:

- (1) Power up the aircraft by setting the SYS BATT and START BATT switches to ON and the BUS TIE switch to AUTO.
- (2) Scroll to the ICE synoptic page on the MFD by using the lower left/right softkey.
- (3) Expected results are that left and right OATs are within ± 5° C of the measured outside temperature. Left and Right PFDs are within ± 2° C of MFD OAT temperature.
- (4) Power down the aircraft by setting the SYS BATT and START BATT switches to OFF and the BUS TIE switch to OPEN.

11. Job Close-Up

SUBTASK AMM-34-11-00-071-921-002

A. If no other tests are required with the Weight On Wheels (WOW) box, select WOnW.

- (1) Re-set the following ECBs:
 - ECB - WEATHER RADAR (L FWD Bus)
 - ECB - DEICE MANIFOLD HTR (R AFT Bus)
 - ECB - L PITOT HEAT (L FWD Bus) or ECB - L PITOT HEAT (BATT Bus)
 - ECB - R PITOT HEAT (R FWD Bus)
 - ECB - L STATIC HEAT (BATT Bus)
 - ECB - L STATIC HEAT (R FWD Bus)
 - ECB - R STATIC HEAT (R FWD Bus)

-
- ECB - R STATIC HEAT (L FWD Bus)
 - ECB - STBY PITOT HEAT (BATT Bus) or ECB - STBY PITOT HEAT (L FWD)
 - ECB - L WINDSHIELD HEAT (L AFT Bus)
 - ECB - R WINDSHIELD HEAT (R AFT Bus)
- (2) Power down the aircraft by setting the SYS BATT and START BATT switches to OFF and the BUS TIE switch to OPEN.
- (3) Disconnect WOW Box from aircraft. Refer to AMM-20-00-04-051-801 – Weight On Wheels (WOW) Box - Connect/Disconnect.
- B. Remove the external power from the aircraft. Refer to [AMM-24-40-00-051-801 – External Power - Maintenance Practices](#).
- C. Remove all tools, equipment and unwanted material from work area.
- D. If all other maintenance is complete, return aircraft to service. Refer to [AMM-20-00-02-051-801 – Return To Service \(After Maintenance\)](#).

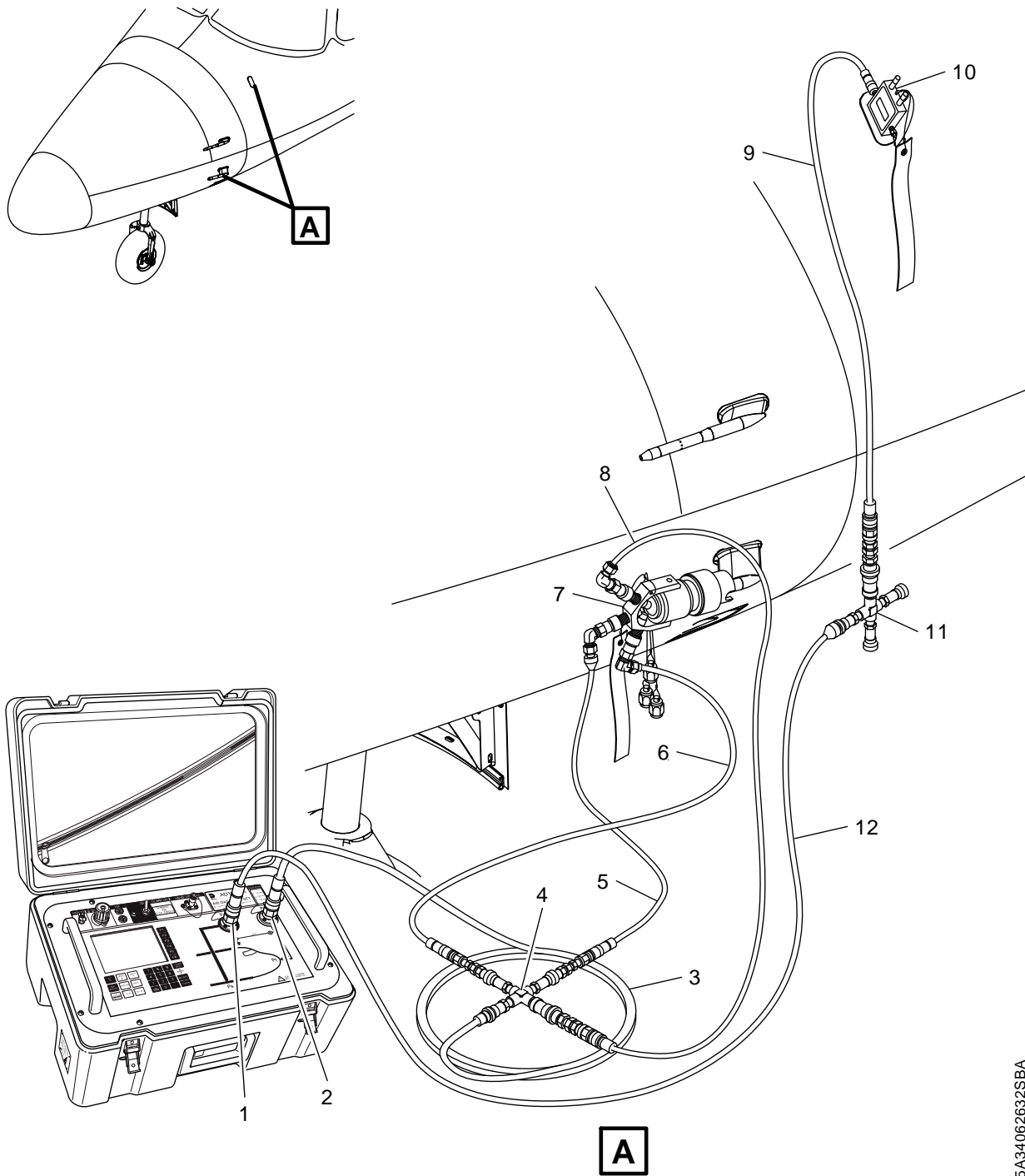

5A34062632SBA

Left Pitot/Static Hose Configuration (Three Port Adapter)
Figure 501 (Sheet 1 of 1)

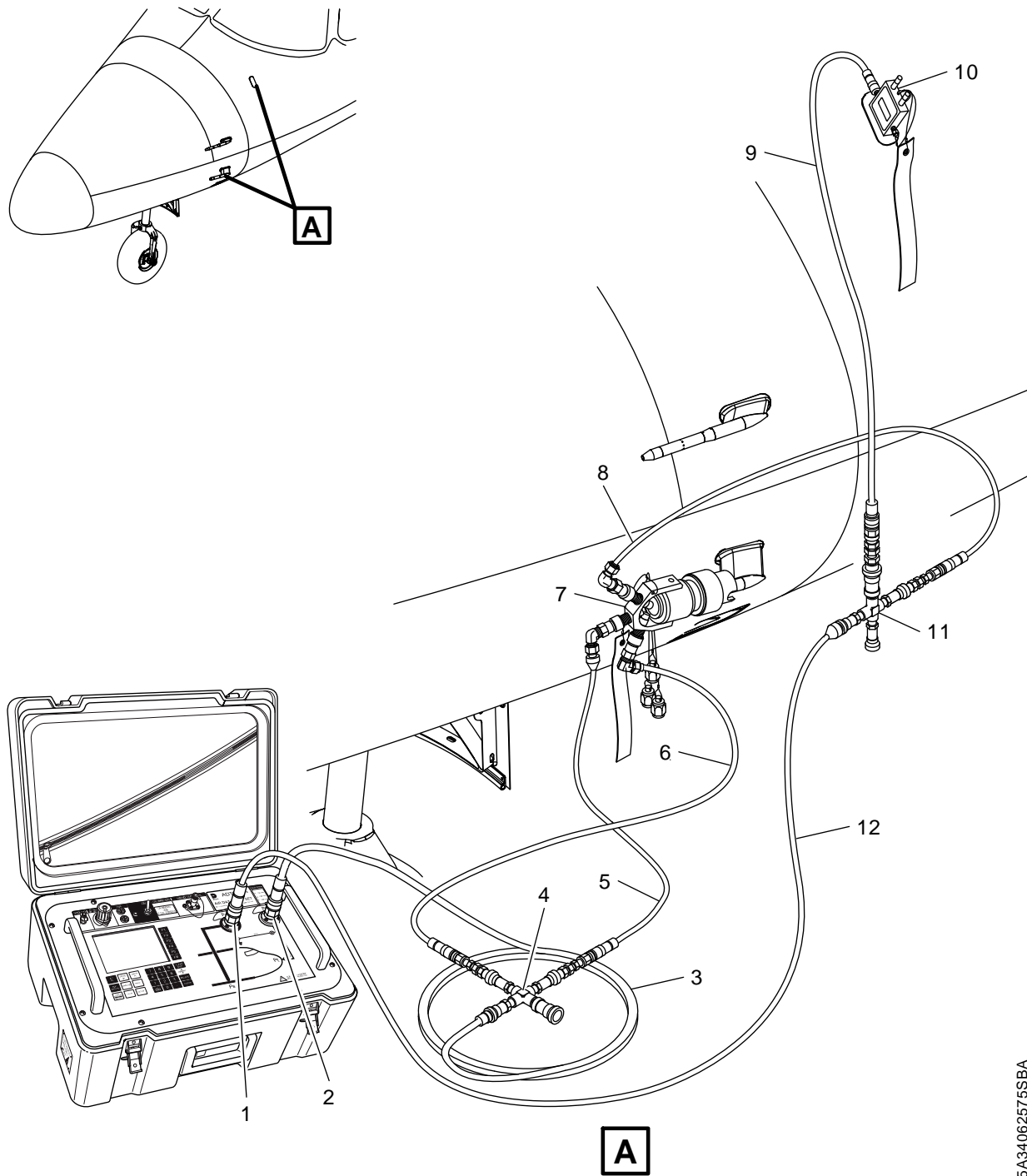

5A34062575SBA

**Left Angle of Attack Hose Configuration
Figure 502 (Sheet 1 of 1)**

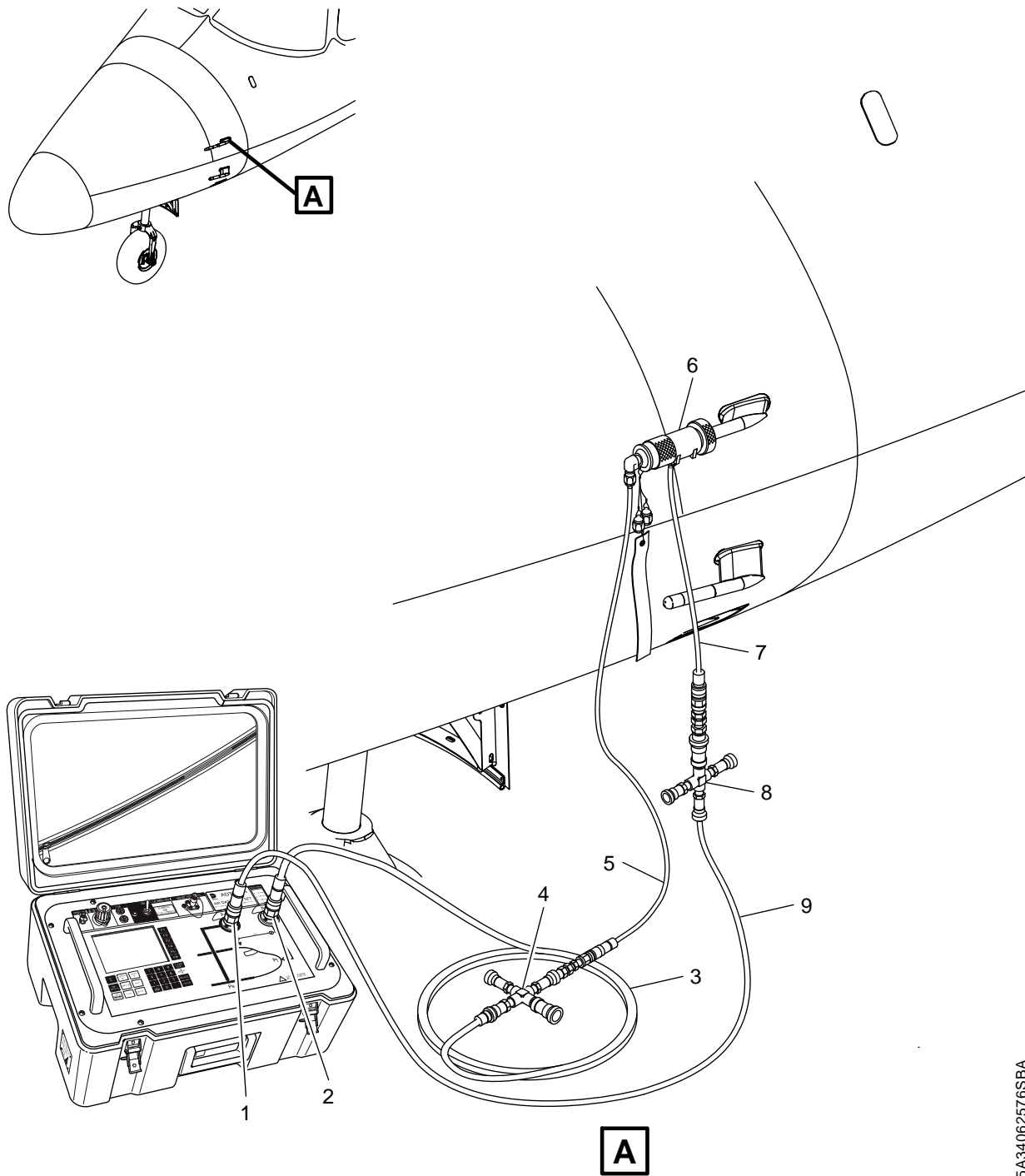

5A34062576SBA

Standby Pitot/Static Test Adaptor Connections
Figure 503 (Sheet 1 of 1)

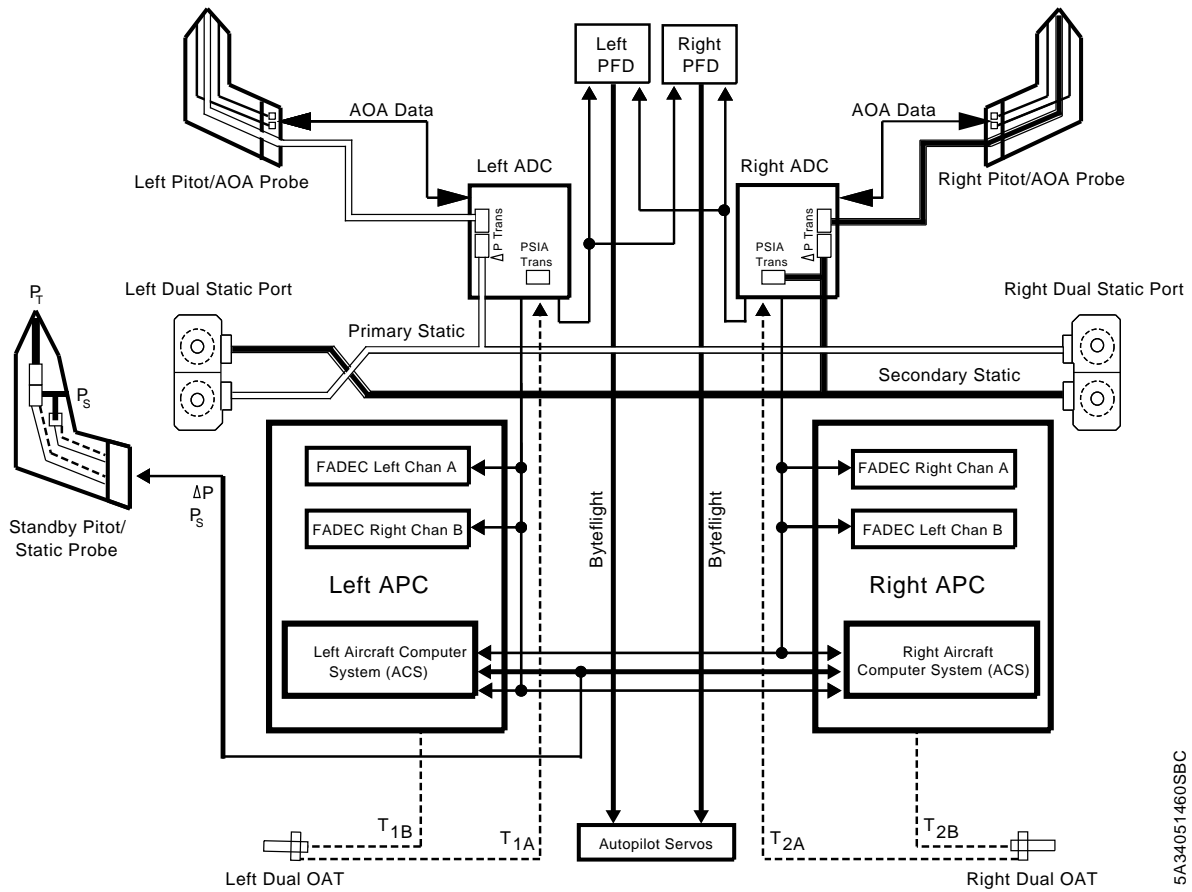

5A34051460SEC

**Air Data System Block Diagram
Figure 504 (Sheet 1 of 1)**

THIS PAGE INTENTIONALLY LEFT BLANK

PITOT/AOA PROBES - REMOVAL

AMM-34-11-10-001-C-801

1. General

- A. This task gives the procedures to remove the Pitot/Angle of Attack (AOA) probes.
- B. There are two Pitot/AOA probes on the fuselage, forward of the cockpit. Access procedures for the right Pitot/AOA probe are given in Job Setup.

NOTE: In the event the grounding jumper needs to be replaced, the entire probe must be removed.

NOTE: In the event that the auxiliary heater needs to be replaced, the entire probe must be removed.

2. Job Set-Up

SUBTASK AMM-34-11-10-001-C-921-001

- A. Make aircraft safe for maintenance. Refer to [AMM-20-00-01-051-801 – Make Safe For Maintenance](#).
- B. To gain access to remove the left Pitot/AOA probe remove the access panel that follows:
 - 211 CT - Nose Access Panel
- C. To gain access to remove the right Pitot/AOA, use the Air Conditioning controls to open the VCS doors, as follows:
 - (1) Connect AMC to right armrest USB port. Refer to [Fig. 402](#).
 - (2) On the MFD ENVIR page, establish the following conditions:
 - AIR COND: AUTO
 - AFT Fan: AUTO
 - FWD Fan: AUTO
 - Cockpit Temp: MAX COOL
 - Cabin Temp: MAX COOL
 - (3) Make sure the Forward and Aft VCS doors have fully opened. Refer to [AMM-21-00-00-071-801 – Air Conditioning - Adjustment/Test](#), . Refer to [Fig. 403](#).
- D. Remove power from the aircraft.

CAUTION: AFT VCS DOOR MUST BE DISABLED TO PREVENT PERSONAL INJURY AND DAMAGE TO EQUIPMENT IF AIRCRAFT POWER IS INADVERTENTLY APPLIED.

- (1) Once electrical power is removed, disconnect the electrical connector on the aft VCS door actuator.

3. Procedure

SUBTASK AMM-34-11-10-001-C-011-001

(Refer to [Fig. 401](#).)

- A. Disconnect electrical connector (17) from aircraft wiring harness.
 - B. Remove jam nut (15) from electrical connector (17) and remove electrical connector from bracket (16) by removing .
 - C. Disconnect electrical connector (2) from Pitot/AOA probe (4) .
 - D. Disconnect Pitot tube assembly (3) from Pitot/AOA probe (4) .
 - E. Disconnect Pitot/AOA Auxiliary Heater electrical connector (17) from aircraft harness.
 - F. Remove jam nut (15) from Pitot/AOA Auxiliary Heater electrical connector (17) and remove connector (17) from bracket (16) .
 - G. For the LH Pitot/AOA probe ([Fig. 401, Sheet 2](#)), remove the self locking nut (8) , lock washer (9) , flat washer (10) , grounding jumper (7) , and the hex head screw (11) from hole (12) in the aircraft structure.
 - H. For the RH Pitot/AOA probe ([Fig. 401, Sheet 3](#)), remove the self locking nut (8) , flat washer (10) , grounding jumper (7) , and the hex head screw (11) from hole (12) in the aircraft structure.
 - I. Remove five screws (5) that attach Pitot/AOA probe (4) to structure (1) .
 - J. Remove Pitot/AOA probe (4) with grounding jumper (7) attached and gasket (6) from aircraft.
- NOTE:** Do not remove grounding jumper from probe unless it needs to be replaced.
- K. If required for the LH Pitot/AOA probe ([Fig. 401, Sheet 2](#)), remove the screw (14) , washer (13) , and grounding jumper (7) from the Pitot/AOA probe (4) .
 - L. If required for the RH Pitot/AOA probe ([Fig. 401, Sheet 3](#)), remove the screw (14) , washer (13) , and grounding jumper (7) from the Pitot/AOA probe (4) .

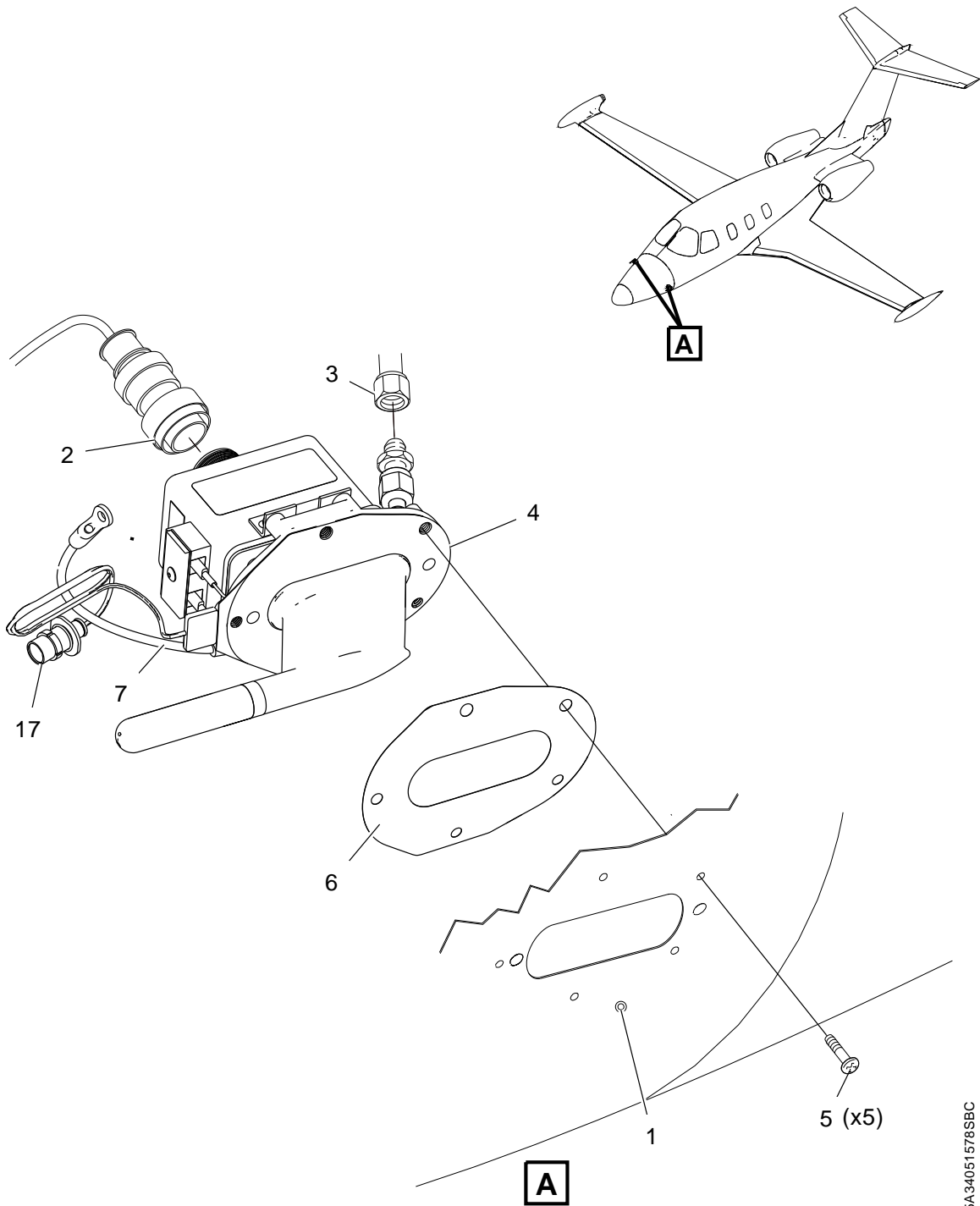

5A 34051578SBC

Pitot/AOA Probes - Removal/Installation
Figure 401 (Sheet 1 of 4)

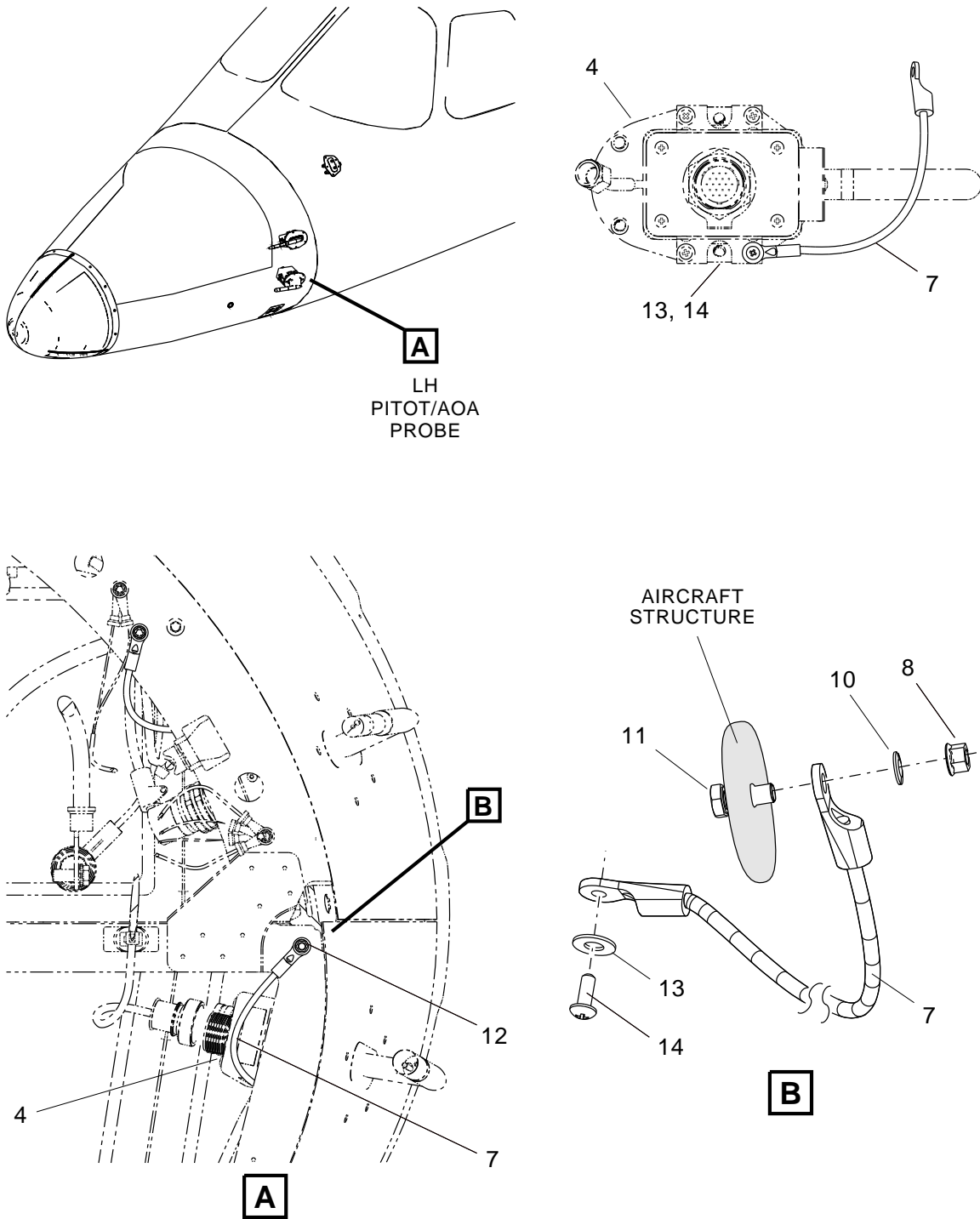

5141820A

Pitot/AOA Probes - Removal/Installation
Figure 401 (Sheet 2 of 4)

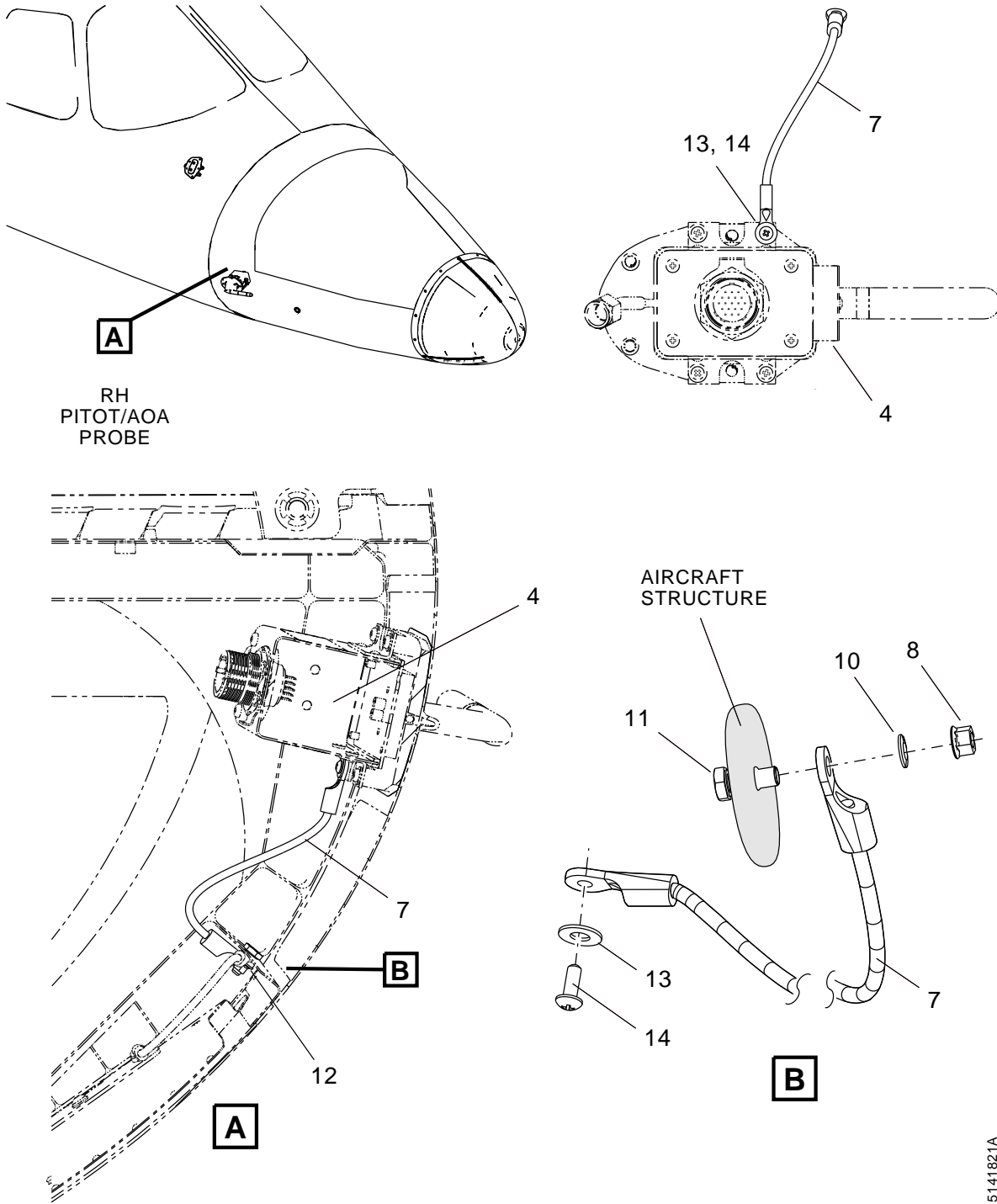

Pitot/AOA Probes - Removal/Installation
Figure 401 (Sheet 3 of 4)

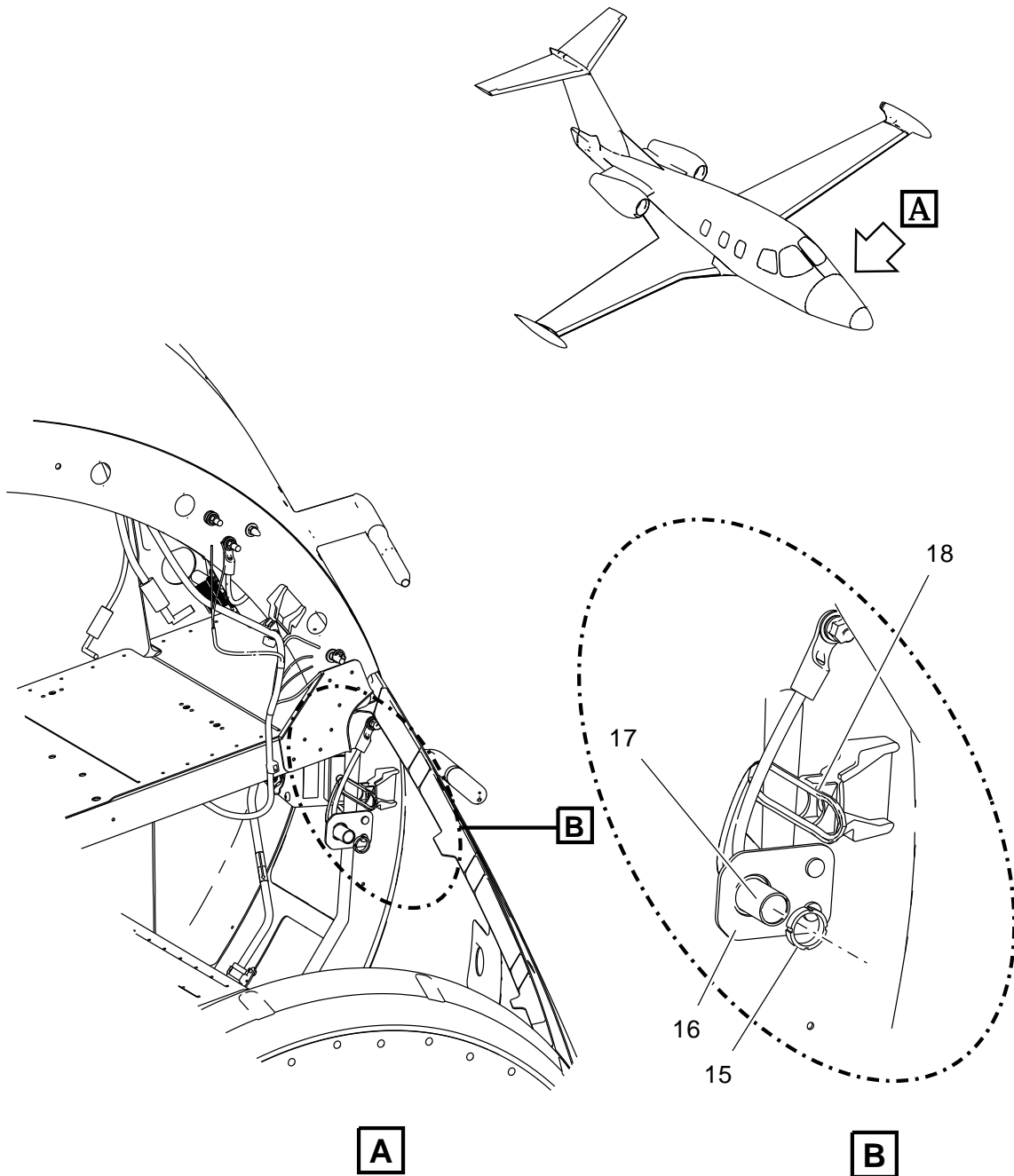

5171943A

Pitot/AOA Probes - Removal/Installation
Figure 401 (Sheet 4 of 4)

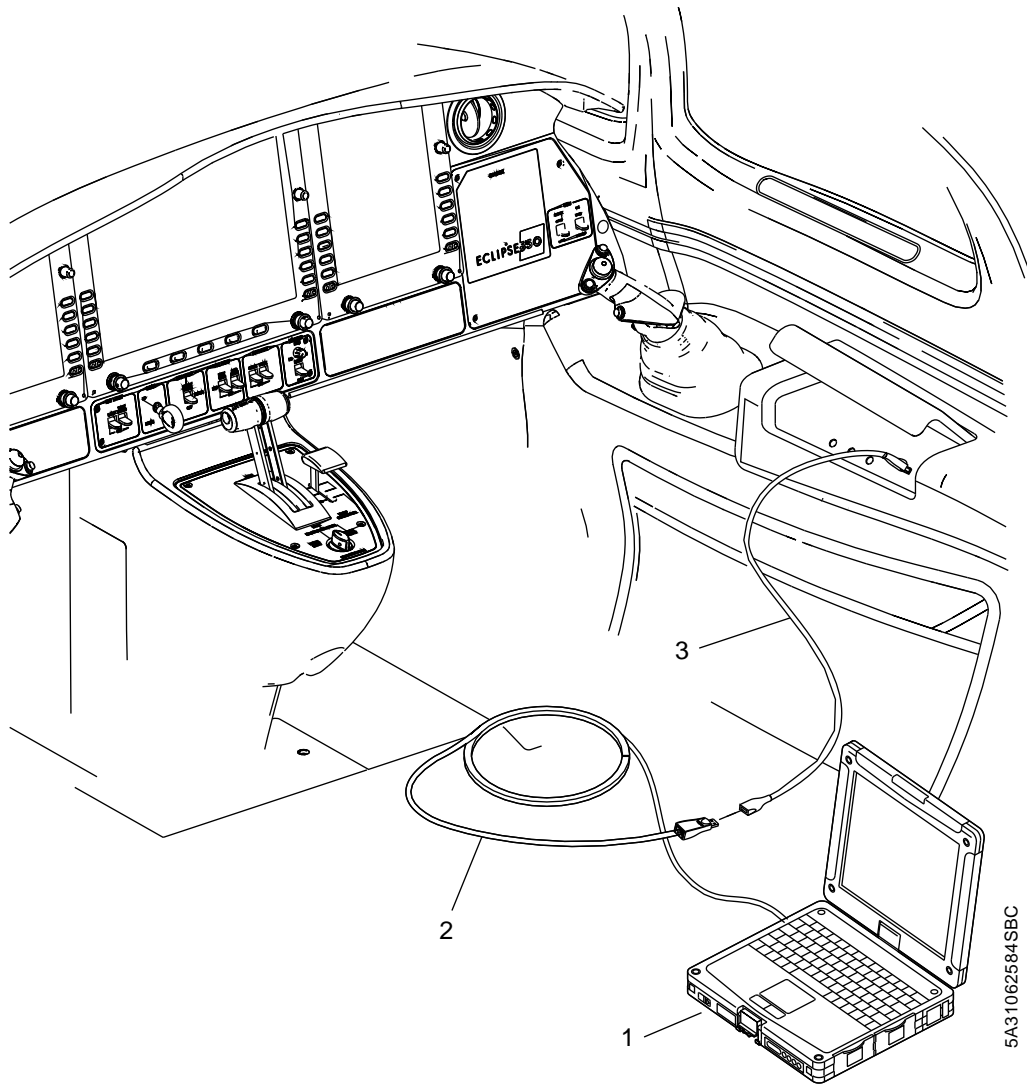

5A31062584 SBC

Co-pilot's Armrest USB Port - AMC Hookup
Figure 402 (Sheet 1 of 1)

AVIO MAINTENANCE COMPUTER

| | | | | | | |
|-----------|-------------|--------------|-------------|---------------|--------------|-------------|
| 52 Doors | 72 Engine | 73 Fuel Ctrl | 74 Ignition | 75 Engine Air | 76 Eng Ctrl | 80 Starting |
| 30 De-Ice | 31 Instr | 32 Ldg Gear | 33 Lights | 34 Nav/Pitot | 35 Oxygen | 36 Pneum |
| 8 Weigh | 21 Air Cond | 22 Autopilot | 24 Elec Pwr | 26 Fire | 27 Flt Ctrls | 28 Fuel |

VCS Door Cals

Start Done

Closed Fwd VCS Inlet 9.48 Open

10 9 8 7 6 5 4 3 2 1 0

9.49 Default << < > >> Default 3.17

Closed Aft VCS Outlet 1.49 Open

0 1 2 3 4 5 6 7 8 9 10

1.46 Default << < > >> Default 8.69

EA500.XXXX DSU App L-ACS R-ACS 5080708B

VCS Door Cals Page
Figure 403 (Sheet 1 of 1)

PITOT/AOA PROBE - INSTALLATION

AMM-34-10-10-041-C-801

1. General

- A. This task gives the procedures to install the Pitot/Angle of Attack (AOA) probes.

2. Job Set-Up

SUBTASK AMM-34-10-10-041-C-921-001

(Refer to [Fig. 401, Sheet 1.](#))

- A. Make sure aircraft is in the same configuration as it was when the removal task was completed. Refer to [AMM-34-10-10-001-C-801 – Pitot/AOA Probes - Removal.](#)
- B. If the Pitot/AOA probe is new, check to see if a packing (support) block (1) is supplied with the unit.

NOTE: New assemblies may be shipped from the manufacturer with a packing block (1) in order to protect the device during shipping, handling and installation.

- (1) It is strongly recommended that new Pitot/AOA probe(s) should be mounted to the aircraft with the packing block (1) still in place in order to prevent pinching and kinking of the main plumbing line (2) and connection (3) during the installation process. It is also recommended that a Pitot cover be used on the Pitot/AOA probe as practical during and after installation in order to provide increased protection against foreign object damage (FOD).

3. Procedure

SUBTASK AMM-34-10-10-041-C-411-001

(Refer to [Fig. 401.](#))

CAUTION: REMOVE THE NOTED SCREW FROM THE PITOT/AOA PROBE ONLY.
DO NOT LOOSEN OR DISTURB OTHER MOUNTING HARDWARE.

NOTE: The fastener securing the grounding jumper to the probe shall be installed using torque required to bring the bearing faces into positive contact and have Loctite 242 to applied to the screw threads.

- A. If required for the LH Pitot/AOA probe ([Fig. 401, Sheet 3](#)), install the grounding jumper (7) to the probe (4) using the existing washer (14) and screw (13) from the previously installed grounding jumper.
- B. If required for the RH Pitot/AOA probe ([Fig. 401, Sheet 4](#)), install the grounding jumper (7) to the Pitot/AOA probe (4) using the existing washer (14) and screw (13) from the previously installed grounding jumper.
- C. Install Pitot/AOA probe (4) and gasket (6) in structure (1) and align holes.
- D. Attach Pitot/AOA probe (4) to structure (1) with five screws (5).

- E. For the LH Pitot/AOA probe (Fig. 401, Sheet 3), install the grounding jumper (7) to the aircraft structure by placing hex head screw (11) through hole (12) and securing the grounding jumper with flat washer (10), lock washer (9), and self locking nut (8).
- F. For the RH Pitot/AOA probe (Fig. 401, Sheet 4), install the grounding jumper (7) to the aircraft structure by placing hex head screw (11) through hole (12) and securing the grounding jumper with flat washer (10), and self locking nut (8).
- G. Do electrical bonding of Pitot/AOA probe (4) to structure (1). Refer to [AMM-20-03-00-051-801 – Electrical Bonding - Maintenance Practices](#). Resistance must be 2.5 milliohms or less.
- H. Do electrical bonding of aft VCS door (12) per instructions in [AMM-21-10-15-041-801 – Aft VCS Door Actuator - Installation](#).
- I. Connect electrical connector (2) to Pitot/AOA probe (4).
- J. Install Auxiliary Heater electrical connector (17) to bracket (16).
- K. Secure electrical connector (17) with jam nut (15). Torque to 35-45 lbf.in (4.0-5.1 Nm)
- L. Connect Pitot/AOA Auxiliary Heater electrical connector (17) to aircraft harness.

CAUTION: DO NOT USE EXCESSIVE TORQUE. TOO MUCH TORQUE CAN DAMAGE AND DEFORM PLUMBING LINES, STRUCTURE, AND FASTENERS.

- M. Connect Pitot tube assembly (3) to Pitot/AOA probe (4). Torque to 20-30 lbf.in (2.3-3.4 Nm).
- N. Use PRC-Desoto aerodynamic smoothing sealant (PR-2050) to close gaps and seal around Pitot/AOA probes. [AMM-20-08-00-051-801 – Sealants and Adhesives - Maintenance Practices](#).

4. **Job Close-Up**

SUBTASK AMM-34-10-10-041-C-921-002

CAUTION: MAKE SURE ANY PACKING/MATERIALS SUPPLIED WITH THE UNIT ARE REMOVED AND NOT LEFT IN PLACE BETWEEN THE PROBE BODY AND THE AIRCRAFT AFTER INSTALLATION.

- A. If applicable, discard packing block after installation.
- B. Do an inspection/check of the (applicable) Pitot/AOA probe following installation. Refer to [AMM-34-10-00-021-801 – Flight Environment Data - Inspection/Check](#).
- C. Reconnect the electrical connectors on the aft VCS door actuator if removed.
- D. Apply power to the aircraft.
 - (1) Connect AMC to right armrest USB port. Refer to [Fig. 402](#).
 - (2) Make sure that the Forward and Aft VCS doors have fully closed if opened. Refer to [AMM-21-00-00-071-801 – Air Conditioning - Adjustment/Test](#), . Refer to [Fig. 403](#).

-
- E. Do adjustment/test of the Pitot/AOA probe(s) following installation. Refer to [AMM-34-10-00-071-801 – Flight Environment Data - Adjustment/Test](#).

CAUTION: DURING THIS TEST, THE HEATERS WILL BE COMMANDED ON BY THE SYSTEM. RH AND LH PITOT/AOA PROBES WILL HEAT UP TO APPROXIMATELY 500°C. HARM TO PERSONNEL OR EQUIPMENT CAN OCCUR IF TOUCHING THE PROBES. DO NOT LEAVE ON FOR EXTENDED TIME. ALLOW 10 MINUTES AFTER TEST FOR PROBES TO COOL.

- F. Do adjustment/test of the Pitot/AOA probe heat. Refer to [AMM-30-30-00-071-C-801 – Pitot and Static Anti-Ice System - Adjustment/Test](#).
- G. Install access panel that follows as necessary:
- Install 211 CT - Nose Access Panel. Refer to [AMM-06-50-00-051-801 – Aircraft Access Panels](#).
- H. Remove power from the aircraft.
- I. Remove all tools, equipment and unwanted material from work area.
- J. If all other maintenance is complete, return aircraft to service. Refer to [AMM-20-00-02-051-801 – Return To Service \(After Maintenance\)](#).

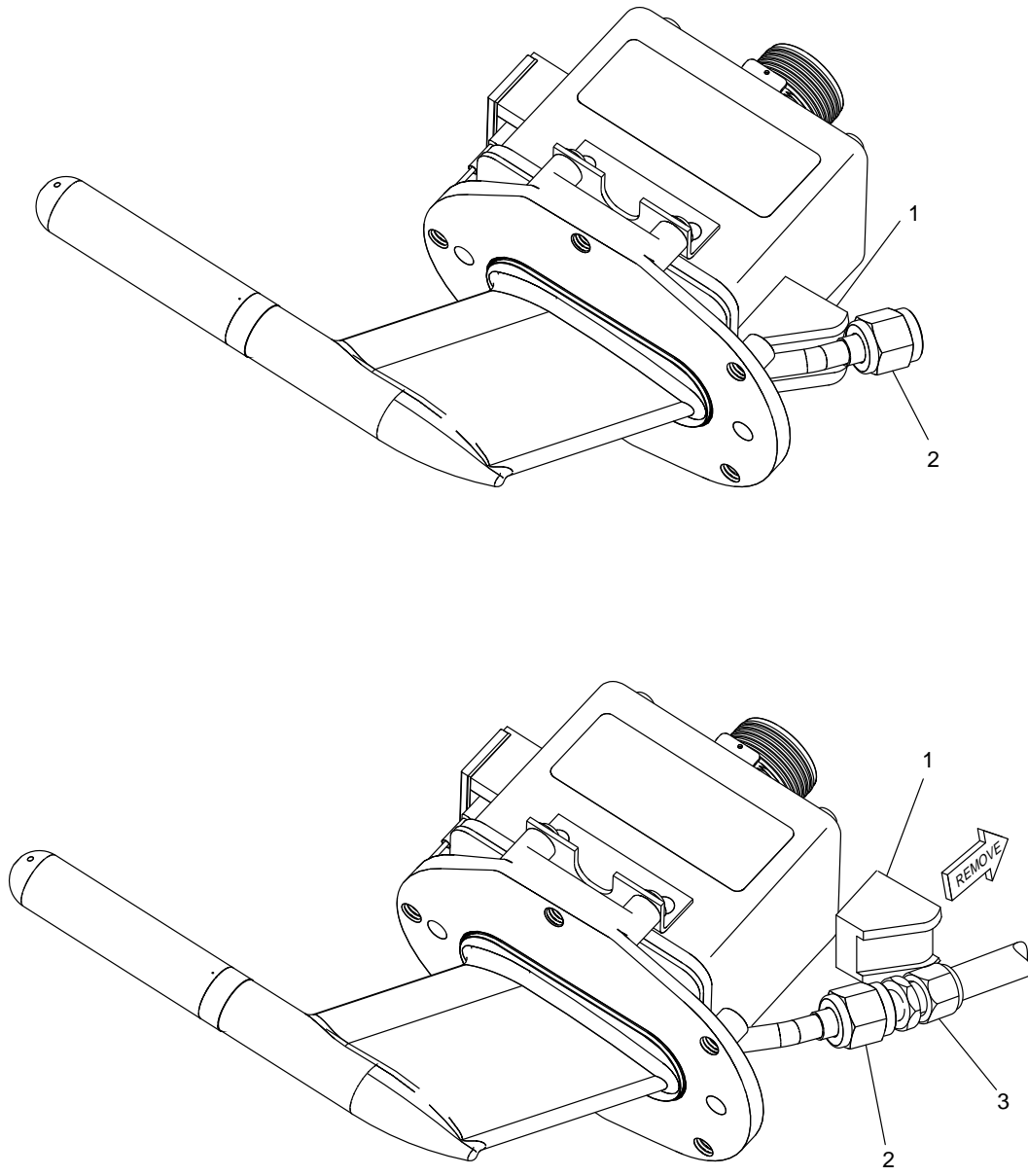

Pitot/AOA Probes - Removal/Installation
Figure 401 (Sheet 1 of 5)

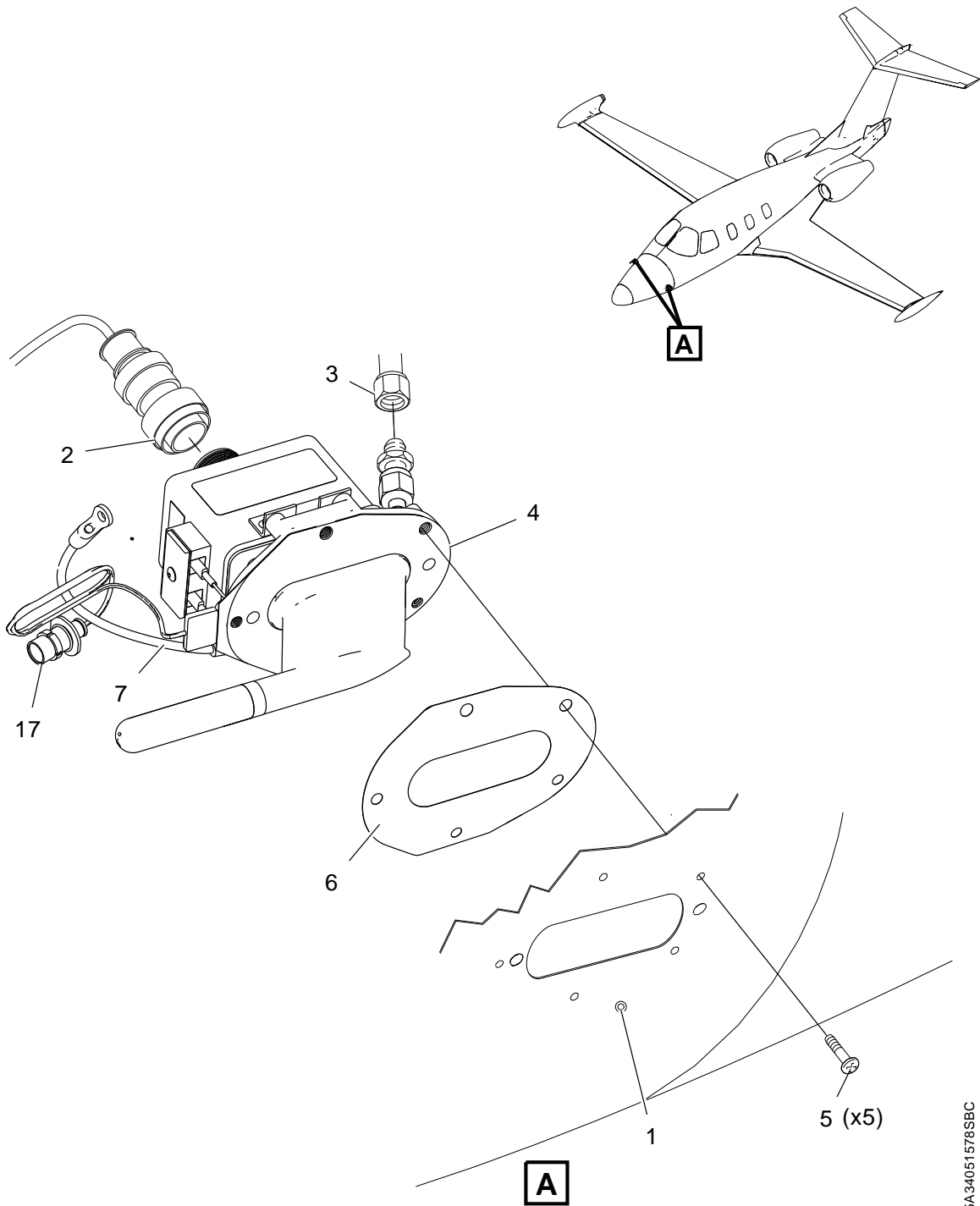

5A 34051578SBC

Pitot/AOA Probes - Removal/Installation
Figure 401 (Sheet 2 of 5)

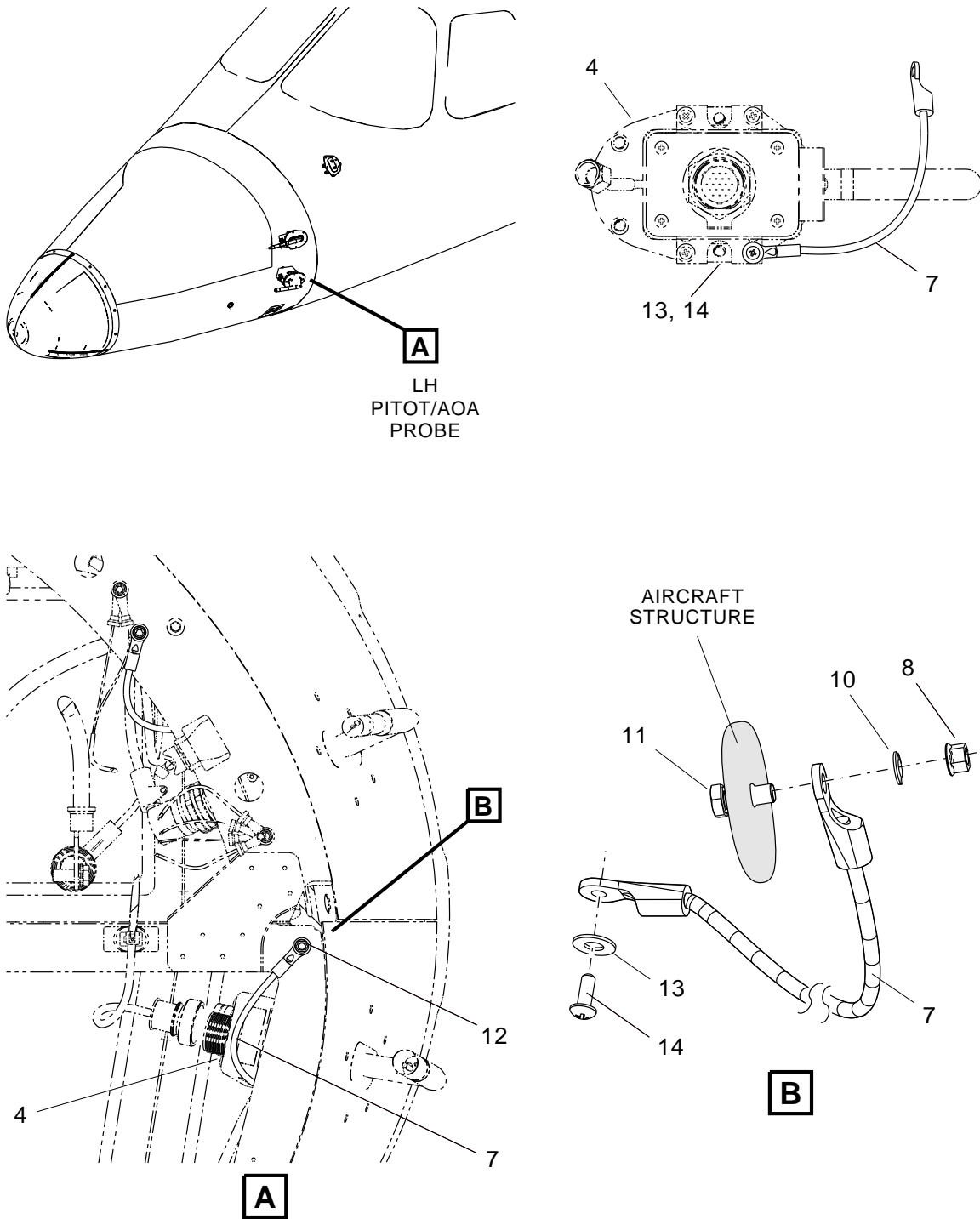

5141820A

Pitot/AOA Probes - Removal/Installation
Figure 401 (Sheet 3 of 5)

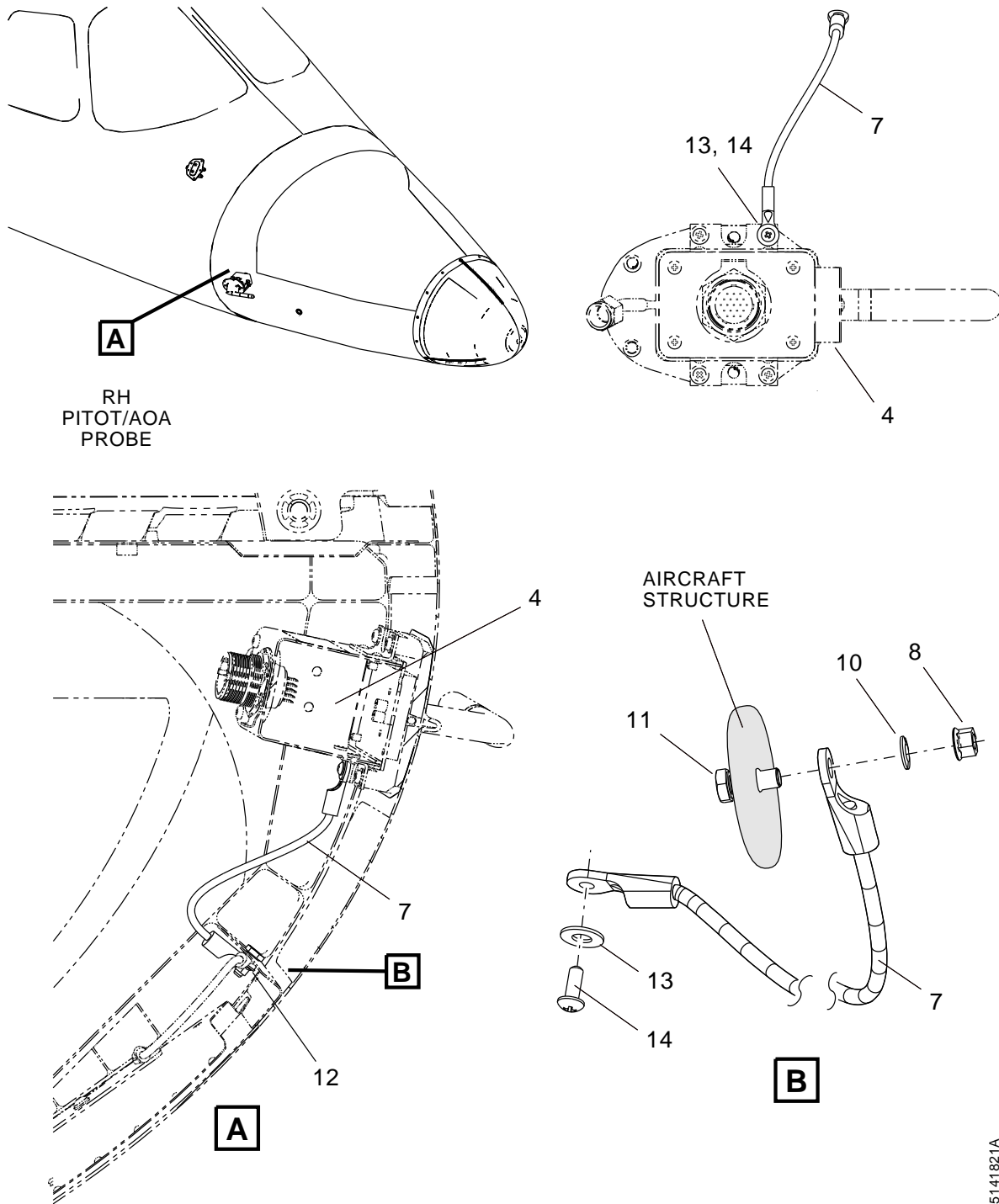

Pitot/AOA Probes - Removal/Installation
Figure 401 (Sheet 4 of 5)

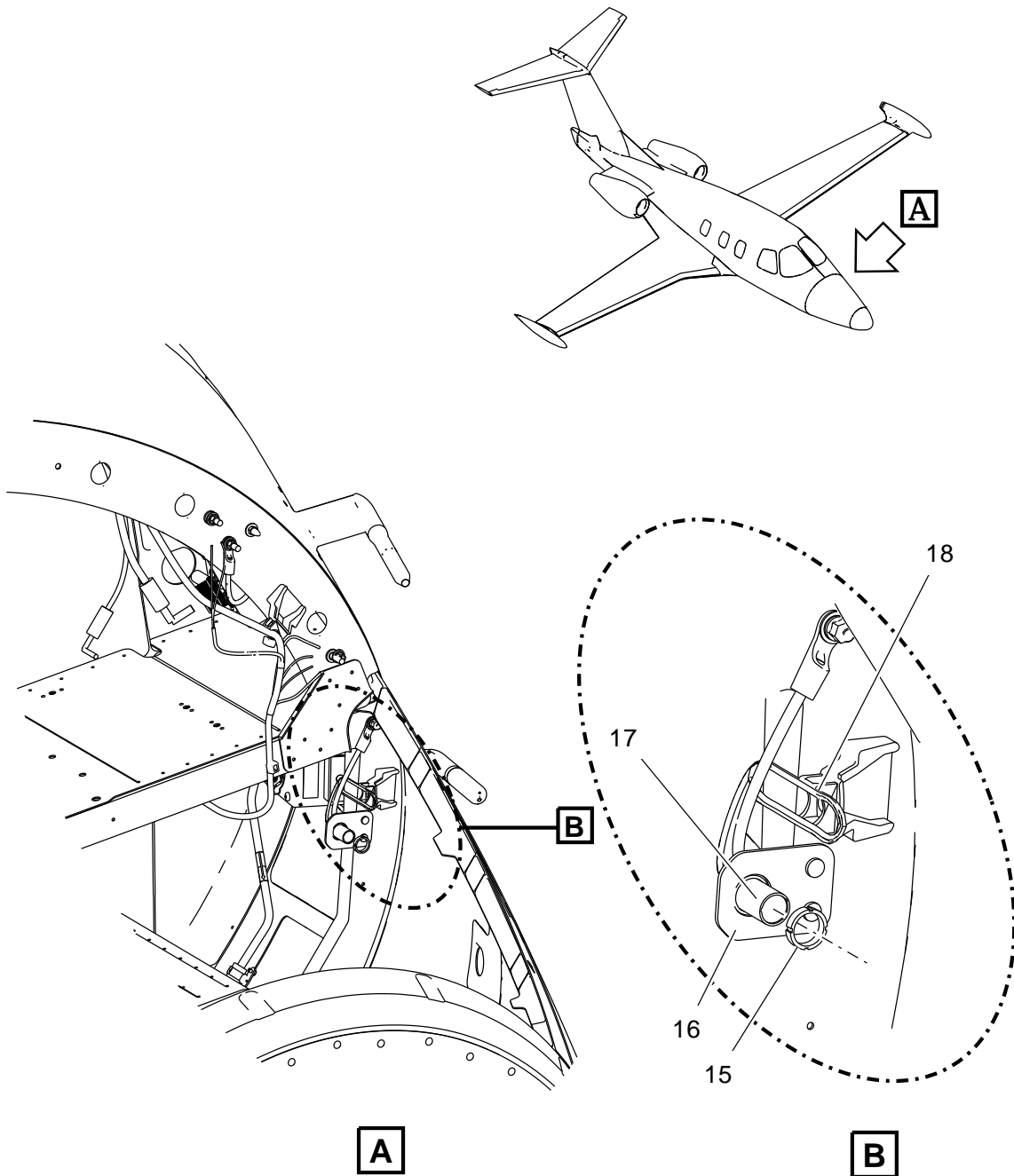

5171943A

Pitot/AOA Probes - Removal/Installation
Figure 401 (Sheet 5 of 5)

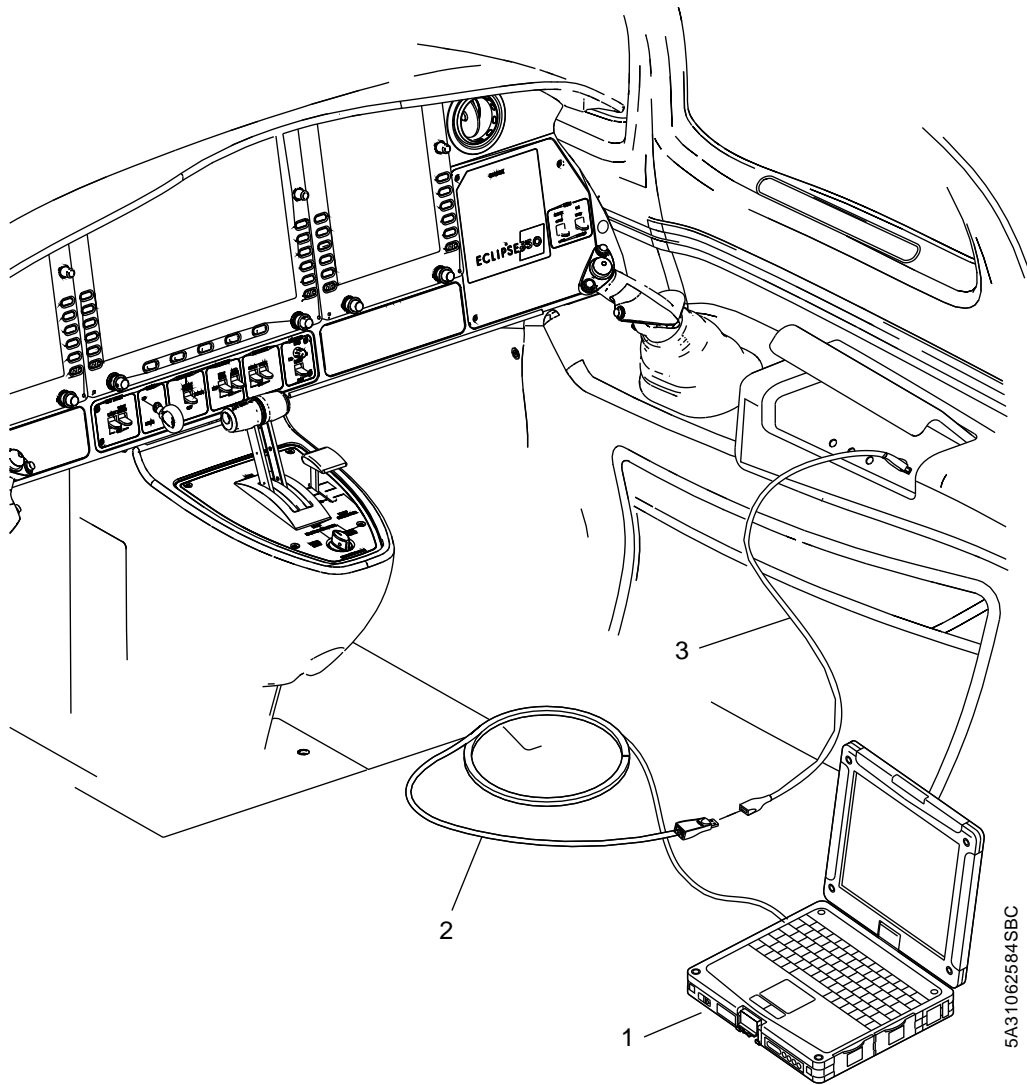

5A31062584 SBC

Co-pilot's Armrest USB Port - AMC Hookup
Figure 402 (Sheet 1 of 1)

AVIO MAINTENANCE COMPUTER

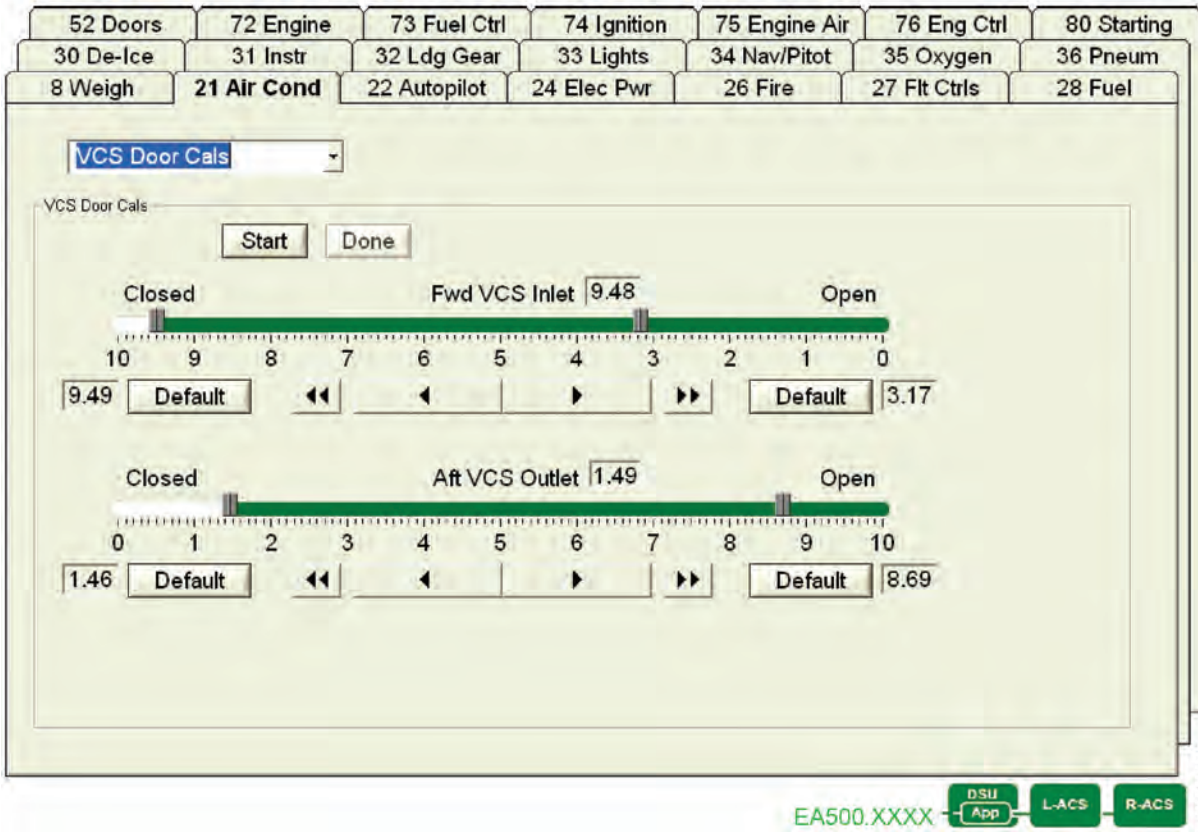

VCS Door Cals Page
Figure 403 (Sheet 1 of 1)

GPS - REMOVAL

AMM-34-50-11-001-801

1. General

- A. This task gives the procedure to remove the Global Positioning System/Wide Area Augmentation System (GPS/WAAS) sensors.
- B. There are two GPS/WAAS sensors installed in the aircraft. Removal steps are the same for the light and right sides, unless specified.

2. Job Set-Up

SUBTASK AMM-34-50-11-001-921-001

- A. Make the aircraft safe for maintenance. Refer to [AMM-20-00-01-051-801 – Make Safe For Maintenance..](#)
- B. Remove power from the aircraft. Refer to [AMM-24-40-00-051-801 – External Power - Maintenance Practices..](#)
- C. Remove the 231 JZ – Cabin Headliner Assembly. Refer to [AMM-06-50-00-051-801 – Aircraft Access Panels.](#)

3. Procedure

SUBTASK AMM-34-50-11-001-011-001

(Refer to [Fig. 401.](#))

- A. Remove the four bolts (1) that attach the GPS/WAAS sensor (4) to the mounting bracket (5).
 - (1) For the right side sensor, remove the four spacers (6) .
- B. Disconnect the electrical connector (2) and Coax Threaded Neill-Concelman (TNC) connector (3) from the GPS/WAAS sensor (4) .
- C. Remove the GPS/WAAS sensor (4) from the mounting bracket (5) .
- D. Install protective caps on the electrical connector (2) and Coax TNC connector (3) .

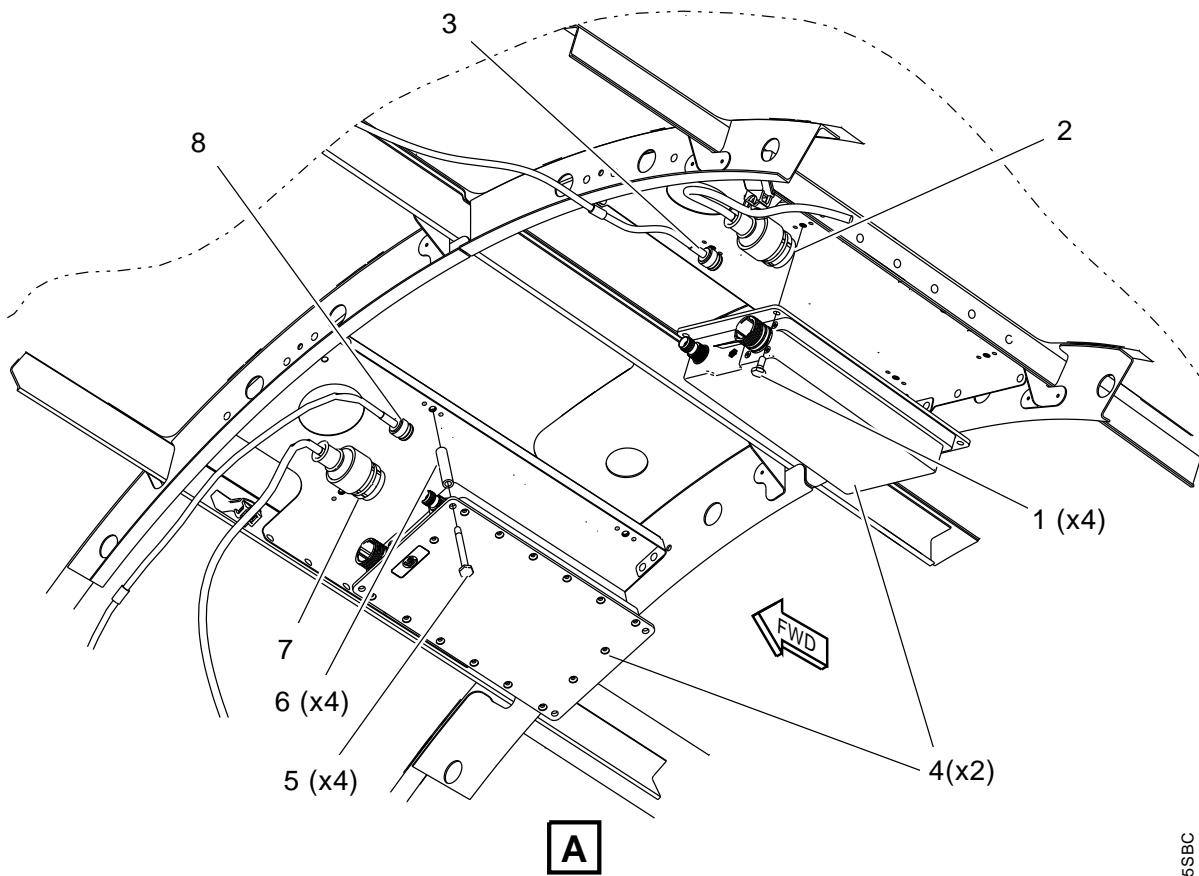
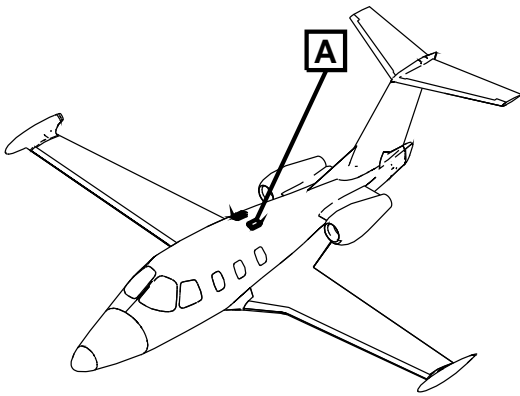

(ROTATED FOR CLARITY)

5A34051335SBC

GPS - Removal/Installation
Figure 401 (Sheet 1 of 1)

GPS - INSTALLATION

AMM-34-50-11-041-801

1. General

- A. This task gives the procedure to install the Global Positioning System/Wide Area Augmentation System (GPS/WAAS) sensors.
- B. There are two GPS/WAAS sensors installed in the aircraft. Installation steps are the same for the left and right sides, unless specified.

2. Job Set-Up

SUBTASK AMM-34-50-11-041-921-001

- A. Make sure the aircraft is in the same configuration it was when the removal task was completed. Refer to [AMM-34-50-11-001-801 – GPS - Removal](#).

3. Procedure

SUBTASK AMM-34-50-11-041-411-001

(Refer to [Fig. 401](#).)

- A. Put the GPS/WAAS sensor (4) on the mounting bracket (5) and align the bolt holes.
 - (1) Make sure the electrical connectors are facing forward.
 - (2) For the left side sensor, make sure the GPS/WAAS sensor (4) mounting flange is toward the outboard side of the aircraft and against the mounting bracket (5).
 - (3) For the right side sensor, make sure the GPS/WAAS sensor (4) mounting flange is toward the inboard side on the aircraft and away from the mounting bracket (5).
- B. Attach the GPS/WAAS sensor (4) to the mounting bracket (5).
 - (1) For the left side GPS/WAAS sensor (4), attach the sensor (4) to the mounting bracket (5) with the four bolts (1).
 - (2) For the right side GPS/WAAS sensor (4), attach the sensor (4) to the mounting bracket (5) with the four bolts (1) and spacers (6).
- C. Torque the bolts (1) to between 30-40 lbf.in (3.4-4.5 Nm).
- D. Bond the GPS/WAAS sensor (4) to the aircraft. Refer to [AMM-20-03-00-051-801 – Electrical Bonding - Maintenance Practices](#).
 - (1) Make sure the resistance is not more than 2.5 milliohms.
- E. Remove the protective caps from the electrical connector (2) and Coax Threaded Neil-Concelman (TNC) connector (3).
- F. Connect the electrical connector (2) and Coax TNC connector (3).
- G. Apply power to the aircraft. Refer to [AMM-24-40-00-051-801 – External Power - Maintenance Practices](#).

EFFECTIVITY: ALL

34-50-11
Page 401-Inst
Sep 30/20

- H. Do an adjustment/test of the GPS system. Refer to [AMM-34-50-10-071-801 – GPS - Adjustment/Test](#).

4. Job Close-Up

SUBTASK AMM-34-50-11-041-921-002

- A. Remove all tools, equipment, and unwanted material from the work area.
- B. Install the 231 JZ – Cabin Headliner Assembly. Refer to [AMM-06-50-00-051-801 – Aircraft Access Panels](#).
- C. If all other maintenance is complete, return the aircraft to service. Refer to [AMM-20-00-02-051-801 – Return To Service \(After Maintenance\)](#).

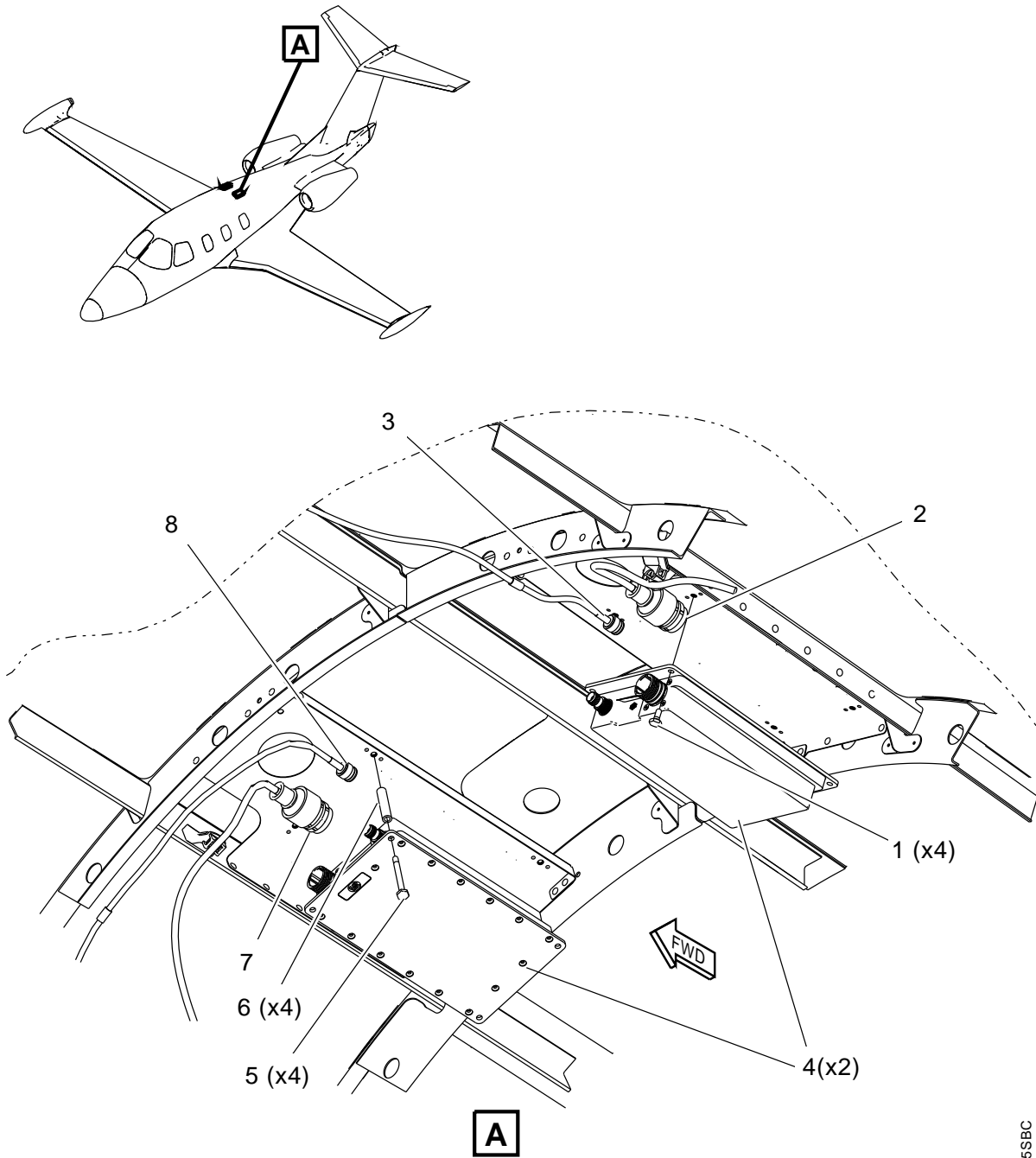

(ROTATED FOR CLARITY)

5A34051335SBC

GPS - Removal/Installation
Figure 401 (Sheet 1 of 1)

THIS PAGE INTENTIONALLY LEFT BLANK

TRANSPONDER - DESCRIPTION AND OPERATION

AMM-34-50-20-081-A-801

1. Introduction

- A. Standard Transponder System with or without Extended Squitter:
- (1) The standard transponder system provides aircraft identification (Mode S) and altitude (Mode C) information to Air Traffic Control.
 - (2) The standard transponder system is made up of the components that follow:
 - Dual standard transponder units installed behind the Primary Flight Displays (PFD)
 - Two transponder antennas
- B. Optional Diversity Transponder System with or without Extended Squitter::
- (1) The diversity transponder system provides aircraft identification (Mode S) and altitude reporting information (Mode C) to Air Traffic Control.
 - (2) The diversity transponder system is made up of the components that follow:
 - Dual diversity transponder units installed behind the PFD.
 - Two transponder antennas
 - Two RF antenna switching relays

2. Description

SUBTASK AMM-34-50-20-081-A-871-001

- A. Standard Transponder System:
- (1) There are two transponders, one (transponder number 1) is installed in the instrument panel behind the left PFD and the other (transponder number 2) is installed in the instrument panel behind the right PFD.
- B. Optional Diversity Transponder System:
- (1) There are two diversity transponders, one (diversity transponder number 1) is installed in the instrument panel behind the left PFD and the other (diversity transponder number 2) is installed in the instrument panel behind the right PFD.
 - (2) There are two RF antenna switching relays, both installed behind the Multi Function Display (MFD). One is inboard of the left diversity transponder and the other is inboard of the right diversity transponder.

3. **Operation**

SUBTASK AMM-34-50-20-081-A-871-002

A. Standard Transponder System:

The two transponder units located behind the left and right PFDs provide identification information (Modes A and S) and altitude reporting information (Mode C).

The rack mounted dual Mode S transponder system are a radio transmitter-receivers that operate on radar frequencies, receiving ground radar and Traffic Collision Avoidance System interrogations at 1030 MHz and transmitting a coded response of pulses on a frequency of 1090 MHz. The transponder is equipped with the IDENT capability that activates the Special Position Identification pulse for 18 seconds. IDENT function is available through the designated button on the respective side grip.

The GTX 33 replies to Mode A, Mode C, and Mode S interrogations. Mode A replies consist of framing pulses and any one of 4,096 codes (also known as "squawk codes"), which differ in the position and number of pulses transmitted. Mode C replies include framing pulses and encoded altitude.

There are two transponder antennas. The number 1 transponder antenna is mounted on the top of the fuselage and is connect to transponder number 1 behind the left PFD. The number 2 transponder antenna is mounted on the lower fuselage and is connect to transponder number 2 behind the right PFD.

B. Optional Diversity Transponder System:

As an option, the transponders allow for antenna diversity feature available through the connection of both antennas to a single transponder unit. this is realized by the RF antenna switching relay and the diversity configuration control bit to the PFD available for configuration though the Aircraft Maintenance Computer (AMC). An active transponder alternates between the top and bottom antennas ensure the quality and reliability of the transponder system communications.

TRANSPONDER - DESCRIPTION AND OPERATION

AMM-34-50-20-081-B-801

1. Introduction

A. Standard Transponder System with Extended Squitter:

- (1) The standard transponder system provides aircraft identification (Mode S), altitude (Mode C), and Automatic Dependent Surveillance Broadcast (ADS-B) OUT information to Air Traffic Control.
- (2) The standard transponder system is made up of the components that follow:
 - Dual standard transponder units with Extended Squitter installed behind the Primary Flight Displays (PFD)
 - Two transponder antennas

B. Optional Diversity Transponder System:

- (1) The diversity transponder system provides aircraft identification (Mode S) and altitude reporting information (Mode C) to Air Traffic Control.
- (2) The diversity transponder system is made up of the components that follow:
 - Dual diversity transponder units installed behind the PFDs
 - Two transponder antennas
 - Two RF antenna switching relays

C. ADS-B Function

The Extended Squitter enabled transponders provide the capabilities of ADS-B technology, which improves situational awareness and flight safety. The ADS-B OUT function is an option and may be activated through the MFD software key pertinent to a specific aircraft registration number.

2. Description

SUBTASK AMM-34-50-20-081-B-871-001

A. Standard Transponder System:

- (1) There are two transponders, one (transponder number 1) is installed in the instrument panel behind the left PFD and the other (transponder number 2) is installed in the instrument panel behind the right PFD.

B. Optional Diversity Transponder System:

- (1) There are two diversity transponders, one (diversity transponder number 1) is installed in the instrument panel behind the left PFD and the other (diversity transponder number 2) is installed in the instrument panel behind the right PFD.
- (2) There are two RF antenna switching relays, both installed behind the Multi Function Display (MFD). One is inboard of the left diversity transponder and the other is inboard of the right diversity transponder.

C. ADS-B Function

The Extended Squitter enabled transponders provide the capabilities of ADS-B technology, which improves situational awareness and flight safety. The ADS-B OUT function is an option and may be activated through the MFD software key pertinent to a specific aircraft registration number.

3. Operation

SUBTASK AMM-34-50-20-081-B-871-002

A. Standard Transponder System:

The two transponder units located behind the left and right PFDs provide identification information (Modes A and S) and altitude reporting information (Mode C).

The rack mounted dual Mode S transponder system are a radio transmitter-receivers that operate on radar frequencies, receiving ground radar and Traffic Collision Avoidance System interrogations at 1030 MHz and transmitting a coded response of pulses on a frequency of 1090 MHz. The transponder is equipped with the IDENT capability that activates the Special Position Identification pulse for 18 seconds. IDENT function is available through the designated button on the respective side grip.

The GTX 33 replies to Mode A, Mode C, and Mode S interrogations. Mode A replies consist of framing pulses and any one of 4,096 codes (also known as "squawk codes"), which differ in the position and number of pulses transmitted. Mode C replies include framing pulses and encoded altitude.

There are two transponder antennas. The number 1 transponder antenna is mounted on the top of the fuselage and is connect to transponder number 1 behind the left PFD. The number 2 transponder antenna is mounted on the lower fuselage and is connect to transponder number 2 behind the right PFD.

B. Optional Diversity Transponder System:

As an option, the transponders allow for antenna diversity feature available through the connection of both antennas to a single transponder unit. this is realized by the RF antenna switching relay and the diversity configuration control bit to the PFD available for configuration though the Aircraft Maintenance Computer (AMC). An active transponder alternates between the top and bottom antennas ensure the quality and reliability of the transponder system communications.

C. ADS-B Function

The Extended Squitter enabled transponders provides the capabilities of ADS-B technology, which improves situational awareness and flight safety. With ADS-B capabilities, position, velocity, and heading information are automatically transmitted to other aircraft and ground stations. The current Air Traffic Control system depends on a transponder request for pertinent aircraft information. ADS-B provides immediate surveillance of air-to-air traffic and aircraft in remote or inhospitable areas not currently covered by radar.

TRANSPONDER - ADJUSTMENT/TEST

AMM-34-50-20-071-801

1. General

- A. This task gives procedures to do the adjustment/test of the:
- Dual Standard (Non-Diversity) Transponder System and components or Optional Dual Diversity Transponder System and components.
 - An adjustment/test is only required for the transponder that is being installed. The opposite transponder, if it has not been removed, does not require an adjustment/test
 - There are two testing methods, the preferred method is with the use of a transponder antenna coupler to limit emissions that may interfere with Air Traffic Control operations and the second method which uses the IFR-6000 antennas.

NOTE: ADS-B test is only required, if the ADS-B function is enabled.

(1) Refer to [Table 501](#) for testing procedures.

Table 501. Test Matrix

| System Test | Procedures |
|--|--|
| Dual Standard Transponder System Test | <p>Std. Transponder 1 <i>Adjustment/Test:</i> SUBTASK AMM-34-50-20-071-701-001-A or SUBTASK AMM-34-50-20-071-701-001-B, and</p> <p>Std. Transponder 2 <i>Adjustment/Test:</i> SUBTASK AMM-34-50-20-071-701-002-A or SUBTASK AMM-34-50-20-071-701-002-B.</p> <p>ADS-B <i>Adjustment Test: (If installed)</i> AMM-34-50-21-071-801 – ADS-B - Adjustment/Test .</p> <p>Transponder Cooling <i>Adjustment/Test:</i> TASK AMM-34-50-24-071-801 .</p> |
| Dual Diversity Transponder System Test | <p>Diversity Transponder 1 <i>Adjustment/Test:</i> SUBTASK AMM-34-50-20-071-701-003-A or SUBTASK AMM-34-50-20-071-701-003-B, and</p> <p>Diversity Transponder 2 <i>Adjustment/Test:</i> SUBTASK AMM-34-50-20-071-701-004-A or SUBTASK AMM-34-50-20-071-701-004-B.</p> <p>ADS-B <i>Adjustment Test: (If installed)</i> AMM-34-50-21-071-801 – ADS-B - Adjustment/Test .</p> <p>Transponder Cooling <i>Adjustment/Test:</i> TASK AMM-34-50-24-071-801 .</p> |

2. **Equipment and Materials**

A. Special Tools and Equipment

Table 502. Special Tools and Equipment

| Name and Part Number |
|--|
| Transponder Test Set (Aeroflex, IFR6000) or equivalent |
| UC-584 Universal Transponder Antenna Coupler Dual Antenna Kit (Viavi 112349)[1] |
| Weight-on-Wheels (WOW) Box (EAI, 87-117390-1001) or AMC 2.4.01 (or higher). |
| Ground Power Unit (GPU). AllStar 450 or AllStar G.S.E. or Hobart GPU-400 or Hobart GPU-600 or Bycan PS-28100 |

[1] For test with UC-584 antenna coupler.

3. Job Set-Up with UC-584 Antenna Coupler

SUBTASK AMM-34-50-20-071-921-001-A

Refer to [Fig. 501](#).

- A. Make aircraft safe for maintenance. Refer to [AMM-20-00-01-051-801 – Make Safe For Maintenance](#).
- B. If on jacks, refer to [AMM-07-10-00-051-801 – Jacking - Maintenance Practices](#) and [AMM-08-20-00-051-801 – Leveling](#).
- C. Connect external power. Refer to [AMM-24-40-00-051-801 – External Power - Maintenance Practices](#). Do not turn on START BATT and SYS BATT switches until prompted.
- D. Prepare Anti-ice system for maintenance. Refer to [AMM-20-00-03-051-801 – Prepare Anti-Ice Systems For Maintenance](#).
- E. Connect Antenna Coupler UC-584S to Aircraft upper Transponder Antenna as follows: (as applicable)

NOTE: For Transponder–1 Adjustment/Test

- (1) Place Antenna Coupler (2) over the antenna (3), guiding antenna in to the slot on the bottom of the coupler.
- (2) Lock Antenna Coupler (2) into place by pushing lever on the side of the coupler into a down and locked position.

NOTE: Coupler must be tightly pressed and locked in place for Test Set to function correctly. Coupler will lock into place when the black rubber gasket is not completely depressed against the aircraft, but the Test Set will not measure functions accurately.

CAUTION: DO NOT CONNECT COAX CABLE TO IFR-6000 ANT PORT. DAMAGE TO EQUIPMENT WILL OCCUR.

- (3) Connect long RF coaxial cable (1) between the Antenna Coupler (2) and Test Set RF I/O Connector.

CAUTION: THE RF COAXIAL CABLE CAN BE A TRIPPING HAZARD. MAKE SURE TO SECURE THE CABLE. PERSONAL INJURY AND DAMAGE TO THE ANTENNAS AND TEST EQUIPMENT COULD OCCUR.

- (4) Temporarily secure the coaxial cable to the aircraft with tape. Tape can be removed after the test is completed.
- (5) Push Antenna Coupler (2) firmly against the aircraft skin until the black rubber gasket on the rim of the coupler is completely depressed tightly against the aircraft.

- F. Connect Antenna Coupler UC-584 to Aircraft lower Transponder Antenna as follows: (as applicable)

NOTE: For Transponder–2 Adjustment/Test

- (1) Place Antenna Coupler (2) over the antenna (4) , guiding antenna in to the slot on the bottom of the coupler.
 - (2) Lock Antenna Coupler (2) into place by pushing lever on the side of the coupler into a down and locked position.

NOTE: Antenna Coupler must be tightly pressed and locked in place for Test Set to function correctly. Coupler will lock into place when the black rubber gasket is not completely depressed against the aircraft, but the Test Set will not measure functions accurately.

CAUTION: DO NOT CONNECT COAX CABLE TO IFR-6000 ANT PORT. DAMAGE TO EQUIPMENT WILL OCCUR.
 - (3) Connect long RF coaxial cable (1) between the Antenna Coupler and Test Set RF I/O Connector.

CAUTION: THE RF COAXIAL CABLE CAN BE A TRIPPING HAZARD. MAKE SURE TO SECURE THE CABLE. PERSONAL INJURY AND DAMAGE TO THE ANTENNAS AND TEST EQUIPMENT COULD OCCUR.
 - (4) Temporarily secure the coaxial cable to the aircraft with tape. Tape can be removed after the test is completed.
 - (5) Push Antenna Coupler (2) firmly against the aircraft skin until the black rubber gasket on the rim of the coupler is completely depressed tightly against the aircraft.
- G. Connect Weight On Wheels (WOW) box or Aircraft Maintenance Computer (AMC) and set switches on Box to W-On-W (on-ground). Refer to [AMM-20-00-04-051-801 – Weight On Wheels \(WOW\) Box - Connect/Disconnect](#).

4. Transponder-1 Adjustment/Test (Standard System) with UC-584 Antenna Coupler

SUBTASK AMM-34-50-20-071-701-001-A

A. Begin adjustment/test as follows:

- (1) Perform Job Set-Up with UC-584 Antenna Coupler, refer to [SUBTASK AMM-34-50-20-071-921-001-A](#).
- (2) Use the small rotary knob on the left PFD to select XPDR page.
NOTE: The XPDR select page will time out and switch back to the COM page after 30 seconds. The operator will have to select XPDR page from time to time during this test.
- (3) Make sure that Transponder 1 (XPDR 1) is ACTIVE transponder in STANDBY MODE.
- (4) Scroll to FLT CTRLS using outer knob. Push inner knob to select. Scroll to the listed ECB using outer knob and highlight. Push “COLLAR” soft key. Push “CONFIRM COLLAR” soft key.
 - ECB - NOSE LDG GEAR (L AFT Bus)
 - ECB - L MAIN LDG GEAR (L AFT Bus)
 - ECB - R MAIN LDG GEAR (L AFT Bus)
- (5) Scroll to ENGINE using outer knob. Push inner knob to select. Scroll to the listed ECB using outer knob and highlight. Push “COLLAR” soft key. Push “CONFIRM COLLAR” soft key.
 - ECB - L ENG FIRE EXTNGR (L FWD Bus)
 - ECB - R ENG FIRE EXTNGR (R FWD Bus)
- (6) Clear any “MASTER CAUTIONS” and “MASTER WARNINGS” as needed.
- (7) Set both left and right PFD baro set to 29.92 (in/Hg) on Autopilot Control Panel (ACP) by pushing BARO SET knob.

B. Transponder-1 Setup

- (1) Use the small rotary knob on the left PFD to select XPDR page.
NOTE: The XPDR select page times out and switches back to the COM page after 30 seconds. Select XPDR page from time to time during this test.
- (2) Make sure that Transponder 1 (XPDR 1) is selected as ACTIVE transponder in STANDBY MODE.
- (3) Push CODE soft key on left PFD and enter the transponder code provided by the control tower for this test. If no code was assigned, enter 1200.

C. Transponder-1 MODE A,C,S Test using Transponder Test Set, IFR6000

- (1) Power up the Transponder Test Set (IFR 6000). After tester performs Self Test, push SETUP button on the test set to bring up the SETUP-XPDR page. If necessary, continue pressing SETUP button until tester cycles to SETUP-XPDR page.

- (2) On the Transponder Test Set (IFR 6000)'s SETUP-XPDR page, use NEXT PARAM or PREV PARAM soft keys to select each parameter, and the "arrow" DATA keys to set the values listed below.
 - RF PORT: DIR W/COUPLER
 - CPL CABLE LOSS: Set to loss found on cable.
 - COUPLER LOSS: Set to loss found on coupler.
 - UUT ADDRESS: AUTO
 - MANUAL AA: Ignore
 - DIVERSITY TEST: OFF
 - CHECK CAP: YES
 - PWR LIM: FAR 43
 - RAD47: OFF.
- (3) Push XPDR button to go to the XPDR-AUTO TEST page.
- (4) Push CONFIG soft key to display the XPDR-CONFIG SCREEN page.
- (5) On the XPDR-CONFIG SCREEN, scroll to GENERIC MODE S using the UP/Down DATA keys.
- (6) With GENERIC MODE S highlighted, push RETURN soft key to confirm selection. This will also cause a return to the XPDR-AUTO TEST page.
- (7) Set the WOW test box or AMC to W-off-W (airborne).

NOTE: Transponders will transition to ALT mode automatically when airborne or simulated airborne (W-off-W).
- (8) Push RUN TEST soft key to start AUTO TEST. The tester will sequence through separate tests, after which a "PASS" message should be displayed.
- (9) Top ERP should be between 48 to 60 dBm and MTL should be between -68 to -80 dBm to PASS.
- (10) Push RUN TEST soft key on Transponder Test Set (IFR 6000) again.
- (11) Make sure the following appears on the Transponder Test Set (IFR 6000):
 - "A CODE" = transponder code entered
 - "C ALT" = left PFD altitude indication +/- 100 ft.
 - "S CODE" = ICAO code assigned to this aircraft/tail number
 - "TAIL" = tail number assigned to this aircraft
 - DF17 DETECTED = YES (IF ADS-B OUT IS INSTALLED) / NO (IF ADS-B OUT IS NOT INSTALLED)
 - "FLT ID" = same as tail number
 - "AA" = ICAO code assigned to this aircraft/tail number (8 digit number in parenthesis)
 - "FS" = IN-AIR

- “VS” = IN-AIR
- (12) On MFD, press SYS along bottom of MFD. Use the small lower knob on the MFD to scroll to the SETUP page. On the SETUP page, press the SETTINGS softkey to bring up the SETTINGS page. At the bottom of the SETTINGS page, verify:
- (a) The “REGISTRATION NO” number (alphanumeric) matches the “TAIL” number (alphanumeric) displayed on the IFR 6000 (above).
 - (b) The “ICAO 24-BIT (OCT)” number matches the “AA” ICAO 24-bit code displayed on the IFR 6000 (above).
- NOTE:** If the aircraft’s registration number and/or ICAO 24-bit (octal) number are not present on the MFD’s SETTINGS page, the Aircraft Configuration File must be updated, refer to [AMM-31-40-00-051-801 – Aircraft Computer Systems - Maintenance Practices](#). Steps (10) through this step must then be repeated.
- (13) On the MFD, scroll to the SETUP tab, press the SENSOR Soft Key. Set the ADC PFD source selection from AUTO to ADC 2.
- (14) On the IFR 6000, press the XPDR button once. Once XPDR – ALT ENCODER is displayed, press the SOURCE SELECT Soft Key until SOURCE - XPDR is displayed. Press the RUN TEST Soft Key.
- (15) Make sure that the altitude reported on IFR 6000 matches L PFD altitude indication +/- 100 ft.
- (16) On the MFD, set the ADC source back to AUTO.
- (17) Set the WOW Box Switches to W-on-W (on-ground).
- (18) Set XPDR 1 to STANDBY MODE.

5. Transponder-2 Adjustment/Test (Standard System) with UC-584 Antenna Coupler

SUBTASK AMM-34-50-20-071-701-002-A

A. Begin adjustment/test as follows:

(1) Perform Job Set-Up with UC-584 Antenna Coupler, refer to [SUBTASK AMM-34-50-20-071-921-001-A](#).

(2) Use the small rotary knob on the left PFD to select XPDR page.

NOTE: The XPDR select page will time out and switch back to the COM page after 30 seconds. The operator will have to select XPDR page from time to time during this test.

(3) Push ACTIVE soft key, upper right button, on the left PFD to select XPDR 2.

(4) Make sure that Transponder 2 (XPDR 2) is in STANDBY MODE.

B. Transponder-2 Setup

(1) Push CODE soft key on right PFD and enter the transponder code provided by the control tower for this test. If no code was assigned, enter 1200.

C. Transponder-2 MODE A,C,S Test using Transponder Test Set, IFR6000

(1) Power up the Transponder Test Set (IFR 6000). After tester performs Self Test, push SETUP button on the test set to bring up the SETUP-XPDR page. If necessary, continue pressing SETUP button until tester cycles to SETUP-XPDR page.

(2) On the Transponder Test Set (IFR 6000) SETUP-XPDR page, use NEXT PARAM or PREV PARAM soft keys to select each parameter, and the "arrow" DATA keys to set the values listed below.

- RF PORT: DIR W/COUPLER
- CPL CABLE LOSS: Set to loss found on cable.
- COUPLER LOSS: Set to loss found on coupler.
- UUT ADDRESS: AUTO
- MANUAL AA: Ignore
- DIVERSITY TEST: OFF
- CHECK CAP: YES
- PWR LIM: FAR 43
- RAD47: OFF.

(3) Push XPDR button to go to the XPDR-AUTO TEST page.

(4) Push CONFIG soft key to display the XPDR-CONFIG SCREEN page.

(5) On the XPDR-CONFIG SCREEN, scroll to GENERIC MODE S using the up/down DATA keys.

(6) With GENERIC MODE S highlighted, push RETURN soft key to confirm selection. This will also cause a return to the XPDR-AUTO TEST page.

(7) Set the WOW Box Switches to W-off-W (airborne).

- (8) Push RUN TEST soft key to start AUTO TEST. The tester will sequence through separate tests, after which a “PASS” message should be displayed.
- (9) Bottom ERP should be between 48 to 60 dBm and MTL should be between -68 to -80 dBm to PASS.
- (10) Make sure the following appears on the Transponder Test Set (IFR 6000):
 - “A CODE” = transponder code entered
 - “C ALT” = left PFD altitude indication +/- 100 ft.
 - “S CODE” = ICAO code assigned to this aircraft/tail number
 - “TAIL” = tail number assigned to this aircraft
 - “FLT ID” = same as tail number
 - DF17 DETECTED” = YES (IF ADS-B OUT IS INSTALLED) / NO (IF ADS-B OUT IS NOT INSTALLED)
 - “AA” = ICAO code assigned to this aircraft/tail number (8 digit number in parenthesis)
 - “FS” = IN-AIR
 - “VS” = IN-AIR
- (11) On MFD, press SYS along bottom of MFD. Use the small lower knob on the MFD to scroll to the SETUP page. On the SETUP page, press the SETTINGS softkey to bring up the SETTINGS page. At the bottom of the SETTINGS page, verify:
 - (a) The “REGISTRATION NO” number (alphanumeric) matches the “TAIL” number (alphanumeric) displayed on the IFR 6000 (above).
- (12) The “ICAO 24-BIT (OCT)” number matches the “AA” ICAO 24-bit code displayed on the IFR 6000 (above).

NOTE: If the aircraft’s registration number and/or ICAO 24-bit (octal) number are not present on the MFD’s SETTINGS page, the Aircraft Configuration File must be updated, refer to [AMM-31-40-00-051-801 – Aircraft Computer Systems - Maintenance Practices](#).
- (13) On the MFD, scroll to the SETUP tab, press the SENSOR Soft Key. Set the ADC PFD source selection from AUTO to ADC 2.
- (14) On the IFR 6000, press the XPDR button once.
- (15) Once XPDR – ALT ENCODER is displayed, press the SOURCE SELECT Soft Key until SOURCE - XPDR is displayed. Press the RUN TEST Soft Key.
- (16) Make sure that an altitude reported on IFR 6000 matches L PFD altitude indication +/- 100 ft.
- (17) On the MFD, set the ADC source back to AUTO.
- (18) Set the WOW Box Switches to W-on-W (on-ground).
- (19) Set XPDR 2 to STANDBY MODE.

6. Diversity Transponder–1 Adjustment/Tests with UC-584 Antenna Coupler

SUBTASK AMM-34-50-20-071-701-003-A

A. Begin adjustment/test as follows:

- (1) Install Antenna Clamp and Shield Assembly (part of Transponder Test Set IFR 6000) on lower transponder antenna (bottom of the center cabin/fuselage), in accordance with instructions in IFR 6000 Ramp Test Set Operation Manual.
 - (a) Position Antenna Clamp inside the slot in the Antenna Shield Plate, aligning captive screws into the respective screw holes.
 - (b) Tighten captive screws.
 - (c) Cover the transponder's Antenna with Antenna Shield. Loosen thumbscrews if necessary.

NOTE: It may be necessary to remove the unit under test's Antenna Guard if access to the transponders Antenna is restricted.
 - (d) Secure Antenna Shield by tightening thumbscrews.
- (2) Perform Job Set-Up with UC-584 Antenna Coupler, refer to [SUBTASK AMM-34-50-20-071-921-001-A](#).
- (3) Push ECB BY SYSTEM soft key. Scroll to FLCS using outer knob. Push inner knob to select. Scroll to the listed ECB using outer knob and highlight. Push “COLLAR” soft key. Push “CONFIRM COLLAR” soft key.
 - ECB - NOSE LDG GEAR (L AFT Bus)
 - ECB - L MAIN LDG GEAR (L AFT Bus)
 - ECB - R MAIN LDG GEAR (L AFT Bus)
- (4) Scroll to ENGINE using outer knob. Push inner knob to select. Scroll to the listed ECB using outer knob and highlight. Push “COLLAR” soft key. Push “CONFIRM COLLAR” soft key.
 - ECB - L ENG FIRE EXTNGR (L FWD Bus)
 - ECB - R ENG FIRE EXTNGR (R FWD Bus)
- (5) Clear any “MASTER CAUTIONS” and “MASTER WARNINGS” as needed.
- (6) Set both left and right PFD baro set to 29.92 (in/Hg.) on Autopilot Control Panel (ACP) by pushing BARO SET knob.
 - Make sure Baro Set on PFD annunciates “29.92 IN”.

B. Diversity Transponder-1 Setup

- (1) Use the small rotary knob on the left PFD to select XPDR page.

NOTE: The XPDR select page times out and switches back to the COM page after 30 seconds. Select XPDR page from time to time during this test.
- (2) Push ACTIVE soft key (upper right button) on the left PFD to select D-XPDR1.
- (3) Make sure that the selected transponder is in Standby Mode.

-
- (4) Push CODE soft key on left PFD and enter the transponder code used for this test or 1200.
- C. Diversity Transponder-1 MODE A,C,S Test using Transponder Test Set, IFR6000 (Upper Antenna)
- (1) Power up the Transponder Test Set (IFR 6000). After tester performs Self Test, push SETUP button on the test set to bring up the SETUP-XPDR page. If necessary, continue pressing SETUP button until tester cycles to SETUP-XPDR page.
 - (2) On the Transponder Test Set (IFR 6000)'s SETUP-XPDR page, use NEXT PARAM or PREV PARAM soft keys to select each parameter, and the "arrow" DATA keys to set the values listed below.
 - RF PORT: DIR W/COUPLER
 - CPL CABLE LOSS: Set to loss found on cable.
 - COUPLER LOSS: Set to loss found on coupler.
 - UUT ADDRESS: AUTO
 - MANUAL AA: Ignore
 - DIVERSITY TEST: ON
 - CHECK CAP: YES
 - PWR LIM: FAR 43
 - RAD47: OFF.
 - (3) Push XPDR button to go to the XPDR-AUTO TEST page.
 - (4) Push CONFIG soft key to display the XPDR-CONFIG SCREEN page.
 - (5) On the XPDR-CONFIG SCREEN, scroll to GENERIC MODE S using the UP/Down DATA keys.
 - (6) With GENERIC MODE S highlighted, push RETURN soft key to confirm selection. This will also cause a return to the XPDR-AUTO TEST page.
 - (7) Set the WOW Box Switches to W-off-W (airborne).
 - (8) Push RUN TEST soft key to start AUTO TEST. The tester will sequence through separate tests, after which a "PASS" message should be displayed.
 - (9) Top ERP should be between 48 to 60 dBm and MTL should be between -68 to -80 dBm to PASS.
 - (10) Make sure the following appears on the Transponder Test Set (IFR 6000):
 - "A CODE" = transponder code entered
 - "C ALT" = left PFD altitude indication +/- 100 ft.
 - "S CODE" = ICAO code assigned to this aircraft/tail number
 - "TAIL" = tail number assigned to this aircraft
 - "FLT ID" = same as tail number

- DF17 DETECTED” = YES (IF ADS-B OUT IS INSTALLED) / NO (IF ADS-B OUT IS NOT INSTALLED)
 - “AA” = ICAO code assigned to this aircraft/tail number (8 digit number in parenthesis)
 - “FS” = IN-AIR
 - “VS” = IN-AIR
- (11) On MFD, press SYS along bottom of MFD. Use the small lower knob on the MFD to scroll to the SETUP page. On the SETUP page, press the SETTINGS soft key to bring up the SETTINGS page. At the bottom of the SETTINGS page, verify:
- (a) The “REGISTRATION NO” number (alphanumeric) matches the “TAIL” number (alphanumeric) displayed on the IFR 6000 (above).
 - (b) The “ICAO 24-BIT (OCT)” number matches the “AA” ICAO 24-bit code displayed on the IFR 6000 (above).
- NOTE: If the aircraft’s registration number and/or ICAO 24-bit (octal) number are not present on the MFD’s SETTINGS page, the Aircraft Configuration File must be updated, refer to [AMM-31-40-00-051-801 – Aircraft Computer Systems - Maintenance Practices](#). Steps (10) through this step must then be repeated.
- (12) On the MFD, scroll to the SETUP tab, press the SENSOR Soft Key. Set the ADC PFD source selection from AUTO to ADC 2.
- (13) On the IFR 6000, press the XPDR button once.
- (14) Once XPDR – ALT ENCODER is displayed, press the SOURCE SELECT Soft Key until SOURCE - XPDR is displayed. Press the RUN TEST Soft Key.
- (15) Make sure that an altitude reported on IFR 6000 matches L PFD altitude indication +/- 100 ft.
- (16) On the MFD, set the ADC source back to AUTO.
- (17) Set the WOW Box Switches to W-on-W (on-ground).
- (18) Set D-XPDR 1 to STANDBY MODE.
- D. Diversity Transponder-1 MODE A,C,S Test using Transponder Test Set (IFR 6000) (Lower Antenna)
- (1) Remove Antenna Clamp and Shield Assembly (part of Transponder Test Set IFR 6000) from lower transponder antenna (bottom center cabin/fuselage).
 - (2) Remove CU-584S Antenna Coupler from upper transponder antenna.
 - (3) Install Antenna Clamp and Shield Assembly (part of Transponder Test Set IFR 6000) on upper transponder antenna (top of the center cabin/fuselage), in accordance with instructions in IFR 6000 Ramp Test Set Operation Manual.
 - (4) Install CU-584 Antenna Coupler on lower transponder antenna. Refer to Job Set-Up with UC-584 Antenna Couplers [SUBTASK AMM-34-50-20-071-921-001-A](#).
 - (5) Push XPDR button to go to the XPDR-AUTO TEST page.
 - (6) Push CONFIG soft key to display the XPDR-CONFIG SCREEN page.

-
- (7) On the XPDR-CONFIG SCREEN, scroll to GENERIC MODE S using the UP/Down DATA keys.
 - (8) With GENERIC MODE S highlighted, push RETURN soft key to confirm selection. This will also cause a return to the XPDR-AUTO TEST page.
 - (9) Set the WOW Box Switches to W-off-W (airborne).
 - (10) Push RUN TEST soft key to start AUTO TEST. The tester will sequence through separate tests, after which a "PASS" message should be displayed.
 - (11) ERP should be between 48 to 60 dBm and MTL should be between -68 to -80 dBm to PASS.
 - (12) Remove Antenna Clamp and Shield Assembly.
 - (13) Remove CU-584 Antenna Coupler from lower transponder antenna.
 - (14) Set the WOW Box Switches to W-on-W (on-ground).

7. Diversity Transponder-2 Adjustment/Tests with UC-584 Antenna Coupler

SUBTASK AMM-34-50-20-071-701-004-A

A. Begin adjustment/test as follows:

- (1) Install Antenna Clamp and Shield Assembly (part of Transponder Test Set IFR 6000) on lower transponder antenna (bottom of the center cabin/fuselage), in accordance with instructions in IFR 6000 Ramp Test Set Operation Manual.
 - (a) Position Antenna Clamp inside the slot in the Antenna Shield Plate, aligning captive screws into the respective screw holes.
 - (b) Tighten captive screws.
 - (c) Cover the transponder's Antenna with Antenna Shield. Loosen thumbscrews if necessary.

NOTE: It may be necessary to remove the unit under test's Antenna Guard if access to the transponders Antenna is restricted.
 - (d) Secure Antenna Shield by tightening thumbscrews.
- (2) Perform Job Set-Up with UC-584 Antenna Coupler, refer to [SUBTASK AMM-34-50-20-071-921-001-A](#).
- (3) Push ECB BY SYSTEM soft key. Scroll to FLCSS using outer knob. Push inner knob to select. Scroll to the listed ECB using outer knob and highlight. Push "COLLAR" soft key. Push "CONFIRM COLLAR" soft key.
 - ECB - NOSE LDG GEAR (L AFT Bus)
 - ECB - L MAIN LDG GEAR (L AFT Bus)
 - ECB - R MAIN LDG GEAR (L AFT Bus)
- (4) Scroll to ENGINE using outer knob. Push inner knob to select. Scroll to the listed ECB using outer knob and highlight. Push "COLLAR" soft key. Push "CONFIRM COLLAR" soft key.
 - ECB - L ENG FIRE EXTNGR (L FWD Bus)
 - ECB - R ENG FIRE EXTNGR (R FWD Bus)
- (5) Clear any "MASTER CAUTIONS" and "MASTER WARNINGS" as needed.
- (6) Set both left and right PFD baro set to 29.92 (in/Hg.) on Autopilot Control Panel (ACP) by pushing BARO SET knob.
 - Make sure Baro Set on PFD annunciates "29.92 IN".

B. Diversity Transponder-2 Setup

- (1) Use the small rotary knob on the left PFD to select XPDR page.

NOTE: The XPDR select page times out and switches back to the COM page after 30 seconds. Select XPDR page from time to time during this test.
- (2) Push ACTIVE soft key (upper right button) on the left PFD to select D-XPDR2.
- (3) Make sure that D-XPDR2 is in Standby Mode.

-
- (4) Push CODE soft key on left PFD and enter the transponder code used for this test or 1200.
- C. Diversity Transponder-2 MODE A,C,S Test using Transponder Test Set, IFR6000 (Upper Antenna)
- (1) Power up the Transponder Test Set (IFR 6000). After tester performs Self Test, push SETUP button on the test set to bring up the SETUP-XPDR page. If necessary, continue pressing SETUP button until tester cycles to SETUP-XPDR page.
 - (2) On the Transponder Test Set (IFR 6000)'s SETUP-XPDR page, use NEXT PARAM or PREV PARAM soft keys to select each parameter, and the "arrow" DATA keys to set the values listed below.
 - RF PORT: DIR W/COUPLER
 - CPL CABLE LOSS: Set to loss found on cable.
 - COUPLER LOSS: Set to loss found on coupler.
 - UUT ADDRESS: AUTO
 - MANUAL AA: Ignore
 - DIVERSITY TEST: ON
 - CHECK CAP: YES
 - PWR LIM: FAR 43
 - RAD47: OFF.
 - (3) Push XPDR button to go to the XPDR-AUTO TEST page.
 - (4) Push CONFIG soft key to display the XPDR-CONFIG SCREEN page.
 - (5) On the XPDR-CONFIG SCREEN, scroll to GENERIC MODE S using the UP/Down DATA keys.
 - (6) With GENERIC MODE S highlighted, push RETURN soft key to confirm selection. This will also cause a return to the XPDR-AUTO TEST page.
 - (7) Set the WOW Box Switches to W-off-W (airborne).
 - (8) Push RUN TEST soft key to start AUTO TEST. The tester will sequence through separate tests, after which a "PASS" message should be displayed.
 - (9) Top ERP should be between 48 to 60 dBm and MTL should be between -68 to -80 dBm to PASS.
 - (10) Make sure the following appears on the Transponder Test Set (IFR 6000):
 - "A CODE" = transponder code entered
 - "C ALT" = left PFD altitude indication +/- 100 ft.
 - "S CODE" = ICAO code assigned to this aircraft/tail number
 - "TAIL" = tail number assigned to this aircraft
 - "DF17 DETECTED" = YES (IF ADS-B OUT IS INSTALLED) / NO (IF ADS-B OUT IS NOT INSTALLED)

- “FLT ID” = same as tail number
 - “AA” = ICAO code assigned to this aircraft/tail number (8 digit number in parenthesis)
 - “FS” = IN-AIR
 - “VS” = IN-AIR
- (11) On MFD, press SYS along bottom of MFD. Use the small lower knob on the MFD to scroll to the SETUP page. On the SETUP page, press the SETTINGS softkey to bring up the SETTINGS page. At the bottom of the SETTINGS page, verify:
- (a) The “REGISTRATION NO” number (alphanumeric) matches the “TAIL” number (alphanumeric) displayed on the IFR 6000 (above).
 - (b) The “ICAO 24-BIT (OCT)” number matches the “AA” ICAO 24-bit code displayed on the IFR 6000 (above).
- NOTE:** If the aircraft’s registration number and/or ICAO 24-bit (octal) number are not present on the MFD’s SETTINGS page, the Aircraft Configuration File must be updated, refer to [AMM-31-40-00-051-801 – Aircraft Computer Systems - Maintenance Practices](#). Steps (10) through this step must then be repeated.
- (12) On the MFD, scroll to the SETUP tab, press the SENSOR Soft Key. Set the ADC PFD source selection from AUTO to ADC 2.
- (13) On the IFR 6000, press the XPDR button once.
- (14) Once XPDR – ALT ENCODER is displayed, press the SOURCE SELECT Soft Key until SOURCE - XPDR is displayed. Press the RUN TEST Soft Key.
- (15) Make sure that an altitude reported on IFR 6000 matches L PFD altitude indication +/- 100 ft.
- (16) On the MFD, set the ADC source back to AUTO.
- (17) Set the WOW Box Switches to W-on-W (on-ground).
- (18) Set D-XPDR 2 to STANDBY MODE.
- D. Diversity Transponder-2 MODE A,C,S Test using Transponder Test Set (IFR 6000) (Lower Antenna)
- (1) Remove Antenna Clamp and Shield Assembly (part of Transponder Test Set IFR 6000) from lower transponder antenna (bottom center cabin/fuselage).
 - (2) Remove CU-584S Antenna Coupler from upper transponder antenna.
 - (3) Install Antenna Clamp and Shield Assembly (part of Transponder Test Set IFR 6000) on upper transponder antenna (top of the center cabin/fuselage), in accordance with instructions in IFR 6000 Ramp Test Set Operation Manual.
 - (4) Install CU-584 Antenna Coupler on lower transponder antenna. Refer to Job Set-Up with UC-584 Antenna Couplers [SUBTASK AMM-34-50-20-071-921-001-A](#).
 - (5) Remove Antenna Clamp and Shield Assembly (part of Transponder Test Set IFR 6000) from lower transponder antenna (bottom of the center cabin/fuselage).

- (6) Install Antenna Clamp and Shield Assembly (part of Transponder Test Set IFR 6000) on upper transponder antenna (top of the center cabin/fuselage), in accordance with instructions in IFR 6000 Ramp Test Set Operation Manual.
- (7) Pre-position the Transponder Test Set IFR 6000 antenna to point at the aircraft's lower Transponder 2 antenna (bottom of the center cabin/fuselage).
- (8) On the Transponder Test Set (IFR 6000) SETUP-XPDR page, use NEXT PARAM or PREV PARAM softkeys to select each parameter, and the "arrow" DATA keys to set the values listed below:
 - ANTENNA: BOTTOM
 - RF PORT: DIR W/COUPLER
 - DIR CABLE LOSS: Ignore
 - CPL CABLE LOSS: Set to loss found on cable.
 - COUPLER LOSS: Set to loss found on coupler.
 - UUT ADDRESS: AUTO
 - MANUAL AA: Ignore
 - DIVERSITY TEST: ON
 - PWR LIM: FAR 43
 - CHECK CAP: YES
- (9) Push XPDR button to go to the XPDR-AUTO TEST page.
- (10) Push CONFIG soft key to display the XPDR-CONFIG SCREEN page.
- (11) On the XPDR-CONFIG SCREEN, scroll to GENERIC MODE S using the UP/Down DATA keys.
- (12) With GENERIC MODE S highlighted, push RETURN soft key to confirm selection. This will also cause a return to the XPDR-AUTO TEST page.
- (13) Set the WOW Box Switches to W-off-W (airborne).
- (14) Push RUN TEST soft key to start AUTO TEST. The tester will sequence through separate tests, after which a "PASS" message should be displayed.
- (15) Bottom ERP should be between 48 to 60 dBm and MTL should be between -68 to -80 dBm to PASS.
- (16) Remove Antenna Clamp and Shield Assembly from aircraft and stow in IFR 6000 ramp test set kit.
- (17) Remove CU-584 Antenna Coupler from lower transponder antenna.
- (18) Set the WOW Box Switches to W-on-W (on-ground).
- (19) Test complete, go to Job Close-up (

8. Job Set-Up with IFR-6000 Test Set Antenna

SUBTASK AMM-34-50-20-071-921-001-B

- A. Make aircraft safe for maintenance. Refer to [AMM-20-00-01-051-801 – Make Safe For Maintenance](#).
- B. If on jacks, refer to [AMM-07-10-00-051-801 – Jacking - Maintenance Practices](#) and [AMM-08-20-00-051-801 – Leveling](#).
- C. Connect external power. Refer to [AMM-24-40-00-051-801 – External Power - Maintenance Practices](#). Do not turn on START BATT and SYS BATT switches until prompted.
- D. Prepare Anti-ice system for maintenance. Refer to [AMM-20-00-03-051-801 – Prepare Anti-Ice Systems For Maintenance](#).
- E. Take proper safety precautions to protect personnel. Position aircraft such that multi-path RF reflections between the IFR-6000 test set, the aircraft's antennas, and surrounding objects are minimized. The area on the left side of the aircraft should not be up against a metal wall or another aircraft. If necessary, position the aircraft outside, away from metal buildings or other aircraft. Refer to [Fig. 502](#).

CAUTION: FAILURE TO COMPLY WITH THIS STEP AND CONTINUING WITH THIS PROCEDURE COULD IMPACT LOCAL AIRPORT TOWER OPERATIONS.

- F. If applicable, contact local airport tower to inform them a transponder test is being run at your location (inside or outside). Request appropriate squawk and allotted time to run test.

NOTE: If local airport tower is not informed, use code 1200.

- G. Attach test set antenna to Transponder Test Set using 1 foot long test set cable (blue cable, supplied if IFR6000 is used), connected to ANT port on tester.
- H. During testing, place the Transponder Test Set antenna approximately two feet to four feet forward and in line with right wing tip tank. May require periodic repositioning between two and four feet.
- I. Connect Weight On Wheels (WOW) box or Aircraft Maintenance Computer (AMC) and set switches on Box to W-On-W (on-ground). Refer to [AMM-20-00-04-051-801 – Weight On Wheels \(WOW\) Box - Connect/Disconnect](#).

9. Transponder-1 Adjustment/Test (Standard System) with IFR-6000 Test Set Antenna

SUBTASK AMM-34-50-20-071-701-001-B

A. Begin adjustment/test as follows:

- (1) Perform job setup, refer to [SUBTASK AMM-34-50-20-071-921-001-B](#).
- (2) Re-align the Transponder Test Set, IFR6000 antenna to point at the aircraft's Transponder-1 antenna (top of the center cabin/fuselage).
- (3) Use the small rotary knob on the left PFD to select XPDR page. NOTE: The XPDR select page will time out and switch back to the COM page after 30 seconds. The operator will have to select XPDR page from time to time during this test.
- (4) Make sure that Transponder 1 (XPDR 1) is ACTIVE transponder in STANDBY MODE.
- (5) Scroll to FLT CTRLS using outer knob. Push inner knob to select. Scroll to the listed ECB using outer knob and highlight. Push "COLLAR" soft key. Push "CONFIRM COLLAR" soft key.
 - ECB - NOSE LDG GEAR (L AFT Bus)
 - ECB - L MAIN LDG GEAR (L AFT Bus)
 - ECB - R MAIN LDG GEAR (L AFT Bus)
- (6) Scroll to ENGINE using outer knob. Push inner knob to select. Scroll to the listed ECB using outer knob and highlight. Push "COLLAR" soft key. Push "CONFIRM COLLAR" soft key.
 - ECB - L ENG FIRE EXTNGR (L FWD Bus)
 - ECB - R ENG FIRE EXTNGR (R FWD Bus)
- (7) Clear any "MASTER CAUTIONS" and "MASTER WARNINGS" as needed.
- (8) Set both left and right PFD baro set to 29.92 (in/Hg) on Autopilot Control Panel (ACP) by pushing BARO SET knob.

B. Transponder-1 Setup

- (1) Use the small rotary knob on the left PFD to select XPDR page.
NOTE: The XPDR select page times out and switches back to the COM page after 30 seconds. Select XPDR page from time to time during this test.
- (2) Make sure that Transponder 1 (XPDR 1) is selected as ACTIVE transponder in STANDBY MODE.
- (3) Push CODE soft key on left PFD and enter the transponder code provided by the control tower for this test. If no code was assigned, enter 1200.

C. Transponder-1 MODE A,C,S Test using Transponder Test Set, IFR6000

- (1) Power up the Transponder Test Set (IFR 6000). After tester performs Self Test, push SETUP button on the test set to bring up the SETUP-XPDR page. If necessary, continue pressing SETUP button until tester cycles to SETUP-XPDR page.

-
- (2) On the Transponder Test Set (IFR 6000)'s SETUP-XPDR page, use NEXT PARAM or PREV PARAM soft keys to select each parameter, and the "arrow" DATA keys to set the values listed below.
 - ANTENNA: TOP
 - RF PORT: ANTENNA
 - ANT RANGE-TOP: 18 ft.
 - ANT HEIGHT-TOP: 7 ft.
 - ANT RANGE-BOTTOM: 18 ft.
 - ANT HEIGHT-BOTTOM: 1 ft.
 - DIR CABLE LOSS: Ignore
 - ANT CABLE: 1 ft.
 - ANT CABLE LOSS: As marked on blue cable (should be 0.1 dB)
 - ANT GAIN (dBi) - 1.03 GHz: As marked on test set antenna
 - ANT GAIN (dBi) - 1.09 GHz: As marked on test set antenna
 - UUT ADDRESS: AUTO
 - MANUAL AA: Ignore
 - DIVERSITY TEST: OFF
 - PWR LIM: FAR 43
 - CHECK CAP: YES
 - (3) Push XPDR button to go to the XPDR-AUTO TEST page.
 - (4) Push CONFIG soft key to display the XPDR-CONFIG SCREEN page.
 - (5) On the XPDR-CONFIG SCREEN, scroll to GENERIC MODE S using the UP/Down DATA keys.
 - (6) With GENERIC MODE S highlighted, push RETURN soft key to confirm selection. This will also cause a return to the XPDR-AUTO TEST page.
 - (7) Set the WOW test box or AMC to W-off-W (airborne).

NOTE: Transponders will transition to ALT mode automatically when airborne or simulated airborne (W-off-W).
 - (8) Push RUN TEST soft key to start AUTO TEST. The tester will sequence through separate tests, after which a "PASS" message should be displayed.

- (9) Top ERP should be between 48 to 60 dBm and MTL should be between -68 to -80 dBm to PASS.

NOTE: If values are obtained and any of the individual tests FAIL during AUTO TEST, press TEST LIST button on IFR 6000 and using UP/DOWN buttons scroll to the specific Failed test(s). Press SELECT TEST button, adjust IFR 6000 test set positioning anywhere within a 30 foot arc between the aircraft's right wingtip and the nose as required, and Press RUN TEST button until PASS Message is received (this may take several test set position adjustments until IFR 6000 and aircraft Transponder "Sync up"). Press STOP TEST button. Repeat until all individual FAILED tests have achieved a PASS. It is not necessary to re-run AUTO TEST. AUTO TEST is a convenience feature only.

NOTE: If POWER/FREQ test Fails: After pressing RUN TEST, adjust IFR-6000 test set positioning while test is running until PASS message appears (this test performs a "Live" update of the dBm values). It may be required to position the test set anywhere within a 30 foot arc between the aircraft's right wingtip and the nose. Press the STOP TEST button as soon as PASS message is displayed

- (10) Push RUN TEST soft key on Transponder Test Set (IFR 6000) again.
- (11) Make sure the following appears on the Transponder Test Set (IFR 6000):
- "A CODE" = transponder code entered
 - "C ALT" = left PFD altitude indication +/- 100 ft.
 - "S CODE" = ICAO code assigned to this aircraft/tail number
 - "TAIL" = tail number assigned to this aircraft
 - DF17 DETECTED = YES (IF ADS-B OUT IS INSTALLED) / NO (IF ADS-B OUT IS NOT INSTALLED)
 - "FLT ID" = same as tail number
 - "AA" = ICAO code assigned to this aircraft/tail number (8 digit number in parenthesis)
 - "FS" = IN-AIR
 - "VS" = IN-AIR
- (12) On MFD, press SYS along bottom of MFD. Use the small lower knob on the MFD to scroll to the SETUP page. On the SETUP page, press the SETTINGS softkey to bring up the SETTINGS page. At the bottom of the SETTINGS page, verify:
- (a) The "REGISTRATION NO" number (alphanumeric) matches the "TAIL" number (alphanumeric) displayed on the IFR 6000 (above).

- (b) The “ICAO 24-BIT (OCT)” number matches the “AA” ICAO 24-bit code displayed on the IFR 6000 (above).

NOTE: If the aircraft’s registration number and/or ICAO 24-bit (octal) number are not present on the MFD’s SETTINGS page, the Aircraft Configuration File must be updated, refer to [AMM-31-40-00-051-801 – Aircraft Computer Systems - Maintenance Practices](#). Steps (10) through this step must then be repeated.

- (13) On the MFD, scroll to the SETUP tab, press the SENSOR Soft Key. Set the ADC PFD source selection from AUTO to ADC 2.
- (14) On the IFR 6000, press the XPDR button once. Once XPDR – ALT ENCODER is displayed, press the SOURCE SELECT Soft Key until SOURCE - XPDR is displayed. Press the RUN TEST Soft Key.
- (15) Make sure that the altitude reported on IFR 6000 matches L PFD altitude indication +/- 100 ft.
- (16) On the MFD, set the ADC source back to AUTO.
- (17) Set the WOW Box Switches to W-on-W (on-ground).
- (18) Set XPDR 1 to STANDBY MODE.

10. Transponder-2 Adjustment/Test (Standard System) with IFR-6000 Test Set Antenna

SUBTASK AMM-34-50-20-071-701-002-B

A. Begin adjustment/test as follows:

- (1) Perform job setup, refer to [SUBTASK AMM-34-50-20-071-921-001-B](#).
- (2) Re-align the Transponder Test Set, IFR6000 antenna to point at the aircraft's lower Transponder-2 antenna (bottom of the center cabin/fuselage).
- (3) Use the small rotary knob on the left PFD to select XPDR page.

NOTE: The XPDR select page will time out and switch back to the COM page after 30 seconds. The operator will have to select XPDR page from time to time during this test.

- (4) Push ACTIVE soft key, upper right button, on the left PFD to select XPDR 2.
- (5) Make sure that Transponder 2 (XPDR 2) is in STANDBY MODE.

B. Transponder-2 Setup

- (1) Push CODE soft key on right PFD and enter the transponder code provided by the control tower for this test. If no code was assigned, enter 1200.

C. Transponder-2 MODE A,C,S Test using Transponder Test Set, IFR6000

- (1) Power up the Transponder Test Set (IFR 6000). After tester performs Self Test, push SETUP button on the test set to bring up the SETUP-XPDR page. If necessary, continue pressing SETUP button until tester cycles to SETUP-XPDR page.
- (2) On the Transponder Test Set (IFR 6000) SETUP-XPDR page, use NEXT PARAM or PREV PARAM soft keys to select each parameter, and the "arrow" DATA keys to set the values listed below.
 - ANTENNA: BOTTOM
 - RF PORT: ANTENNA
 - ANT RANGE-TOP: 18 ft.
 - ANT HEIGHT-BOTTOM: 7 ft.
 - ANT RANGE-BOTTOM: 18 ft.
 - ANT HEIGHT-TOP: 1 ft.
 - DIR CABLE LOSS: Ignore
 - ANT CABLE: 1 ft.
 - ANT CABLE LOSS: As marked on blue cable (should be 0.1 dB)
 - ANT GAIN (dBi) - 1.03 GHz: As marked on test set antenna
 - ANT GAIN (dBi) - 1.09 GHz: As marked on test set antenna
 - UUT ADDRESS: AUTO
 - MANUAL AA: Ignore
 - DIVERSITY TEST: OFF

- PWR LIM: FAR 43
 - CHECK CAP: YES
- (3) Push XPDR button to go to the XPDR-AUTO TEST page.
 - (4) Push CONFIG soft key to display the XPDR-CONFIG SCREEN page.
 - (5) On the XPDR-CONFIG SCREEN, scroll to GENERIC MODE S using the up/down DATA keys.
 - (6) With GENERIC MODE S highlighted, push RETURN soft key to confirm selection. This will also cause a return to the XPDR-AUTO TEST page.
 - (7) Set the WOW Box Switches to W-off-W (airborne).
 - (8) Push RUN TEST soft key to start AUTO TEST. The tester will sequence through separate tests, after which a “PASS” message should be displayed.
 - (9) Bottom ERP should be between 48 to 60 dBm and MTL should be between -68 to -80 dBm to PASS.

NOTE: If values are obtained and any of the individual tests FAIL during AUTO TEST, press TEST LIST button on IFR 6000 and using UP/DOWN buttons scroll to the specific Failed test(s). Press SELECT TEST button, adjust IFR 6000 test set positioning anywhere within a 30 foot arc between the aircraft’s right wingtip and the nose as required, and Press RUN TEST button until PASS Message is received (this may take several test set position adjustments until IFR 6000 and aircraft Transponder “Sync up”). Press STOP TEST button. Repeat until all individual FAILED tests have achieved a PASS. It is not necessary to re-run AUTO TEST. AUTO TEST is a convenience feature only.

NOTE: If POWER/FREQ test Fails: After pressing RUN TEST, adjust IFR-6000 test set positioning while test is running until PASS message appears (this test performs a “Live” update of the dBm values). It may be required to position the test set anywhere within a 30 foot arc between the aircraft’s right wingtip and the nose. Press the STOP TEST button as soon as PASS message is displayed.

- (10) Make sure the following appears on the Transponder Test Set (IFR 6000):
 - “A CODE” = transponder code entered
 - “C ALT” = left PFD altitude indication +/- 100 ft.
 - “S CODE” = ICAO code assigned to this aircraft/tail number
 - “TAIL” = tail number assigned to this aircraft
 - “FLT ID” = same as tail number
 - “DF17 DETECTED” = YES (IF ADS-B OUT IS INSTALLED) / NO (IF ADS-B OUT IS NOT INSTALLED)
 - “AA” = ICAO code assigned to this aircraft/tail number (8 digit number in parenthesis)
 - “FS” = IN-AIR
 - “VS” = IN-AIR

(11) On MFD, press SYS along bottom of MFD. Use the small lower knob on the MFD to scroll to the SETUP page. On the SETUP page, press the SETTINGS softkey to bring up the SETTINGS page. At the bottom of the SETTINGS page, verify:

(a) The “REGISTRATION NO” number (alphanumeric) matches the “TAIL” number (alphanumeric) displayed on the IFR 6000 (above).

(12) The “ICAO 24-BIT (OCT)” number matches the “AA” ICAO 24-bit code displayed on the IFR 6000 (above).

NOTE: If the aircraft’s registration number and/or ICAO 24-bit (octal) number are not present on the MFD’s SETTINGS page, the Aircraft Configuration File must be updated, refer to [AMM-31-40-00-051-801 – Aircraft Computer Systems - Maintenance Practices](#).

(13) On the MFD, scroll to the SETUP tab, press the SENSOR Soft Key. Set the ADC PFD source selection from AUTO to ADC 2.

(14) On the IFR 6000, press the XPDR button once.

(15) Once XPDR – ALT ENCODER is displayed, press the SOURCE SELECT Soft Key until SOURCE - XPDR is displayed. Press the RUN TEST Soft Key.

(16) Make sure that an altitude reported on IFR 6000 matches L PFD altitude indication +/- 100 ft.

(17) On the MFD, set the ADC source back to AUTO.

(18) Set the WOW Box Switches to W-on-W (on-ground).

(19) Set XPDR 2 to STANDBY MODE.

11. Diversity Transponder–1 Adjustment/Tests with IFR-6000 Test Set Antenna

SUBTASK AMM-34-50-20-071-701-003-B

A. Begin adjustment/test as follows:

(1) Install Antenna Clamp and Shield Assembly (part of Transponder Test Set IFR 6000) on lower transponder antenna (bottom of the center cabin/fuselage), in accordance with instructions in IFR 6000 Ramp Test Set Operation Manual.

(a) Position Antenna Clamp inside the slot in the Antenna Shield Plate, aligning captive screws into the respective screw holes.

(b) Tighten captive screws.

(c) Cover the transponder's Antenna with Antenna Shield. Loosen thumbscrews if necessary.

NOTE: It may be necessary to remove the unit under test's Antenna Guard if access to the transponders Antenna is restricted.

(d) Secure Antenna Shield by tightening thumbscrews.

(2) Perform job setup, refer to [SUBTASK AMM-34-50-20-071-921-001-B](#).

(3) Push ECB BY SYSTEM soft key. Scroll to FLCSS using outer knob. Push inner knob to select. Scroll to the listed ECB using outer knob and highlight. Push "COLLAR" soft key. Push "CONFIRM COLLAR" soft key.

- ECB - NOSE LDG GEAR (L AFT Bus)
- ECB - L MAIN LDG GEAR (L AFT Bus)
- ECB - R MAIN LDG GEAR (L AFT Bus)

(4) Scroll to ENGINE using outer knob. Push inner knob to select. Scroll to the listed ECB using outer knob and highlight. Push "COLLAR" soft key. Push "CONFIRM COLLAR" soft key.

- ECB - L ENG FIRE EXTNGR (L FWD Bus)
- ECB - R ENG FIRE EXTNGR (R FWD Bus)

(5) Clear any "MASTER CAUTIONS" and "MASTER WARNINGS" as needed.

(6) Set both left and right PFD baro set to 29.92 (in/Hg.) on Autopilot Control Panel (ACP) by pushing BARO SET knob.

- Make sure Baro Set on PFD annunciates "29.92 IN".

B. Diversity Transponder-1 Setup

(1) Use the small rotary knob on the left PFD to select XPDR page.

NOTE: The XPDR select page times out and switches back to the COM page after 30 seconds. Select XPDR page from time to time during this test.

(2) Push ACTIVE soft key (upper right button) on the left PFD to select D-XPDR1.

(3) Make sure that the selected transponder is in Standby Mode.

-
- (4) Push CODE soft key on left PFD and enter the transponder code used for this test or 1200.
- C. Diversity Transponder-1 MODE A,C,S Test using Transponder Test Set, IFR6000 (Upper Antenna)
- (1) Power up the Transponder Test Set (IFR 6000). After tester performs Self Test, push SETUP button on the test set to bring up the SETUP-XPDR page. If necessary, continue pressing SETUP button until tester cycles to SETUP-XPDR page.
- (2) On the Transponder Test Set (IFR 6000)'s SETUP-XPDR page, use NEXT PARAM or PREV PARAM soft keys to select each parameter, and the "arrow" DATA keys to set the values listed below.
- ANTENNA: TOP
 - RF PORT: ANTENNA
 - ANT RANGE-TOP: 18 ft.
 - ANT HEIGHT-TOP: 7 ft.
 - ANT RANGE-BOTTOM: 18 ft.
 - ANT HEIGHT-BOTTOM: 1 ft.
 - DIR CABLE LOSS: Ignore
 - ANT CABLE: 1 ft.
 - ANT CABLE LOSS: As marked on blue cable (should be 0.1 dB)
 - ANT GAIN (dBi) - 1.03 GHz: As marked on test set antenna
 - ANT GAIN (dBi) - 1.09 GHz: As marked on test set antenna
 - UUT ADDRESS: AUTO
 - MANUAL AA: Ignore
 - DIVERSITY TEST: ON
 - PWR LIM: FAR 43
 - CHECK CAP: YES
- (3) Push XPDR button to go to the XPDR-AUTO TEST page.
- (4) Push CONFIG soft key to display the XPDR-CONFIG SCREEN page.
- (5) On the XPDR-CONFIG SCREEN, scroll to GENERIC MODE S using the UP/Down DATA keys.
- (6) With GENERIC MODE S highlighted, push RETURN soft key to confirm selection. This will also cause a return to the XPDR-AUTO TEST page.
- (7) Set the WOW Box Switches to W-off-W (airborne).
- (8) Push RUN TEST soft key to start AUTO TEST. The tester will sequence through separate tests, after which a "PASS" message should be displayed.

- (9) Top ERP should be between 48 to 60 dBm and MTL should be between -68 to -80 dBm to PASS.

NOTE: If values are obtained and any of the individual tests FAIL during AUTO TEST, press TEST LIST button on IFR 6000 and using UP/DOWN buttons scroll to the specific Failed test(s). Press SELECT TEST button, adjust IFR 6000 test set positioning anywhere within a 30 foot arc between the aircraft's right wingtip and the nose as required, and Press RUN TEST button until PASS Message is received (this may take several test set position adjustments until IFR 6000 and aircraft Transponder "Sync up"). Press STOP TEST button. Repeat until all individual FAILED tests have achieved a PASS. It is not necessary to re-run AUTO TEST. AUTO TEST is a convenience feature only.

NOTE: If POWER/FREQ test Fails: After pressing RUN TEST, adjust IFR-6000 test set positioning while test is running until PASS message appears (this test performs a "Live" update of the dBm values). It may be required to position the test set anywhere within a 30 foot arc between the aircraft's right wingtip and the nose. Press the STOP TEST button as soon as PASS message is displayed

- (10) Make sure the following appears on the Transponder Test Set (IFR 6000):
- "A CODE" = transponder code entered
 - "C ALT" = left PFD altitude indication +/- 100 ft.
 - "S CODE" = ICAO code assigned to this aircraft/tail number
 - "TAIL" = tail number assigned to this aircraft
 - "FLT ID" = same as tail number
 - "DF17 DETECTED" = YES (IF ADS-B OUT IS INSTALLED) / NO (IF ADS-B OUT IS NOT INSTALLED)
 - "AA" = ICAO code assigned to this aircraft/tail number (8 digit number in parenthesis)
 - "FS" = IN-AIR
 - "VS" = IN-AIR
- (11) On MFD, press SYS along bottom of MFD. Use the small lower knob on the MFD to scroll to the SETUP page. On the SETUP page, press the SETTINGS soft key to bring up the SETTINGS page. At the bottom of the SETTINGS page, verify:
- (a) The "REGISTRATION NO" number (alphanumeric) matches the "TAIL" number (alphanumeric) displayed on the IFR 6000 (above).
- (b) The "ICAO 24-BIT (OCT)" number matches the "AA" ICAO 24-bit code displayed on the IFR 6000 (above).

NOTE: If the aircraft's registration number and/or ICAO 24-bit (octal) number are not present on the MFD's SETTINGS page, the Aircraft Configuration File must be updated, refer to [AMM-31-40-00-051-801 – Aircraft Computer Systems - Maintenance Practices](#). Steps (10) through this step must then be repeated.

- (12) On the MFD, scroll to the SETUP tab, press the SENSOR Soft Key. Set the ADC PFD source selection from AUTO to ADC 2.
 - (13) On the IFR 6000, press the XPDR button once.
 - (14) Once XPDR – ALT ENCODER is displayed, press the SOURCE SELECT Soft Key until SOURCE - XPDR is displayed. Press the RUN TEST Soft Key.
 - (15) Make sure that an altitude reported on IFR 6000 matches L PFD altitude indication +/- 100 ft.
 - (16) On the MFD, set the ADC source back to AUTO.
 - (17) Set the WOW Box Switches to W-on-W (on-ground).
 - (18) Set D-XPDR 1 to STANDBY MODE.
- D. Diversity Transponder-1 MODE A,C,S Test using Transponder Test Set (IFR 6000) (Lower Antenna)
- (1) Remove Antenna Clamp and Shield Assembly (part of Transponder Test Set IFR 6000) from lower transponder antenna (bottom center cabin/fuselage).
 - (2) Install Antenna Clamp and Shield Assembly (part of Transponder Test Set IFR 6000) on upper transponder antenna (top of the center cabin/fuselage), in accordance with instructions in IFR 6000 Ramp Test Set Operation Manual.
 - (3) Pre-position the Transponder Test Set IFR 6000 antenna to point at the aircraft's lower Transponder 2 antenna, (bottom of the center cabin/fuselage).
 - (4) Push XPDR button to go to the XPDR-AUTO TEST page.
 - (5) Push CONFIG soft key to display the XPDR-CONFIG SCREEN page.
 - (6) On the XPDR-CONFIG SCREEN, scroll to GENERIC MODE S using the UP/Down DATA keys.
 - (7) With GENERIC MODE S highlighted, push RETURN soft key to confirm selection. This will also cause a return to the XPDR-AUTO TEST page.
 - (8) Set the WOW Box Switches to W-off-W (airborne).
 - (9) Push RUN TEST soft key to start AUTO TEST. The tester will sequence through separate tests, after which a "PASS" message should be displayed.

- (10) ERP should be between 48 to 60 dBm and MTL should be between -68 to -80 dBm to PASS.

NOTE: If values are obtained and any of the individual tests FAIL during AUTO TEST, press TEST LIST button on IFR 6000 and using UP/DOWN buttons scroll to the specific Failed test(s). Press SELECT TEST button, adjust IFR 6000 test set positioning anywhere within a 30 foot arc between the aircraft's right wingtip and the nose as required, and Press RUN TEST button until PASS Message is received (this may take several test set position adjustments until IFR 6000 and aircraft Transponder "Sync up"). Press STOP TEST button. Repeat until all individual FAILED tests have achieved a PASS. It is not necessary to re-run AUTO TEST. AUTO TEST is a convenience feature only.

NOTE: If POWER/FREQ test Fails: After pressing RUN TEST, adjust IFR-6000 test set positioning while test is running until PASS message appears (this test performs a "Live" update of the dBm values). It may be required to position the test set anywhere within a 30 foot arc between the aircraft's right wingtip and the nose. Press the STOP TEST button as soon as PASS message is displayed

- (11) Remove Antenna Clamp and Shield Assembly.
- (12) Set the WOW Box Switches to W-on-W (on-ground).

12. Diversity Transponder–2 Adjustment/Tests with IFR-6000 Test Set Antenna

SUBTASK AMM-34-50-20-071-701-004-B

A. Begin adjustment/test as follows:

(1) Install Antenna Clamp and Shield Assembly (part of Transponder Test Set IFR 6000) on lower transponder antenna (bottom of the center cabin/fuselage), in accordance with instructions in IFR 6000 Ramp Test Set Operation Manual.

(a) Position Antenna Clamp inside the slot in the Antenna Shield Plate, aligning captive screws into the respective screw holes.

(b) Tighten captive screws.

(c) Cover the transponder's Antenna with Antenna Shield. Loosen thumbscrews if necessary.

NOTE: It may be necessary to remove the unit under test's Antenna Guard if access to the transponders Antenna is restricted.

(d) Secure Antenna Shield by tightening thumbscrews.

(2) Perform job setup, refer to [SUBTASK AMM-34-50-20-071-921-001-B](#).

(3) Push ECB BY SYSTEM soft key. Scroll to FLCSS using outer knob. Push inner knob to select. Scroll to the listed ECB using outer knob and highlight. Push "COLLAR" soft key. Push "CONFIRM COLLAR" soft key.

- ECB - NOSE LDG GEAR (L AFT Bus)
- ECB - L MAIN LDG GEAR (L AFT Bus)
- ECB - R MAIN LDG GEAR (L AFT Bus)

(4) Scroll to ENGINE using outer knob. Push inner knob to select. Scroll to the listed ECB using outer knob and highlight. Push "COLLAR" soft key. Push "CONFIRM COLLAR" soft key.

- ECB - L ENG FIRE EXTNGR (L FWD Bus)
- ECB - R ENG FIRE EXTNGR (R FWD Bus)

(5) Clear any "MASTER CAUTIONS" and "MASTER WARNINGS" as needed.

(6) Set both left and right PFD baro set to 29.92 (in/Hg.) on Autopilot Control Panel (ACP) by pushing BARO SET knob.

- Make sure Baro Set on PFD annunciates "29.92 IN".

B. Diversity Transponder-2 Setup

(1) Use the small rotary knob on the left PFD to select XPDR page.

NOTE: The XPDR select page times out and switches back to the COM page after 30 seconds. Select XPDR page from time to time during this test.

(2) Push ACTIVE soft key (upper right button) on the left PFD to select D-XPDR2.

(3) Make sure that D-XPDR2 is in Standby Mode.

-
- (4) Push CODE soft key on left PFD and enter the transponder code used for this test or 1200.
- C. Diversity Transponder-2 MODE A,C,S Test using Transponder Test Set, IFR6000 (Upper Antenna)
- (1) Power up the Transponder Test Set (IFR 6000). After tester performs Self Test, push SETUP button on the test set to bring up the SETUP-XPDR page. If necessary, continue pressing SETUP button until tester cycles to SETUP-XPDR page.
 - (2) On the Transponder Test Set (IFR 6000)'s SETUP-XPDR page, use NEXT PARAM or PREV PARAM soft keys to select each parameter, and the "arrow" DATA keys to set the values listed below.
 - ANTENNA: TOP
 - RF PORT: ANTENNA
 - ANT RANGE-TOP: 18 ft.
 - ANT HEIGHT-TOP: 7 ft.
 - ANT RANGE-BOTTOM: 18 ft.
 - ANT HEIGHT-BOTTOM: 1 ft.
 - DIR CABLE LOSS: Ignore
 - ANT CABLE: 1 ft.
 - ANT CABLE LOSS: As marked on blue cable (should be 0.1 dB)
 - ANT GAIN (dBi) - 1.03 GHz: As marked on test set antenna
 - ANT GAIN (dBi) - 1.09 GHz: As marked on test set antenna
 - UUT ADDRESS: AUTO
 - MANUAL AA: Ignore
 - DIVERSITY TEST: ON
 - PWR LIM: FAR 43
 - CHECK CAP: YES
 - (3) Push XPDR button to go to the XPDR-AUTO TEST page.
 - (4) Push CONFIG soft key to display the XPDR-CONFIG SCREEN page.
 - (5) On the XPDR-CONFIG SCREEN, scroll to GENERIC MODE S using the UP/Down DATA keys.
 - (6) With GENERIC MODE S highlighted, push RETURN soft key to confirm selection. This will also cause a return to the XPDR-AUTO TEST page.
 - (7) Set the WOW Box Switches to W-off-W (airborne).
 - (8) Push RUN TEST soft key to start AUTO TEST. The tester will sequence through separate tests, after which a "PASS" message should be displayed.

- (9) Top ERP should be between 48 to 60 dBm and MTL should be between -68 to -80 dBm to PASS.

NOTE: If values are obtained and any of the individual tests FAIL during AUTO TEST, press TEST LIST button on IFR 6000 and using UP/DOWN buttons scroll to the specific Failed test(s). Press SELECT TEST button, adjust IFR 6000 test set positioning anywhere within a 30 foot arc between the aircraft's right wingtip and the nose as required, and Press RUN TEST button until PASS Message is received (this may take several test set position adjustments until IFR 6000 and aircraft Transponder "Sync up"). Press STOP TEST button. Repeat until all individual FAILED tests have achieved a PASS. It is not necessary to re-run AUTO TEST. AUTO TEST is a convenience feature only.

NOTE: If POWER/FREQ test Fails: After pressing RUN TEST, adjust IFR-6000 test set positioning while test is running until PASS message appears (this test performs a "Live" update of the dBm values). It may be required to position the test set anywhere within a 30 foot arc between the aircraft's right wingtip and the nose. Press the STOP TEST button as soon as PASS message is displayed

- (10) Make sure the following appears on the Transponder Test Set (IFR 6000):
- "A CODE" = transponder code entered
 - "C ALT" = left PFD altitude indication +/- 100 ft.
 - "S CODE" = ICAO code assigned to this aircraft/tail number
 - "TAIL" = tail number assigned to this aircraft
 - "DF17 DETECTED" = YES (IF ADS-B OUT IS INSTALLED) / NO (IF ADS-B OUT IS NOT INSTALLED)
 - "FLT ID" = same as tail number
 - "AA" = ICAO code assigned to this aircraft/tail number (8 digit number in parenthesis)
 - "FS" = IN-AIR
 - "VS" = IN-AIR
- (11) On MFD, press SYS along bottom of MFD. Use the small lower knob on the MFD to scroll to the SETUP page. On the SETUP page, press the SETTINGS softkey to bring up the SETTINGS page. At the bottom of the SETTINGS page, verify:
- (a) The "REGISTRATION NO" number (alphanumeric) matches the "TAIL" number (alphanumeric) displayed on the IFR 6000 (above).
 - (b) The "ICAO 24-BIT (OCT)" number matches the "AA" ICAO 24-bit code displayed on the IFR 6000 (above).

NOTE: If the aircraft's registration number and/or ICAO 24-bit (octal) number are not present on the MFD's SETTINGS page, the Aircraft Configuration File must be updated, refer to [AMM-31-40-00-051-801 – Aircraft Computer Systems - Maintenance Practices](#). Steps (10) through this step must then be repeated.

- (12) On the MFD, scroll to the SETUP tab, press the SENSOR Soft Key. Set the ADC PFD source selection from AUTO to ADC 2.
 - (13) On the IFR 6000, press the XPDR button once.
 - (14) Once XPDR – ALT ENCODER is displayed, press the SOURCE SELECT Soft Key until SOURCE - XPDR is displayed. Press the RUN TEST Soft Key.
 - (15) Make sure that an altitude reported on IFR 6000 matches L PFD altitude indication +/- 100 ft.
 - (16) On the MFD, set the ADC source back to AUTO.
 - (17) Set the WOW Box Switches to W-on-W (on-ground).
 - (18) Set D-XPDR 2 to STANDBY MODE.
- D. Diversity Transponder-2 MODE A,C,S Test using Transponder Test Set (IFR 6000) (Lower Antenna)
- (1) Remove Antenna Clamp and Shield Assembly (part of Transponder Test Set IFR 6000) from lower transponder antenna (bottom of the center cabin/fuselage).
 - (2) Install Antenna Clamp and Shield Assembly (part of Transponder Test Set IFR 6000) on upper transponder antenna (top of the center cabin/fuselage), in accordance with instructions in IFR 6000 Ramp Test Set Operation Manual.
 - (3) Pre-position the Transponder Test Set IFR 6000 antenna to point at the aircraft's lower Transponder 2 antenna (bottom of the center cabin/fuselage).
 - (4) On the Transponder Test Set (IFR 6000) SETUP-XPDR page, use NEXT PARAM or PREV PARAM softkeys to select each parameter, and the "arrow" DATA keys to set the values listed below:
 - ANTENNA: BOTTOM
 - RF PORT: ANTENNA
 - ANT RANGE-TOP: 18 ft.
 - ANT HEIGHT-TOP: 7 ft.
 - ANT RANGE-BOTTOM: 18 ft.
 - ANT HEIGHT-BOTTOM: 1 ft.
 - DIR CABLE LOSS: Ignore
 - ANT CABLE: 1 ft.
 - ANT CABLE LOSS: As marked on blue cable (should be 0.1 dB)
 - ANT GAIN (dBi) - 1.03 GHz: As marked on test set antenna
 - ANT GAIN (dBi) - 1.09 GHz: As marked on test set antenna
 - UUT ADDRESS: AUTO
 - MANUAL AA: Ignore
 - DIVERSITY TEST: ON
 - PWR LIM: FAR 43

- CHECK CAP: YES
- (5) Push XPDR button to go to the XPDR-AUTO TEST page.
 - (6) Push CONFIG soft key to display the XPDR-CONFIG SCREEN page.
 - (7) On the XPDR-CONFIG SCREEN, scroll to GENERIC MODE S using the UP/Down DATA keys.
 - (8) With GENERIC MODE S highlighted, push RETURN soft key to confirm selection. This will also cause a return to the XPDR-AUTO TEST page.
 - (9) Set the WOW Box Switches to W-off-W (airborne).
 - (10) Push RUN TEST soft key to start AUTO TEST. The tester will sequence through separate tests, after which a “PASS” message should be displayed.
 - (11) Bottom ERP should be between 48 to 60 dBm and MTL should be between -68 to -80 dBm to PASS.

NOTE: If values are obtained and any of the individual tests FAIL during AUTO TEST, press TEST LIST button on IFR 6000 and using UP/DOWN buttons scroll to the specific Failed test(s). Press SELECT TEST button, adjust IFR 6000 test set positioning anywhere within a 30 foot arc between the aircraft’s right wingtip and the nose as required, and Press RUN TEST button until PASS Message is received (this may take several test set position adjustments until IFR 6000 and aircraft Transponder “Sync up”). Press STOP TEST button. Repeat until all individual FAILED tests have achieved a PASS. It is not necessary to re-run AUTO TEST. AUTO TEST is a convenience feature only.

NOTE: If POWER/FREQ test Fails: After pressing RUN TEST, adjust IFR-6000 test set positioning while test is running until PASS message appears (this test performs a “Live” update of the dBm values). It may be required to position the test set anywhere within a 30 foot arc between the aircraft’s right wingtip and the nose. Press the STOP TEST button as soon as PASS message is displayed

- (12) Remove Antenna Clamp and Shield Assembly from aircraft and stow in IFR 6000 ramp test set kit.
- (13) Set the WOW Box Switches to W-on-W (on-ground).

13. Job Close-Up

SUBTASK AMM-34-50-20-071-921-005

- A. Set WOW Box switches to W-on-W (on-ground)
- B. Reset the collared ECB's. Refer to AMM-20-00-03-051-801 – Prepare Anti-Ice Systems For Maintenance.
- C. Scroll to FLCs using outer knob. Press inner knob to select. Scroll to the listed ECB using outer knob and highlight. Push “RESET” Soft key. Press “CONFIRM RESET” soft key.
 - ECB - NOSE LDG GEAR (L AFT Bus)
 - ECB - L MAIN LDG GEAR (L AFT Bus)
 - ECB - R MAIN LDG GEAR (L AFT Bus)
- D. Scroll to ENGINE using outer knob. Press inner knob to select. Scroll to the listed ECB using outer knob and highlight. Push “RESET” Soft key. Press “CONFIRM RESET” soft key.
 - ECB - L ENG FIRE EXTNGR (L FWD Bus)
 - ECB - R ENG FIRE EXTNGR (R FWD Bus)
- E. Power down the aircraft by setting the SYS BATT and START BATT switches to OFF and the BUS TIE to OPEN.
- F. Disconnect WOW Box from aircraft. Refer to AMM-20-00-04-051-801 – Weight On Wheels (WOW) Box - Connect/Disconnect.
- G. If on jacks, lower aircraft and remove jacks. Refer to [AMM-07-10-00-051-801 – Jacking - Maintenance Practices](#).
- H. If applicable, call the local control tower and tell them the transponder test is complete.
- I. Remove all tools, equipment and unwanted material from work area.
- J. Disconnect external power. Refer to [AMM-24-40-00-051-801 – External Power - Maintenance Practices](#).
- K. If all other maintenance is complete, return aircraft to service. Refer to [AMM-20-00-02-051-801 – Return To Service \(After Maintenance\)](#).

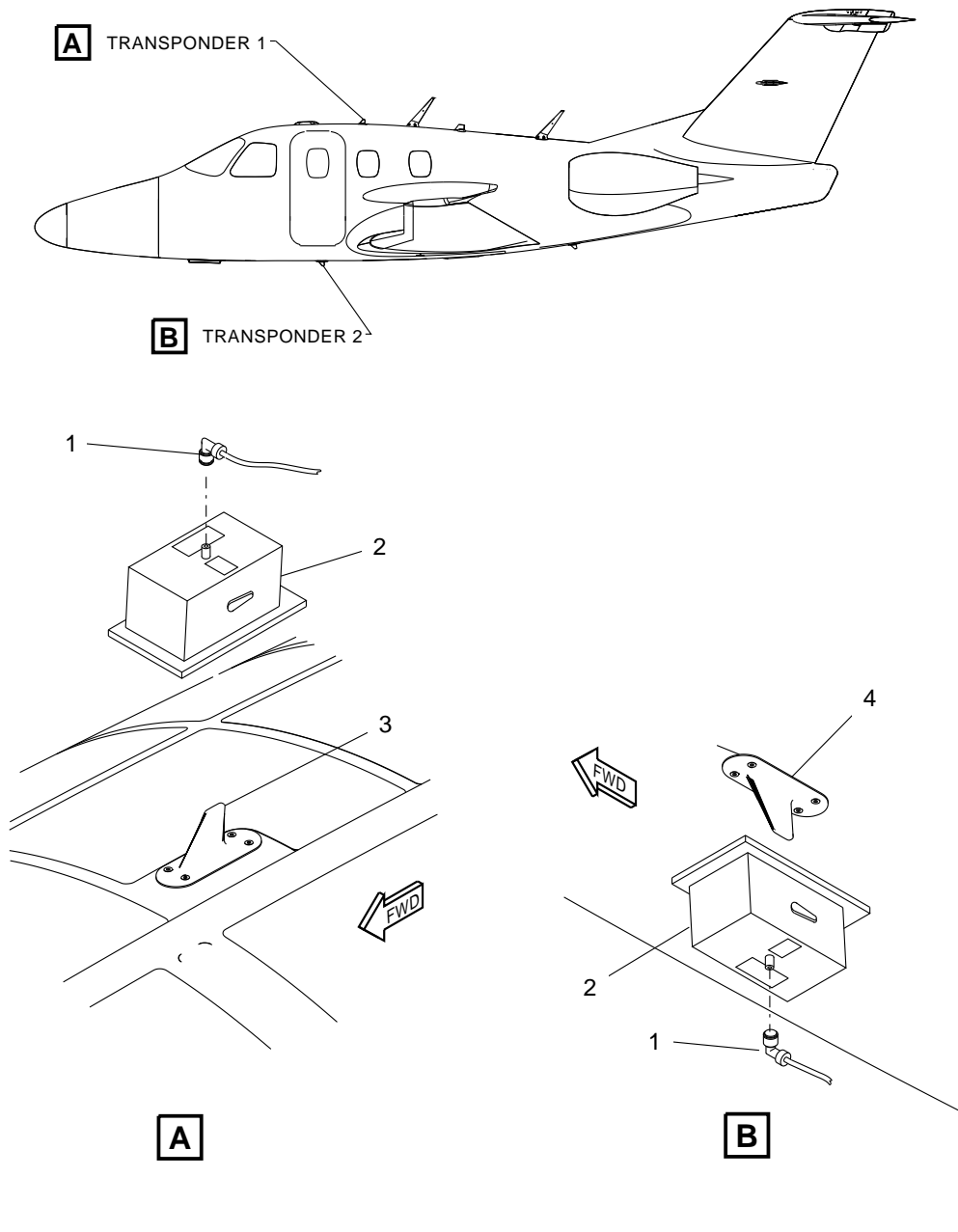

**Transponder - Adjustment/Test
Figure 501 (Sheet 1 of 1)**

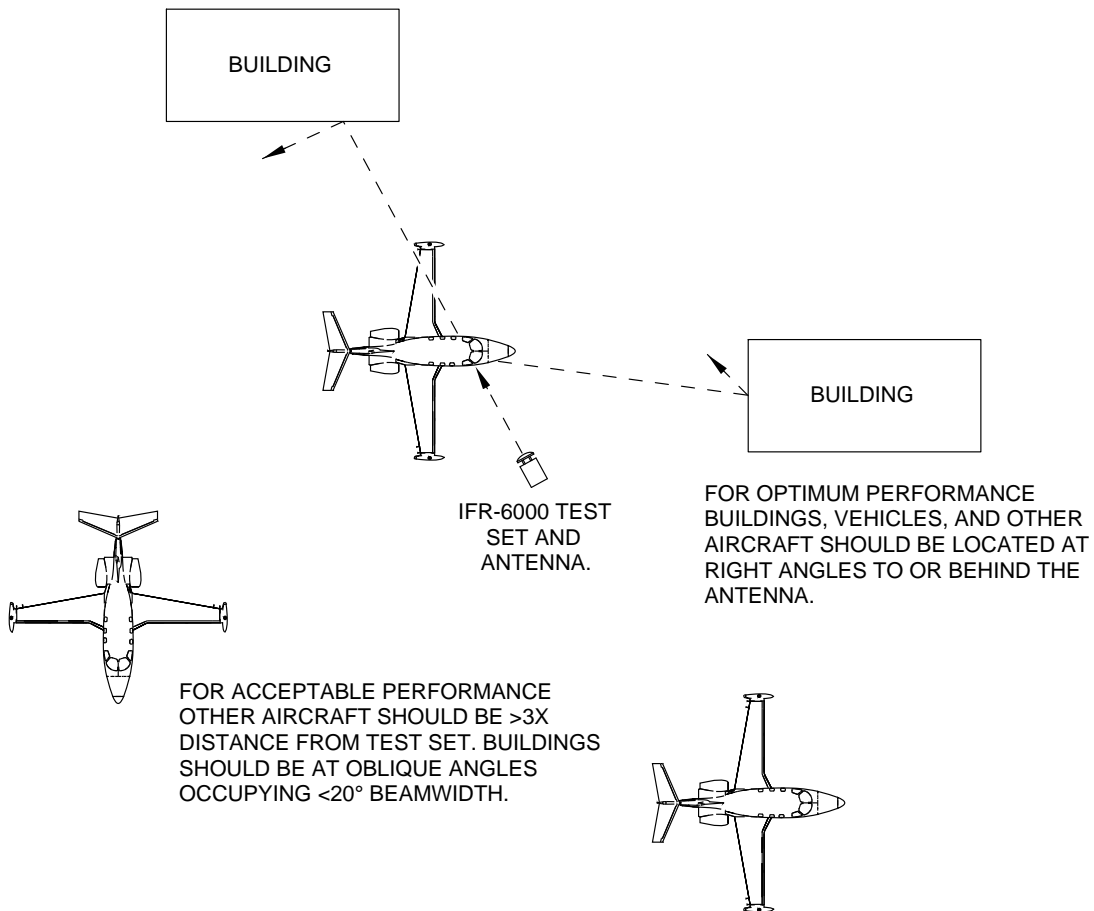
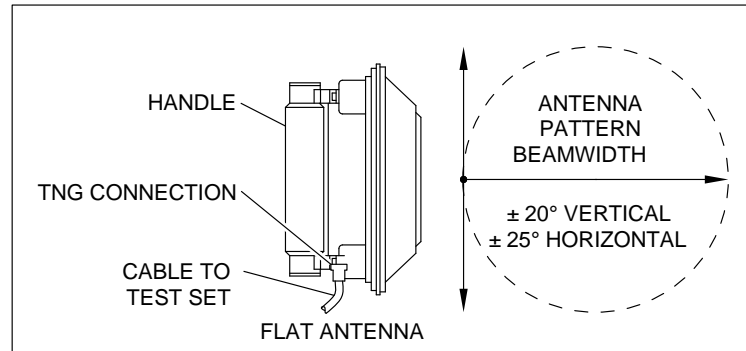

5081043A

Transponder - Adjustment/Test
Figure 502 (Sheet 1 of 1)

ADS-B - ADJUSTMENT/TEST

AMM-34-50-21-071-801

1. General

A. This task gives procedures to do the adjustment/test of the ADS-B.

NOTE: ADS-B test is only required, if the ADS-B function is enabled.

- There are two testing setup methods, the preferred method is with the use of a transponder antenna coupler to limit emissions that may interfere with Air Traffic Control operations and the second method which uses the IFR-6000 antennas.

2. Equipment and Materials

A. Special Tools and Equipment

| Name and Part Number |
|--|
| Transponder Test Set (Aeroflex, IFR6000) or equivalent |
| UC-584 Universal Transponder Antenna Coupler Dual Antenna Kit (Viavi 112349)[1] |
| Weight-on-Wheels (WOW) Box (EAI, 87-117390-1001) or AMC 2.4.01 (or higher). |
| Ground Power Unit (GPU). AllStar 450 or AllStar G.S.E. or Hobart GPU-400 or Hobart GPU-600 or Bycan PS-28100 |

[1] For test with UC-584 antenna coupler.

3. Job Set-Up with UC-584 Antenna Couplers

SUBTASK AMM-34-50-21-071-921-001-A

- A. Make aircraft safe for maintenance. Refer to [AMM-20-00-01-051-801 – Make Safe For Maintenance](#).
- B. If on jacks, refer to [AMM-07-10-00-051-801 – Jacking - Maintenance Practices](#) and [AMM-08-20-00-051-801 – Leveling](#).
- C. Connect external power. Refer to [AMM-24-40-00-051-801 – External Power - Maintenance Practices](#). Do not turn on START BATT and SYS BATT switches until prompted.
- D. Prepare Anti-ice system for maintenance. Refer to [AMM-20-00-03-051-801 – Prepare Anti-Ice Systems For Maintenance](#).
- E. Connect Antenna Coupler UC-584S to Aircraft upper Transponder Antenna as follows: (as applicable)

NOTE: For Transponder–1 Adjustment/Test

- (1) Place Antenna Coupler (2) over the antenna (3), guiding antenna in to the slot on the bottom of the coupler.
- (2) Lock Antenna Coupler (2) into place by pushing lever on the side of the coupler into a down and locked position.

NOTE: Coupler must be tightly pressed and locked in place for Test Set to function correctly. Coupler will lock into place when the black rubber gasket is not completely depressed against the aircraft, but the Test Set will not measure functions accurately.

CAUTION: DO NOT CONNECT COAX CABLE TO IFR-6000 ANT PORT. DAMAGE TO EQUIPMENT WILL OCCUR.

- (3) Connect long RF coaxial cable (1) between the Antenna Coupler (2) and Test Set RF I/O Connector.

CAUTION: THE RF COAXIAL CABLE CAN BE A TRIPPING HAZARD. MAKE SURE TO SECURE THE CABLE. PERSONAL INJURY AND DAMAGE TO THE ANTENNAS AND TEST EQUIPMENT COULD OCCUR.

- (4) Temporarily secure the coaxial cable to the aircraft with tape. Tape can be removed after the test is completed.
- (5) Push Antenna Coupler (2) firmly against the aircraft skin until the black rubber gasket on the rim of the coupler is completely depressed tightly against the aircraft.
- F. Connect Antenna Coupler UC-584 to Aircraft lower Transponder Antenna as follows: (as applicable)

NOTE: For Transponder–2 Adjustment/Test

- (1) Place Antenna Coupler (2) over the antenna (4), guiding antenna in to the slot on the bottom of the coupler.

-
- (2) Lock Antenna Coupler (2) into place by pushing lever on the side of the coupler into a down and locked position.
- NOTE:** Antenna Coupler must be tightly pressed and locked in place for Test Set to function correctly. Coupler will lock into place when the black rubber gasket is not completely depressed against the aircraft, but the Test Set will not measure functions accurately.
- CAUTION:** DO NOT CONNECT COAX CABLE TO IFR-6000 ANT PORT. DAMAGE TO EQUIPMENT WILL OCCUR.
- (3) Connect long RF coaxial cable (1) between the Antenna Coupler and Test Set RF I/O Connector.
- CAUTION:** THE RF COAXIAL CABLE CAN BE A TRIPPING HAZARD. MAKE SURE TO SECURE THE CABLE. PERSONAL INJURY AND DAMAGE TO THE ANTENNAS AND TEST EQUIPMENT COULD OCCUR.
- (4) Temporarily secure the coaxial cable to the aircraft with tape. Tape can be removed after the test is completed.
- (5) Push Antenna Coupler (2) firmly against the aircraft skin until the black rubber gasket on the rim of the coupler is completely depressed tightly against the aircraft.
- G. Connect Weight On Wheels (WOW) box or Aircraft Maintenance Computer (AMC) and set switches on Box to W-On-W (on-ground). Refer to [AMM-20-00-04-051-801 – Weight On Wheels \(WOW\) Box - Connect/Disconnect](#).

4. Job Set-Up with IFR-6000 Antenna

SUBTASK AMM-34-50-21-071-921-001

- A. Make aircraft safe for maintenance. Refer to [AMM-20-00-01-051-801 – Make Safe For Maintenance](#).
- B. If on jacks, refer to [AMM-07-10-00-051-801 – Jacking - Maintenance Practices](#) and [AMM-08-20-00-051-801 – Leveling](#).
- C. Connect external power. Refer to [AMM-24-40-00-051-801 – External Power - Maintenance Practices](#). Do not turn on START BATT and SYS BATT switches until prompted.
- D. Prepare Anti-ice system for maintenance. Refer to [AMM-20-00-03-051-801 – Prepare Anti-Ice Systems For Maintenance](#).
- E. Take proper safety precautions to protect personnel. Position aircraft such that multi-path RF reflections between the IFR-6000 test set, the aircraft's antennas, and surrounding objects are minimized. The area on the left side of the aircraft should not be up against a metal wall or another aircraft. If necessary, position the aircraft outside, away from metal buildings or other aircraft. Refer to [Fig. 502](#).

CAUTION: FAILURE TO COMPLY WITH THIS STEP AND CONTINUING WITH THIS PROCEDURE COULD IMPACT LOCAL AIRPORT TOWER OPERATIONS.

- F. If applicable, contact local airport tower to inform them a transponder test is being run at your location (inside or outside). Request appropriate squawk and allotted time to run test.

NOTE: If local airport tower is not informed, use code 1200.

- G. Attach test set antenna to Transponder Test Set using 1 foot long test set cable (blue cable, supplied if IFR6000 is used), connected to ANT port on tester.
- H. During testing, place the Transponder Test Set antenna approximately two feet to four feet forward and in line with right wing tip tank. May require periodic repositioning between two and four feet.
- I. Connect Weight On Wheels (WOW) box or Aircraft Maintenance Computer (AMC) and set switches on Box to W-On-W (on-ground). Refer to [AMM-20-00-04-051-801 – Weight On Wheels \(WOW\) Box - Connect/Disconnect](#).

5. **ADS-B System Test**

SUBTASK AMM-34-50-21-071-701-002

- A. In order to verify ADS-B OUT function is active, perform the following test using IFR 6000 or an equivalent test set.

NOTE: If IFR 6000 (or an equivalent transponder test set) does not include the ADS-B test capability, at a minimum, verification that the DF17 extended squitter format is being detected is sufficient. During Generic Mode S tests, DF17 format availability is being checked in the following subtasks:

- [SUBTASK AMM-34-50-20-071-701-001-A](#) or [SUBTASK AMM-34-50-20-071-701-001-B](#)
- [SUBTASK AMM-34-50-20-071-701-002-A](#) or [SUBTASK AMM-34-50-20-071-701-002-B](#)
- [SUBTASK AMM-34-50-20-071-701-003-A](#) or [SUBTASK AMM-34-50-20-071-701-003-B](#)
- [SUBTASK AMM-34-50-20-071-701-004-A](#) or [SUBTASK AMM-34-50-20-071-701-004-B](#)

NOTE: If no transponder test set with the ADS-B test capability is available, as an additional or alternate method of verifying proper operation and performance of the installed ADS-B OUT function, the FAA Public ADS-B Performance Report (PAPR) may be requested after a Return to Service (RTS) flight. This report request may be made online on the FAA web site at the ADS-B related area.

NOTE: To check if IFR 6000 has the ADS-B test, press SETUP to display SETUP-GENERAL page. Press INFO and verify that ADSB is listed in the OPTIONS area.

If using IFR 6000 with the ADSB test option, to make sure that the ADS-B OUT function is active, perform the following procedure:

(1) ADS-B Test Setup

- (a) After the Transponder Test Set (IFR 6000) performs Self Test, push SETUP button on the test set to bring up the SETUP-XPDR page. If necessary, continue pressing SETUP button until SETUP XPDR screen is displayed.
- (b) Press ADS-B SETUP Soft Key to display the SETUP-ADSB Setup Screen. Use NEXT PARAM and PREV PARAM Soft Keys to select each parameter. Configure the setup parameters as shown in the following example:
POS DECODE: GLOBAL
LAT: 35 02 13.80 N
LON: 106 37 1.80 W
BARO PRES ALT: 5450 ft.

ADSB MON: DF17

NOTE: LAT and LON must be set to the values corresponding to the location of the test as shown on the MFD GPS Status Page. In this example, for the test set entry, the position data corresponds to the MFD displayed position data of N35°02.23' W106°37.03', where seconds are represented as a fraction of a minute, and, therefore, the entered seconds' values are $0.23 \times 60 \text{ sec} = 13.80 \text{ sec}$ and $0.03 \times 60 \text{ sec} = 1.80 \text{ sec}$, respectively. BARO PRES ALT is a test reference and must be set to the value corresponding to the tested aircraft Pressure Altitude. Therefore, using the Autopilot Control Panel (ACP) controls, set Baro Correction to 29.92 inHg, and then enter the altitude value displayed on the PFD into BARO PRES ALT entry field of IFR 6000. This entry may not be available in some IFR 6000 test sets.

(2) ADS-B OUT Data Monitor Test

- (a) Make sure aircraft power is off.
- (b) Set WOW Box switches to W-on-W (on-ground).
- (c) On IFR 6000, press XPDR mode Key until ADSB/GICB/UAT MAIN menu is displayed. Press the ADS-B MON Soft Key to display the ADS-B MON list screen.
- (d) Power up the aircraft.
- (e) On the PFD, select active transponder and enter transponder test squawk code as 1200 (or if using the Job Set-Up with IFR-6000 Antenna – as assigned by the Air Traffic Control).
- (f) Make sure that the Baro Correction is set to 29.92 inHg.
- (g) Set WOW Box switches to W-off-W (airborne). Transponder should be in ALT mode.
- (h) On IFR 6000, press Run Test to execute ADS-B MON Test
- (i) Select BDS 0,5 AIRBORNE POS and check the following data:
AA = matches aircraft ICAO code displayed on the MFD Settings Page
LAT = comparable to the aircraft latitude.
LON = comparable to the aircraft longitude.
BARO PRES ALT = matches aircraft altitude displayed on the L PFD within 125 ft.
- (j) Set WOW Box switches to W-on-W (on-ground).

6. Job Close-Up

SUBTASK AMM-34-50-21-071-921-003

- A. Reset the collared ECB's. Refer to AMM-20-00-03-051-801 – Prepare Anti-Ice Systems For Maintenance.
- B. Scroll to FLCS using outer knob. Press inner knob to select. Scroll to the listed ECB using outer knob and highlight. Push “RESET” Soft key. Press “CONFIRM RESET” soft key.
 - ECB - NOSE LDG GEAR (L AFT Bus)
 - ECB - L MAIN LDG GEAR (L AFT Bus)
 - ECB - R MAIN LDG GEAR (L AFT Bus)
- C. Scroll to ENGINE using outer knob. Press inner knob to select. Scroll to the listed ECB using outer knob and highlight. Push “RESET” Soft key. Press “CONFIRM RESET” soft key.
 - ECB - L ENG FIRE EXTNGR (L FWD Bus)
 - ECB - R ENG FIRE EXTNGR (R FWD Bus)
- D. Power down the aircraft by setting the SYS BATT and START BATT switches to OFF and the BUS TIE to OPEN.
- E. Disconnect WOW Box from aircraft. Refer to AMM-20-00-04-051-801 – Weight On Wheels (WOW) Box - Connect/Disconnect.
- F. If on jacks, lower aircraft and remove jacks. Refer to [AMM-07-10-00-051-801 – Jacking - Maintenance Practices](#).
- G. If applicable, call the local control tower and tell them the transponder test is complete.
- H. Remove all tools, equipment and unwanted material from work area.
- I. Disconnect external power. Refer to [AMM-24-40-00-051-801 – External Power - Maintenance Practices](#).
- J. If all other maintenance is complete, return aircraft to service. Refer to [AMM-20-00-02-051-801 – Return To Service \(After Maintenance\)](#).

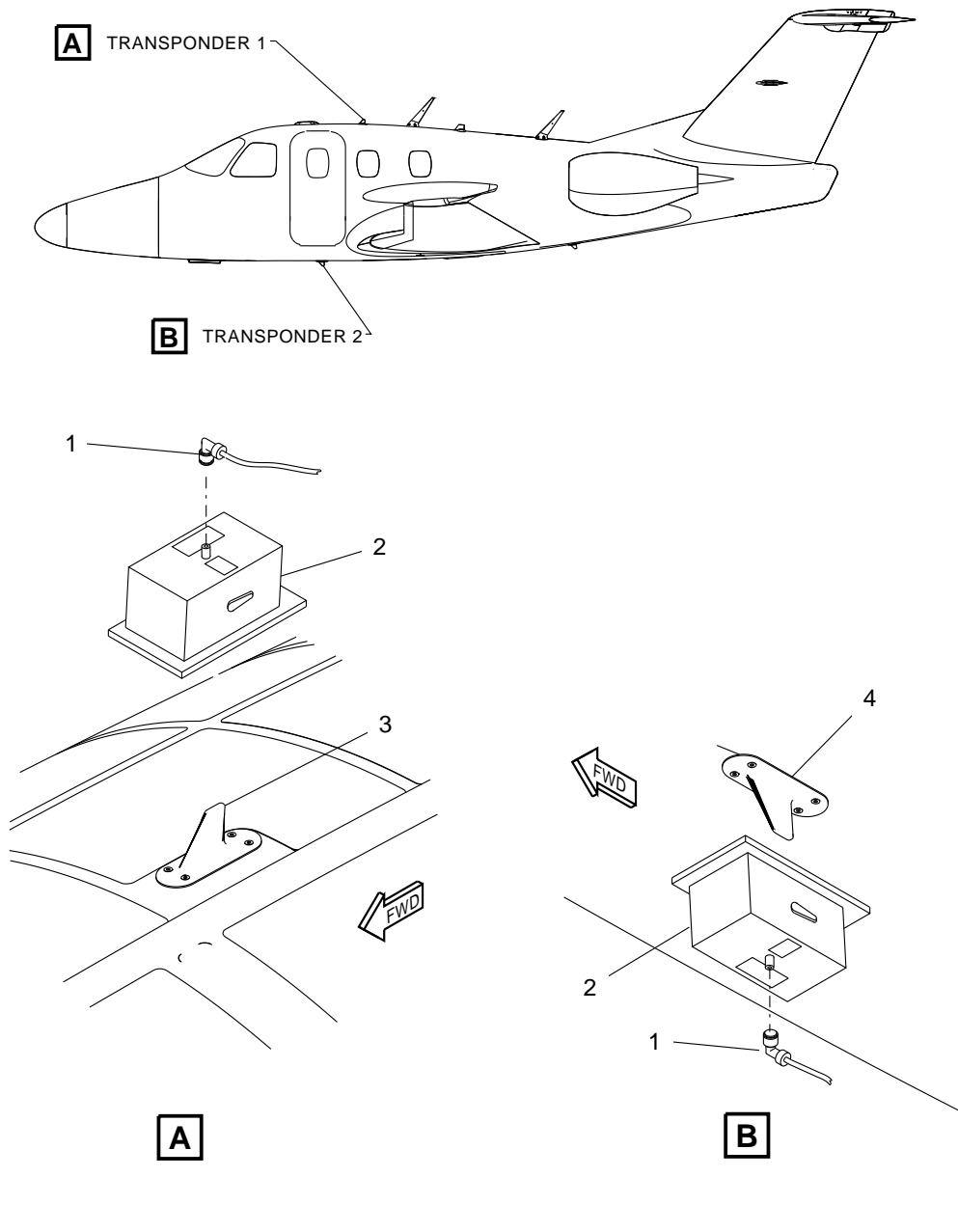

**Transponder - Adjustment/Test
Figure 501 (Sheet 1 of 1)**

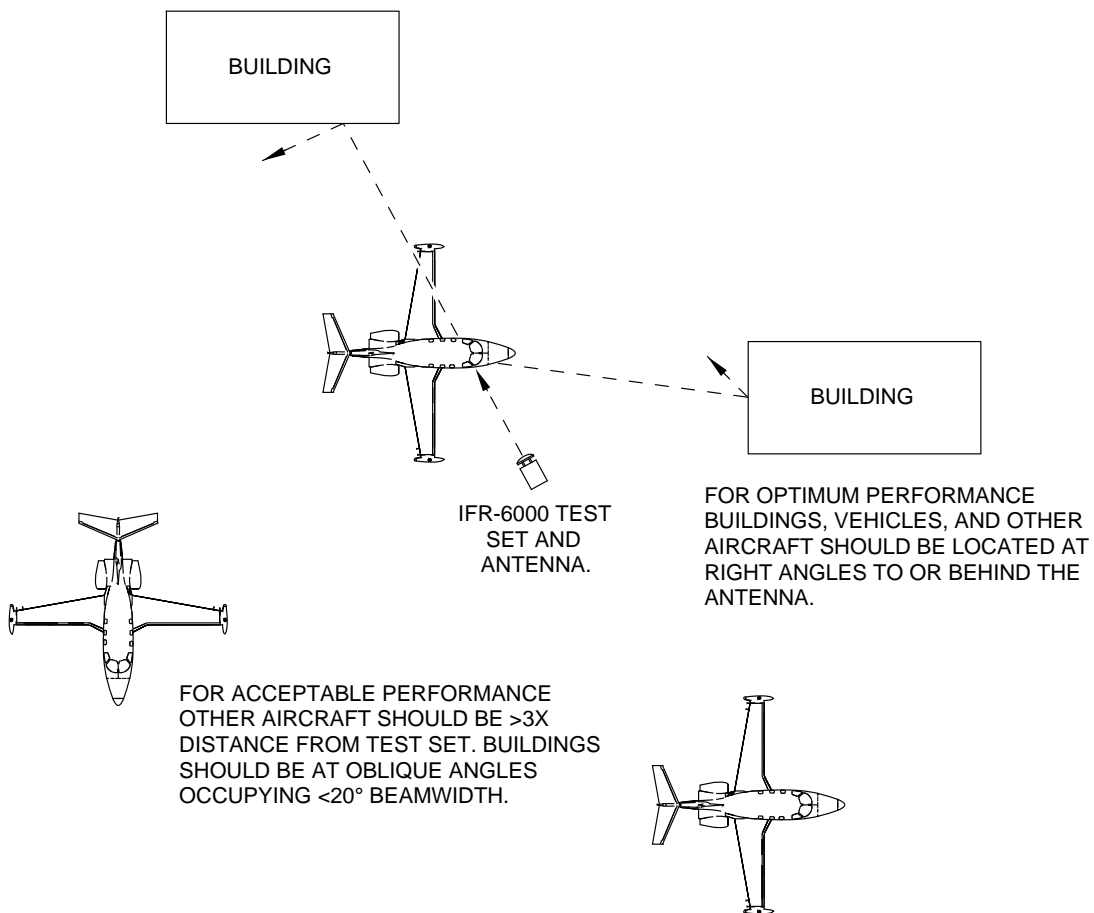
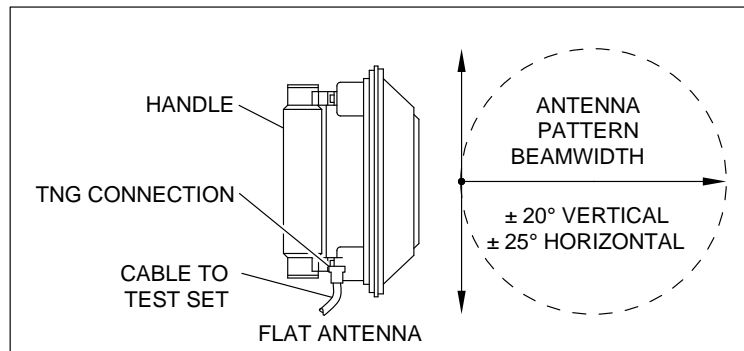

5081043A

ADS-B - Adjustment/Test
Figure 502 (Sheet 1 of 1)

THIS PAGE INTENTIONALLY LEFT BLANK

TRANSPONDER ANTENNA RELAY - INSTALLATION

AMM-34-50-23-041-801

1. General

- A. This task gives the procedures to install the transponder antenna relay(s).
 - (1) Dual Diversity Transponder Configuration
 - (a) There are two transponder (upper and lower) antenna relays installed with the optional Dual Diversity Transponder configuration behind the instrument panel.

2. Job Set-Up

SUBTASK AMM-34-50-23-041-921-001

- A. Make sure the aircraft is in the same configuration as it was when the removal task was completed. Refer to [AMM-34-50-23-001-801 – Transponder Antenna Relay - Removal](#).

3. Procedure

SUBTASK AMM-34-50-23-041-411-001

(Refer to [Fig. 401](#). Installation procedures apply to both sides)

NOTE: The lower antenna relay and upper antenna relay are located inboard of their respective diversity transponder(s).

- A. Remove the protective caps from the electrical connectors.
- B. Put the transponder lower and/or upper antenna relay (1) on the structure and align the holes.
- C. Attach the transponder lower and/or upper antenna relay (1) with the two screws (3) and washers (2).
- D. Connect the coax cable connectors 23K02P01 to the transponder lower antenna relay coax receptacle marked COM (Common) (5).
- E. Connect the coax cable connectors 23K03P01 to the transponder upper antenna relay coax receptacle marked COM (Common) (5).
- F. Connect the coax cable connectors 23K02P02 to the transponder lower antenna relay coax receptacle marked NC (Normally Closed) (6).
- G. Connect the coax cable connectors 23K03P02 to the transponder upper antenna relay coax receptacle marked NC (Normally Closed) (6).
- H. Connect the coax cable connectors 23K02P03 to the transponder lower antenna relay coax receptacle marked NO (Normally Open) (4).
- I. Connect the coax cable connectors 23K03P03 to the transponder upper antenna relay coax receptacle marked NO (Normally Open) (4).

- J. Connect the electrical connector 23K02P04 to the transponder lower antenna relay electrical receptacle (7).
- K. Connect the electrical connector 23K03P04 to the transponder upper antenna relay electrical receptacle (7).
- L. Electrically bond the transponder lower antenna relay (1) to the structure. Refer to [AMM-20-03-00-051-801 – Electrical Bonding - Maintenance Practices](#). Resistance must be 2.5 milliohms or less.

4. **Job Close-Up**

SUBTASK AMM-34-50-23-041-921-002

- A. Remove all tools, equipment, and unwanted material from the work area.
- B. If removed, install the air conditioning ducts. Refer to [AMM-21-20-11-041-801 – Cockpit Ducting - Installation](#).
- C. Install the 222 KZ - Multi Function Display (MFD). Refer to [AMM-31-10-15-041-801 – Multi-Function Display - Installation](#).
- D. Remove the warning placards.
- E. Do the adjustment/test of the transponder system. Noting effectivity, refer to [AMM-34-50-20-071-801 – Transponder - Adjustment/Test](#)
- F. If all other maintenance is complete, return the aircraft to service. Refer to [AMM-20-00-02-051-801 – Return To Service \(After Maintenance\)](#).

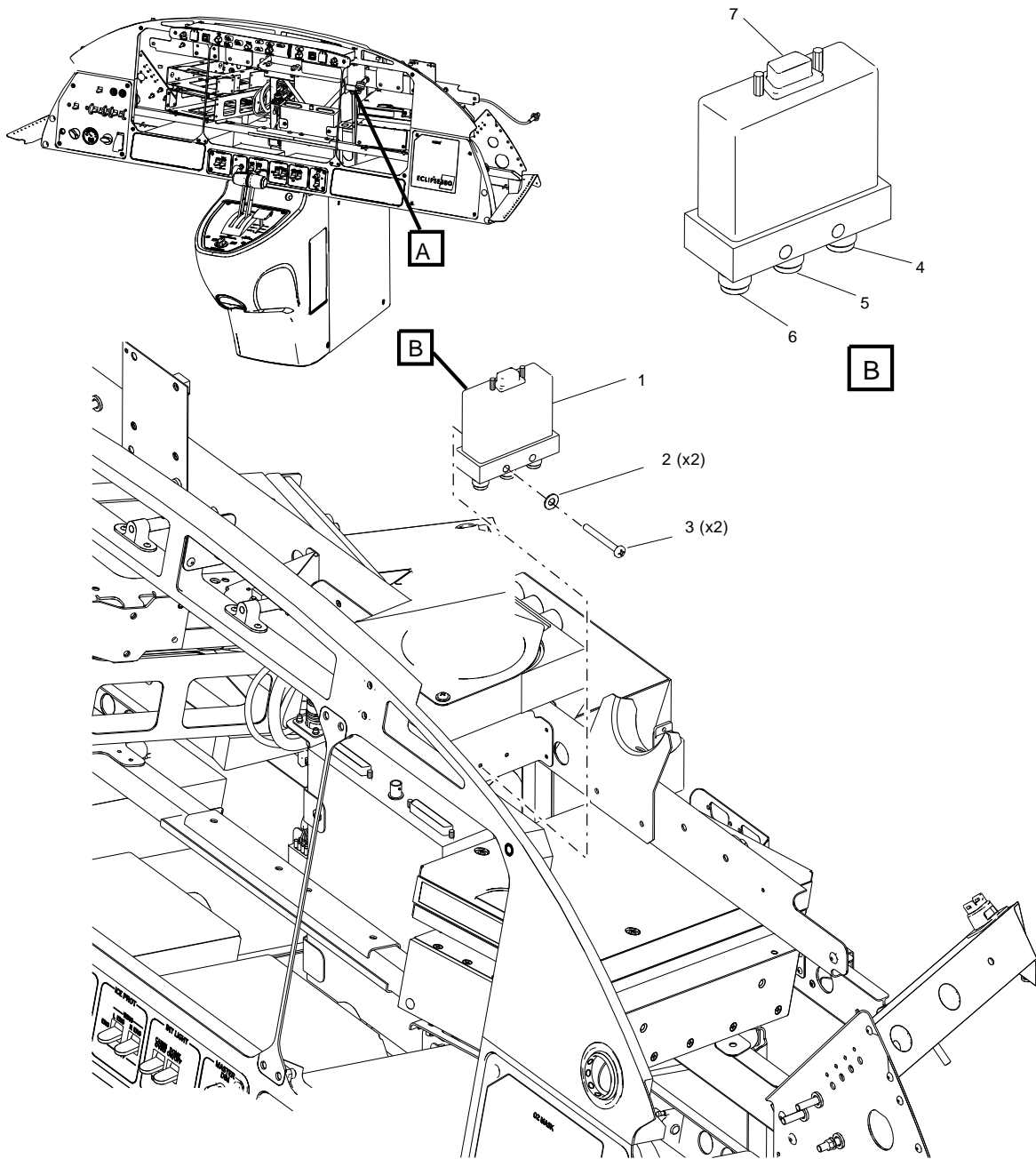

NOTE:
STRUCTURE AND EQUIPMENT
REMOVED FOR CLARITY

A

508077B

Transponder Antenna Relay - Removal/Installation
Figure 401 (Sheet 1 of 1)

THIS PAGE INTENTIONALLY LEFT BLANK

TRANSPONDER COOLING - ADJUSTMENT/TEST

AMM-34-50-24-071-801

1. General

- A. This task gives procedures to test the transponder cooling system.

2. Job Set-Up

SUBTASK AMM-34-50-24-071-921-001

- A. Make the aircraft safe for maintenance. Refer to [AMM-20-00-01-051-801 – Make Safe For Maintenance](#).
- B. The mechanical circuit breakers for this procedure are located on the left instrument panel and the pilots and copilots communications jacks panel. Refer to [Fig. 501, Sheet 1](#) and [Fig. 502, Sheet 1](#).

3. Test Procedure

SUBTASK AMM-34-50-24-071-781-001

- A. Make sure the following are pushed in:
- MECHANICAL CIRCUIT BREAKER - INSTRUMENT PANEL, LEFT: L PFD CNS 1. Refer to [Fig. 501, Sheet 1](#).
 - MECHANICAL CIRCUIT BREAKER - CIRCUIT BREAKER BOX LEFT, XPDR1/KYBD1). Refer to [\(4\)](#).
 - MECHANICAL CIRCUIT BREAKER - CIRCUIT BREAKER BOX RIGHT: XPDR2/KYBD2). Refer to [\(5\)](#).
- B. Power up the aircraft by setting the SYS BATT and START BATT switches to ON and the BUS TIE switch to AUTO. Clear any MASTER WARNINGS/CAUTIONS as needed.
- C. On the Multi-Function Display (MFD) ECB page, make sure that the ECB - L PFD, COM/NAV 1, ACP (R FWD Bus) is set to AUTO/ON.
- D. Make sure that CAS message - ADVISORY: AVIONICS COOLING FAIL is not displayed on the MFD.
- E. Check that the avionics cooling blower is running.
- NOTE:** The avionics cooling blower operation can be checked for air flow from the glare shield openings.
- F. Pull the MECHANICAL CIRCUIT BREAKER - CIRCUIT BREAKER BOX LEFT, XPDR1/KYBD1 and MECHANICAL CIRCUIT BREAKER - CIRCUIT BREAKER BOX RIGHT: XPDR2/KYBD2). Refer to [\(5\)](#).
- Make sure that the avionics cooling blower is not running.
- G. Push in the MECHANICAL CIRCUIT BREAKER - CIRCUIT BREAKER BOX LEFT, XPDR1/KYBD1). Refer to [\(4\)](#).

EFFECTIVITY: ALL

34-50-24

- Make sure that the avionics cooling blower is running.
 - Make sure that the CAS message - ADVISORY: AVIONICS COOLING FAIL is not displayed on the MFD.
- H. Push in the MECHANICAL CIRCUIT BREAKER - CIRCUIT BREAKER BOX RIGHT: XPDR2/KYBD2). Refer to (5) .
- I. Pull the MECHANICAL CIRCUIT BREAKER - CIRCUIT BREAKER BOX LEFT, XPDR1/KYBD1). Refer to (4) .
- Make sure that the avionics cooling blower is running.
 - Make sure that the CAS message - ADVISORY: AVIONICS COOLING FAIL is not displayed on the MFD.
- J. Push in the MECHANICAL CIRCUIT BREAKER - CIRCUIT BREAKER BOX LEFT, XPDR1/KYBD1. Refer to (4) .
- Make sure that the avionics cooling blower is running.
 - Make sure that the CAS message - ADVISORY: AVIONICS COOLING FAIL is not displayed on the MFD.
- K. Power down aircraft by setting the SYS BATT and START BATT switches to the OFF position and the BUS TIE switch to the OPEN position.

4. **Job Close-Up**

SUBTASK AMM-34-50-24-071-921-002

- A. Remove all tools, equipment, and unwanted material from the work area.
- B. If all other maintenance is complete, return the aircraft to service. Refer to [AMM-20-00-02-051-801 – Return To Service \(After Maintenance\)](#).

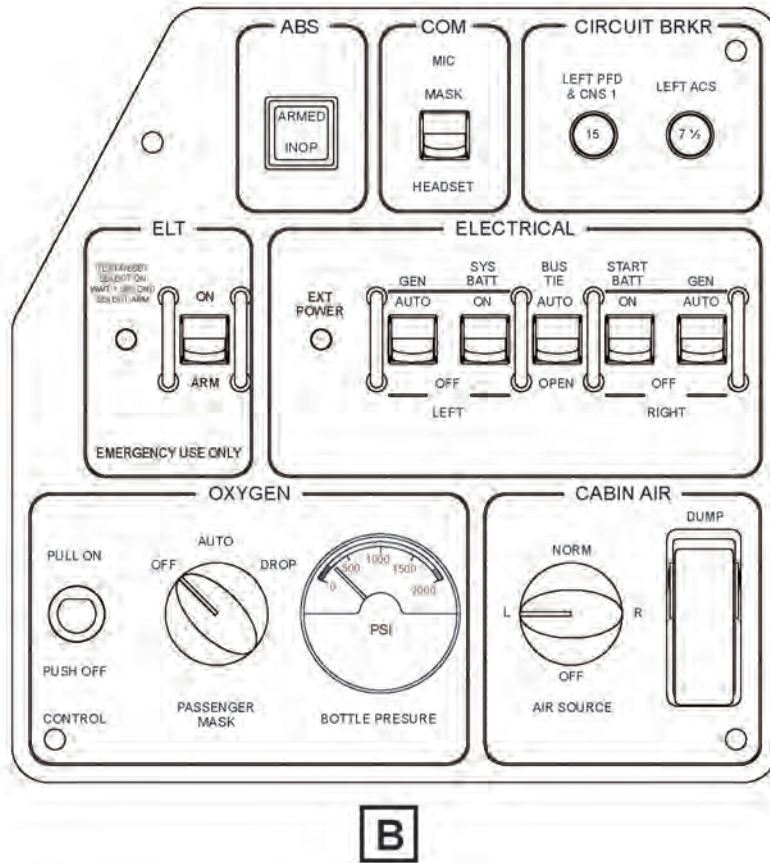
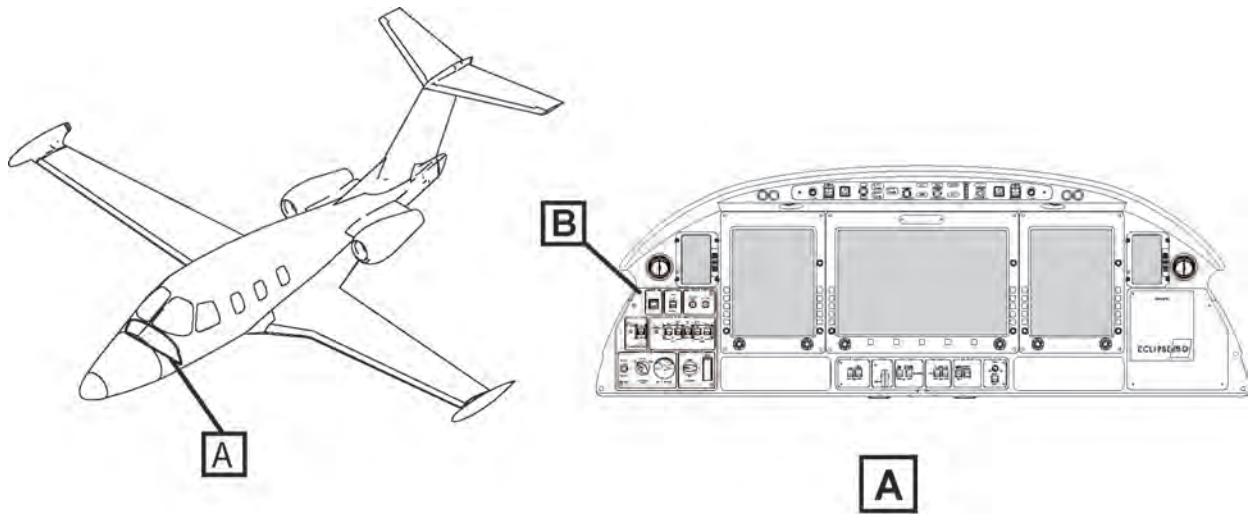

Instrument Panel - Left
Figure 501 (Sheet 1 of 1)

5A21060866SBDM

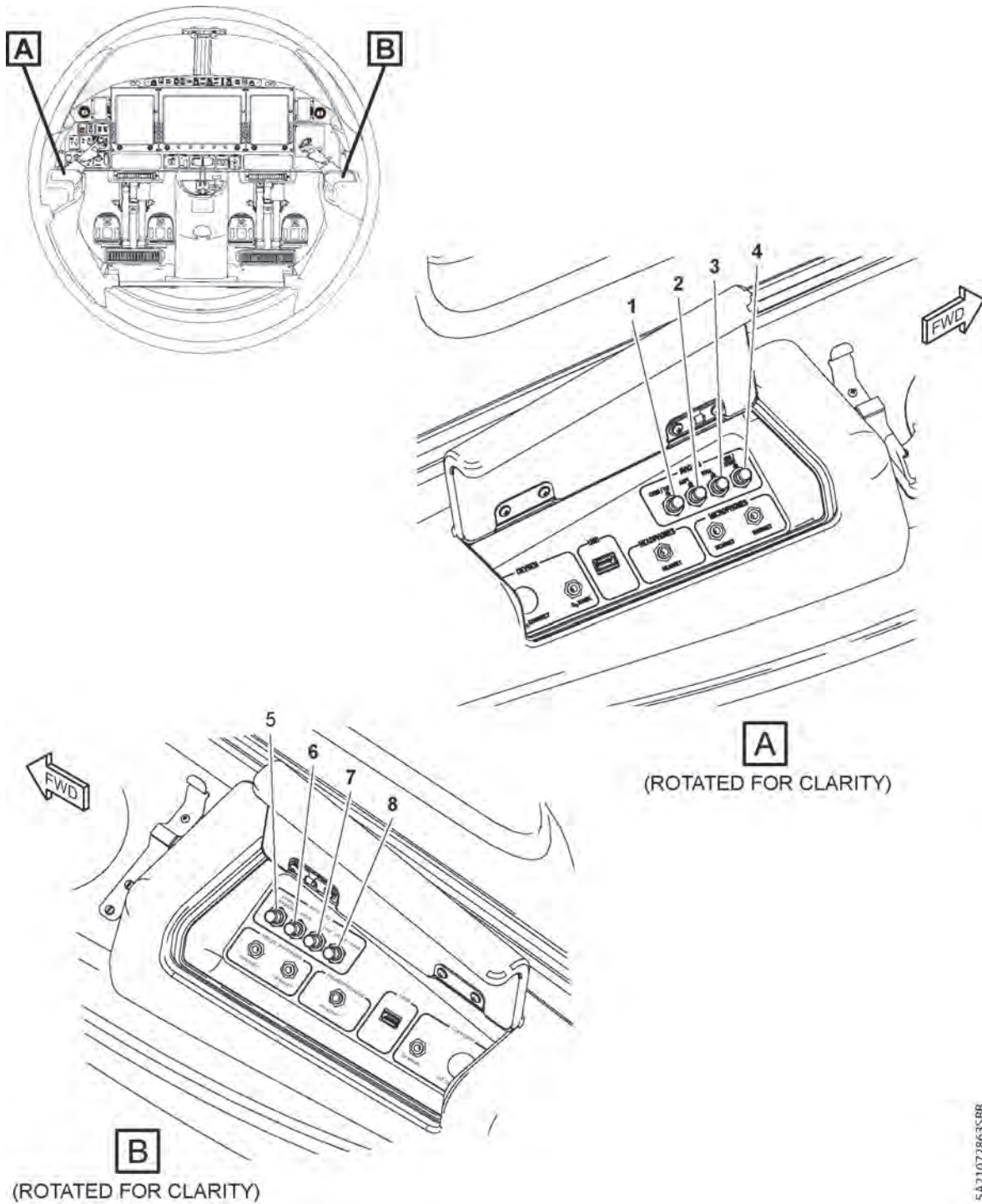

**Circuit Breaker Locations
Figure 502 (Sheet 1 of 1)**

5A21072863588