CHAPTER - 34 HIGHLIGHTS
(Summary of Changes)*Revision No. TR34-6 Sep 12/17*

TO: HOLDERS OF THE AIRCRAFT MAINTENANCE MANUAL (06-123838)

Pages that have been added or revised are summarized below. Remove and insert the affected pages as listed, and enter the above revision number with issue date into the Record of Revisions sheet.

This Temporary Revision incorporates and supersedes previously released temporary revisions for the chapters listed below.

Do not remove this page. Keep it in place as a record of previous changes.

CH/SE/SU Page Block No.	Description of Change
34-10-10 PgBlk 401-Rem (C)	Added auxiliary heaters to Pitot/AOA Probe - Removal - Config C.
34-10-10 PgBlk 401-Inst (C)	Added auxiliary heaters to Pitot/AOA Probe - Installation - Config C.

THIS PAGE INTENTIONALLY LEFT BLANK

PITOT/AOA PROBES - REMOVAL

AMM-34-10-10-001-C-801

1. General

- A. This task gives the procedures to remove the Pitot/Angle of Attack (AOA) probes.
- B. There are two Pitot/AOA probes on the fuselage, forward of the cockpit. Access procedures for the right Pitot/AOA probe are given in Job Setup.

NOTE: In the event the grounding jumper needs to be replaced, the entire probe must be removed.

NOTE: In the event that the auxiliary heater needs to be replaced, the entire probe must be removed.

2. Job Set-Up

SUBTASK AMM-34-10-10-001-C-921-001

- A. Make aircraft safe for maintenance. Refer to [AMM-20-00-01-051-801 – Make Safe For Maintenance](#).
- B. To gain access to remove the left Pitot/AOA probe remove the access panel that follows:
 - 211 CT - Nose Access Panel
- C. To gain access to remove the right Pitot/AOA, use the Air Conditioning controls to open the VCS doors, as follows:
 - (1) On the MFD ENVIR page, establish the following conditions:
 - AIR COND: AUTO
 - AFT Fan: AUTO
 - FWD Fan: AUTO
 - Cockpit Temp: MAX COOL
 - Cabin Temp: MAX COOL
 - (2) Make sure the Forward and Aft VCS doors have fully opened. Refer to [AMM-21-00-00-071-801 – Air Conditioning - Adjustment/Test](#), Fig. 506 (Sheet 1).
- D. Remove power from the aircraft.

CAUTION: AFT VCS DOOR MUST BE DISABLED TO PREVENT PERSONAL INJURY AND DAMAGE TO EQUIPMENT IF AIRCRAFT POWER IS INADVERTENTLY APPLIED.

- (1) Once electrical power is removed, disconnect the electrical connector on the aft VCS door actuator.

3. Procedure

SUBTASK AMM-34-10-10-001-C-011-001

(Refer to [Fig. 401](#).)

- A. Disconnect electrical connector (17) from aircraft wiring harness.
 - B. Remove jam nut (15) from electrical connector (17) and remove electrical connector from bracket (16) by removing .
 - C. Disconnect electrical connector (2) from Pitot/AOA probe (4) .
 - D. Disconnect Pitot tube assembly (3) from Pitot/AOA probe (4) .
 - E. Disconnect Pitot/AOA Auxiliary Heater electrical connector (17) from aircraft harness.
 - F. Remove jam nut (15) from Pitot/AOA Auxiliary Heater electrical connector (17) and remove connector (17) from bracket (16) .
 - G. For the LH Pitot/AOA probe ([Fig. 401, Sheet 2](#)), remove the self locking nut (8) , lock washer (9) , flat washer (10) , grounding jumper (7) , and the hex head screw (11) from hole (12) in the aircraft structure.
 - H. For the RH Pitot/AOA probe ([Fig. 401, Sheet 3](#)), remove the self locking nut (8) , flat washer (10) , grounding jumper (7) , and the hex head screw (11) from hole (12) in the aircraft structure.
 - I. Remove five screws (5) that attach Pitot/AOA probe (4) to structure (1) .
 - J. Remove Pitot/AOA probe (4) with grounding jumper (7) attached and gasket (6) from aircraft.
- NOTE:** Do not remove grounding jumper from probe unless it needs to be replaced.
- K. If required for the LH Pitot/AOA probe ([Fig. 401, Sheet 2](#)), remove the screw (14) , washer (13) , and grounding jumper (7) from the Pitot/AOA probe (4) .
 - L. If required for the RH Pitot/AOA probe ([Fig. 401, Sheet 3](#)), remove the screw (14) , washer (13) , and grounding jumper (7) from the Pitot/AOA probe (4) .

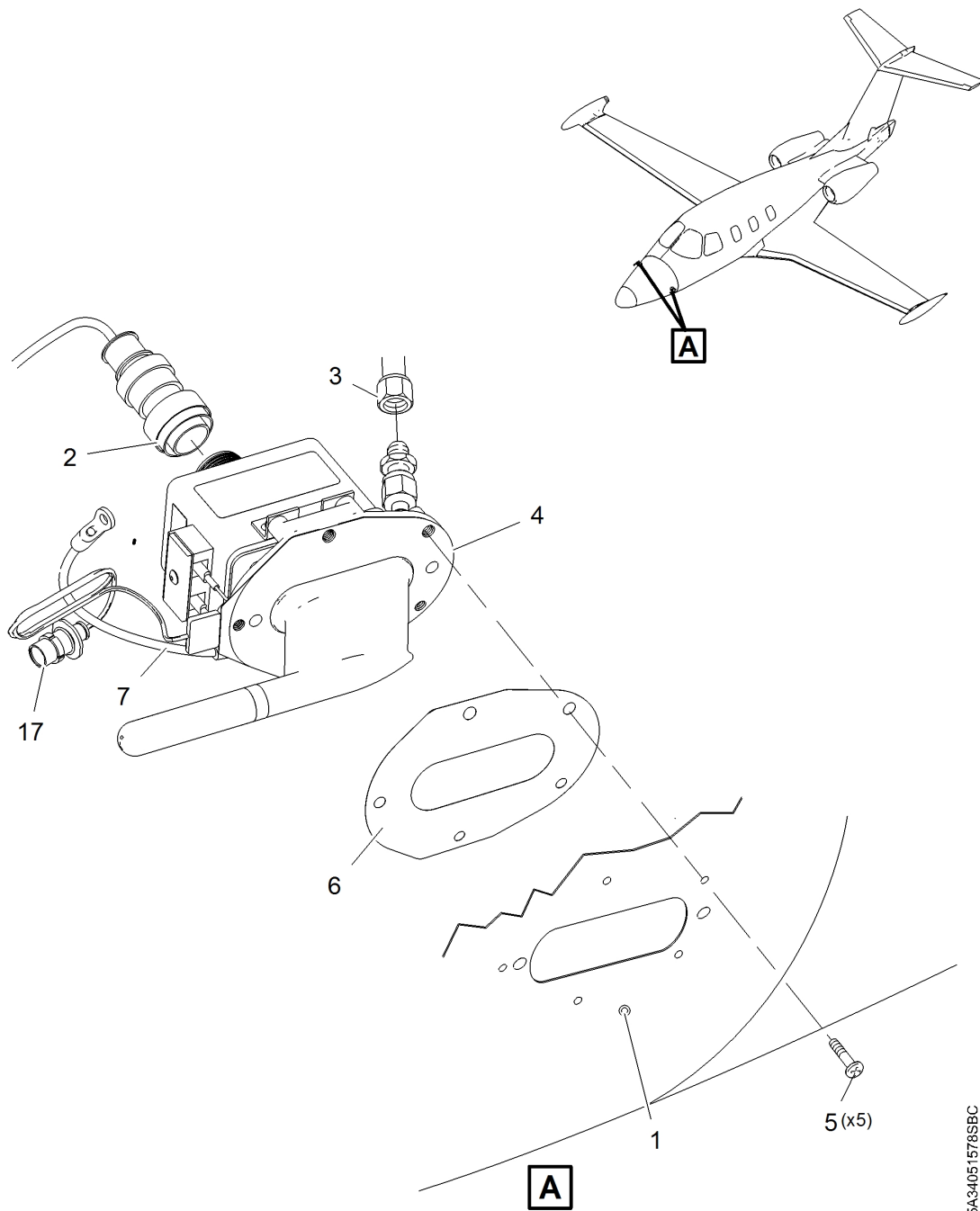

5A34051578SBC

Pitot/AOA Probes - Removal/Installation
Figure 401 (Sheet 1 of 4)

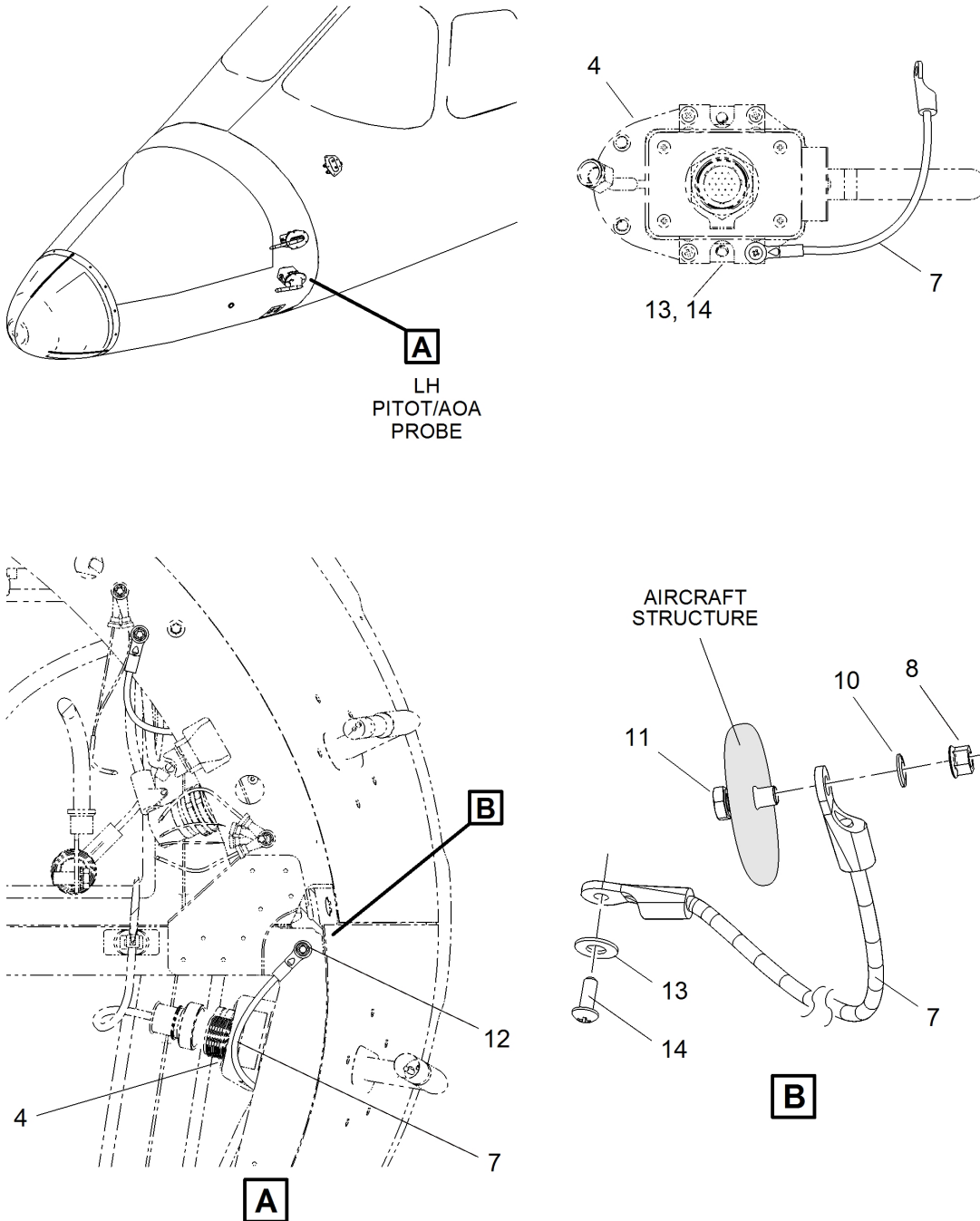

5141820A

Pitot/AOA Probes - Removal/Installation
Figure 401 (Sheet 2 of 4)

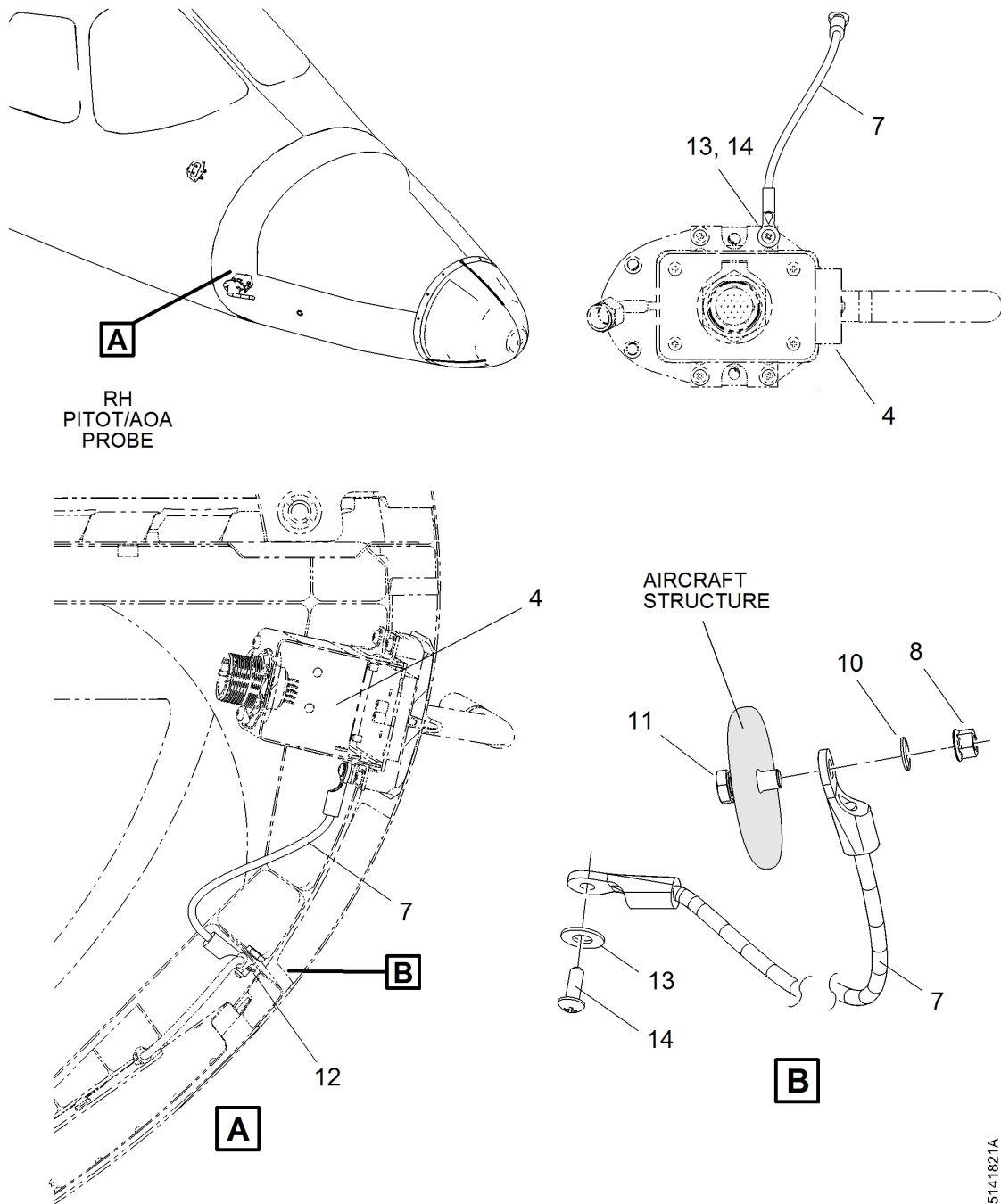

Pitot/AOA Probes - Removal/Installation
Figure 401 (Sheet 3 of 4)

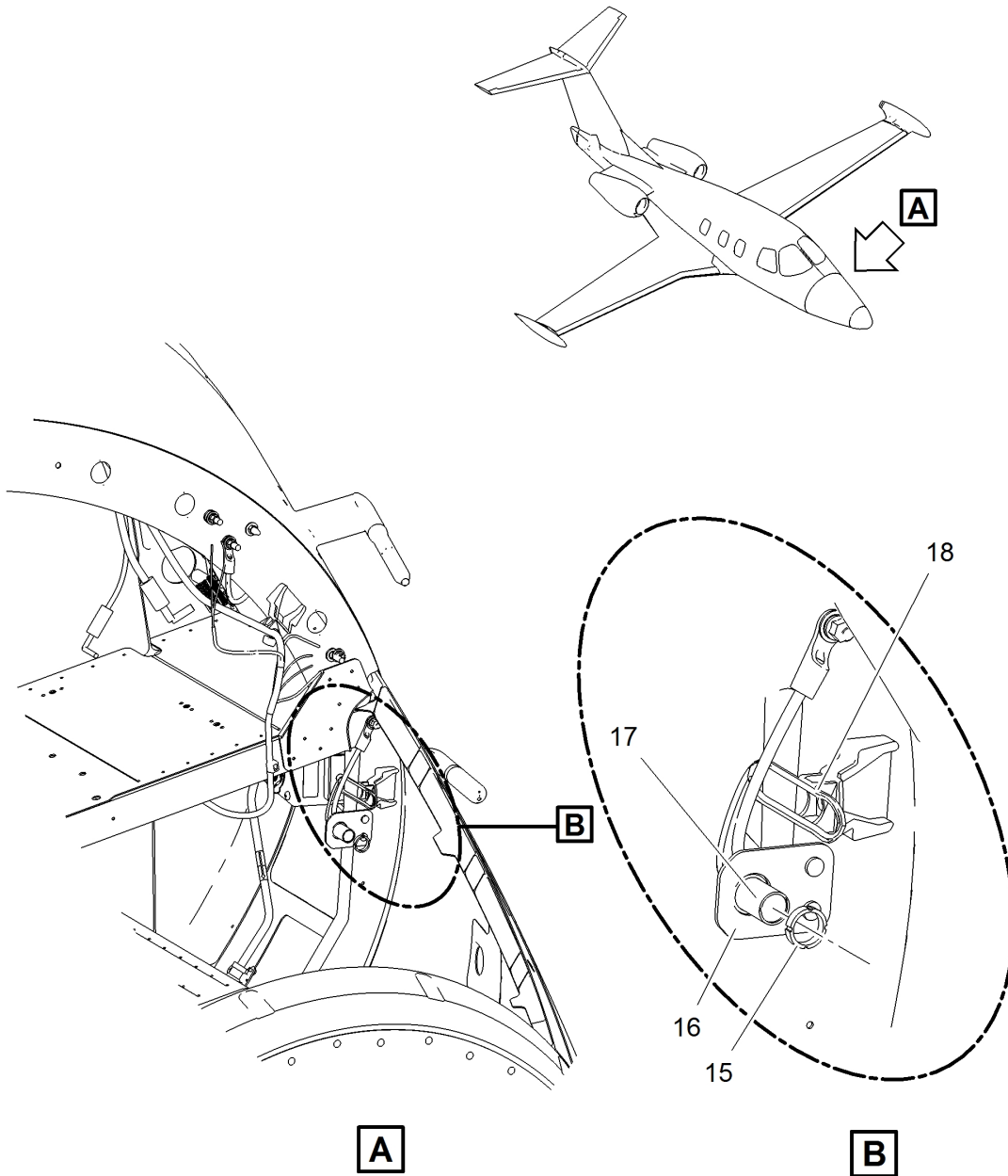

5171943A

Pitot/AOA Probes - Removal/Installation
Figure 401 (Sheet 4 of 4)

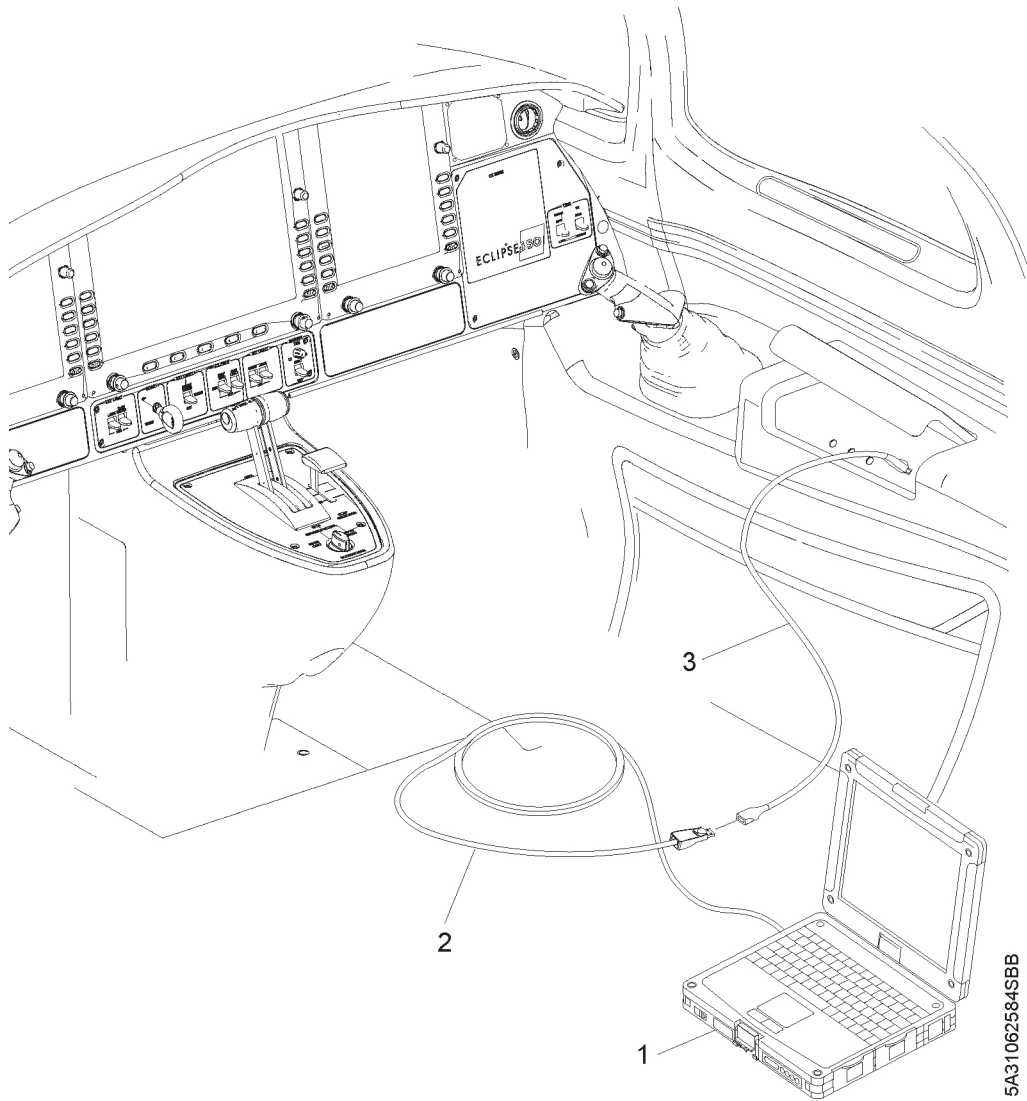

Co-pilot's Armrest USB Port - AMC Hookup
Figure 402 (Sheet 1 of 1)

AVIO MAINTENANCE COMPUTER

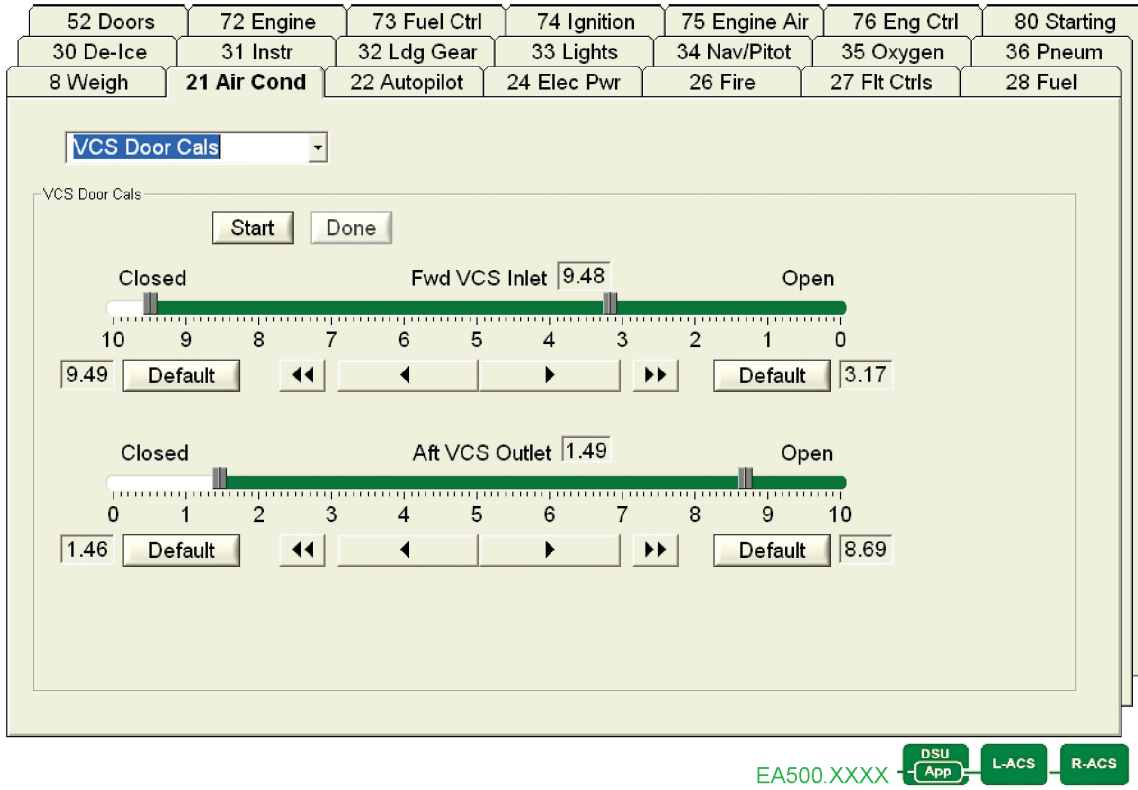

5080708B

VCS Door Cals Page
Figure 403 (Sheet 1 of 1)

PITOT/AOA PROBE - INSTALLATION

AMM-34-10-14-041-C-801

1. General

- A. This task gives the procedures to install the Pitot/Angle of Attack (AOA) probes.

2. Job Set-Up

SUBTASK AMM-34-10-10-041-C-921-001

(Refer to [Fig. 401, Sheet 1.](#))

- A. Make sure aircraft is in the same configuration as it was when the removal task was completed. Refer to [AMM-34-10-10-001-C-801 – Pitot/AOA Probes - Removal](#).
- B. If the Pitot/AOA probe is new, check to see if a packing (support) block (1) is supplied with the unit.

NOTE: New assemblies may be shipped from the manufacturer with a packing block (1) in order to protect the device during shipping, handling and installation.

- (1) It is strongly recommended that new Pitot/AOA probe(s) should be mounted to the aircraft with the packing block (1) still in place in order to prevent pinching and kinking of the main plumbing line (2) and connection (3) during the installation process. It is also recommended that a Pitot cover be used on the Pitot/AOA probe as practical during and after installation in order to provide increased protection against foreign object damage (FOD).

3. Procedure

SUBTASK AMM-34-10-10-041-C-411-001

(Refer to [Fig. 401.](#))

CAUTION: REMOVE THE NOTED SCREW FROM THE PITOT/AOA PROBE ONLY.
DO NOT LOOSEN OR DISTURB OTHER MOUNTING HARDWARE.

NOTE: The fastener securing the grounding jumper to the probe shall be installed using torque required to bring the bearing faces into positive contact and have Loctite 242 to applied to the screw threads.

- A. If required for the LH Pitot/AOA probe ([Fig. 401, Sheet 3](#)), install the grounding jumper (7) to the probe (4) using the existing washer (14) and screw (13) from the previously installed grounding jumper.
- B. If required for the RH Pitot/AOA probe ([Fig. 401, Sheet 4](#)), install the grounding jumper (7) to the Pitot/AOA probe (4) using the existing washer (14) and screw (13) from the previously installed grounding jumper.
- C. Install Pitot/AOA probe (4) and gasket (6) in structure (1) and align holes.
- D. Attach Pitot/AOA probe (4) to structure (1) with five screws (5).
- E. For the LH Pitot/AOA probe ([Fig. 401, Sheet 3](#)), install the grounding jumper (7) to the aircraft structure by placing hex head screw (11) through hole (12) and securing the grounding jumper with flat washer (10), lock washer (9), and self locking nut (8).
- F. For the RH Pitot/AOA probe ([Fig. 401, Sheet 4](#)), install the grounding jumper (7) to the aircraft structure by placing hex head screw (11) through hole (12) and securing the grounding jumper with flat washer (10), and self locking nut (8).
- G. Do electrical bonding of Pitot/AOA probe (4) to structure (1). Refer to [AMM-20-03-00-051-801 – Electrical Bonding - Maintenance Practices](#). Resistance must be 2.5 milliohms or less.
- H. Do electrical bonding of aft VCS door (12) per instructions in [AMM-21-10-15-041-801 – Aft VCS Door Actuator - Installation](#).
- I. Connect electrical connector (2) to Pitot/AOA probe (4).
- J. Install Auxiliary Heater electrical connector (17) to bracket (16).
- K. Secure electrical connector (17) with jam nut (15). Torque to 35-45 lbf.in (4.0-5.1 Nm)
- L. Connect Pitot/AOA Auxiliary Heater electrical connector (17) to aircraft harness.

CAUTION: DO NOT USE EXCESSIVE TORQUE. TOO MUCH TORQUE CAN DAMAGE AND DEFORM PLUMBING LINES, STRUCTURE, AND FASTENERS.

- M. Connect Pitot tube assembly (3) to Pitot/AOA probe (4) . Torque to 20-30 lbf.in (2.3-3.4 Nm).
- N. Use PRC-Desoto aerodynamic smoothing sealant (PR-2050) to close gaps and seal around Pitot/AOA probes. [AMM-20-08-00-051-801 – Sealants and Adhesives - Maintenance Practices](#).

4. **Job Close-Up**

SUBTASK AMM-34-10-10-041-C-921-002

CAUTION: MAKE SURE ANY PACKING/MATERIALS SUPPLIED WITH THE UNIT ARE REMOVED AND NOT LEFT IN PLACE BETWEEN THE PROBE BODY AND THE AIRCRAFT AFTER INSTALLATION.

- A. If applicable, discard packing block after installation.
- B. Do an inspection/check of the (applicable) Pitot/AOA probe following installation. Refer to [AMM-34-10-00-021-801 – Flight Environment Data - Inspection/Check](#).
- C. Reconnect the electrical connectors on the aft VCS door actuator if removed.
- D. Apply power to the aircraft.
 - (1) Make sure that the Forward and Aft VCS doors have fully closed if opened. Refer to [AMM-21-00-00-071-801 – Air Conditioning - Adjustment/Test](#), Fig. 506 (Sheet 1).
- E. Do adjustment/test of the Pitot/AOA probe(s) following installation. Refer to [AMM-34-10-00-071-801 – Flight Environment Data - Adjustment/Test](#).

CAUTION: DURING THIS TEST, THE HEATERS WILL BE COMMANDED ON BY THE SYSTEM. RH AND LH PITOT/AOA PROBES WILL HEAT UP TO APPROXIMATELY 500°C. HARM TO PERSONNEL OR EQUIPMENT CAN OCCUR IF TOUCHING THE PROBES. DO NOT LEAVE ON FOR EXTENDED TIME. ALLOW 10 MINUTES AFTER TEST FOR PROBES TO COOL.

- F. Do adjustment/test of the Pitot/AOA probe heat. Refer to [AMM-30-30-00-071-C-801 – Pitot and Static Anti-Ice System - Adjustment/Test](#) .
- G. Install access panel that follows as necessary:
 - Install 211 CT - Nose Access Panel. Refer to [AMM-06-50-00-051-801 – Aircraft Access Panels](#).
- H. Remove power from the aircraft.
- I. Remove all tools, equipment and unwanted material from work area.

- J. If all other maintenance is complete, return aircraft to service. Refer to [AMM-20-00-02-051-801 – Return To Service \(After Maintenance\)](#).

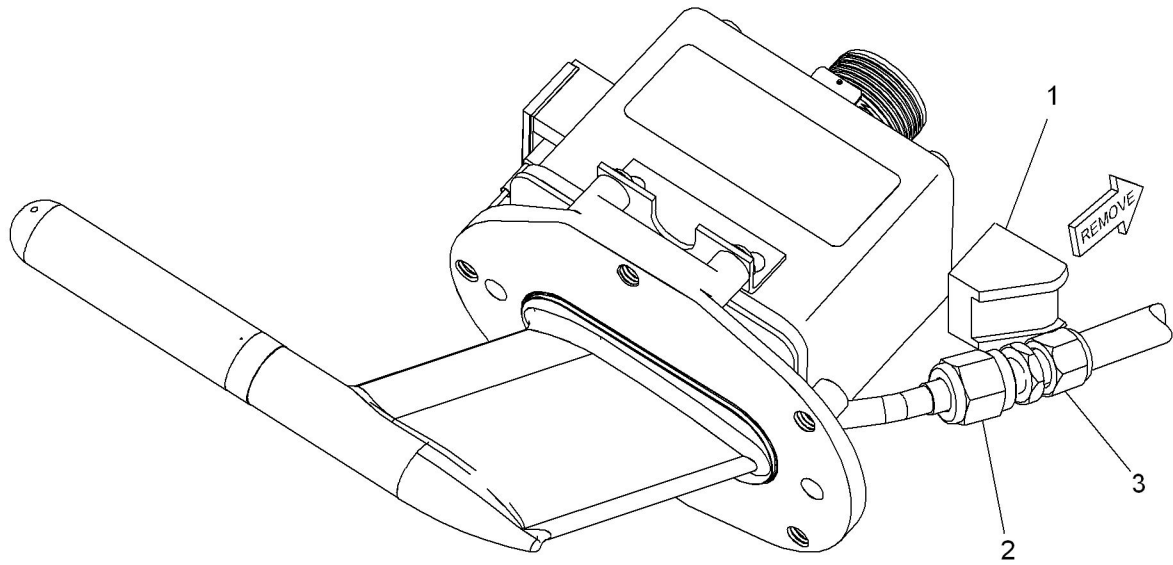
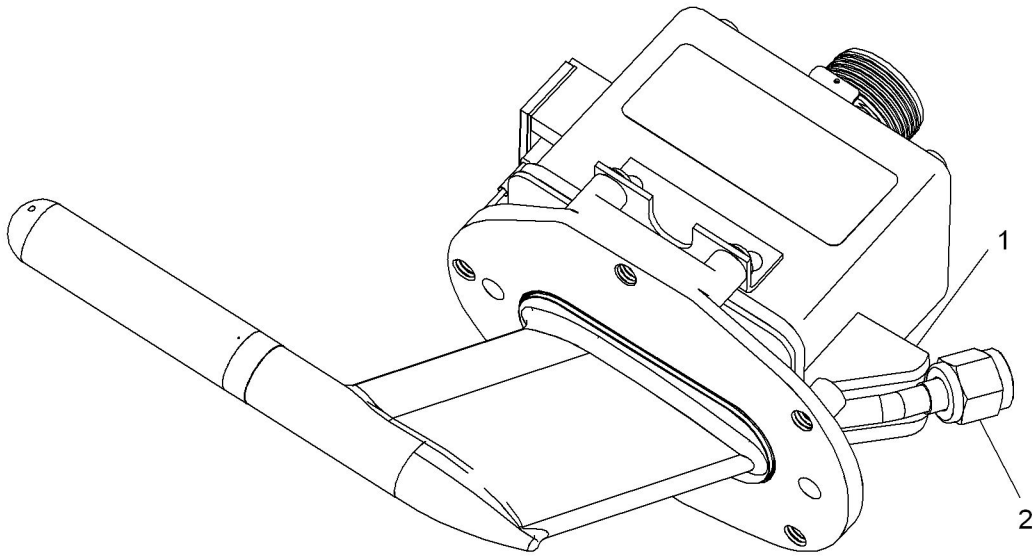

5080979A

Pitot/AOA Probes - Removal/Installation
Figure 401 (Sheet 1 of 5)

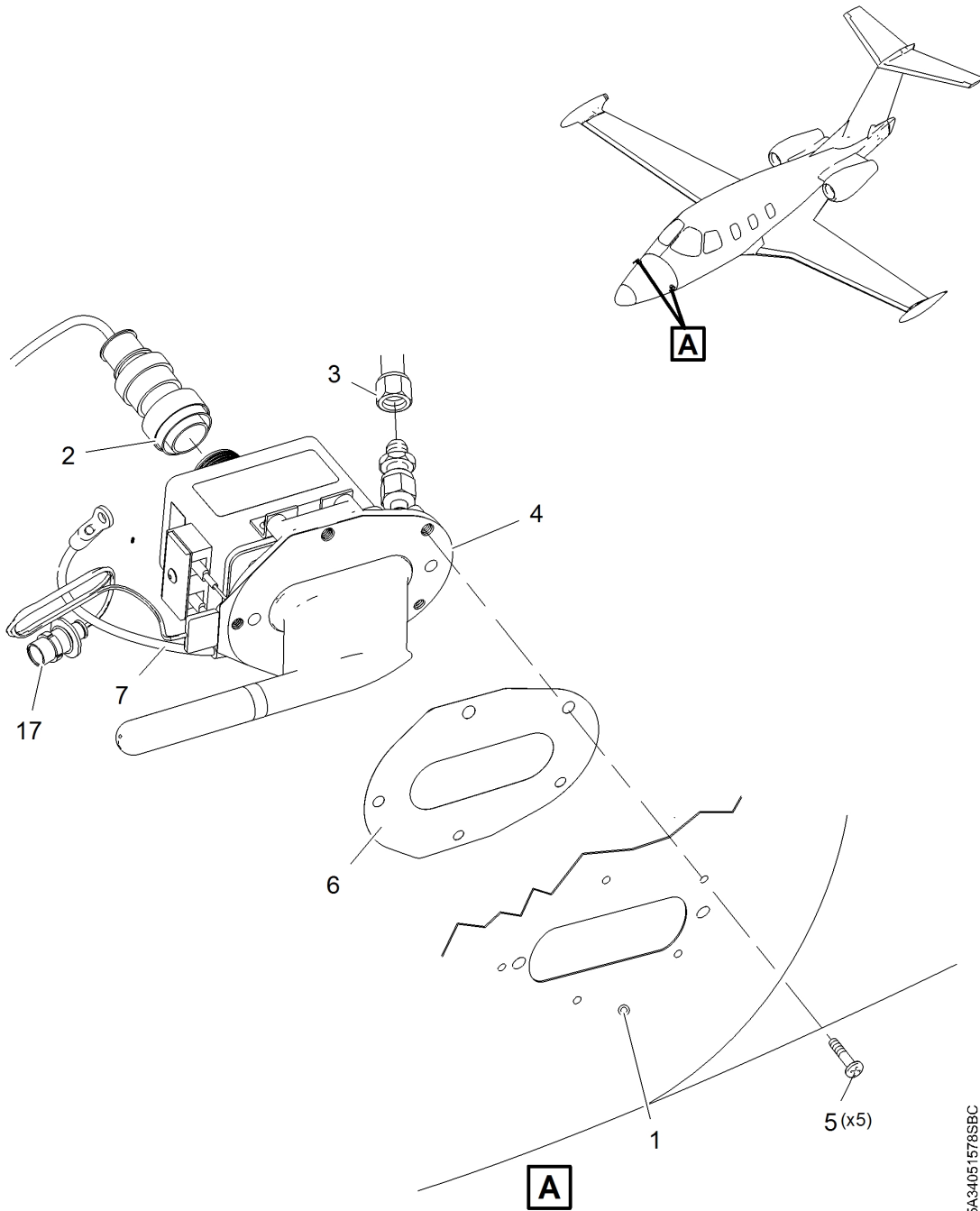

5A34051578SBC

Pitot/AOA Probes - Removal/Installation
Figure 401 (Sheet 2 of 5)

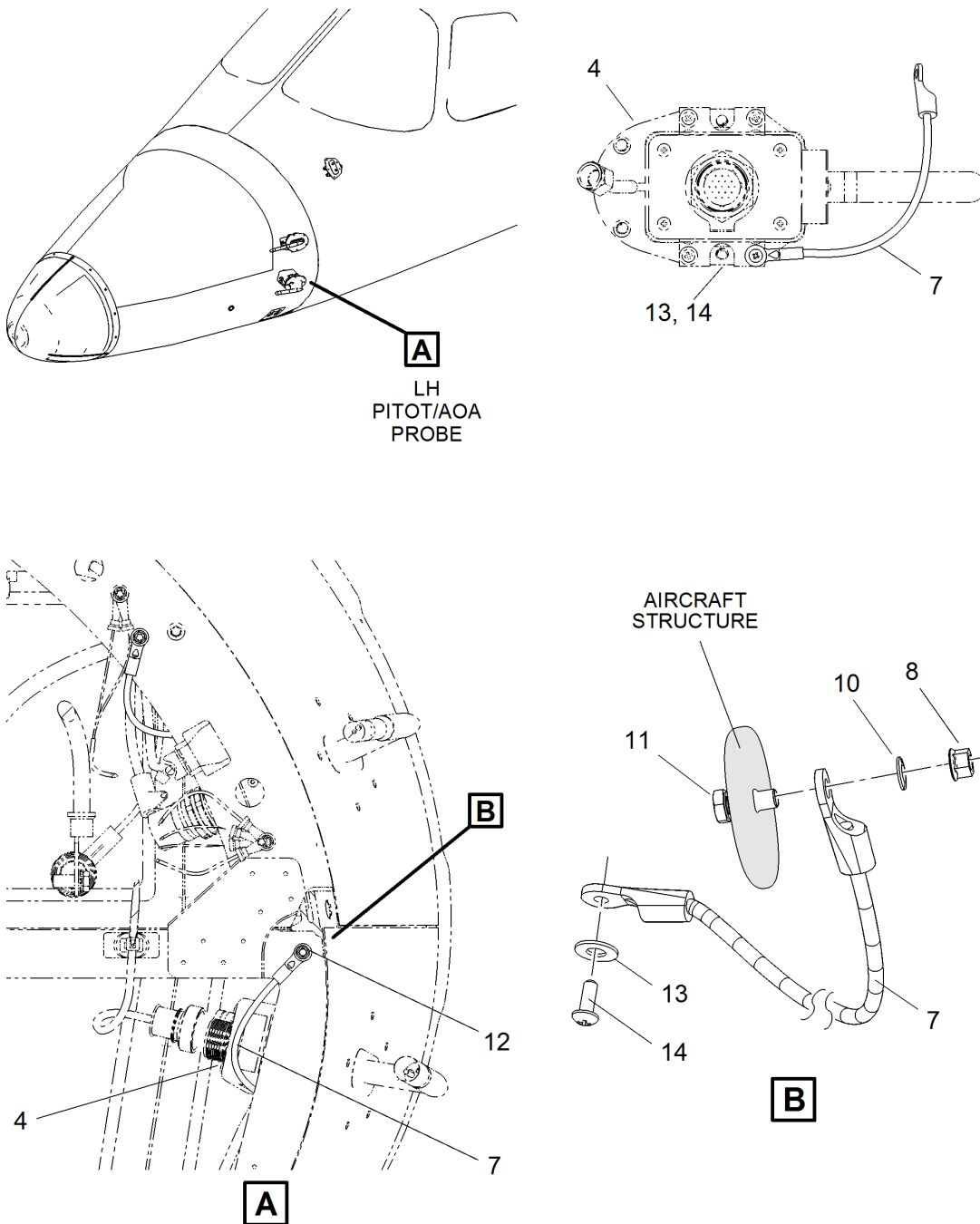

5141820A

Pitot/AOA Probes - Removal/Installation
Figure 401 (Sheet 3 of 5)

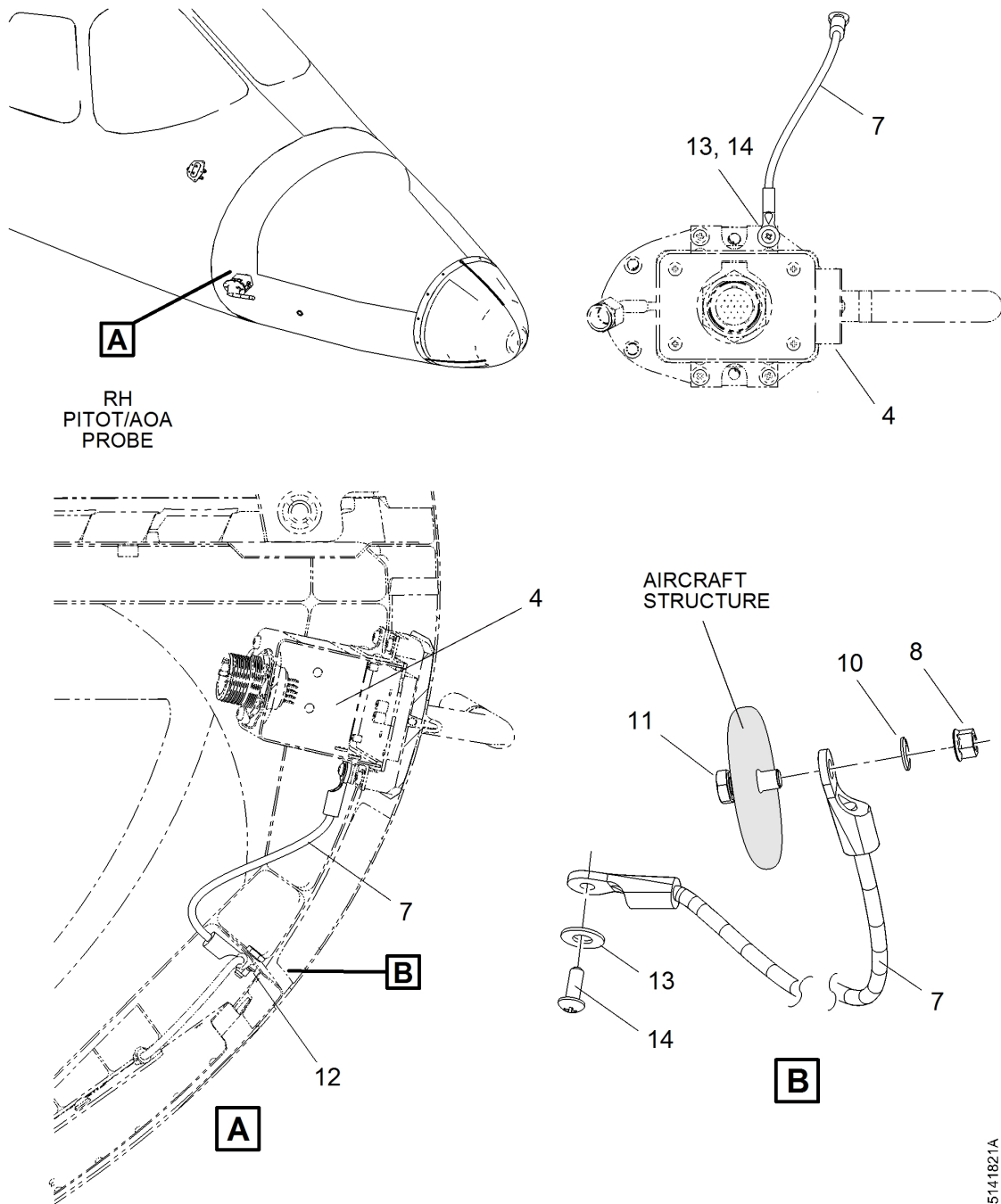

Pitot/AOA Probes - Removal/Installation
Figure 401 (Sheet 4 of 5)

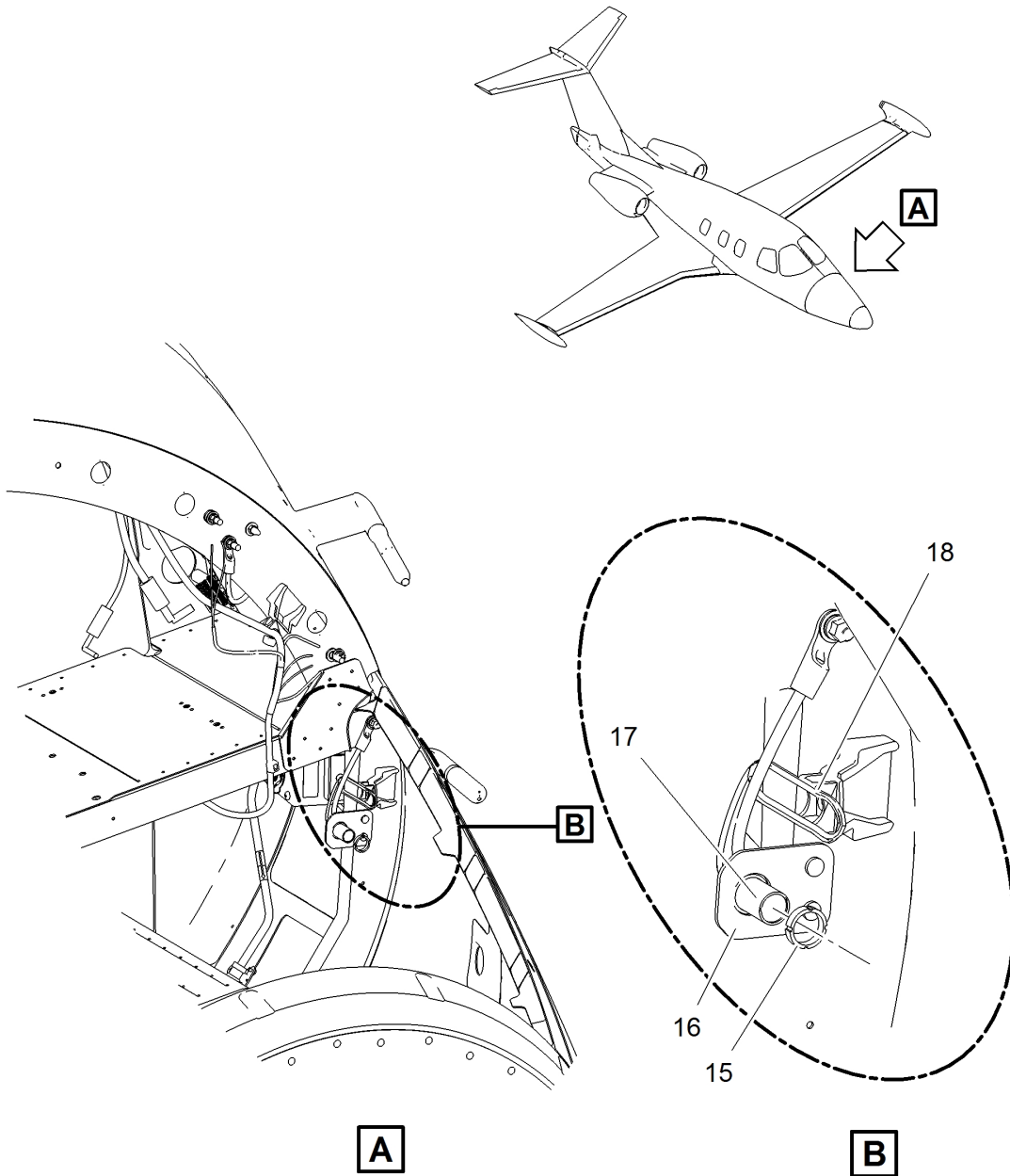

5171943A

Pitot/AOA Probes - Removal/Installation
Figure 401 (Sheet 5 of 5)

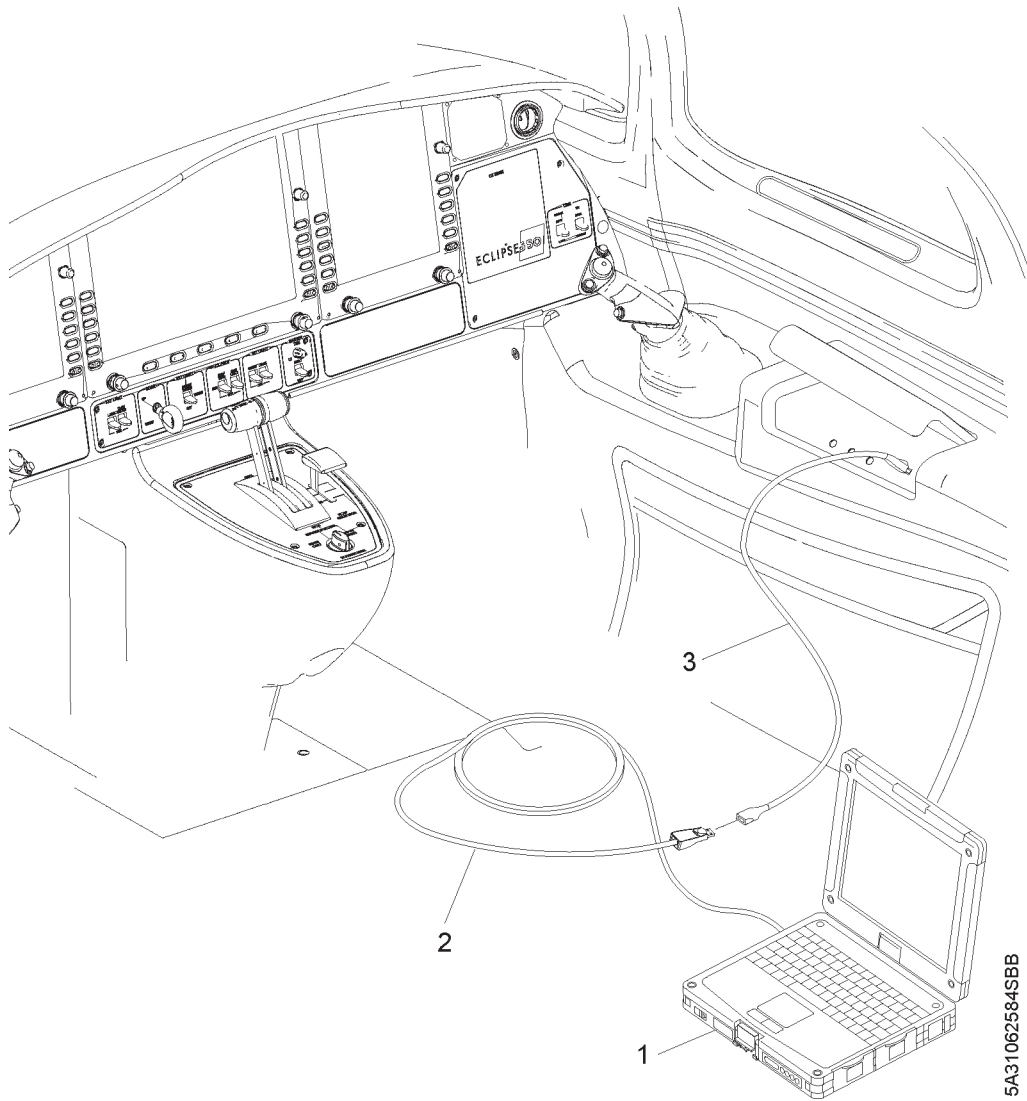

5A3106258-4SBB

Co-pilot's Armrest USB Port - AMC Hookup
Figure 402 (Sheet 1 of 1)

AVIO MAINTENANCE COMPUTER

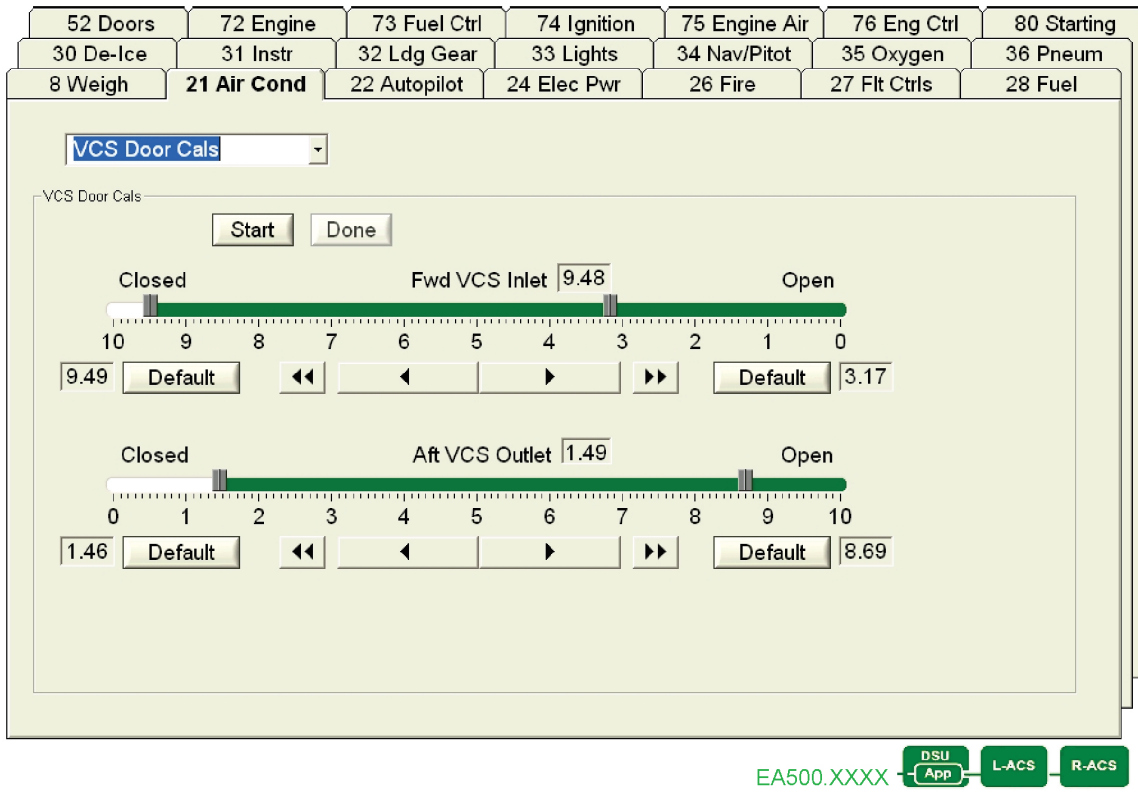

VCS Door Cals Page
Figure 403 (Sheet 1 of 1)

THIS PAGE INTENTIONALLY LEFT BLANK